



This is a digital copy of a book that was preserved for generations on library shelves before it was carefully scanned by Google as part of a project to make the world's books discoverable online.

It has survived long enough for the copyright to expire and the book to enter the public domain. A public domain book is one that was never subject to copyright or whose legal copyright term has expired. Whether a book is in the public domain may vary country to country. Public domain books are our gateways to the past, representing a wealth of history, culture and knowledge that's often difficult to discover.

Marks, notations and other marginalia present in the original volume will appear in this file - a reminder of this book's long journey from the publisher to a library and finally to you.

### **Usage guidelines**

Google is proud to partner with libraries to digitize public domain materials and make them widely accessible. Public domain books belong to the public and we are merely their custodians. Nevertheless, this work is expensive, so in order to keep providing this resource, we have taken steps to prevent abuse by commercial parties, including placing technical restrictions on automated querying.

We also ask that you:

- + *Make non-commercial use of the files* We designed Google Book Search for use by individuals, and we request that you use these files for personal, non-commercial purposes.
- + *Refrain from automated querying* Do not send automated queries of any sort to Google's system: If you are conducting research on machine translation, optical character recognition or other areas where access to a large amount of text is helpful, please contact us. We encourage the use of public domain materials for these purposes and may be able to help.
- + *Maintain attribution* The Google "watermark" you see on each file is essential for informing people about this project and helping them find additional materials through Google Book Search. Please do not remove it.
- + *Keep it legal* Whatever your use, remember that you are responsible for ensuring that what you are doing is legal. Do not assume that just because we believe a book is in the public domain for users in the United States, that the work is also in the public domain for users in other countries. Whether a book is still in copyright varies from country to country, and we can't offer guidance on whether any specific use of any specific book is allowed. Please do not assume that a book's appearance in Google Book Search means it can be used in any manner anywhere in the world. Copyright infringement liability can be quite severe.

### **About Google Book Search**

Google's mission is to organize the world's information and to make it universally accessible and useful. Google Book Search helps readers discover the world's books while helping authors and publishers reach new audiences. You can search through the full text of this book on the web at <http://books.google.com/>

# The automotive manufacturer





TL  
1  
v.59







# The Hub <sup>81466.</sup>

*First Journal of the Vehicle Industry*

Vol. LVIV

NEW YORK, APRIL, 1917

No. 1



ONE Rear Smith  
Wheel will sustain  
Ten Five-Ton Trucks  
loaded to capacity!

Lighter Than Wood—Many Times Stronger

Smith Wheels Guaranteed  
DURING LIFE OF TRUCK  
on which originally placed

Tire Mileage Increased—Gasoline Mileage Increased  
Truck Life Increased

**SMITH WHEEL** INC.  
SYRACUSE, N.Y., U.S.A.

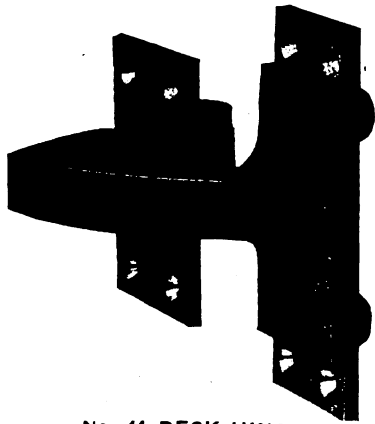

No. 44 DECK-HINGE  
For Roadsters and Closed Bodies

Please note the extra body plate. Also the dowel which centers the machine screws, facilitating assembly of hinge to the body.

Another evidence of our system of improvements and suggestions on hardware articles.

We will manufacture high class hardware at less cost to you and give you prompt service.

Our No. 39 Concealed Hinge should be used on your touring bodies.



Detroit, U. S. A.



## SEAMLESS TUBING STEEL—BRASS—COPPER

Send Us Your Specifications  
for Rush Requirements

MURCOTT-DUDEN CO., Inc.

253 Broadway

New York



# steel stampings

*especially for*  
**COMMERCIAL TRUCKS**

The Pressed Steel Co. of N. Y.  
Woolworth Bldg.

## The Laidlaw Company Inc.

New York City

.....

**Automobile  
Fabrics**

.....

**A Fabric for  
Every Purpose  
For Closed, Open or  
Convertible Bodies**



# Bliss Power Presses—Standard for 58 Years

When you buy a press, keep this one fact in mind: You are buying for now and for the future.

Machinery is the last thing on which to try to save money. No press can be too good for you—too strong or too serviceable.



## Buy Bliss Presses



And make an investment that pays dividends in money saved on power consumption, on repairs and money saved by increased efficiency. You are assured of absolutely steady, reliable service.

There is a Bliss Press to successfully meet every sheet metal working requirement. Write today, advising your requirements.

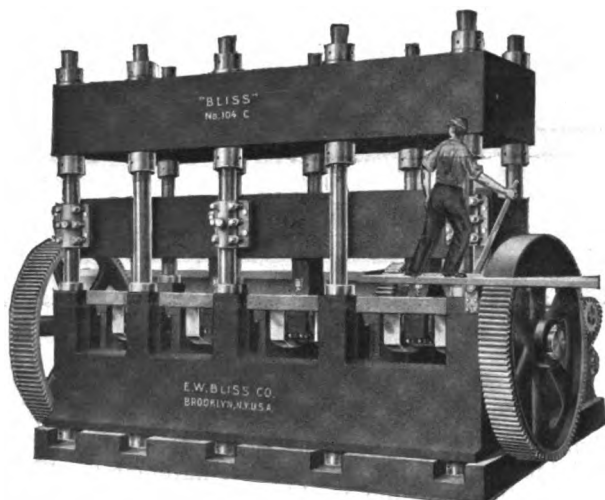

"Bliss" Bottom Slide Multiple-Crank Press No. 104-C. Weight, 140,000 lbs.

Built in a large number of sizes "Bliss" Bottom Slide Multiple Crank Presses are specially designed for forming automobile side frames and cross-rails, steel-car parts, fence posts, channels, angles and miscellaneous heavy forming work of like character.

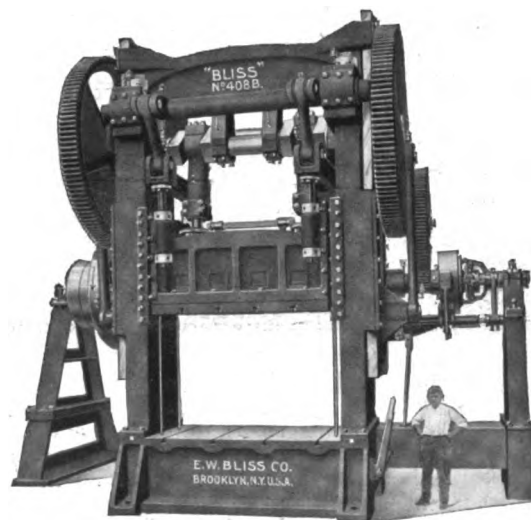

"Bliss" No. 408-B Double-Crank Toggle Drawing Press. Weight, 125,000 lbs.

Built in many sizes "Bliss" Double-Crank Toggle-Drawing Presses are adapted for drawing and forming from heavy stock irregular and oblong shaped articles of large area such as automobile radiators, fenders, running boards, engine pans, gear covers, doors, etc.

**"THERE IS A BLISS PRESS FOR EVERY REQUIREMENT"**

**E. W. BLISS CO., 38 Adams St., Brooklyn, N. Y.**

Chicago Office: Peoples Gas Building

Detroit Office: Dime Bank Building

Cleveland Office: Union Bank Building

Offices in Europe: 100 Boulevard Victor-Hugo, St. Ouen, Paris; Pocock St., Blackfriars Road, London, S. E.

Please mention "The Hub" when you write

# Keratol LEATHER SKINS

For the car where leather has always been used



## PRICE

*Within Reason*

## QUALITY

*Maintained*

**W<sup>m</sup> L. BARRELL Co.**      **8 THOMAS ST.  
NEW YORK**



**MOTOR QUALITY  
FOR UPHOLSTERY**



**RAYNTITE  
FOR AUTO TOPS**

**P**REVALENT leather market conditions compel the adoption of a leather substitute for upholstering automobiles and carriages. FABRIKOID, Motor Quality, has established itself for upholstering requirements. It is pliant, strong and stands a greater strain than so-called "genuine leather" without tearing, and is positively waterproof. FABRIKOID, Motor Quality, is continuously advertised in popular magazines and auto publications. Prospective owners of upholstered vehicles know the advantages of FABRIKOID, Motor Quality, upholstery over the so-called "genuine leather." Adopt FABRIKOID, Motor Quality, and solve the vehicle upholstery problem finally and satisfactorily.

**T**OP materials of light weight structure and guaranteed to be weatherproof are what are secured by the adoption of RAYNTITE.

Light weight tops meet the demands of the feminine autoist now entering the automobile field. Lightness of top combined with absolute protection and fine appearance makes a strong and convincing appeal to prospective purchasers.

Top your cars with RAYNTITE—the guaranteed, service-tested, light-weight topping material extensively advertised and demanded by those who know RAYNTITE'S merits. Top-makers should write at once for details of our co-operative advertising plans.

*Samples of MOTOR QUALITY and RAYNTITE Showing Various Colors,  
Grains and Finishes Sent Promptly on Request*

**Du Pont Fabrikoid Co.**

Wilmington, Del.      Toronto, Ont.

FACTORIES: Newburgh, N. Y.  
Elizabeth, N. J.  
Fairfield, Conn.  
Toronto

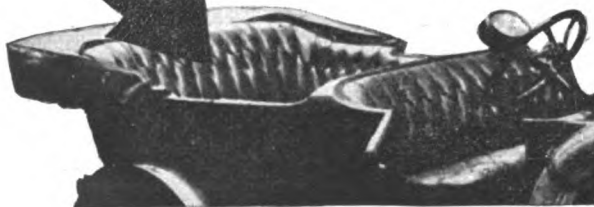

Please mention "The Hub" when you write.

# MERITAS LEATHER CLOTH

## The Leading Leather Cloth for Carriage Builders

We were the first manufacturers to give the trade something superior to old style enameled goods.

Today we serve carriage and auto builders with the most comprehensive line of leather substitutes on the market.

Meritas Leather Cloth has textile strength plus surface durability because only the highest grade oils and colors are used.

Whatever weight, finish, grain or color you require in a leather substitute we can supply it.

We are the largest manufacturers of this class of goods and we can deliver the quality you want.

To avoid disappointment always look on the back of the goods for the Meritas Leather Cloth trademark.

**The Standard Oil Cloth Company**

INCORPORATED

320 Broadway

New York

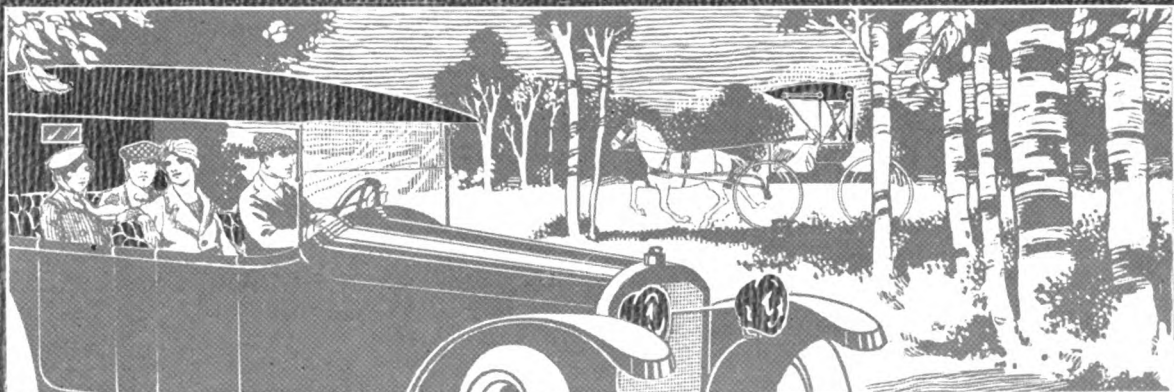

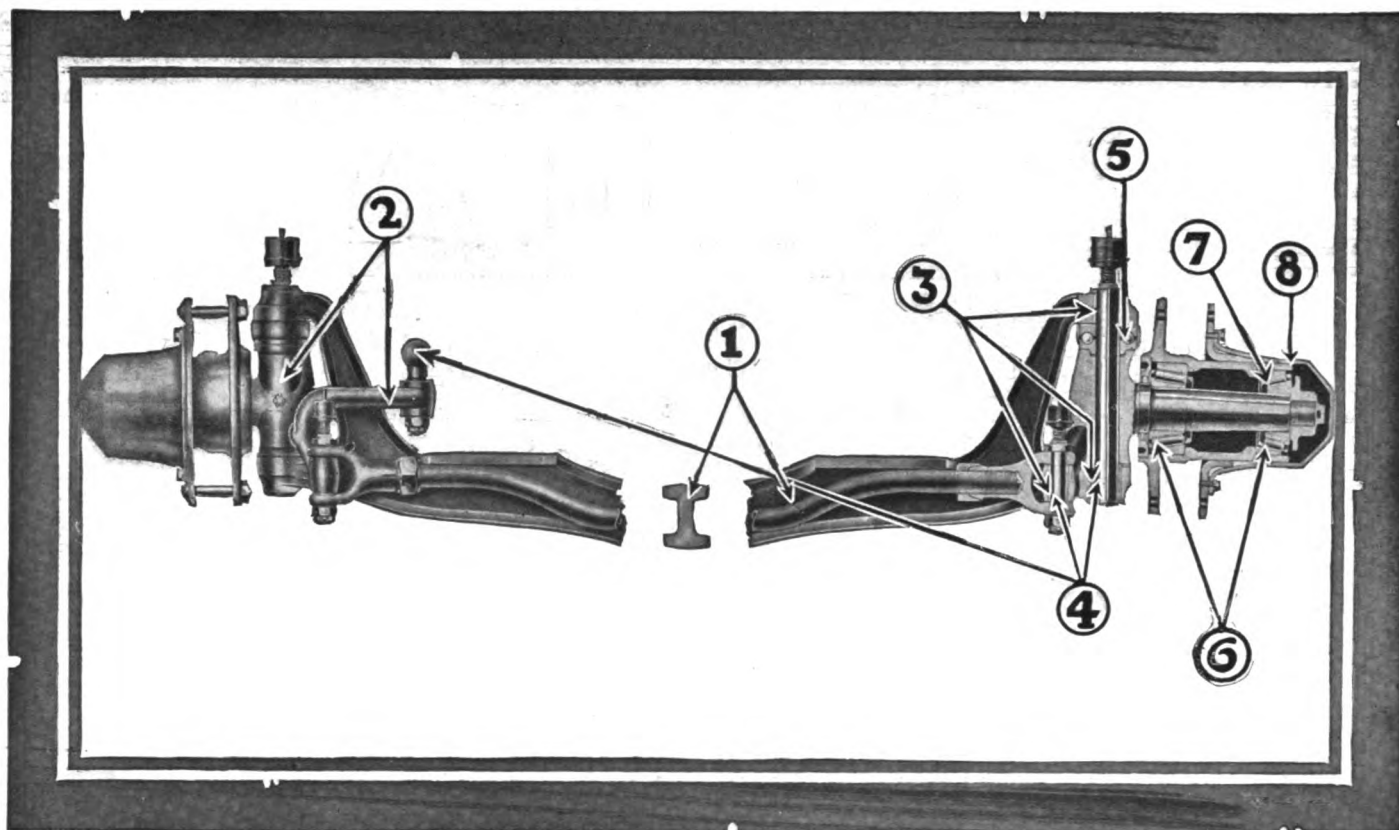

## Why **SHELDON** Front Axles are Better Axles —

**1** Heat-treated axle bed—drop forged in one piece—I-beam section—strong, yet light.

**2** Steering levers and knuckles drop forged— $3\frac{1}{2}\%$  nickel steel—properly heat-treated.

**3** All wearing surfaces protected by steel bushings.

**4** Clevis Pins, Ball Pins and Pivot Bolts hardened and ground to size—extra large wearing surfaces.

**5** Ball thrust bearings—make steering easy.

**6** International series wheel bearings—two row ball-bearings, straight roller or taper roller-bearings, all interchangeable—single row annular ball-bearings can be used by employing spacer.

**7** Extra large outer bearing—increases life of bearings and spindles—reduces upkeep cost.

**8** Bolted on hub caps—outer bearing protected from injury in case of collision.

**Sheldon Axle and Spring Company**  
Wilkes-Barre, Pennsylvania

Please mention "The Hub" when you write

Digitized by Google



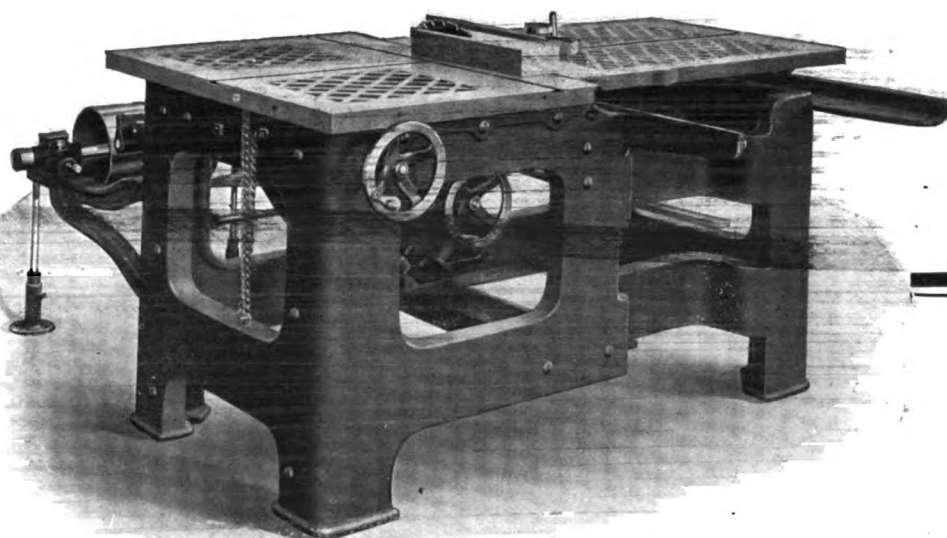

## PETTINGELL

### Extra Large Bevel and Mitre Saw Table

Heavy work requires a heavy machine. We have built this new machine *massive* and *heavy* and *rigid* to withstand the strain of modern Mill work. It *does* it—does even more—combines all the best ideas of our small Bevel and Mitre Saw with many new improvements, and practical features found *only on this machine*.

Frame work and entire construction are built to eliminate warping or twisting of tables or parts. This permits you to do *perfect duplicate work*. You can saw any bevel, mitre, angle or two angles *at once* and the work will be *accurate* to a dot. It saves time and labor, too.

### Saw Can Be Raised or Lowered at Any Angle Up to 45 Degrees Without Stopping the Machine

The work is always level, it cannot bear down on either saws or gauges. Left-hand table can be quickly moved and adjusted as work requires, and the right-hand table can be easily moved to allow Dado heads in place of saw. The table runs very easily, being provided with special rolls and tracks.

It's the best Bevel and Mitre Saw Table in the world—installed in the largest and best factories in Detroit and middle west.

Sold on a guarantee of satisfaction.

A trial is all we ask—the machines do the rest.

**Over 400 factories are now using our machines.**

We will help you plan and install complete machinery equipment for any kind, style, quantity or output of work you need.

# PETTINGELL MACHINE CO.

AMESBURY, MASSACHUSETTS

# Heredity and Environment

GRAND PRIZE

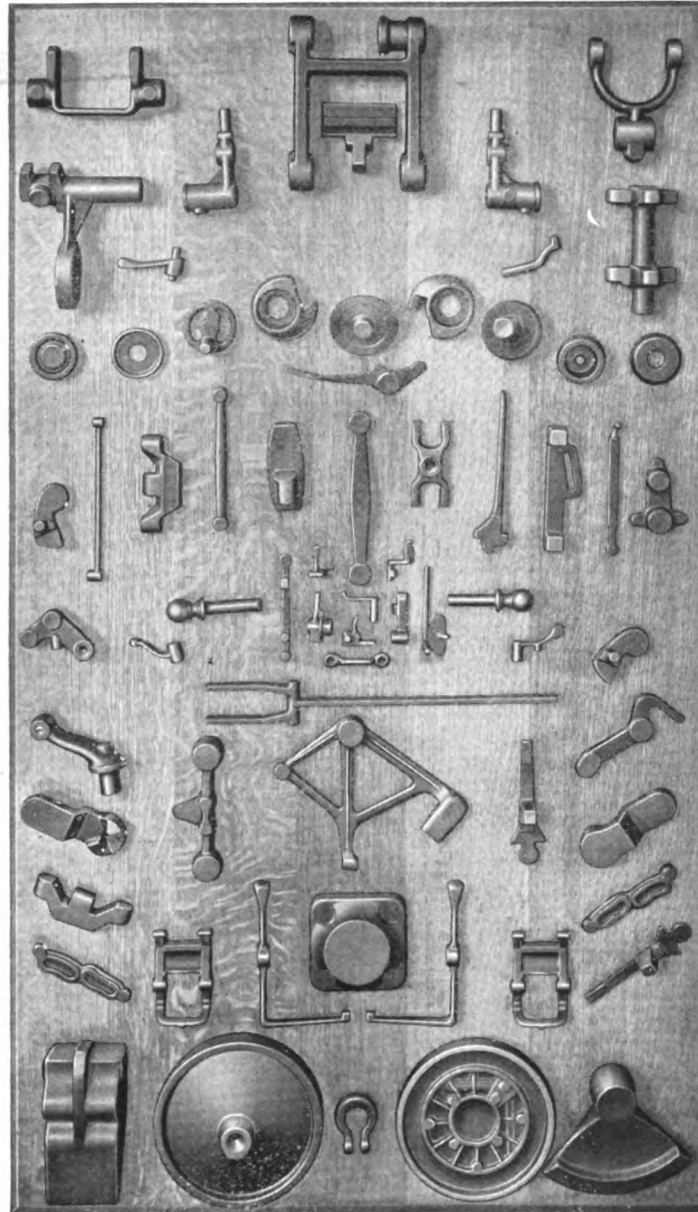

DROP-FORGINGS

determine the life and accomplishment of drop-forgings as surely as they affect the nature and achievements of men.

Those that will endure cannot, by superficial inspection, be differentiated from those that will fail.

Correct design, uniform size, smooth surface and machining characteristics, important as they are to your progress, afford scant clue to drop-forged character.

What elemental ingredients contributed to their make-up; in what proportions were they combined, and how united in the molten mass; how poured, cooled and cropped; how selected, tested and rolled; how comprehensively analyzed; how heated, forged and trimmed; how cooled, tempered and hardened; how straightened, inspected and tested?

These are the deciding factors in drop-forging endurance and they are known to but few specialists, equipped with modern facilities, adequate to determine and control them.



Please mention "The Hub" when you write

# The Hub

Vol. LVIV

NEW YORK, APRIL, 1917

No. 1

Published Monthly by

## THE TRADE NEWS PUBLISHING CO. OF N. Y.

PAUL MORSE RICHARDS, *President* G. A. TANNER, *Secretary and Treasurer*  
EDISON BUILDING, COR. ELM AND DUANE STS., NEW YORK

THE HUB, a monthly authoritative journal on all subjects pertaining to the vehicle industry from its engineering and construction viewpoints. It publishes information of live interest to manufacturers of motor vehicles, trallers, carriages, wagons, the accessory trades, repair shops and garages.

Subscription price for the United States, Mexico, Cuba, Porto Rico, Guam, the Philippines, and the Hawaiian Islands, \$2.00; Canada, \$2.50; payable strictly in advance. Single copies, 25 cents. Remittances at risk of subscriber, unless by registered letter, or by draft, check, express or post-office order, payable to the order of THE TRADE NEWS PUBLISHING CO.

For advertising rates apply to the publishers. Advertisements must be acceptable to publishers. Copy for new advertisements must be received by the 25th of the preceding month. All communications must be accompanied by the full name and address of writer.

Entered in the New York Post Office as Second-class Matter

### Food Situation Demands Attention

The closing months of the crop year finds this country with a smaller stock of all kinds of food than at any time in many years. The government report of grain stocks on March 1 shows that at best there will be no carry-over of wheat. There is not enough in the country to allow of exports to July 1 equalling those of the corresponding period last year, without trenching upon the home requirements for bread and seed. Stocks are unusually light in all European countries, and on account of the scarcity of shipping, ocean charges are much less from America than from Australia or India, which are the only other countries which can supply much wheat between now and July. Argentina has now put an embargo upon exports of wheat and flour.

There is reason to believe that much can be done which will show results in this year's crop, if the business men of all localities will rise immediately to the occasion. Foreign governments are buying farm tractors in this country in large numbers in order to make good the shortage of labor. A call for enlistments in this country will probably draw hundreds of thousands of young men from the farms, and unless their loss is made good by implements and the labor of women it will appear in a reduction of the crops. The question of seed supply is important. The threatened reduction of potato acreage in New York state is because seed is not to be had locally, the price is very high, and unless there is an organized effort to supply seed the planting will be curtailed. Something needs to be done to overcome inertia and make it convenient to do the usual planting and increase it.

There is an important amount of labor in all towns in the agricultural districts which can be loaned to the farmers at the critical periods. This would be systematically

done if it were a life and death question in each locality—and this year there is a world emergency which calls for just such organized effort.

The Carnegie Steel Co. has rented 200 acres of land near its Youngstown works which it will subdivide and offer to employes for their cultivation. The company will plow the land and supply fertilizer. Numerous similar announcements are made, indicating that the movement may become widespread, and it is highly desirable that this shall be the case. The employer is interested because the whole industrial situation may be disorganized by high prices for food, and the wage earners are interested because unless sufficient food supplies are grown no possible wage advances can provide enough for all.

### War Preparations

The Council of Defense has been busy for many months planning for the organization of the country's industries to support the army and navy in the event of war, and the resources placed at its command are very great. The immediate requirements of the government will not in themselves amount to a very large percentage of the aggregate capacity, but coming at a time when capacity is already engaged for months ahead the effect is to make the situation more difficult for private buyers. This is particularly the case in the steel industry and with special reference to ship plates. There is the most urgent demand for plates for merchant ships, and the mills are sold up on their output far into 1918, but the government will have the first call if it wants it.

The whole industrial situation has tightened up, for besides the capacity taken up by government orders the imminence of government orders has given a spur to other business. As is always the case when new demands develop there is a scramble all around to cover future requirements. It is evident that the productive capacity of this country will be used to the limit throughout this year, and until the war requirements are done with. In view of the national emergency it is time to sound a warning for patriotic reasons against all unnecessary undertakings or expenditures which will divert labor or money from the most important uses. Work which can go over to another year should be postponed in the common interest. The war needs should have the first call on the industries. For economic reasons also, this is no time for capital investments which can be made later.

### Ohio Light Regulations

The Ohio General Assembly has enacted a law compelling all vehicles with the exception of hay and straw wagons, to carry lights visible to the front and rear.



## Motor Cars in South America

That the motor car is finding its way into the remote sections of South America, and that the great southern continent will eventually offer an immense territory for the automobile manufacturer to take into consideration and to cultivate, is brought out in an article by William R. Reed, in the Bulletin of the Pan-American Union, Washington, D. C. Even in those countries where good roads are scarce the automobile is becoming a necessity for industrial purposes, for in many places it is beginning to demonstrate its value in the transportation of freight and passengers where railroads are impracticable or too expensive to build. Mr. Reed writes:

In the barren nitrate section of Chile, where the cart and mule have long done faithful service, one finds today a number of automobiles. During a recent journey through the nitrate fields several machines were placed at the writer's disposal, and they did excellent service over some of the most trying trails to be encountered in any country. Furthermore, it was learned that eight motor trucks are to be given a trial in the handling of nitrate. The two-mule team and cart in general use at present cost about \$700. Small locomotives, costing several thousand dollars, may eventually be replaced by the motor truck if it proves its practical utility. The truck, costing from \$2,000 to \$3,000, may prove itself more economical than the old system; the clearing and building of a cheap road for the truck will certainly be less expensive than the laying of railway tracks for the locomotives and dump cars. At any rate, the experiment is well worth watching by those interested in the sale of commercial cars; for should the 140 companies operating in Chilean nitrate eventually adopt the auto truck the demand will gradually grow to thousands of machines.

A few months ago, while the writer was in Paraguay, the first motor truck ever seen in that country arrived in Asuncion. A considerable number of pleasure cars, especially those of cheaper grades, are in use in the Paraguayan capital; but the arrival of the monster truck created a new interest, and hundreds of citizens watched the American agent demonstrate the possibilities of his machine. Even the President of the Republic and several members of his cabinet were willing to undergo the ordeal of riding over one of the roughest sections of highway that could be selected for the trials. The truck proved a wonder worker, and people and newspapers made many favorable comments. Its advent in Asuncion revived a movement previously started, to place several motor trucks in service between interior districts and the larger towns, where the only means of transportation today consist of cart and pack animals.

Bolivia, one of the world's most diversified countries topographically, has been using the commercial automobile for several years to great advantage. Railways were not being built with the activity that the country's trade demanded, and trucks were introduced on a regular run from Potosi to Sucre, a distance of 150 miles, where highways are far from good. This was an experiment in freight and passenger service; and the cars long ago demonstrated their practicability. Since the advent of the truck in Bolivia the roads have received more attention than formerly; the pleasure car has become a necessity, and their number has increased, especially in La Paz.

Peru, as everyone knows, is not a land with many miles of automobile roads. There are, however, in Lima, the

capital, over 300 machines, many of which are used as taxicabs. In Columbia the Department of Public Works has made plans, backed by government appropriations, for constructing highways suitable for automobiles.

The greatest natural field for the automobile, however, in South America is to be found in Argentina, Brazil, and Uruguay, and in each of these countries improved highways are being extended and motor vehicles multiplying rapidly. In 1913 Argentina alone imported 5,115 automobiles.

## Contraction and Expansion of Metals

In welding or preparing a bar of iron to fit a certain measurement, account must be taken of contraction and expansion, but the great majority of practical smiths allow guess work rather than actual fractions to guide them. And should the expansion or contraction be less or more than what was at first thought, then a little further shrinking or drawing out of the bar is followed and the desired limit thereby obtained. Now smiths are in the habit of allowing about one-eighth of an inch to the foot for contraction, but how far off they may be in their judgment is told first by the size of bar on which they are working, and second, by the amount of heat or temperature that is given it. Now, temperature is something that smiths think little of. At least, those of the practical, every-day kind, and only those who have been taught in schools where chemistry has been the basis of their primary education have much knowledge of heat density, or temperature, as it is otherwise called.

In the setting of a tire, is this subject of expansion or contraction always an issue and of decided importance? In order to give the proper dish to the wheel, the condition of the body of wheel being first considered, is followed by an absolute certainty in the amount of contraction provided for by the tire. A 2 x 1/2 tire heated to a temperature of about 400 degrees, which is a stage just approaching the dark red; such a tire heated to the degree mentioned, should be given 3/8 to 1/2 in. for contraction when cooled, and as the scale is descended and as the light buggy tire is reached, the wheel and heat degree being also considered, the allowance grows correspondingly less.

Contraction has an immense influence on such an object as a wheel. If the tire is heated very hot as sometimes happens and the right limit for contraction has not been figured by the smith, the wheel is likely to be either too much dished or is worse off after the tire has been set than before it was removed. Tire setting is therefore of more importance than most men are given to believe, but due to the extremely common practice which all smiths indulge in of allowing just so much and no more to the tire for contraction, no such thing as the chemistry of metal and heat degree is thought of.

In the beginning, however, if this subject was properly understood and respected in practice, their might not be so many wobbly wheels and far more wheels of the solid, indissoluble kind, made so purely through the intelligence of the smith in adjusting the scale of contraction and expansion in the proper degree.—Horseshoers' Journal.

## Perlman Sues Firestone

The Perlman Rim Corp. has brought suit against the Firestone Tire & Rubber Co., alleging infringement of its demountable rim patent No. 1,052,270.

## Description of Fashion Plates

### Simplex Six Passenger Touring Car

The illustration top of page 12 is that of a Simplex six-passenger touring car with special Holbrook body. This is of the so-called torpedo type, with polished aluminum bonnet and maroon leather victoria top with a cloth head lining to match the trimming in the tonneau.

There is a storm curtain from the top to the windshield, made of heavy maroon leather, with the customary side curtains. There is an envelope for the top when down.

The tonneau is trimmed in gray cloth. Figured silk slip covers protect the cloth trimming of the tonneau. The two extra seats fold flush in a cabinet at the back of the driving seat when not in use and are concealed by roll curtains. The mahogany cabinet at the back of the front seats has a compartment at the top for canes and umbrellas and one at the center between the extra seats for smaller articles. The front seat, divided at the shoulder, is trimmed with maroon leather; there are two cushions.

The car is equipped with special wire wheels; 35 x 5 tires all around. Spare wheels are carried at the rear. The body is painted pearl gray. The chassis, wheels and underside of mudguards are painted maroon. The top part of the guards are pearl gray. A suit case trunk is placed on the running board.

### Small Enclosed Drive Simplex

The small enclosed type of car illustrated in center of page 12 is fit for the man who likes to drive, with or without his chauffeur. With the front partition windows down intercourse is unrestrained; with the windows raised the rear compartment is as confidential as that of any limousine. This style of body is lighter than any other wholly enclosed body and is perhaps capable of so-called "smarter" effects. One partition window, with two panes, is raised or lowered by fabric lifters, as are the rear windows. The glasses in the back doors have mechanical lifters and all four doors have safety locks.

There is an extra seat on the left side of the partition, with lazy-back, to ride crosswise; a spring-up seat on the right side of partition, with aisle between, adds another passenger who rides backward. The rear seat holds three. The roof is leather, colored to match the painting. An eight-day watch is mounted on the partition. The windows are fitted with green silk curtains, with automatic rollers. The interior is trimmed with green broadcloth. All inside mountings and fittings are also in green instead of nickel. An electric telephone, with spring actuated cord, communicates with the driver through a loud-speaking horn at his ear. The dome light in the roof over the rear seat has a switch on the cowl and a push button in the wall of the rear compartment. The driving compartment has a single undivided seat, with two cushions of long grain, dull finish leather to match interior trimmings. Tool drawers and storage space with locks, are fitted under the seat, and special brackets for jack and handles are found under the cowl, which has a mechanical ventilator.

It is painted a medium green. The mouldings and mudguards and uppers of the body are black; white striping on chassis, wheels and body. Spare tires are carried at the rear.

### Touring Landauette

The smart looking touring landauette body illustrated on bottom of page 12 was built by Stone (Chicago) and

is mounted on a Simplex chassis (Crane model). This car is often used for touring and combines speed, reliability and comfort to a remarkable degree. Dull gray paint is used for the major portion of the body and wheels. The fenders, chassis, mouldings and leather top are black. The spare tires are carried one in each front fender in covers to match the body color. The radiator and front springs are protected by leather splash apron. A trunk rack is mounted in the rear. Driver's storm top and side curtains button on the windshield and partition. The top and the pillars fold up and the windows disappear, transforming it into a complete open car. One spare seat with nickel arm rests folds against the partition behind a hinged cloth-covered robe rail, while another smaller seat folds into the floor. The toilet case with eight-day clock and usual articles is finished in black. The carpet matches the upholstery. Two two-bulb lights are placed in the rear portion of the top, operated by a switch on the right arm rest, or by the driver from the instrument board. All windows have mechanical regulators. Foot and pillow cushions are among the comforts. The driver's seat is in gray leather, dull finish. The telephone ear piece has been placed under the cowl, which has a mechanical ventilator. A spot light has been put on the right hand side of the windshield. There is a locked tool drawer under the driver's seat. Part of the storage space under this seat has been arranged with an opening into the rear compartment to hold miscellaneous articles.

### Locomobile Touring Car

The body of the touring car illustrated at top of page 13 was built by the Holbrook Co., of New York, and is mounted on a Locomobile body. This car was exhibited at the salon in Hotel Astor, New York, in January. It is painted in gray, extra light, and striped in combination gold and deeper gray. The upholstery is in dark blue hand buffed leather.

## Vehicle Builders' Meeting

A special meeting of the Carriage Builders' National Association was held at the Hotel Gibson, Cincinnati, O., March 28, for further discussion of the conditions which are preventing manufacturers from obtaining supplies of materials. This includes the freight congestion, although some improvement was noted, compared with the conditions as reported when the special meeting of February 27 was held.

The situation is still serious, and manufacturers are handicapped in their efforts to produce vehicles to fill orders already obtained. More relief, however, is expected within a short time. The manufacturers are anticipating an increased demand for buggies as compared with last year. The cost of production has been materially increased, of course, and an advance in prices probably will be made.

The association will hold another special meeting at the Hotel La Salle, Chicago, June 27.

## Prisoners to Make Auto Bodies

Prisoners in the state prison in Maine have been set at work on a contract for 200 automobile bodies. In the past prison inmates have been taught the carriage making trade, but there has been so little demand of late for this product that the warden decided to turn the carriage making crew into motor car body builders.

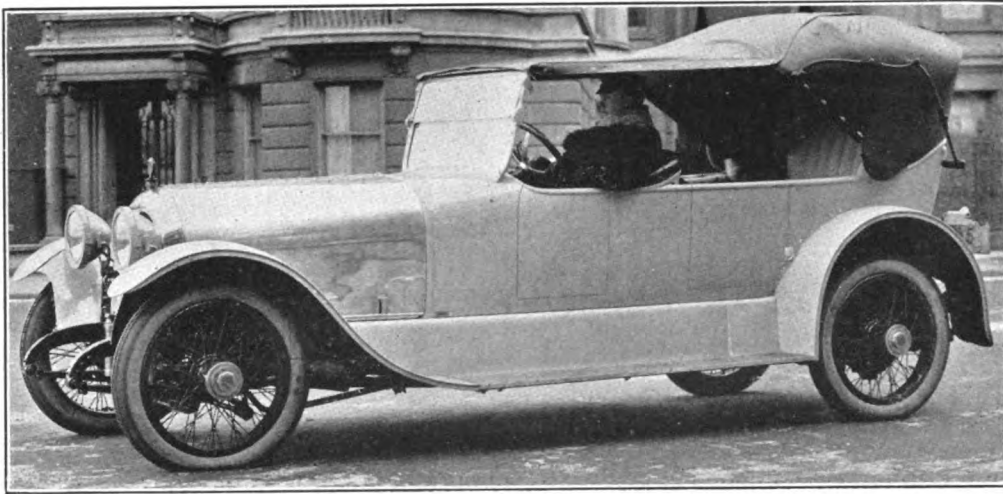

**SIX-PASSENGER TOURING CAR**  
Holbrook Body on Simplex-Crane Chassis

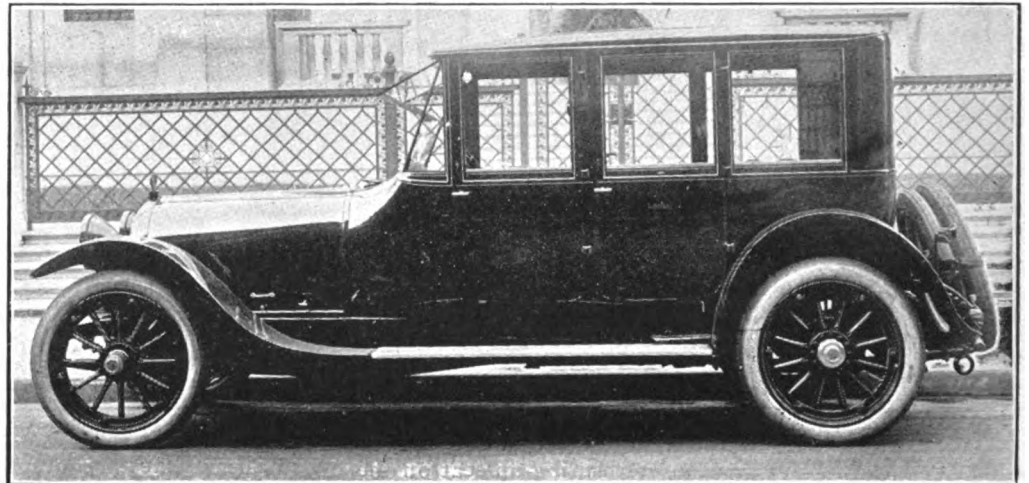

**SMALL ENCLOSED DRIVE**  
Built by Simplex Automobile Co., New York City

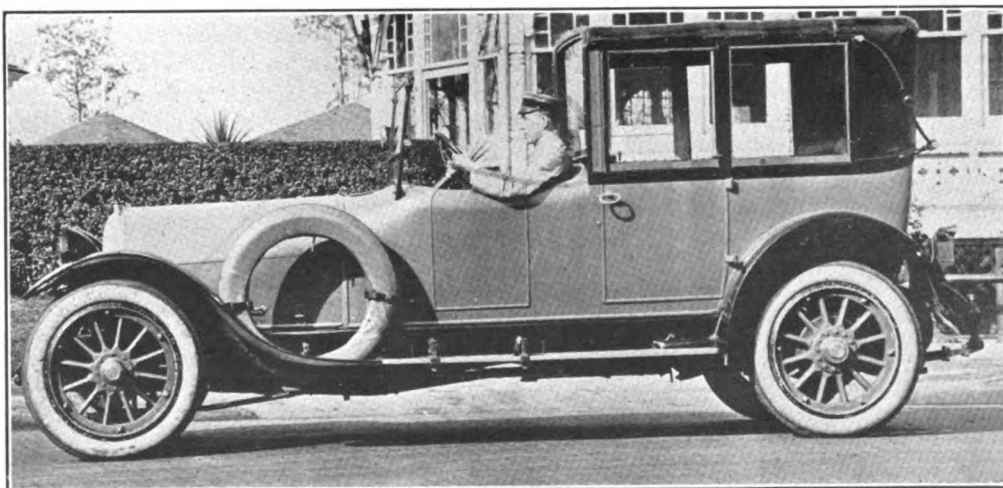

**TOURING LANDAULETTE**  
Stone (Chicago) Body on Simplex-Crane Chassis

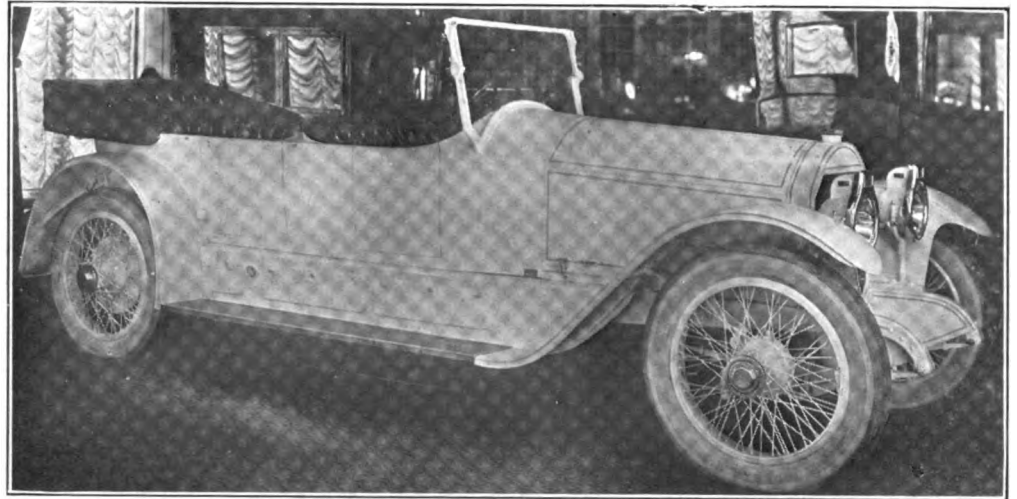

**LOCOMOBILE TOURING CAR**  
Body by Holbrook

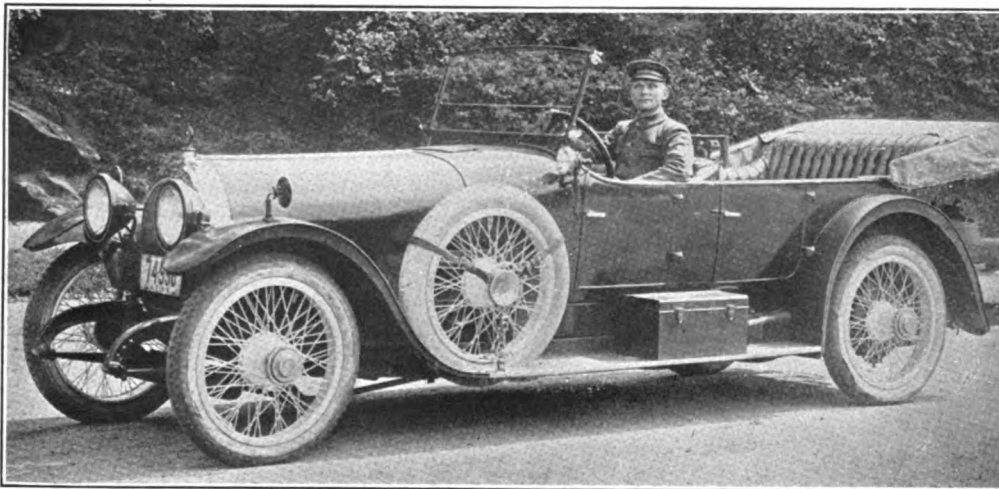

**TOURING CAR**  
Built by Simplex Automobile Co., New York City

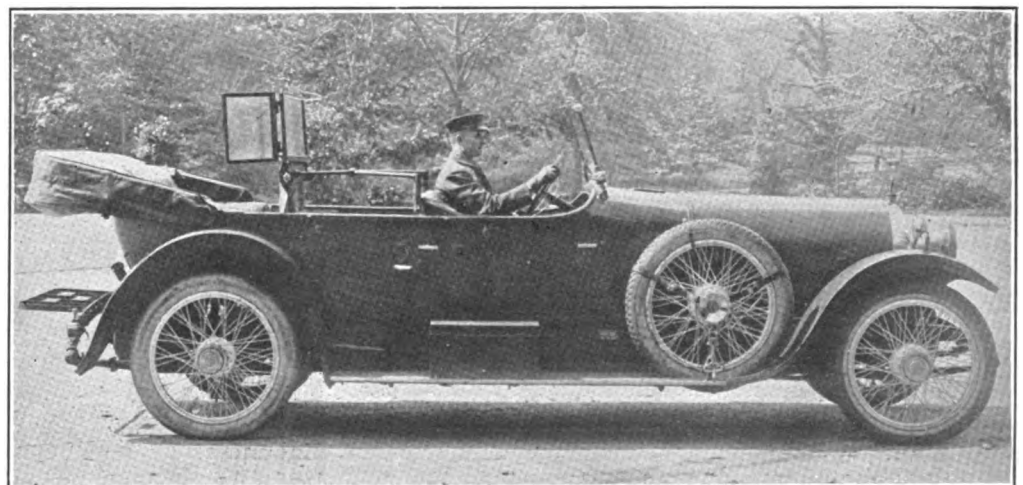

**TOURING CAR**  
Built by Simplex Automobile Co., New York City

**Repair Prices for Wheelwrights**

The following list of prices has been arranged by the Central States Jobbers' Credit Association for the benefit of those who do repair work. The figures are compiled by one of the most successful blacksmiths and wagon makers in the west.

**Wagon Ironwork**

Irons on Front Bolster.....	\$1.50
Irons on Hind Bolster.....	1.50
New Bolster End Irons, each bolster.....	.40
New Bolster Stake Irons, each stake.....	.80
1 pair Bolster Plates.....	2.00
1 New Sand Board Plate, put on.....	1.75
4 Wagon Tire, cut and set.....	3.50
4 Tire, re-set.....	3.50
4 Tire, re-set and bolted.....	4.50
4 Tire, pinned.....	3.50
4 Tire, 3-in., re-set.....	4.50
1 Rake Tire, re-set.....	.65
4 Log Wagon Tires, set.....	4.50
1 Set New Tires, 3 in.....	20.00
1 Set New Tires, 1 1/4 in.....	13.00
1 New Rub Iron, put on.....	.70
Old Tongue Iron, replaced.....	.75
Old Tongue Hound Irons, replaced, per pair.....	1.00
1 New Hind Hound Plate.....	1.25
New Hound Iron Braces, each.....	1.00
New Hammer Strap.....	.65
New Circle Post, each.....	.40
New Tongue Cap.....	.90
New Tongue Rod.....	.60
New Tongue Plate.....	.30
1 New Wagon Wrench.....	.60
Hub Bands, old, each.....	.20
Hub Bands, new, each.....	.40
King-bolt, each.....	.70
New Brake Shoes, put on, each.....	.60
Queen-bolt, each.....	1.00
Box Strap Irons, put on, each.....	.35
Seat Springs, each.....	1.20
Four 3/4 x 10 New Skeins, with boxing, put in.....	10.00
One New Skein, only put in.....	3.00
One New Skein, boxing only.....	1.50
Four 3/4 x 10 Steel Skeins, extra.....	4.00
One Brake Ratchet, put on.....	1.50
Top Iron on Box, bottom box.....	1.25
Box Rods, each.....	.35
New Center Clips on Singletrees, each.....	.35
New Ferrule on Singletrees, each.....	.30
New Neckyoke, center, each.....	.60
Neckyoke Ferrules, each.....	.30
Seat Hooks, set.....	.80
Rub Irons, not put on, each.....	.40
Hub Band, not put on, each.....	.35

**Wagon Woodwork**

Bolsters, front or hind, each.....	\$3.00
Bolster Stakes, front or hind, each.....	.60
Set of Rims, 1 1/4 in. tread.....	10.00
One-half Rim, 1 1/4 in. tread.....	2.00
Set of Rims, 2 1/2 x 2.....	12.00
One-half Rim, 2 1/2 x 2.....	2.10
Set Truck Rims, 3 x 1 1/4.....	13.00
One-half Rim, 3 x 1 1/4.....	2.25
Set Truck Rims, 4 x 1 1/4.....	16.00
One-half Rim, 4 x 1 1/4.....	2.40
Truck Felloes, 2 1/2 or 3 in., each.....	1.65
Truck Felloes, 3 1/2 or 4 in., each.....	2.00
Wagon Felloes, each.....	.60
Wagon Felloes, set.....	10.00
Spokes, Single, each.....	.40
Spokes, whole wheel, each.....	.35
Hubs, per set.....	7.00
Hubs, one.....	2.25
Reaches, 8 ft.....	1.60
Reach, 10 ft.....	1.85
Reaches, 12 ft.....	2.25
New Tongues, oak or ash, with old irons.....	4.65
Plow Tongues, oak or ash.....	3.75
Slegh Tongues, square.....	3.75
Harvester Tongues.....	5.50
Tongue Hounds, new, per pair.....	2.50
Tongue Hounds, new, each.....	1.50
Front Hounds, per pair.....	3.00
Front Hounds, each.....	1.75
Hind Hounds, per pair.....	3.00
Hind Hounds, each.....	1.75
Bent Hounds.....	4.50
Single-trees, each.....	.90
Double-trees, each.....	1.40
Neck-yokes, old irons.....	1.00
Hub, boxed, each.....	1.00
Axles, 3 1/2 x 4 1/4.....	Maple, \$5.00; Hickory 5.50
Axles, 4 x 5.....	Maple, \$5.50; Hickory 6.00
Sand Boards.....	2.50
Wagon Stakes.....	.50
Box Bottom, labor.....	3.00
Box Bottom, cross piece center.....	.90
Box Bottom, cross piece end.....	.60
Box Bottom, per set.....	6.00
Spring Seat, wood.....	3.75
Seats, old iron, each.....	1.85
Seats, new iron, each.....	6.00
Wagon Shafts, 1 1/4 x 2 1/4, each.....	3.40
Dump End Gate, each.....	2.00
Plain End Gate, each.....	1.60
Wheels Cut Down, per set complete, and old tires set.....	15.00
Setting Boxing, new.....	1.00
Setting Boxing, old.....	.60
Setting Skein, each.....	.75
Eveners, four-horse, 6 ft.....	2.75
Eveners, four-horse, 7 ft.....	3.00
Eveners, four-horse, 8 ft.....	3.25

Wagon Boxes, 12 in.....	17.00
Wagon Boxes, 14 in.....	18.00
Wagon Boxes, 16 in.....	22.00
Double Box, 12 and 14 in.....	27.50
Triple Box, 10, 12 and 14 in.....	33.00

**Buggy Ironwork**

Buggy Axles, put on, job complete, up to 1 in.....	10.00
Buggy Axles, each, put on, up to 1 in.....	3.00
Axles Set, each.....	1.25
Four Buggy Tires, set hot.....	3.75
Four Buggy Tires, set cold.....	3.00
Re-setting One Old Tire.....	.90
Four Buggy Tires, new.....	8.50
One Tire, new.....	2.50
Buggy Springs, welded, per leaf.....	1.00
Iron Replaced on Shafts.....	.60
Shaft Iron welded.....	.60
Shaft Shackles, each.....	.60
Shaft Eye.....	.90
Pole Irons, replaced.....	.90
Pole Circle Irons, replaced.....	.60
Pole Brace, welded.....	.90
Pole Eye.....	.90
New T Hammer Strap.....	.90
Axle Clip.....	.30
Saddle Clips.....	.30
Steel Bow Socket.....	1.25
One Buggy Single-tree Clevis.....	.30
One Buggy Single-tree Clevis Bolt.....	.15
One Buggy Single-tree Ferrules, each.....	.15
One Buggy Single-tree Cockeye, each.....	.15
One Buggy Clip King-bolt.....	1.25
One Buggy Reach, iron welded on old reach.....	.75
One New Whip Socket, put on.....	.60
One New Top Prop, put on.....	.75
One New Top Prop Nut, put on.....	.25
One New Bow Rivet.....	.20
One New Buggy Spring.....	\$2.75 to 3.75
One New Buggy Spring Clip, put on.....	.40
One New Buggy Shackle Clip, put on.....	1.00
Buggy Box in New Wheel, each.....	.75
Buggy Box in Old Wheel, each.....	.50

**Buggy Woodwork**

Shafts, New, with old irons, per pair.....	4.35
Shafts Ironed and Painted, complete.....	6.00
Shafts, Cross Bars, old irons.....	1.55
Shafts, New Express, each.....	3.10
Pole only.....	4.00
Pole, Ironed and Painted, complete, no neckyoke.....	8.00
Pole Circles, each.....	1.85
Buggy Single-trees.....	.85
Buggy Double-trees.....	1.25
Buggy Neckyokes.....	1.75
Patent Spokes, single, each.....	.40
Patent Spokes, four or more, each.....	.25
Rims, set 7/8 and 1 in.....	7.00
Rims, set over 1 in.....	8.50
One-half Rim.....	1.25
One Rim only.....	2.15
Axle Bed.....	1.65
Reach, single.....	1.40
Reach, pair.....	2.50
Head Block.....	1.85
Spring Bar, scrolled.....	1.85
Spring Bar, plain.....	1.35
Body Panel Side, one coat and priming.....	3.75
Body Panel End, one coat and priming.....	2.00
Wheels Cut Down, tire set, per set.....	12.00
Plano Box (one seat), with old irons.....	12.00
Spring Wagon Box, with two seats.....	16.00
Bow Sockets, each.....	1.25
Buggy and Surrey Dashes.....	\$1.85 to 4.35
Buggy Side Curtains, per pair.....	3.10
Surrey Side Curtains.....	\$6.00 to 7.00
Buggy Boots.....	\$1.25 to 2.50
Buggy Side Bars.....	\$1.85 to 2.50
Wood Buggy Bows, put in, each.....	2.15
New Wheel, complete, C grade, 1 in., with new tire, not painted.....	6.50
New Wheel, set, C grade, 1 in., with new tire, not painted.....	20.00
New Wheel, for 1 1/4 in., add extra per set.....	2.00
New Wheel, for 1 1/2 in., add extra.....	4.00
Buggy Seat, one new side.....	.90
Buggy Seat, one new back.....	1.50
Buggy Seat, one new piece in seat frame, each.....	.90

**Sled and Sleigh Work**

Pole, flat, replaced.....	5.00
Pole, square, replaced.....	5.00
Roller, replaced, per pair.....	3.25
Bench Beams, each.....	4.00
Reach or Short Tongue.....	1.50
Bolster.....	3.00
Runners, up to 2 x 4 in., old irons, each.....	4.00
Shoes, new, put on, steel, each.....	2.25
Beams, put in, each.....	3.25
Knees put in, each.....	1.25
Raves, each.....	1.25
Shoes Cast, put on, per set.....	10.00
Putting on Cast Shoes, one.....	2.50
Sled Stakes, each.....	.40

**British Car Census**

According to the annual census compiled by The Car, London, there are 266,683 motor vehicles registered in England and Wales, 45,098 in Scotland, and 20,116 in Ireland. As compared with the previous yearly census, these figures represent an increase of 33,420 for England and Wales, 5,820 for Scotland, and 3,175 for Ireland.



# Government Adopts Babcock U. S. Standard Ambulance

A contract for 500 ambulance bodies for motor trucks has been closed with the War Department by the H. H. Babcock Co., Watertown, N. Y. The contract calls for delivery within six months and will require the operation of the plant at full capacity till August 1. A sample car had been in operation in Washington for over a month and met full approval by the medical board of the army. Side and rear end views are reproduced herewith.

The company ascribes the placing of the order without competitive bidding to recognition by the government of the advantages of Babcock patented steel construction in respect to strength and light weight, having the great advantage of increasing the strength while reducing the weight over one-third. An X-ray of this body would reveal its skeleton of steel. The finest and toughest open-hearth angle steel is fitted and bolted securely to sill, cross-sill and upright. The remarkable saving of weight results from this blending of steel and wood. All irons are bolted or riveted and wherever strain occurs steel plates are placed between the bolt heads and the wood. There is steel reinforcement at all points exposed to wear or strain, but that reinforcement is not merely a brace or patch; it is essentially one with the rest of the body.

The ambulance will accommodate eight patients sitting or four prone.

The government's requirements demand a construction which must be such that injury to one part of the body will not necessitate the total loss

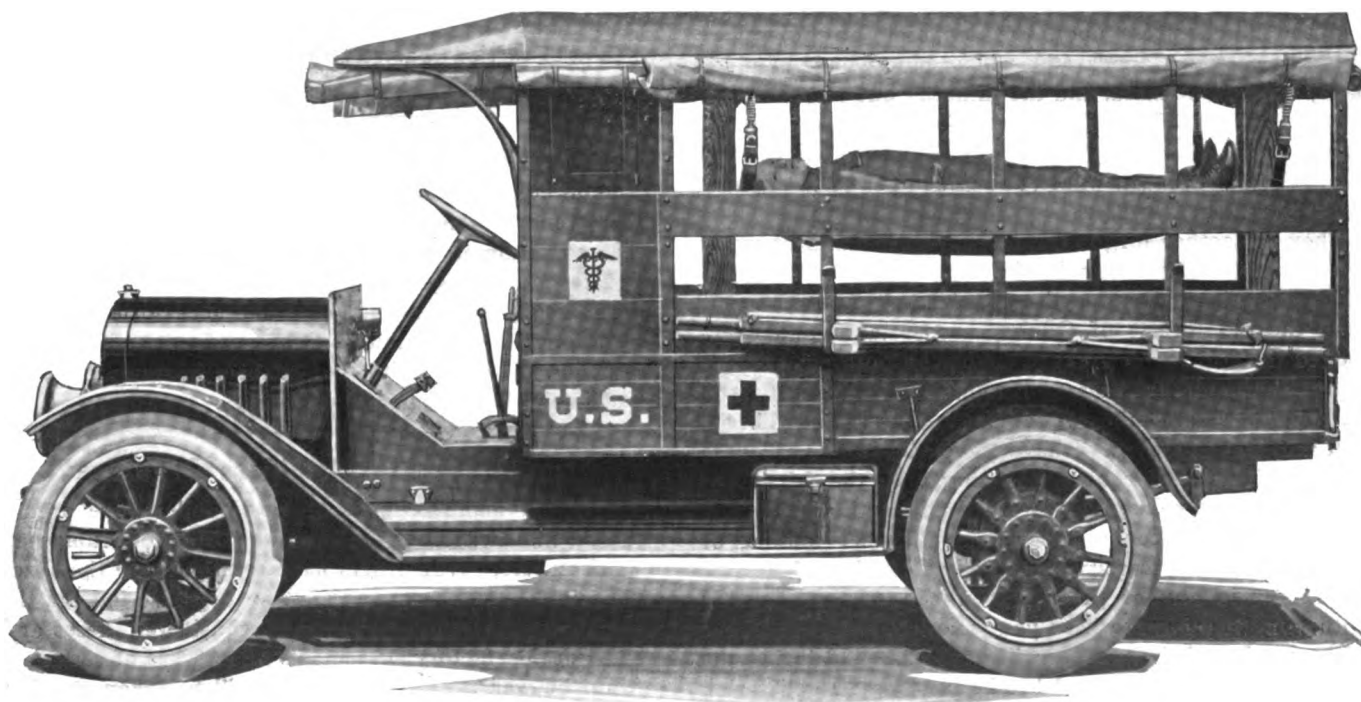
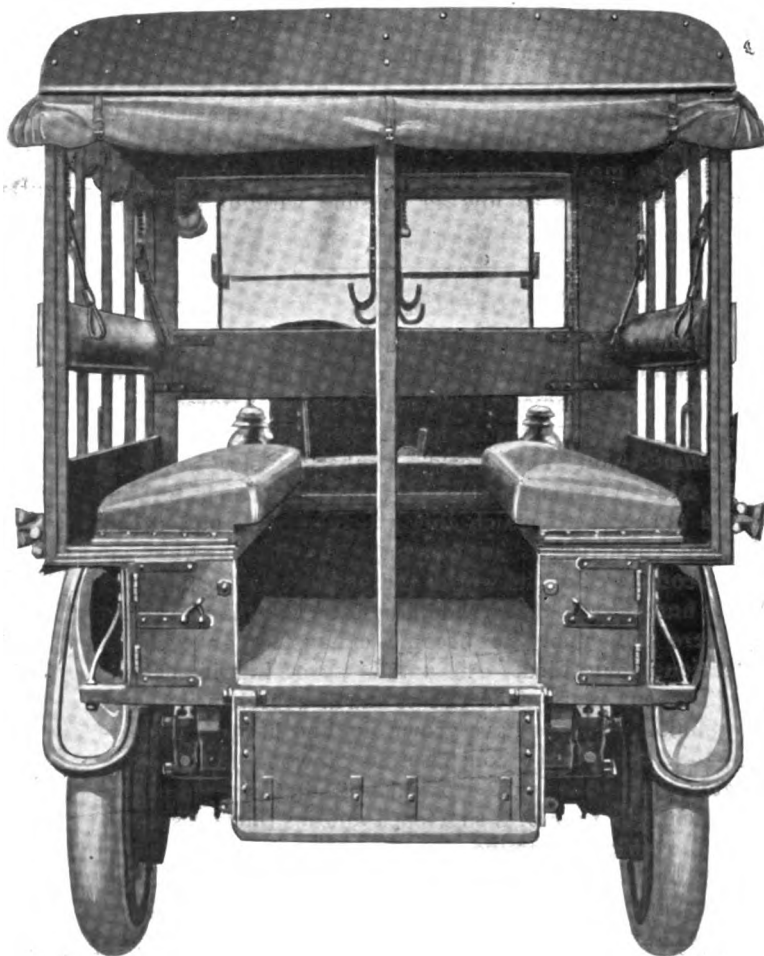

of the body, the quick replacement of the injured portion being absolutely essential.

The government specifications for ambulance bodies are such that the completed bodies can be mounted on few existing chassis—those few being of light weight construction, using pneumatic tires and permitting reasonably high speed.

In the government body there must be 96 in. behind the driver's seat, and the various other dimensions must be such that the required number of persons can be carried.

The Babcock company took the order on the basis of a very reasonable profit, in accordance with the policy adopted by most of our manufacturers of insuring the government prices as low as possible without affecting the quality of the product.

### Optimistic View of World's Timber Supply

Sir John Fleming, a past president of the Timber Trade Association of the United Kingdom, and a member of the Special Parliamentary Committee on Afforestation, recently delivered a lecture before the Aberdeen Chamber of Commerce on "The World's Timber Supply."

He said: A constant supply of suitable timber for the varied purposes to which this article is now put, in all civilized countries, is so necessary for the carrying on of the commerce of the world, and, indeed, for the comfort of the human race, that it would be little less than a calamity were the supply to become exhausted, or even to be seriously curtailed. The possibility of this happening has in recent years given rise to much apprehension, and the opinion seems to have grown up, and become intensified, that the world's consumption of wood has become greater than its annual growth, and that we were fast approaching a time of a shortened and insufficient supply, if not an absolute famine.

This opinion has been fostered partly from interested motives but has taken root mainly from an insufficient study of the situation. It has, of course, been strengthened since the war broke out, and timber has become so dear and so difficult to obtain. Those pessimists have laid too much stress upon the depletion of the timber limits of eastern Canada (the yellow pine woods of older days) on the one hand, and the thinning out of the woodlands of eastern Norway and southern Sweden on the other hand, woods which up to the sixties so easily supplied all our European wants, and which are certainly now much diminished in area.

They altogether forgot the much vaster limits of western Canada and Oregon in the new hemisphere, as yet little more than just tapped, and of much greater extent than the old forests of Quebec and Ottawa, and overlooked the still vaster areas of timber on both sides of the upper shores of the Gulf of Bothnia, not to mention the millions of square miles of forests in Russia and Siberia, still not even surveyed. I have traveled much in all these areas, although, of course, touching only the fringes of the forests, and have given careful study to their statistics.

I have never been a believer in a timber famine, or even of a timber scarcity, and today I am less than ever a believer in any of these possibilities. I would plead with you, therefore, to keep your minds easy on the score of a scarcity of timber. It will never happen during the lifetime of my hearers, and by the time a new generation has arisen, the rules and regulations for the conservation

and replanting of forests in old countries, and the laying down of railways and canals for the tapping of more distant interior supplies in new countries will have matured, and a famine, or even a scarcity, will then be impossible, if indeed, in the much longed for, and we trust long continuing piping times of peace, a day may not come when there will be over abundance of an article at present so scarce and dear.

### Annual Meeting of British Carriage Makers

At the 35th annual meeting of the Institute of British Carriage Manufacturers held at the Coach Makers' Hall in London, J. Orr Young, of Bromley, was elected president for 1917.

Mr. Young, in acknowledging the compliment, said that the first time he had entered the hall of the Coachmakers' Co. was in 1896, when he gained a prize given by the Coachmakers' Co., and he retained a vivid recollection of the way they were entertained on that occasion by their hosts. He referred to the possibilities which the developments of aviation offered to the trade, in the way of supplying aeroplane frames and accessories, this being an industry to which they might well pay attention just now.

The result of the voting for vice-president and members of the council was then announced, the scrutineer reporting that for vice-presidents the choice had fallen on Messrs. Maythorn, Norris, and Eberle, while for membership of the council the selection was Messrs. Alford, Hampson, McCormack, Pierce, Withers, and Moreton White.

The officers of the institute were next reelected.

The secretary read some correspondence he had had with coach builders' associations in Australia on the subject of affiliation to the institute.

Mr. Hamshaw stated that replies had been received from the Coachbuilders', Wheelwrights' and Motor Body Builders' Association of New South Wales, and the Coachbuilders' Association of Melbourne, Victoria, cordially entertaining the proposals made to them and undertaking to reciprocate in any way they could.

Mr. Thrupp said that the idea of affiliation with kindred societies abroad was an excellent one, and made a motion which was carried that steps be taken to carry the suggestion into effect.

### Mexico Removes Import Duties

The de facto government of Mexico has issued a decree which went into immediate effect removing the import duties on automobiles and all other motor vehicles.

Several months ago the Carranza government increased the import duties on automobiles and accessories to what was practically a prohibitive figure and what little trade was being carried on with that country in these lines was immediately discontinued as a result.

### Hungarian Auto Builders Organize

Hungarian manufacturers of automobiles have organized as a sub-division of the National Union of Hungarian Manufacturers. War orders have so stimulated the automobile industry in Hungary that an organization for the protection of manufacturers was considered necessary. Import duties, factory agreements as to types of cars used during the war, are questions that will be taken up after the cessation of hostilities.



## Making the Executive More Efficient

### Use of Charts on the "Exception Principle" to Save Manager's Time and Develop Personal Contacts With Employees

By Frank B. Gilbreth\*

We have stated many times that the greatest waste in the world today is from unnecessary, inefficient and ill-directed motions. Many people think that this statement refers only to such activities as those of the bricklayer, the shopworker and other kinds of mechanics and manual workers. It does refer to them, but also to managers and all other executives.

To one trained in the sciences of management and motion study, nothing is more ridiculous and pitiful than the average executive when he tries to enforce new motion methods on those farthest below him on the industrial scale, while he at the same time commits nearly all the motion wastes in his own personal work. The personal work of the executive should consist, as much as possible, of making decisions, and, as little as possible, of making motions. General recognition of this fact has resulted in

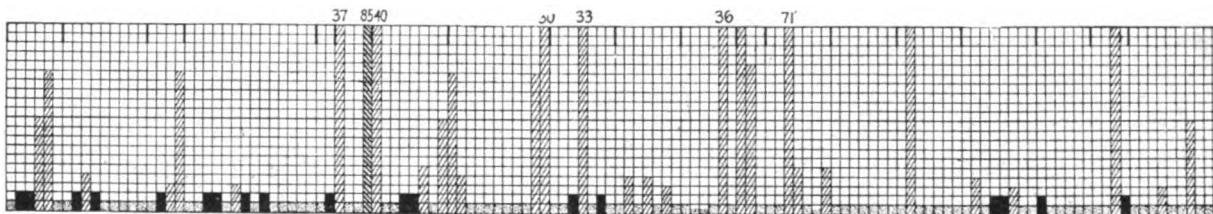

As a simple illustration of a chart used on the exception principle, the above has been obtained from Mr. Gilbreth. It may, for example, show the promptness of performance of an information bureau of a factory in charge, say, of trade publications, estimates of work under consideration and records of design sketches. Each horizontal space may represent a specific request for information and each vertical space the time required to supply it. Colors may be used to indicate notable time differences. The point of the exception principle is that the chart shows at a glance when it

by the use of graphical charts. He should provide himself with charts which will tell how much time has elapsed between the completion of the output and the recording of it and its attending costs. The by-products of a properly operated chart system are even more valuable than its direct product. We find that the psychological effect of the variable "promptness" itself makes the curves representing outputs and costs fall more nearly in the proximity of the locations prophesied on the charts. Such charts give the executive and his colleagues accurate measured information of deviations from class in all departments. The motions that an executive would expend in getting information by such old methods as, for example, walking through the works to see with his unreliable eyes conditions which are not typical, partly owing to his presence, brings results of little value compared with the results that can be obtained by the same amount of time and motions concentrated on these facts and conditions which cause the great fluctuations from the desired output.

While this fact is generally recognized, the number of installations of chart departments throughout the country

took too long for a definite inquiry. Then it may be the duty of one individual to ascertain why, for instance, as long as 10 minutes was necessary and another when the time is, say, 20 minutes. In the so-called three-position plan of management (in which the occupant of any particular job gets supervision from the one promoted from it and serves as a tutor to one in line to fill it), the result is an effort to keep the time intervals within the safety zone so to speak, so that No. 1 of the three-position plan is not likely to be demoted to improve the service.

the common practice of assigning to the executive one or more secretaries, or clerks, to relieve him of certain parts of his work which involve more motions and less important decisions than that part of the work retained by the executive.

#### What a Chart Should Show

Some executives are furnished with charts which show by means of comparable curves the increase or diminution in output, cost, overhead expense and, in comparatively rare instances, even in results as compared with budgets. As compared with an organization which has no cost system, such as recapitulation, even in the form of an "expenditure system," and such cost statements and graphical charts are a great step forward. No cost system nor chart system, however, can be considered really satisfactory unless it determines and shows:

1. What the quantities of individual outputs should be (prophecies of outputs).
2. Prompt records of individual outputs.
3. What the costs should be (prophecies of costs).
4. Prompt records of costs.
5. Causes of fluctuations and deviations of outputs and costs from prophesied outputs and costs.

The executive may have much to do with originally determining items 1 and 3; but after the computations of 1 and 3 have been completed, he can best attack the problem of enforcing items 2 and 4 and, also, of determining 5

is increasing with surprising slowness. Even in those organizations where there is a satisfactory cost system supplemented by charts with curves, showing results as compared with expected conditions and ideals, the executive too often finds himself flooded with charts. Then, being human, he postpones studying them. As a result, many benefits which come from promptly making records of outputs and costs are lost by his delayed action. It is here that the "control on the exception principle" plays the important part.

It is obvious that the foreman, or other functionary, should see promptly all the records of output in his particular department. In most cases he will be able to handle his duties still more satisfactorily if he, also, sees the costs of the output of his department. The time of the over-foreman, however, who may have several foremen and departments under him, is too valuable to have him, also, examine with care all the records of all the men under him. Consequently, he should be furnished with information in concise form, in order that as little as possible of his time may be taken. This has often been furnished him in the form of averages.

#### The Use of Averages

Ordinary averages have their use. Progressive averages are, however, more valuable, because they show the trend of progress and efficiency. It sometimes pays to make ordinary averages, but the value of examining such ordinary averages is slight compared with the benefits

\*Consulting engineer, Providence, R. I. From a paper read before the American Society of Mechanical Engineers.

which result from concentrating the same amount of motions and attention on those individual cases that brought the average away from the ideal. A case of "bad average" may be the excuse for putting the foreman "on the carpet," but the results of this do not compare with the good results that are derived from having the over-foreman investigate promptly the case or cases that spoiled the average. Moreover, the decisions of the over-foreman can be made more quickly, for he has the information which comes from locating the trouble accurately. Instead of "tearing out" the foreman or the workman, he will find, from the causes marked on the chart, that the worker's low output is due to lack of the proper tools, to his not having been furnished with tools in standard conditions, to the routing system having failed to give him proper materials in the right quantities, in the right sequence and at the right time, to something which has gone wrong with the equipment or surrounding conditions; to the man's not having been properly instructed; to there having been an unwise selection of the man or the machine, or both, for the particular job.

The worker, also, is more careful not to do anything

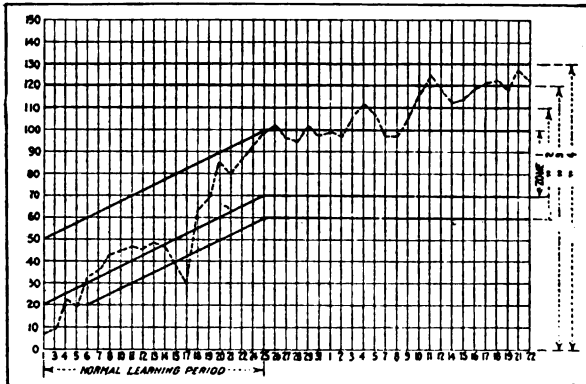

Another example of the exception principle chart may cover the output of a single worker, including his learning period. Zones are established so that points of performance falling below or above certain limits come automatically by that fact to the attention of certain individuals. The lower the record or the higher the record the higher in the industrial management scale will be the individual who must inquire into the conditions. The results may indicate poor instruction or incompetency in foremanship or they may bring the executive into personal contact with the worker in the matter of commendation for unusually high performance.

which is not expected of him, because he knows that the exception will surely be noticed by the executives higher up and will interfere with his chances for promotion or transfer to work of a more desirable kind. Knowing that they will be investigated properly will create a tendency on the part of the foreman and the workers to cooperate with others whose work affects theirs, or who in turn may be investigated. This co-operation becomes general and sooner or later becomes a habit.

**The Exception Principle**

Now the time of the executive next above the over-foreman is still more valuable than that of the over-foreman, and so on up to and including the managing director or president. No executive should make a routine motion of handling, turning over or examining charts containing data, either normal or with considerable deviation from class, where the clauses of the deviation can be handled properly by those in lower executive positions. The exclusion of such cases can be obtained by having the executives determine zones on the charts, it being understood that as long as the points fall within the zone, he is not to see the charts unless he specially requests to see them.

He is, however, to have sent to him any chart having a point that falls outside the excluded zone.

An executive of any class will find it beneficial to see exceptionally large cases of deviation on the desired side of the line so that he can recognize and appreciate and take a personal interest in cases of unusual efficiency. It is through such cases that he gets in touch with unusually good methods. This is a check on the Time Study Man's work. It also gives the executive valuable opportunities for proper managerial decisions in cases of the selection of candidates for promotion under the "three position plan" of organization building, in which every man is not only attending to his present job, but is training himself for the next higher job and keeping a watchful eye on his successor in his previous job. The curves showing progressive averages of departments may be examined at times farther and farther apart, these intervals to be determined in each particular case by the favorable or unfavorable comparison of records of such averages showing outputs and costs with the prophesied outputs and costs. The executive is thus relieved later of work which is necessary at first but which is not necessary when the particular case is running satisfactorily.

It is impossible to prophesy with accuracy what the amounts of outputs and costs should be without motion study and time study. But once these have been made and the actual outputs and actual costs approximate those prophesied, the high executives should devote very little time indeed to inspecting this class of charts. Instead they should spend their time on other work, other departments and more important things where their supervision will bring more valuable results.

It will be seen that these "Output, Cost and Causes Charts" with Exclusion Zones enable the executive to eliminate the motions required for general oversight and inspection until a place on a chart is brought to his attention where he can actually help those below him and furnish them with better instructions for handling their work more efficiently, or for making such changes as will naturally result in promotion or the selection or shifting of individuals better fitted to do work elsewhere. The possibilities of relieving the executive of unnecessary motions and of enabling him to be more efficient in his own work are not exceeded in the case of any manual worker.

**Trucks Fees Based on Capacity**

Passenger cars and truck taxes in Texas will undergo a change on July 1, 1917, according to a bill which has just passed the legislature. All automobiles and trucks will be subject to a graduated fee or tax. Passenger cars will be taxed 35 cents per horsepower, the minimum fee being \$7.50. Trucks will be taxed according to the carrying capacity per wheel, as follows:

Weight in pounds per wheel	Fee
1,001 to 2,000	\$20
2,001 to 4,000	40
4,001 to 6,000	60
6,001 to 8,000	150
8,001 to 10,000	300

For loads greater than 10,000 lbs. per wheel, license fees shall be charged for each vehicle at the additional rate of \$500 for each 1,000 lbs. increase in weight, or a fraction thereof, with the provision, however, that no load greater than 800 lbs. per inch width of tire per wheel shall in any case be permitted, and also that no vehicles of a total gross weight of more than 14 tons shall be licensed by the highway commission.

## Manganese Bronze—Its Structure and Utility

The word bronze, so often loosely applied, covers several alloys of different composition. Ordinarily, a bronze may be regarded as a compound or mixture of copper 80 to 90 per cent, and tin 20 or 10 per cent, being then rather brassy in character. Instead of tin being used, lead or zinc may be substituted, thereby giving the metal other distinct properties. In many circles, however, bronze is considered to contain more zinc than tin or lead.

In cases where the name is prefixed by a companion one indicating a special element, it does not follow that the latter is in any way abundant, but only that it confers its own merits on the alloy of which it is a constituent. Such an example is under consideration in the following notes.

Manganese bronze has proved very satisfactory as a bearing metal, also for certain types of valves, and in other directions where heat, due to friction or other causes, is encountered. A very excellent manganese bronze consists of copper, 58 to 60 per cent; zinc, 39 to 41 per cent; tin, iron, and aluminum, 1 per cent each; and manganese up to 2 per cent. The last-mentioned metal may in some instances exist in mere traces, and yet exert a wonderful influence in rendering the alloy non-corrodible, strong, and exceptionally hard.

The manganese is generally added to the other metals in the form of ferro-manganese or cupro-manganese. It

Even when the relative quantities of the different metals are eminently suitable to one another, wrong handling may injuriously affect their ultimate properties. If the molten substance is too hot, or is poured too rapidly, the resultant alloys are unbalanced, and when exposed to friction in the solid state overheat in parts, while others are scarcely warm, and "copper-spotting" then becomes unduly prevalent.

If kept molten too long large crystals make their appearance in the solidifying mass, bringing drawbacks that are absent when the crystals formed are smaller, as is the case when slower pouring is practiced; the alloy then cools at a quicker rate. Here, also, care is required, since too slow pouring encourages the development of little round non-coherent nodules, and corresponding pits—a formation that is known as "shot" metal.

The comparatively large, coarse, crystals that occur through too rapid pouring fracture readily, when the metal is cold, and reworking may produce dangerous results. Considerable attention has to be given to the zinc constituent, because if it is at all in excess it is liable to cause seizing in parts such as bearings where friction occurs. Particles may also become loosened and give rise to gritty residues. A surface worn in this way is shown in Fig. 2.

Tin has a tendency to make any alloy containing it brittle, owing to its refusal properly to compound with other elements. Beyond 13 per cent it becomes extremely ob-



Fig. 1—Magnified surface of rough cast manganese bronze showing the semi-crystalline structure. Magnified 48 diameters

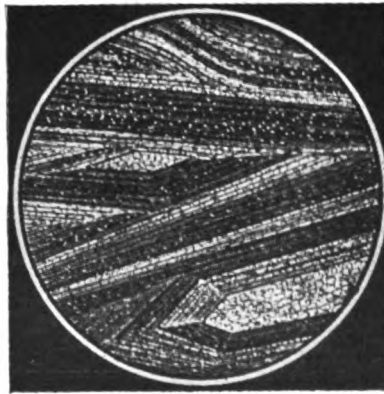

Fig. 2—Magnified surface of manganese bronze after being slightly scratched by grit. Magnified 48 diameters

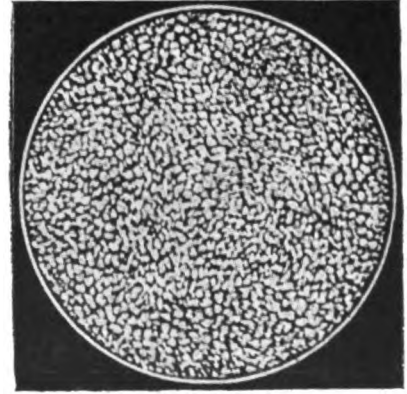

Fig. 3—Magnified surface of polished manganese bronze after being etched with dilute nitric acid. Magnified 48 diameters

has been proved that the iron contained in the first of these crude products does not affect the final alloy in any particular manner. The manganese is used thus more for convenience than anything else.

If the proportions of manganese should exceed 4 per cent the alloy is apt to wear badly, but under this amount—preferably in the neighborhood of 2 per cent—good castings of superior properties may be produced. Confusion with manganese copper should be avoided in this connection. Manganese bronze belongs to the series of copper-zinc alloys.

Copper is not suitable for many of the purposes in which bronze containing it happens to be extremely suitable. This strange fact is due to the compounding of the copper with the other elements, which reduce its normal softness, while not interfering with its other qualities to any noticeable extent. If, however, the proportion of copper is not kept within correct percentages it is likely to be pressed out of its position, and segregate irregularly, forming what are known as "copper-spots."

jectionable, and its defects cannot be controlled by additions of other metals.

Manganese bronze is highly serviceable where heavy loads are carried, as it is very hard, solid, and homogeneous. In certain cases softer anti-friction metals may be run into arranged cavities, but such system must not be adopted without care, as the softer metal may be squeezed into important corners, and tend to clog and bind the bearing. Judiciously used it is very serviceable; but not so beyond certain limits.

It should be noted that when the surface of an alloy (or any metal for that matter) is ground and polished, the interstices between the individual grains are filled up by the microscopical particles of dust rubbed off. These are practically fused into position by the heat evolved. The grain of the metal itself cannot be properly observed until the specimen is etched, and the film removed by means of acids or other chemical reagents. These reagents clear out the channels between the grains, as explained later on.

In examining the outside of a sample of newly cast manganese bronze it appeared as shown in No. 1, the coarse formations being crystalline growths between which were minute pores due to escaping gases. It does not follow, says Automobile Engineering, of London, Eng., that the presence of these little orifices signifies an inferior internal structure. Indeed, if they were not visible, we might conclude that globules of gas still remained inside the solid mass. The metallurgist has to decide from his experience concerning this phase as to the quality of the alloy.

Manganese bronze has a very bright attractive appearance when polished, the surface being hard, unyielding, and tough. Nothing particular can be discerned in it when magnified except the extremely fine lines occasioned by the abrasive, but after the action of a suitable acid upon it the substance is so resolved that its true formation can be seen.

As stated elsewhere, it is by chemical treatment that alloys are analyzed, and while these notes are not intended to be analytical, the details given will convey some idea of the possibility of ascertaining the structure, or degree of compounding, of the metal.

Free copper dissolved in nitric acid produces a blue copper salt, copper nitrate; zinc in nitric acid gives white zinc nitrate; lead, white lead nitrate; tin, white tin nitrate; iron, brown iron nitrate; aluminum (will not dissolve in nitric acid); and manganese, white manganese nitrate.

Particles of isolated metals which had been improperly alloyed would yield these characteristic results. Combinations, however, disclose colors that might mislead the observer who relied on this test alone. Metals in some instances get practically amalgamated indistinguishably, so far as physical aspect goes, but allow their components to be dissolved out separately. This is a matter on which no hard and fast rule can be made.

The strong nitric acid itself, put in drops on the cleaned surface of manganese bronze, caused first a greenish elevation which gradually changed to a reddish, almost crimson tint, except round the margins, where the initial one remained. Later on this rim also turned red.

When dilute nitric acid was spread over the polished surface of the alloy there was evolved a pale rusty patch with a dark brown edge. By washing off the crystalline salts thus formed the modified or revealed metal disclosed its grains very well, as shown in No. 3. When the particles of an alloy are so regular, equidistant, and minute, the formation can be regarded as quite a satisfactory one, provided other features are also reliable. Upon standing manganese bronze in dilute nitric acid for some hours it did not appear to alter the surface to much extent until removed and dried, when black and brownish areas were revealed.

---

### Standard Parts Closes Deal for Western Spring

The purchase of the Western Spring & Axle Co. by the Standard Parts Co., Cleveland, has been announced by President Christian Girl of that company.

The Western Spring & Axle Co. was originally a Cincinnati concern. It has been manufacturing springs and axles for carriages for 50 years and more recently for automobiles. In many respects it resembled the Standard company, being a combination of manufacturers of

springs, axles, bearings and similar parts. Its properties consist of the Armstrong plant at Flint, Mich.; Hess-Pontiac plant at Canton, O.; Cleveland-Canton Spring Co., also in Canton; the Hess Spring & Axle Co. at Carthage, O.; the Bock Company, and plants in Wheeling, W. Va.; St. Louis, Mo., and Connersville, Ind. Negotiations for the acquisition of the company were started last winter.

Mr. Girl stated that the acquisition of the Western completes the original program for the parts organization, and that the Standard Parts Co. will now be developed and rounded out on the basis of the companies now represented. These include the Perfection Spring Co., the Standard Welding Co., the Bock Bearing Co., Toledo, and the Western Spring & Axle Co.

J. E. Hess, president of the Western company, becomes a member of the board of directors of the Standard company, as does W. E. Bock, of the Bock Bearing Co., a Western subsidiary. John A. Kling and Maynard H. Murch, the latter a Bock director, also have been added to the Standard board as a result of the purchase.

Executives immediately in charge of the several units of the Standard Parts organization will retain their offices at their respective plants. J. C. Manternach, for four years past general manager of the former Standard Welding Co., is now general manager of the rim and tool division, which virtually replaces the Standard Welding. W. E. Perrine, who has been manager of No. 2 plant of the Perfection Spring Co., is now general manager of the Perfection Spring division of the Parts company.

New appointments made by Christian Girl, president, include R. Finkenstaedt, assistant to the president; J. Gutz, chief engineer; D. C. Swander, director of sales; H. H. Newhom, director of purchases; J. A. Barben, manager of publicity, and J. A. Liston, manager of the jobbing department. An auditor will be appointed in the near future. Mr. Swander was formerly Firestone eastern sales manager. Mr. Liston was formerly Thermoid western sales manager.

---

### Gear Manufacturers Organize

Several manufacturers of gears early in April formed the American Gear Manufacturers' Association, meeting at Lakewood, N. J., for the purpose. Such an organization had been talked about quietly by the firms concerned, who realized the advantages to be secured by close association, and the organization now is going quietly about its affairs. As explained by one of the organizers, these will consist of promoting the interests of the gear industry by the standardization of gear design, manufacture and application.

Officers of the A. G. M. A. are as follows: President, F. W. Sinram, Van Dorn & Dutton Co., Cleveland, O.; vice-president, H. E. Eberhardt, Newark Gear Cutting Machine Co., Newark, N. J.; secretary, F. D. Hamlin, Earle Gear & Machine Co., Philadelphia, Pa.; treasurer, Frank Horsburgh, Horsburgh & Scott, Cleveland, O. The executive committee consists of the officers, with Biddle Arthur, Simonds Mfg. Co., Pittsburgh, Pa.; Geo. L. Markland, Philadelphia Gear Works, Philadelphia, Pa., and Milton Rupert, R. D. Nuttall Co., Pittsburgh, Pa.

---

Michigan Hearse & Motor Co., Grand Rapids, Mich., will build a brick and steel factory to cost \$18,000.

## Setting Up a Motor Car Top

Set up, either to scale or full size, the side and front elevations within a rectangle, the lines of which form boundaries for the desired limits and extreme measurements of the hood. Dealing with the rectangle. First set out the outline of the top portion of the body; or, if developing a hood drawing on a body drawing, begin by fixing the height by a horizontal line at the desired height above the seat; 42 in. is a popular measurement.

A vertical front line at a suitable distance forward of the screen will fix the extreme front of the hood. A vertical line two inches more or less beyond the rear of the seat, according to the shape or style of the body, provides for flare of the back. Next draw a parallel line 10 in. (or less if a small hood) below the top line to indicate the bottom of the valance of the hood covering.

Fixing the position of the main pivot center is dependent on four things, viz., distance from that center to the extreme top, rear-most point on the back of the seat, the seat bottom frame and the available space between the front bow and the screen when the hood is up.

If you fix the main center too low, the bows will be too long and project too far beyond the rear of the seat, unless the center is set well forward. If you fix too high the bows will be too short, and the center will require to be set well back to allow the shortest bow to fold over the rear of the seat.

The position of the hood when folded requires consideration. A low position is favored so that the folded hood is practically level with the top of the seat. When the envelope is drawn over the hood everything should be trim and snug, and not likely to catch the wind.

To fix the bottom line of the rectangle remains. We find that line by taking a finger plate and pivoting it in position on the full size drawing, or drawing it to scale as required. Draw the curved line representing the top of the hood, and space the bows to suit as nearly equidistant as possible, though not essential. When the fingers are pointing in the right direction, outline them by running a mark all around. Now close and move to the position of the bottom line of the rectangle. The bows should not be below this line at the rear extreme, but rather a little above.

The elevation of the support is now obvious, and its distance from the main center should be as long as possible without fouling the valance, where fastened to the rear bow.

The length of the extension bow and the slide rod is governed by the erect position of the front bow, and the

folded position of the hood. The front elevation gives the width of the bows and distance between main centers. The length of the bows is easily measured, and may be written adjacent to them on the drawing. To mark off the bows for dressing, lay each one on the bench, the two ends upmost, and apply two cramps as far apart as possible. Hold the bow in a vertical position, with the rule standing on the bench flat against the bow, and tick off the required measurement. Mark all cut-offs by this method, and, when erecting the hood frame, space the bows at the top, according to the positions given on the drawing. No altering will be required if carefully carried

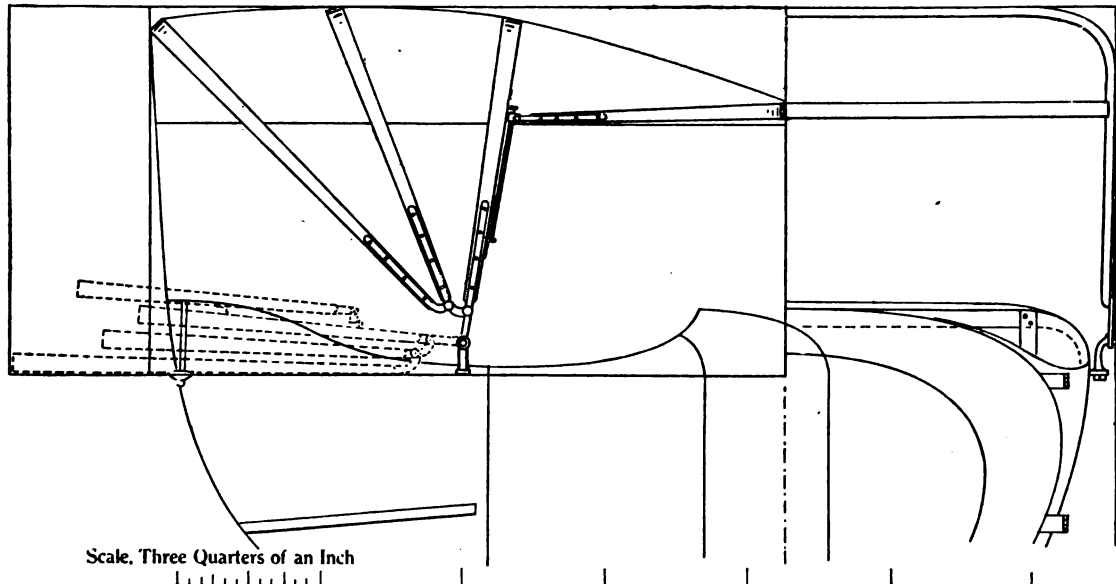

out. The trimmer may execute his work without asking for alterations.

Hoods mounted on five-seat cars are set out by the same system. Fix the limits by a rectangle of four lines to whatever is required, and erect the bows to the best advantage.

Three inch scale drawings on paper are worth making. They may be filed for future reference. When one has a few on hand there is generally one of them that will suit almost any job.—Australasian Coachbuilder and Wheelwright.

## German Mail to Dead Letter Office

All mail destined for Germany already received and that which may be mailed or received hereafter, will be sent to the Division of Dead Letters, Post Office Department, Washington, D. C., for return to the senders or other appropriate disposal. In view of the fact that mail for Austria, Hungary, Luxemburg, Bulgaria and Turkey requires transit through Germany, mail for those countries will be treated in the same manner as that for Germany.

## Electricians Gain in England

Electric vehicles are in much more general use in England than at the beginning of the war. When hostilities first began there was barely 150 electric passenger cars and trucks in use in that country. Now there are over 1,000. The reason for this increase is that all gasoline cars and trucks were needed for war work and a large percentage were shipped into France for use at the front.

### Slipper Type Piston

Harry R. Ricardo, B. A., A.M.I.C.E., a Britisher of acknowledged authority on engine design, has invented a novel form of piston in which the skirt consists of two perforated slippers.

The material of which it is constructed is an aluminum alloy; this for two reasons—first, for lightness, and secondly, because of the desirability of dissipating heat from the skirt, which, as will be seen, is only half a skirt. Aluminum possesses the quality of heat dispersal in a marked degree, and it is doubtful if an iron or steel piston with such a small bearing surface would be able to keep the piston head sufficiently cool to prevent preignition and other allied troubles.

The actual side pressure on a piston during the cycle comes, of course, only on the two parts of the cylinder walls which may be considered as parallel to the gudgeon pin, not to those at right angles thereto.

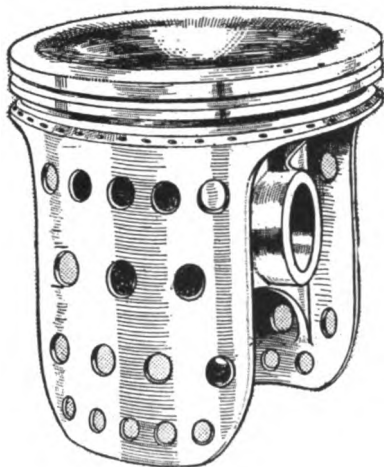

A unique form of piston in which the skirt consists of two perforated slippers

Considered merely as bearing surfaces, therefore, the two last-mentioned parts of the skirt are valueless, and can be dispensed with. By doing so, the area of the film of oil to be sheared is at once cut down by one-half, which is the sole object of the design.

It will be seen that two piston ring grooves are provided, the lower of which is chamfered at its bottom

edge, and that the beveled portion is furnished with a number of holes. This feature serves two purposes; first, it allows the lower edge of the piston ring to scrape off superfluous oil from the cylinder walls, and secondly, it prevents any gas that may leak past the rings from mixing with the oil comprising the oil film. This second reason is of some importance, since the friction of the mixture would be greater than that of the oil alone, and thus the main object, that is, the minimizing of friction, would to some extent be defeated.

By means of internal webs, clearly shown in the sketch, the vertical thrust due to the expansion of the working charge is taken by the gudgeon pin, there being consequently no distortion of the skirt from this cause. The webs also serve as radiators, keeping the interior of the piston comparatively cool and preventing the deposition of carbon.

Results of tests in comparison with a piston of normal design show an advantage in power output from a stated engine of about 8 per cent at 4,000 r.p.m., and approximately 10 per cent at 4,500 r.p.m. At lower speeds the advantage though less, is always appreciable. In respect of gasoline consumption, too, the advantage is pronounced; at high speeds the fuel per b.h.p. being .55 lb., as against .61 lb with normal pistons. There is said to be a similar gain in regard to oil consumption.

### Military Truck Specifications Revised

The War Department committee on revising specifications for military trucks has completed its work and the full specifications are now being printed for circulation. Much assistance was given the committee by the S. A. E. The specifications are similar to those for the 1½-ton truck issued last year. While there have been many detail changes the specifications are not so stringent. Following are the principal features of the new truck:

Four-cylinder engine, 312 cu. in. piston displacement.

Poppet valves only.

Pressure lubrication.

Disc clutch.

Four speed transmission with low gear ratio of at least 40 to 1.

Preferably worm final drive.

Highest possible clearance, minimum at center about 14 in.

Some form of locking differential acting automatically to prevent wheel spinning.

Electric lighting equipment.

Radiator about twice the size normally used.

36 x 4 in. tires, must be demountable.

Interchangeability of radiators, gasoline tanks and body attaching devices are points and the qualities of materials that must be used are specified, most strongly for such vital parts as the springs.

The War Department means to get these trucks in accordance with specification, and not be forced to take the nearest commercial product, as happened last year.

The War Department intends to order enough trucks to the present specifications to make it worth the while of manufacturers to arrange for their production, even though they cannot use more than a part of units which now go into the standard machine.

### J. H. Williams & Co. to Employes

Employes of J. H. Williams & Co., manufacturers of drop forgings, have received the following notice, which was posted at the Brooklyn and Buffalo, N. Y., plants and at the offices in Chicago: "In the present crisis in our relations with the German government it is the purpose of this company to treat all of its employes alike, regardless of nationality of birth or descent. The company expects from all in its employ the same loyalty that has been proved so often in the past, and takes it for granted that this loyalty will be extended in even greater measure to the policies of the United States government. We cannot do otherwise than endorse the suggestion of the President that we all, in our various relations with each other, allow no accident of heredity to influence our feelings at this time toward those who are loyal American citizens."

J. H. Williams & Co. have decided to guarantee for one year the payment of 50 per cent of wages or salaries to men enlisting who have families, and 25 per cent to unmarried men.

### Italian Automobile Output

The production of motor cars in Italy has quadrupled since the war commenced, according to a statement recently made by the Italian prime minister during the course of an address on industrial conditions in that country.



### Wholesale Delivery Van

With the advent of motor transport, the progress made during recent years in the art and craft of van body building has resulted in a production with which the work of no other decades can be compared. It is more than probable that the better class of work now in evidence is to a great extent due to the mechanical transport methods, and we find the general efficiency, durability of construction and finish superior in the motor to that of the horse-drawn van type of wagon. In building a horse-drawn vehicle the wheelwright had to figure the weight to be carried, the size and number of horses, height of the wheels, work required and many other incidental considerations. In the mechanical-driven body a totally different set of conditions to work from appears, as the body is bolted to the chassis frame, or cross bearers connected

There is a slot ventilator on each side of the body near the top rail, to allow a good circulation of air in the body. At the forward end of the body on each side is a hinged door, which gives access to the body and will be found to be of great importance. At the rear of the body are two hinged doors, with a van trip bar lock which is operated by a handle. The length of the body is 12 ft. The length of cab is 3 ft. 6 in. Height of body is 5 ft. 9 in., the floor being 9 in. above the chassis frame. The height of the cab is 5 ft. 2 in. This is a plain panel body throughout. The proper measurements and construction are carefully worked out in the working draft as shown. This type of van can be used in most every line of trade as the body will carry boxes, barrels, crates, etc. There is a rail on the top of the body which will permit the carrying of parcels, boxes, etc., if desired.

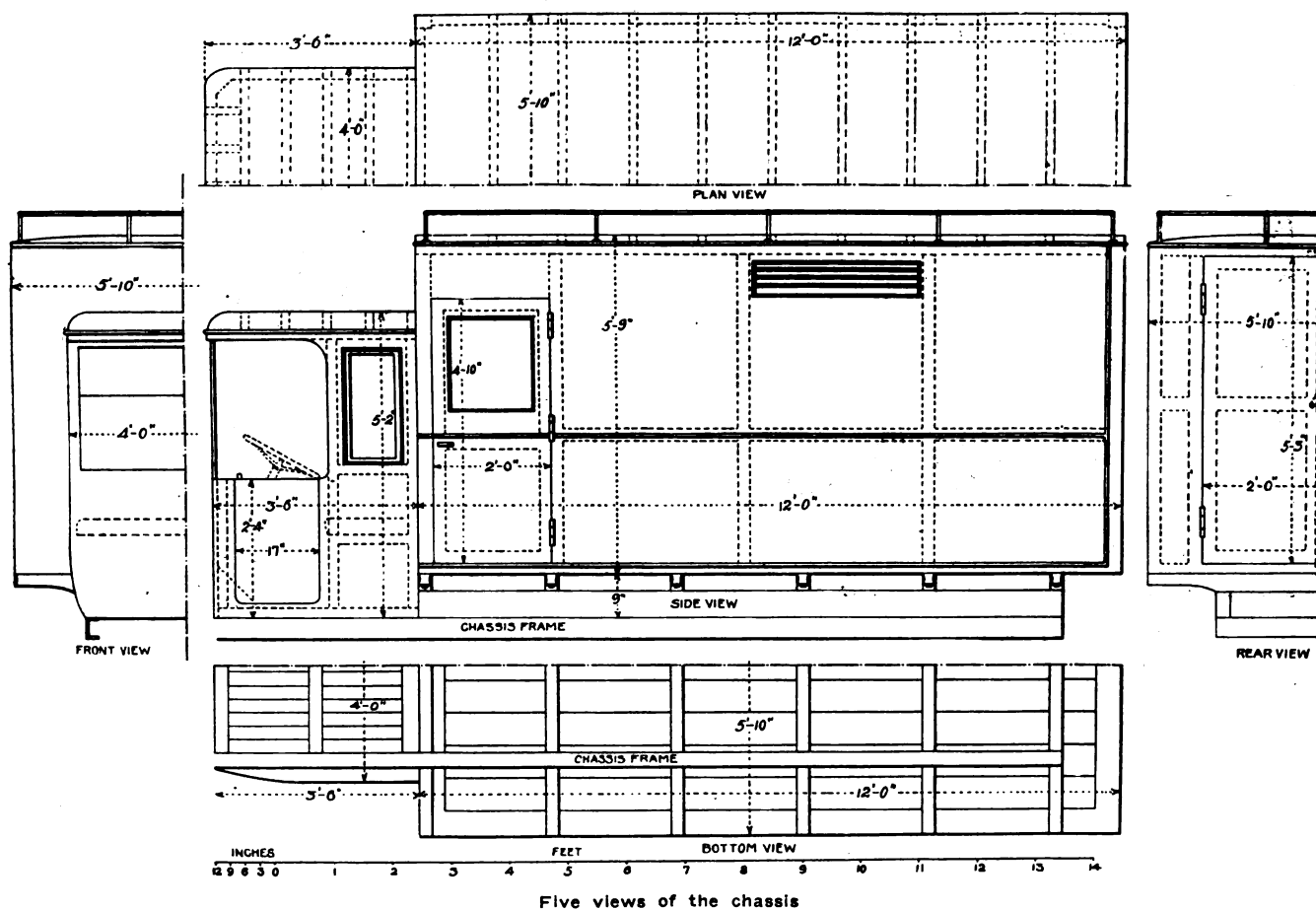

Five views of the chassis

with the chassis frame. To safeguard against mistakes, etc., the wheelwright should always get full particulars of the chassis, from the car itself, or from the engineer's blue print. The necessary measurements are as follows: Length from dash to rear of chassis, width of chassis, length from dash to center of rear wheels, height of chassis frame from the ground, width of dash and height of dash, wheelbase, track of wheels.

In the type of van shown in the illustrations, taken from the Blacksmith and Wheelwright, the cab is built independently of the main body and bolted to the chassis frame, so it can be easily removed if necessary. The body is raised 9 in. from the chassis in order to give wheel clearance, therefore doing away with the construction of a wheel house in the body flooring which is more expensive and interferes with the loading space of the van.

### Mott Wheel Works to Move to Jackson

The Mott Wheel Works, Utica, N. Y., is to be moved to Jackson, Mich., thereby concentrating the interests of O. W. Mott in that city, where his Jackson Rim Co. and Jackson Welding Co. are located. Jackson citizens subscribed for \$50,000 worth of Mott Wheel Works stock in order to secure the factory, which Mott had offered to move if local interests would take an interest in the company.

### Ford Buys Pig Iron for 1918

The Ford Motor Co., Detroit, has bought 40,000 tons of pig iron, for delivery in the first half of 1918, at a price of about \$34 a ton at the furnaces. It is stated that the company is in the market for about 10,000 tons more.



### Joseph N. Smith & Co. Plant

The accompanying illustration shows the new factory of Joseph N. Smith & Co., located at East Grand boulevard and DuBois street, Detroit, Mich.

The plant comprises over 77,000 sq. ft. of floor space; the buildings are so constructed as to give the best possible facilities for manufacturing the line of automobile body hardware which this company produces.

The buildings have been arranged to give every unit and department of the complete factory organization an individual space, so arranged that they co-operate with each other in the best possible manner for the least handling of goods from the time the raw material enters the factory until the finished unit reaches the shipping department for going forward to customers.

The works comprise a complete brass foundry, japanning, tumbling, polishing, grinding, heat-treating, press, windshield, plating and molding departments, tool room,

which Daniel T. Wilson is chairman, have been added Charles Clifton, president of the Pierce-Arrow Motor Car Co.; H. H. Rice, treasurer of the General Motors Co., and Alfred Reeves, general manager of the N. A. C. C.

The present headquarters are in the Mechanics' Institute, 20 West 44th street, where additional room is to be obtained so as to permit a greater number of pupils in the day and evening classes and also permit of doubling the size of the correspondence class. The day and night schools are free to all employes of automobile or body manufacturing plants and graduates are in constant demand by companies throughout the country. A small fee is asked for the correspondence course.

The pupils are divided into three distinct classes, namely, the introductory or free hand class, class for study of descriptive geometry, and class for scale and full size working drawings.

It is felt that the school is of vital benefit to the trade

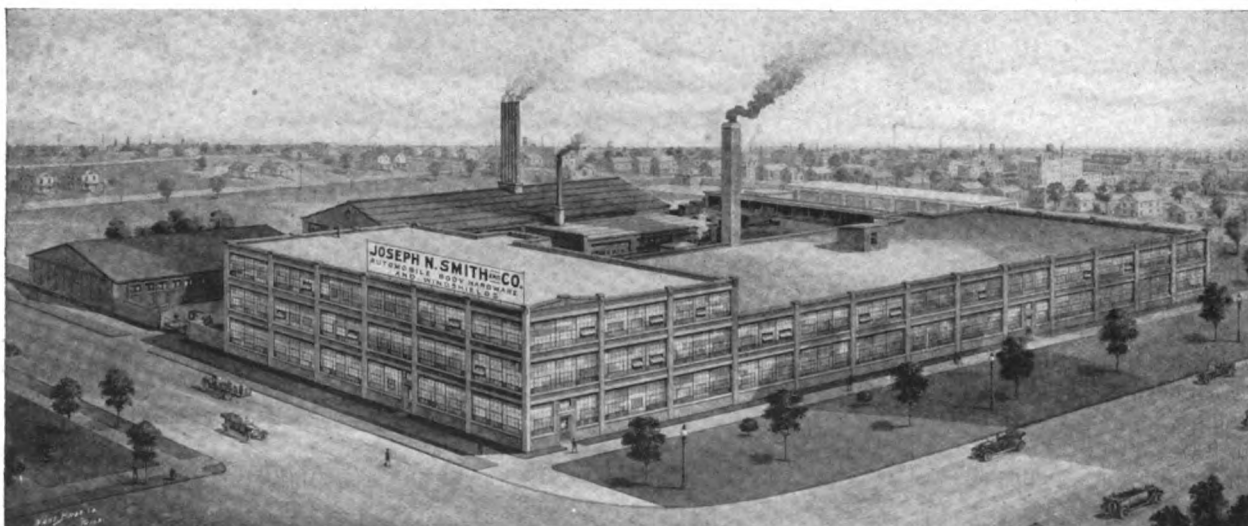

machine room, assembly room, together with spacious stock warehouses and shipping room.

The company has been employing at its old factory 350 people, and the new plant offers an opportunity for more than doubling its output.

The business was founded in 1875 by Joseph N. Smith and was run as a personal venture until incorporated in 1899 at \$25,000 capital; in 1905 this amount was increased to \$100,000, and in 1917 to \$500,000.

The officers of the company are: E. L. Ackerman, president and general manager; James Shand, vice-president; C. F. Blaesser, secretary and treasurer; C. E. Chamberlin, factory manager; C. T. Fezzey, sales manager; A. MacCorquodale, purchasing agent; G. S. Decker, superintendent.

### N. A. C. C. Takes Charge of Technical School

After having co-operated for the last few years with the Carriage Builders' National Association in the maintenance of the Technical School for Automobile Draftsmen and Mechanics, the directors of the National Automobile Chamber of Commerce have voted to take the institution in charge and broaden its scope to the end that more and better draftsmen can be supplied for automobile body manufacturers, now such an important part of the industry.

To the original committee in charge of the work, of

and warrants the support of the automobile manufacturers, who are arranging for additional equipment and the larger quarters offered by the Mechanics' Institute.

The day and evening classes and the correspondence classes are in charge of Andrew F. Johnson, who has been instructor of the school for more than 25 years and who is familiar with the need of not alone individually designed bodies, but of bodies for quantity manufacturers.

### Indianapolis 1917 Races Abandoned

No race will be run on the Indianapolis Speedway this year, for the annual May 30 event has been called off. James A. Allison, secretary and treasurer of the speedway, on March 24 notified all the racing drivers who had entered the contest that it had been decided not to conduct it in view of the military situation—which is not alone in its effect on Indianapolis sports.

### A. A. A. to Move to New Quarters

The American Automobile Association, which has been located at 437 Fifth avenue, New York, will move April 21 to 501 Fifth avenue. The new location is on the corner of Fifth avenue and Forty-second street, the new building of the Astor Trust Building, not yet completed, and one of the best corners in the city. The headquarters of the Contest Board will also be located at this address.

## Paint Shop

### How Reds Should Be Used

There is a famine in red! It's a blessing! This rage for reds upon everything, regardless of harmony or appropriateness, arouses one's opposition. A monstrosity in Melbourne's streets just now is—a red ice wagon. A hot, fiery color, suggestive of the glare of—the place where painters never go. The only appropriate color, suggestive of coolness, is snow white, emblematic too, of purity. Colors each have some significance. Red, in the Bible, is the color of blood.—II Kings. In Shakespeare we read of "the red lattice," as the customary sign of an ale house—Henry IV. (Glass was too dear and too brittle for the kind of guests that frequented them.) White suggests the innocence of angels, whereas in Revelation we read of "a scarlet woman." Yellow suggests jealousy; black and mauve for mourning and purple (and fine linen) were the appropriate signs of wealth and nobility. Blue denotes constancy, true blue, and the best authorities declare that it, and not green, is the national color of Ireland.

#### Vermilion

Most red has no permanence. It lasts long enough for the rose of the red fruit, just for a while, but the only red of value is vermilion. It was known to the ancients. It (and red lead) have been found in color pots in the ruins of Greek and Roman cities. Vermilion undoubtedly needs special treatment. The fame of Rubens' red was earned through the artist's possession of a secret of mixing which is now a lost art.

Vermilion is used upon the receiving letter pillars of Melbourne. In less than a year they fade to a powdery puce; the bright red perishes. The G. P. O. red motor wagons have an impoverished pink appearance, except the back panels, which are just a dirty faded cream.

An undercoat too light, or colored with a vermilionette is not desirable. Deep Indian red flesh color should be used. If the flesh color is made light, the vermilion being a mercuric sulphide, is affected prejudicially. No quick red should be used, and no varnish color. But two coats of red for bodies, kept back with a spot of oil and finished with two coats of clear varnish. Vehicles kept varnished have remained bright and red for 20 years done that way. Chinese vermilion was always regarded as the best. It was sold in 1 oz. papers.

Never mix varnishes and vermilionettes. There is a chemical reason. Very few are using vermilion since the war; even common reds are unprofitable, if not unprofitable. Color makers say naively on their circulars that their special "cheap red" is "as good as some customers desire." I might add that is—no good. They bleed like a cut finger. They stain the white that is painted on top. Indeed, all red painting jobs are a signal for danger; there are many "signal" reds. When sign writers find the color disappears from the red initials of a line of black lettering they often find the customer's name disappears from their books.

### Lakes

The "lakes" from tar products are also fugitive. Lake is the English rendering of the Italian word "lacca," a scum. Italian artists noticed the scum on the baths of dye in which dyed goods were boiled. They tried it with success as a paint. These dyes are now thrown upon a basis of whiting or gypsum as a carrier to make a paste, to thin as paint.

True carmine lake is made from crushing the cochineal insects in many thousands to obtain a very small quantity of red color. Yellow lake, better known as Dutch pink, is made from quercitron bark. Some purple lakes have vegetable origin—Brazil wood, log wood, etc. The coal tar colors, of which the first found were magenta, violet, and mauve (Perkin, 1856). M. Verguin transformed aniline into red in 1858. It was as early as 1825 that Faraday first distilled the naphtha from the coal tar. Mansfield, of York, was burned to death by the boiling water of a benzine still, while in pursuit of the color secret that when iodine is dissolved in benzine and distilled it produces violet. Tuscan red is Indian red mixed with dry whiting in equal quantities, and it is then dyed with rose pink. In the composition of many vermilionettes and royal reds, soda and alum are used.

#### Reds That Bleed

The "bleeding" can be overcome. But in estimating for changing the color of an old red shop front, or red motor to white or cream, be careful to allow for the extra work involved. One remedy is to apply an isolating coat of varnish before applying the white. A country motor painter was known to put eight coats of white each time thinking to obliterate the pinkish stain and then he failed.

Another remedy is to sponge the job over, and water tool the corners well with the following solution: Take two separate gallons of hot water. Dissolve 1 lb. of alum in one and 1 lb. of white copperas in the other. Mix both solutions together and apply. When dry, paint white, and it will keep white.

Yellow lining on reds detract from their richness and depth. The best relief is two strong parallel lines of rich blue, with a fine line of gold between them. For a very rich, yet quiet finish, a strong line with a fine line of black looks very well.

#### Water in Wagon Red

This wrinkle for wagon painters may be known to some. Add water in mixing. It prevents the heavy color settling to the bottom. In painting an undercarriage and wheels, painters usually find the bottom part of the paint too thick to spread, and the top part too thin to cover, unless they keep on stirring, which means delay. Put the non-fading red, Persian or Chinese red, into the pot dry. Then add water very gradually until it forms a paste; then add gold size to bind it till it is thick paint; then thin out with turpentine.—J. C. Harvie, in Australasian Coachbuilder and Wheelwright.

## Substitutes for Glue

A special committee of the American Chemical Society has just completed a survey of glue production and finds that with the cost of all animal products at a higher level than they have ever been in this country, glues have kept pace with the cost of all products in the field. Animal glues have more than doubled in price in two years, and, while this extreme condition is brought about entirely by the European war, due to the present condition of supply and demand, it is reasonable to expect, the report says, that in normal times animal glues will have a relatively higher cost value than ever before.

In view of the ever-increasing cost of all glue stock and the consequent higher cost of animal glues year after year, manufacturers have seen the opportunities for developing glue substitutes, the committee states. Glue substitutes are not new, but the use and application of them is not generally known and has only recently been developed commercially. Today glue substitutes are successfully used almost entirely in a wide range of industries, a brief description of which follows: in the manufacture of wall paper, for clay and ground work, for top printing and the like; in paper box manufacture; on the stripping and covering machines; for all solid box work; on folding and corrugated boxes, for all hand and automatic machine work, for trunk and bag work, for drawing on canvas, leather pasting, etc.; for textiles, such as warps, and all light and heavy sizing and finishing where formerly hot animal glue was necessary; for all book-binding work, for use on the entire book except the backing.

While the substitutes for animal glues cannot as yet be used for every purpose, they are nevertheless being successfully employed in increasing amounts each year, where they are entirely supplanting the much higher-priced animal product, the report concludes.

## DuPont Buys Harrison Paint Works

At a recent meeting of the stockholders of the Harrison Bros. & Co., Inc., of Philadelphia, the stockholders agreed to accept the offer made by the DuPont Company, of Wilmington, Del., and the paint firm became one of the DuPont's subsidiaries.

The sale marks the union of two of the oldest and best known manufacturing firms in the country. The Harrisons date from 1793 and the DuPonts from 1802. The transfer to new owners will bring no radical change in the conduct of the paint business. This will be continued by the new owners and the products hitherto turned out by the Harrisons will continue to be made by virtually the same organization.

Expansion is expected in the manufacture of paints colors, varnishes and pigments as well as chemicals, for the DuPont interests will bring to the new organization resources and experience that will increase the efficiency of the paints.

The paint and varnish business is no new industry for the DuPont organization. It already manufactures, and has on the market, a number of enamels, lacquers and similar articles. It also manufactures very large quantities of the basic materials used in the manufacture of paints and dyes. Benzol, wood oil, fusel oil, naphtha, ethyl and a great many other products have been produced by the DuPont plants and have been on the market for a long time.

The present Harrison plant on Gray's Ferry road, on the Schuylkill River, covers 40 acres, on which there are 80 buildings. Notable among these is a model lead plant with annual capacity of 10,000 tons. The demand for chemicals since the war has caused the company to organize the Mantua Chemical Co., whose works are at Paulsboro, N. J., on a tract of 250 acres, through which flows Mantua Creek, giving access to the Delaware River. The company also owns a plant at Sixth and Jackson streets, Camden, N. J.; and a pyrites mine in Virginia.

The price paid by the DuPonts is \$5,700,000 in cash, the purchasers assuming all the outstanding obligations of the company.

The business will be conducted by a new Pennsylvania corporation to be known as Harrisons, Inc., a charter for which has been applied for. The incorporators are Lam-mot DuPont, Dr. Charles L. Reese, and Charles A. Meade, of the DuPont Company; A. R. Glancy and Wm. Richter, secretary of the Harrison Company.

## Adjusts Differences on Varnish Drying Patents

Patent differences on the use of heated and moistened air in the drying of varnish on automobile bodies and other articles, has been adjusted between the Wenborne-Karpen Dryer Co., Chicago, and the Standard Varnish Works, New York, whereby the latter becomes a licensee under the Wenborne-Karpen company's patents. The process covered is largely used in the automobile industry in facilitating the finishing of varnished body jobs. Several car manufacturers, among them the Packard Motor Car Co. and the Cadillac Motor Car Co., both of Detroit, are already licensees.

Varnish possesses the peculiar property of drying quickest when in air that not only is warm, but is moist, and the Wenborne-Karpen company claims that its patents basically cover not only the apparatus but the process itself, now almost universally used in the quick drying of varnish and other siccative coatings. The claim is that the patents cover any process in which these finishing materials are dried by means of heated and moistened air, regardless of the apparatus used for heating and moistening. No attempt is to be made, however, to render this an exclusive method, the company stating that it will continue to make rights under the patents available to everybody, on payment of a moderate license fee.

## Dey Electric to Be Built at York, Pa.

J. W. Guthrie and H. W. Hayden are preparing a factory at York, Pa., for the manufacture of the Dey electric car. This car, which will be fitted with the patented axle and motor system invented by D. Steinmetz, of the General Electric Co., it is understood, will be the lowest priced electric car on the market. The makers expect to have the car on the market late in the spring.

## New York Police Department Adds Electrics

The New York Police Department, guarding against possible shortage of patrol wagons should the government call for gasoline vehicles, has added four electric patrols to its service. The cars used have shown their ability to do better than 100 miles a day under pressure, and the first one of this description owned by the city is still in use after ten years of service.

### The American Six

The American six, made by the American Motors Corp., Plainfield, N. J., is a car of strong distinctiveness produced under the supervision of Louis Chevrolet. As a driver of many years' standing, Chevrolet is well able to appreciate the many things that go to providing the owner of a car with real contentment; he knows just what gives annoyance when neglected, and the car itself is proof of the extreme practicalness of its engineer.

The price of \$1,285 is sufficient to enable great care to be given to detail in addition to providing the best of main chassis units; it permits the body to be nicely furnished, well upholstered, and thoroughly comfortable; most of all, it allows the engineers to make their own designs wherever they feel that they cannot purchase a stock article as good as they could make it.

As an example, the engine is specially designed for the car, though the gearset and the axles are stock products. The frame is one of the strongest and most rigid of any car in its class, and all the brackets, spring hangers, etc., are secured with particular care. It is a car which ought never to rattle or squeak and should be almost as good after a year's hard use as when it was first turned out of the factory. Weight has been studied also, and it is stated that the finished car is very light for its power.

The engine has the popular dimensions of 3 x 5 in., and is an L-head type without a detachable head, there being large valve caps, those over each exhaust valve having a substantial priming cock. As an example of detail, it is noteworthy that the cylinder which carries the pressure connection for the Carter fuel feed has a tee fitted in the valve cap so that the advantage of a cock is not lost even on one cylinder. The accessories, such as the Gray & Davis generator, ignition unit and starter, are grouped around the cylinders with due regard for their accessibility, the Zenith carburetor bolts right against the cylinders, the gland of the water pump and the fan belt adjustment are all within easy reach after lifting the hood.

Regarding the water pump, this delivers to the front end of the cylinders, and one of the clever ways in which weight has been saved is here apparent. Saving weight is largely a matter of making one part do the work of two, so the water pipe which conducts the cooling fluid

from the pump to the cylinders is a casting which also serves to carry the fan spindle.

The cylinders are all one casting, but this does not include any part of the crankcase, the latter being all of aluminum, for lightness sake. Platforms of aluminum carry the electrical units, the Gray & Davis timer being combined with the generator and the coil unit set alongside it. The starting motor is also on a platform, where it is well out of the water and dirt which would reach it in a lower position. The electrical accessories are so

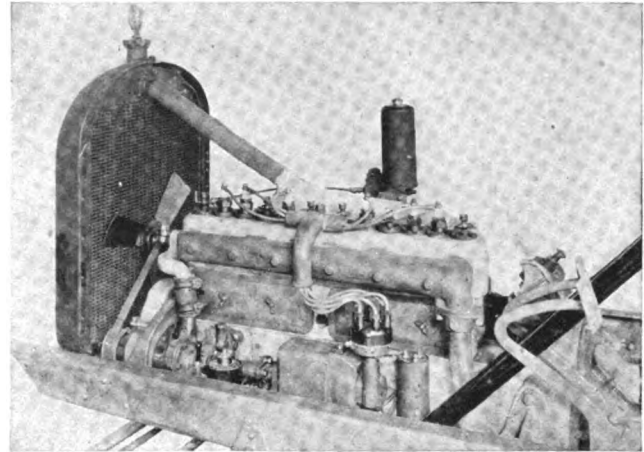

American Power Plant

mounted that they do not interfere with the accessibility of the valve tappets, which are easily got at by removing pressed steel covers.

The Borg & Beck dry disc clutch is used and this has multiplying levers incorporated within it, so that a very light pedal pressure is enough to release; at a guess, the pressure is between 30 and 40 pounds only, and any woman could operate the clutch without the least difficulty. The accelerator pedal also has an easy action, and the gear-shift lever is brought to a position within a natural grasping reach, so that changing from one gear to another is about as easy as it could be. The brake lever is placed far enough from the gear lever to prevent any possibility of a mistake, but near enough to be within equally easy reach.

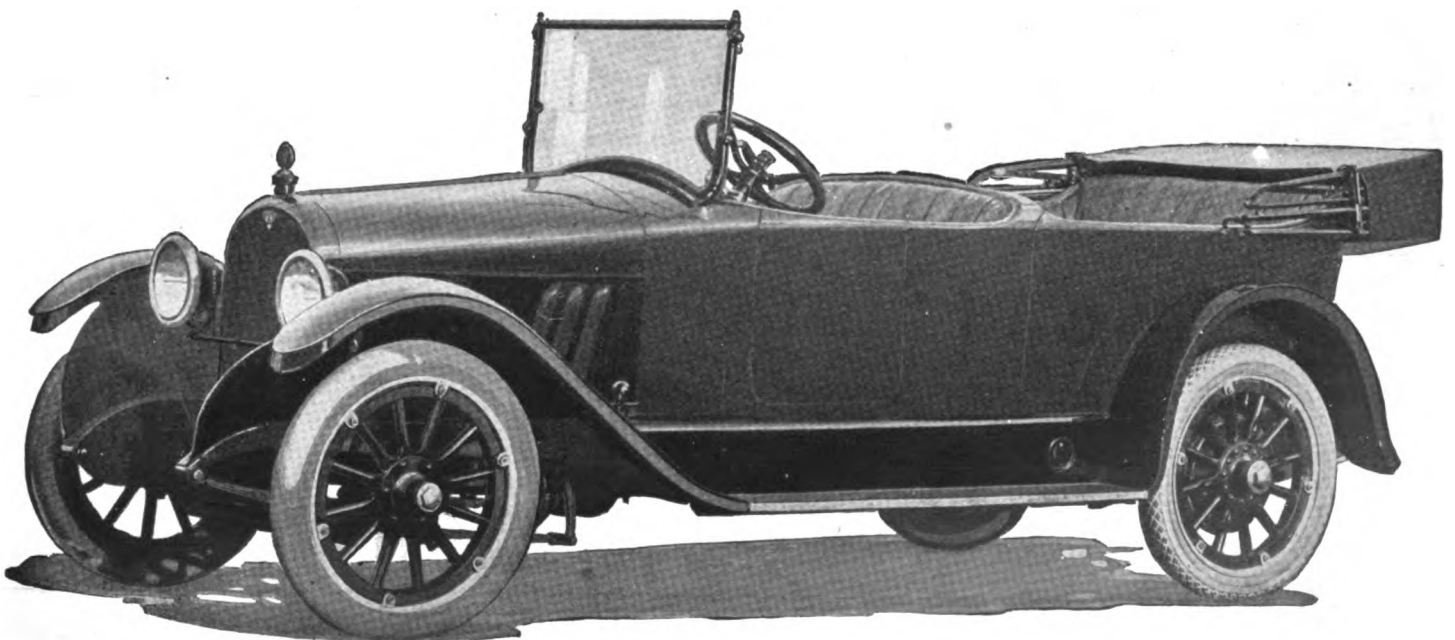

Gear 4 5/12 to 1 on high the American six is able to tackle most road conditions on high, but the facile gear-shift is a great advantage when an exceptional grade is encountered. There are, of course, three speeds, and the gearset itself is very compact, being as light as possibly consistent with ample strength. Back of the gearset there is a tubular propeller shaft with two universals carrying the drive to the Salsbury rear axle, upon which the brake equalizers are mounted, this again eliminating an assembly which would otherwise have to go upon the frame as a separate part. From the hand brake lever a single, straight rod goes right to the back axle without any other frame attachments, from the brake pedal there is a rod to a swinging lever depending from a cross member, and then another rod to the axle, the reason for using the lever hung from the frame being to give the brake a smoother action, as Hotchkiss drive requires the brake rod to be pivoted at the proper place.

The rear springs are semi-elliptic, of ample length and width to give easy riding, and they are underhung, passing beneath the rear axle. For steering, ease of action has been obtained in two ways. First, the front axle is set

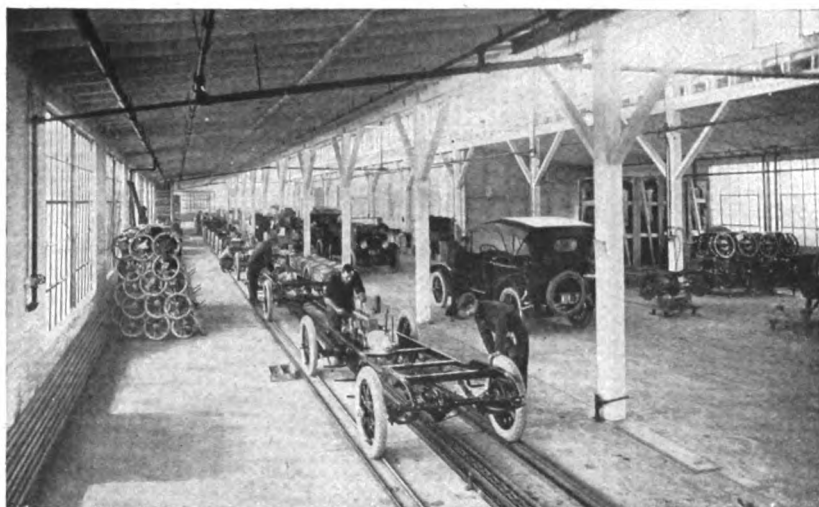

American Motors Progressive Production

on the springs at an angle, providing a natural casting action which is just enough to give a "feel" to the wheel, and, second, the steering gear itself, a Lavigne, is well provided with antifriction bearings.

Having a 122 in. wheelbase, there is plenty of room for the five-passenger body, which is the standard type and the only one that will be made at present. It is upholstered in leather and finished in dark blue. There is a good deal of polished woodwork, notably on the cowl board and back of the center cowl. Upholstery material and stuffing have not been skimped, with the result that very comfortable seating is provided.

On the cowl board all the instruments have been grouped together in a single assembly, the speedometer, ammeter, etc., all being in one unit. In connection with this there appears one of the little details that typify the car. It is well known that on most cars the position of the fuses which protect the battery is somewhat obscure. The American six has one main fuse protecting all circuits, the lamps, the ignition, and the horn, and this fuse sets in little clips above the speedometer dial on the cowl board plate. This means that should it blow, a new one can be slipped in instantly, without anything to undo.

Also the fuse makes a safety switch, since the driver can pull it out and put it in his pocket on leaving the car, and then no electricity can be drawn from the battery for any purpose.

Equipment includes 32 x 4 in. tires, a spare rim, mounted on a particularly stiff rear carrier, and all the usual accessories.

Dealers who are thinking of making a change in their agency arrangements will do well to write the American Motors Corporation, 141 Broadway, New York City.

## Goodyear to Build Large Hall for Employees

The announcement of a \$450,000 building, to be known as Goodyear Hall, in which to house the rapidly increasing educational, social and athletic activities of the Goodyear Tire and Rubber Co., Akron, O., has just been made by the directors of the company.

The company believes that workmen, as a rule, are better off if they remain associated with one organization than if they should constantly change positions from one company to another. So the prime reason for the new hall is the desire to offer to all employees the greatest facilities for their mental, physical and social betterment, and at the same time cement their relations to the company.

One of its promising features is an immense gymnasium for all kinds of indoor athletics requiring a large assembly hall. It is to have a seating capacity of 5,000, with all stage and assembly hall facilities. Adjoining will be a swimming pool ranking in every respect with the best in the country.

Another feature is an auditorium with a seating capacity of 1,400, arranged with particular reference to acoustic properties, to be used for sales and factory conferences, theatricals and entertainments.

Provision has also been made for the housing of the company's factory school and the offices of the numerous Goodyear societies. In the basement there are to be installed bowling alleys, shower baths, locker rooms, rifle range, checkrooms and handball courts.

The new Goodyear Hall is for the use of all employees—in factory, office and outside organization. Building operations are to begin immediately and pushed to an early consummation.

## S. A. E. Summer Meeting

The summer meeting of the Society of Automobile Engineers will be held the last week in June, 26-29, at Ottawa Beach Hotel, on Lake Michigan. Ottawa Beach Hotel is located on the east shore of Lake Michigan about 100 miles across the lake from Chicago. It is within six miles of Holland, Mich., and close to Grand Rapids.

With the society membership embracing three additional arms of the automotive industry it was necessary to secure larger accommodations than the boat afforded and also space where it would be possible to hold several sessions at the same time such as can only be done at a hotel given over exclusively to the engineers. Ottawa Beach will afford facilities for holding separate sessions when necessary for automobiles, trucks, aeroplanes, tractors and motor boats.



### How Truck Tire Equipment Is Selected

Tire equipment for trucks is largely made by advice of tire manufacturers after learning the weights of the machines and the capacity loads to be carried. This subject, says Motor Truck, is especially interesting to analyze because of the obvious difference in judgment as to what had best be used for trucks of varying capacities. To consider this briefly is really essential, and in this connection the following tabulation, which shows the maximum loads that ought to be carried in service by different sizes of tires is very interesting:

Width of tire in inches	Single Tires						Miles per hour
	Diameter of tire in inches						
2	32	34	36	38	40	42	20
2½	450	475	500	525	550	575	20
3	670	710	750	790	830	870	20
3½	900	950	1,000	1,050	1,100	1,150	20
4	1,130	1,190	1,250	1,310	1,370	1,430	18
5	1,350	1,425	1,500	1,575	1,650	1,725	16
6	1,800	1,900	2,000	2,100	2,200	2,300	14
7	2,250	2,375	2,500	2,625	2,750	2,875	12
8	2,700	2,850	3,000	3,150	3,300	3,450	10

Width of tire in inches	Dual Tires						Miles per hour
	Diameter of tire in inches						
2	32	34	36	38	40	42	18
2½	1,125	1,188	1,250	1,312	1,375	1,438	18
3	1,675	1,775	1,875	1,975	2,075	2,175	18
3½	2,250	2,375	2,500	2,625	2,750	2,875	16
4	2,825	2,975	3,125	3,275	3,425	3,575	14
5	3,375	3,560	3,750	3,940	4,125	4,310	13
6	4,500	4,750	5,000	5,250	5,500	5,750	12
7	5,625	5,940	6,250	6,565	6,875	7,190	10
8	6,750	7,125	7,500	7,875	8,250	8,625	10

As an illustration of tire equipment the truck specifications of 30 different manufacturers who build 2, 3½ and 5 ton trucks have been taken, and of these 30, 25 build two-ton trucks, 22 build 3½-ton trucks and 19 five-ton trucks. Of the two-ton machines seven have 34 x 4 in. single tire equipment for the forward wheels, and 17 use 36 x 4 in. single tires. Of this 25, 14 fit their trucks with 36 x 4 in. dual tires. The forward 24 x 4 in. single tires have a combined load capacity of 2,850 lbs.; the 36 x 4 in. single tires have a combined load capacity of 3,000 lbs.; the 36 x 4 in. dual tires have a combined load capacity of 7,500 lbs. The trucks having either equipment have a total load capacity of 10,350 or 10,500 lbs. Allowing 4,000 lbs. for the load this leaves 6,350 or 6,500 lbs. for the weight of the chassis and body, showing that while tires are ample for full loads there is but very little margin for excess freight.

#### Very Small Margins of Safety in Truck Tires

Of the 22 different makes of 3½-ton trucks, 20 of them have 36 x 5 in. single front wheel tires and 14 have 35 x 5 in. dual, and five have 40 x 5 in. dual rear wheel tires. Considering these from the same aspect the front tires have a combined load capacity of 4,000 lbs. and the rear tires have load capacities of 10,000 and 11,000 lbs. respectively. Thus the trucks have total load capacities of either 14,000 or 15,000 lbs., and allowing 7,000 lbs. for the rated load, this leaves 7,000 or 8,000 lbs. for the weight of the chassis and body. Here again is a comparatively small margin of safety for the tires.

Of the 19 manufacturers of five-ton trucks, eight install 36 x 5 in. single tires on the front wheels, and nine install 36 x 6 in. single tires. Eleven of the 19 use 40 x 6 in. dual tires on the rear wheels. The front tires of the trucks have either 4,000 or 5,000 lbs. load capacity, and the rear tires 13,750 load capacity, so that the total permissible weight on them by the tire ratings is either 17,750 or 18,750. With a rated load of 10,000 lbs., this allows 7,750 or 8,750 for the chassis and body. One will observe that there is even a smaller margin of safety for the tires.

The statements made are not reflections upon the manu-

facturers of the trucks, for the figures prove that they have made sufficient provision for the loads the machines are rated, but in no instance have they tired the wheels so generously that an owner is justified in carrying anything in excess of the normal freights. No claim is made that the loads must be exact, although there is little doubt that better results would obtain were the freights weighed. To better emphasize the figures that have been given they are tabulated in this manner:

Two-Ton Trucks—Front Tires					
34 x 3 1	34 x 4 7			36 x 4 17	
3½-Ton Trucks—Front Tires					
36 x 4 1	36 x 5 20			38 x 5 1	
Five-Ton Trucks—Front Tires					
36 x 5 9	36 x 6 8	38 x 5 1		38 x 6 1	
Two-Ton Trucks—Rear Tires					
34 x 3½D 3	34 x 4D 1	36 x 3½D 3	36 x 4D 14	36 x 6 2	36 x 7 2
3½-Ton Trucks—Rear Tires					
36 x 4D 2	35 x 5D 14	38 x 4D 1		40 x 5D 5	
Five-Ton Trucks—Rear Tires					
36 x 5D 2	36 x 6D 2	38 x 5D 1	40 x 6D 11	42 x 5D 1	40 x 5D 1

From examination of these tables one will find that there are equipments smaller and larger than those that have been stated as generally representing the industry. No average or standard equipment can be specified, but the statement can be accepted without question that the 30 different manufacturers whose machines are referred to in the above tabulations can be regarded as representative from every point of view.

No question can be raised as to the position of the tire manufacturers. They rate the tires they produce with reference to load and speed capacities, and they guarantee them fully. The tires will endure, and they will as a rule considerably exceed the guaranteed mileages if used with anything like reasonable care. But they are not designed to be overloaded, and the owner who sanctions overloading cannot complain if the tires wear quickly and are destroyed because they are worked beyond the capacities for which they were intended.

The statement may be interpolated here that with very rare exceptions do the owners require their drivers to carry normal loads. There is seemingly the belief that an excess of load is "cheating" the manufacturer of the tire, because of the guarantee. But there is no question that those who believe they are getting something for nothing are paying for everything they get.

### Improving the Sparton Horn

Col. Wm. Sparks, president of the Sparks-Withington Co., Jackson, Mich., has been giving attention to betterments in the Sparton horn, according to recent patents.

In one of the inventions provision is made for modifying the tone of the horn, either by an adjustment at the end of the motor shaft or by varying the position of the motor field. By this means the motorist may warn his friends and neighbors of his coming in high C, middle G, or otherwise, as suits his individual fancy. In another patented improvement the position of the motor with respect to the diaphragm is rendered adjustable without interfering with the action of the instrument, the purpose being to adapt the construction to such odd corners about the chassis as manufacturers sometimes select for the horn.

## Chauncey Thomas & Co.'s New Home

Chauncey Thomas & Co., who have been in business since 1862, being the first carriage builders in Boston, are now located in their new building in the heart of the automobile district, on Blandford street, between the two principal highways of Boston, Beacon street and Commonwealth avenue.

The building is four stories with concrete basement, and is fire proof, with sprinklers throughout. The basement is used for blacksmith and machine shops, also boiler room. On the first floor is the office, assembly rooms and storage for finished work. The second floor has the up-

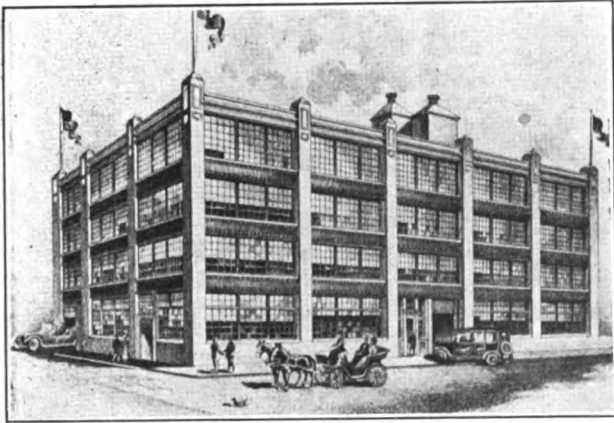

holstery and body building department. The third floor is used on one end for the aluminum metal workers' department. The balance of the floor is used for the paint shop, on one side of which there is a baking oven where all japanning is done. On the top floor are the finishing rooms.

A feature about the paint shop and its finishing rooms is the special ventilating apparatus to create a current of air so necessary in most paint departments. The entire plant is operated by electricity and each department is run by separate power which is a great saving over the method employed in the old factory at Chestnut street, and which was entirely destroyed by fire. A 25 ft. freight elevator and an electric A. B. C. passenger elevator for the convenience of customers has been installed.

O. H. Schildbach, a body builder of New York, and a graduate of the New York Technical School, has been vice-president of the corporation for ten years, and has been elected president since January 1 this year. The company enjoys the reputation of building the finest of custom work.

## Wire Wheel Corp. Buys Houk Co.

The Wire Wheel Corp., recently formed with \$2,000,000 capital by a syndicate in which Bertron, Griscom & Co. and Jamieson, Houston & Graham, Inc., were active, has purchased the entire Houk wire wheel interests, covering both the George W. Houk Co. and the Houk Wire Wheel Corp.

John F. Alvord, president of the Standard Co., Torrington, Conn., the Splittorf Electrical Co. and the Hendee Mfg. Co., heads the new concern, with George W. Houk and R. E. Griscom as vice-presidents, and S. A. Fahnestock, secretary and treasurer.

Negotiations, it is stated, are now under way with other wire wheel makers with a view to issuing licenses.

The East Springfield plant of the Hendee Mfg. Co.,

covering 10½ acres and 175,000 ft. of manufacturing floor space, has been acquired, and will produce wire wheels for high-priced cars and also develop wheels for low-priced cars.

The Houk plant at Buffalo will be increased in capacity by 100,000 sq. ft., work on the addition starting May 1, and the production of Houk wheels will be greatly increased.

## British Car Makers Want Protection

The British motor car manufacturers are not content to depend upon the patriotic spirit of the British subjects for patronage, but favor the protective tariff as the most efficient means of barring the American product after the war is over. The commandeering of the English motor car plants by the government has permitted American manufacturers to gain a strong foothold in the British Isles, as well as in the colonies, and the fear that they will become so firmly entrenched in these markets as to cripple the British motor industry has started agitation to secure some form of tariff protection to discriminate against the imported products.

## Wheel Tax on All Omaha Vehicles

A wheel tax designed to produce \$50,000 per year for repairing pavements, has been passed by the city council of Omaha, Neb., and is now in effect. The ordinance requires every vehicle using the public streets, whether horse-drawn or motor, to carry a city license. The fee is graded according to the horsepower of the vehicle. The tax on horse-drawn vehicles will run from \$1 to \$6 per year. That on automobiles will be from \$2 to \$12, and on trucks from \$4 to \$20. In case the manufacturer or dealer places no power rating on the car, the tax will be \$5 for cars and \$7 for trucks.

## To Secure Rubber Matting to Metal

Rubber matting may be secured to metal surfaces by using a cement made by dissolving flake shellac in alcohol to form a thick syrup. Several thin coats, carefully applied, should be given to each surface, and the first should not be allowed to get quite dry before another is applied. Press the rubber carefully upon the metal, and, by the use of a piece of board and rather heavy weights, keep the two surfaces pressed together for about 24 hours. Where linoleum is used as a floor covering for cars, a coating of linoleum cement applied once a week, or at slightly longer intervals, will ensure its practical indestructibility.

## Marlin Arms Buys Mayo Radiator Co.

Interests identical with the Marlin Arms Co. have completed the purchase of the Mayo Radiator Co., of New Haven, Conn., and will continue it as a separate concern and under its present name, but with greatly enlarged capital and other facilities. The same interests recently bought the Standard Roller Bearing Co. and the Rockwell-Drake Co.

## Dort Capital Trebled

The Dort Motor Car Co., Flint, Mich., has increased its capital stock to \$1,500,000. It was formerly capitalized for \$500,000.

### Gas Economizer and Carbon Remover

The Esta Water Auxiliator, gas economizer and carbon remover, is an automatic no-cost fuel device. The engine suction, causing a vacuum in the container, draws numerous currents of air through the water in the device, gener-



ating a completely humidified air or water vapor (not liquid water or steam) which is drawn into the intake manifold. It there combines with and completely vaporizes the gasoline, forming a damp-er mixture. This mixture is then introduced into the combustion chambers, where the water vapor is converted into live steam on the ignition stroke, insuring a more powerful and sustained power stroke, an additional supply of oxygen, complete combustion of gasoline and automatic elimination of carbon. In brief, this device, by introducing a humidity or water vapor into the motor duplicates the conditions of a damp day. By generating a live steam in the motor after the ignition stroke, it decomposes and blows out the carbon while the car is running. It is manufactured by the Esta Water Auxiliator Co., 1916 Broadway, New York.

### Plan Big Addition to Quartermaster's Auto Plant

A great automobile plant will be established in connection with the Jeffersonville, Ind., quartermaster's depot if Congress grants an appropriation of \$100,000 which has been requested. The money is needed for additions to the present plant, ample land being available. The plant is intended to take care of the great number of motor trucks which the army will need, building of bodies and, if necessary, of complete trucks. It is also to be used for the repair of trucks sent in from the field.

### C. P. Winslow a Director of Forest Products Laboratory

Announcement is made by the Forest Service of the appointment of Carlile P. Winslow as director of the Forest Products Laboratory, at Madison, Wis., to succeed Howard F. Weiss, whose resignation takes place April 1.

Mr. Winslow was graduated from the Sheffield Scientific School of Yale University in 1905, and entered the Forest Service in 1908. He is an expert on wood preservatives and has done considerable research work on this and allied lines.

### Kansas City Convention Dates

For the twenty-ninth time Kansas City was chosen as the meeting place for the Western Retail Implement, Vehicle and Hardware Association. The action was taken by the directors and the date was set for January 15, 16 and 17, 1918. A committee was named, consisting of representatives from Kansas, Missouri and Oklahoma to confer with the agricultural colleges regarding expansion work.

### J. M. Studebaker, Jr., Succeeds Father

At the annual directors' meeting of the Studebaker Corporation held in New York, April 3, J. M. Studebaker, Jr., was elected a director, to succeed his father, J. M. Studebaker, Sr., deceased.

The board organized for the coming year with the same officers. The office of honorary president, which had been held by J. M. Studebaker, Sr., was left unfilled. The finance committee is composed of Messrs. Fish, Erskine, Hanch, Heaslet, and G. M. Studebaker. The executive committee is composed of Messrs. Fish, Delafield, Erskine, Goldman, Lehman, and G. M. Studebaker.

### Wage Increases to Steel Workers

During the past 15 months the United States Steel Co. has increased by 46 per cent the wages of its men who receive below \$2,500 a year. Four times in that period the company has made an increase of 10 per cent. The latest has just been announced and will take effect May 1, when the workers will be receiving 46 per cent more than they did only 15 months before. The increases were voluntarily made to keep step with the rising cost of living as shown by the studies of the company.

### Staggered Door in Willys-Knight Sedan

The Willys-Overland Co., Toledo, O., is now building a staggered-door type of convertible sedan body on its Willys-Knight Four chassis to sell at \$1,950. The doors are placed so that passengers enter in the middle of the car giving unobstructed passage to seats, while the driver's door is at the front on the left side, allowing him to enter or leave without interfering with others in the car. Up to this time the convertible sedans were equipped with doors on each side in the middle of the car.

### N. A. C. C. Men on Industrial Board

Charles Clifton, president of the National Automobile Chamber of Commerce, and John Willys have become representatives of the N. A. C. C. on the National Industrial Conference Board, which is composed of national organizations of manufacturers for the consideration of matters affecting industrial development. This body has also been organized with a view to presenting to the public and legislative bodies the business man's side of important questions.

### Harry Tipper to Manage The Automobile

Harry Tipper, for nine years advertising manager of the Texas Co., has resigned to become manager of The Automobile, which position he assumes May 1. At the present time, in addition to having charge of the advertising department of the Texas Co., which he created nine years ago. Mr. Tipper is president of the Advertising Club of New York City and is a past president of the Association of National Advertisers.

### Fageol Cars Temporarily Withdrawn

Owing to heavy government requirements for the Hall-Scott aviation engine, the Fageol Motors Co., of Oakland, Cal., has withdrawn from present activity and will make no deliveries until a more favorable opportunity.





Fourth Annual Entertainment, Sheldon Relief Association, at Y. M. C. A. Hall, Wilkes-Barre, Pa.

### Sheldon Relief Association's Annual Entertainment

The fourth annual entertainment and social of the Sheldon Relief Association was held Saturday night, March 24, at the Y. M. C. A., Wilkes-Barre, Pa., about 1,700 of the employees and members of their families attending. J. Fred Armstrong, secretary of the company presided as chairman of the meeting, and delivered the address of welcome to the employees and the members of their families.

L. M. Holdsworth, president of the Sheldon Relief Association, read the annual report of the association, which showed the finances to be in a very prosperous condition.

Thomas H. Atherton, president of the company, made an address in which he expressed his admiration for "men who do things," as he termed the producers. He dwelt upon the necessity for mutual helpfulness which makes for mutual dependence in industrial and other branches of our national life.

George M. Wall, vice-president and general manager of the company, in his address, reminded the employees of their tasks in the event of war and pointed out that the industrial workers of the nation would play a large part in carrying on the war to a successful termination. He said that honor and glory in war times are not alone for him who shoulders arms and marches away, but also for the workers producing the sinews of war.

Oppenheim's orchestra of ten pieces furnished music, and William J. Delaney led the assemblage in singing the Star Spangled Banner. An excellent program of entertainment was presented by Miss Nora Lowery, Calvin M. Davis, Aloysius Kane, James Evers, Edgar Edwards and

Thomas Collins. A feature of the entertainment was a demonstration by the Sheldon First Aid team of which the following are members: Richard Jordan, captain; Geo. Marshall, subject; Alex Rowe, Frank Robinson, Geo. Hemstreet, Thos. Crowe, Ernest Cary, and Robert McCutcheon.

The committees in charge had as members the following: Howard Davis, William Delaney, John Marshall, Patrick O'Day, Harry Leavy and George Hemstreet.

Motion pictures and refreshments followed the entertainment.

### Wants Low-Priced Cars Manufactured

The Manufacturers' League of America, Inc., 116 Broad street, New York City, is looking for a manufacturer who will turn out low-priced cars for the export trade. Marco Aurelio Herradora, general manager of the company, states that the machine should cost between \$300 and \$400 and that an initial order for from 50 to 100 cars would be placed. The company has numerous branches in Central and South America and Spain, and would sell the car under its own name.

### Autos in Transit Need No License

The French government has decided that it will not be necessary to obtain a French import license in the case of goods specified in the list of prohibited imports, when such articles are to pass in transit through France, either by parcel post or otherwise, or are to be transhipped in a French port en route to some other country. This concession is not extended, however, to articles that are to be warehoused in France.

# Vehicle Industry News in Brief

## Truck Builders

Commerce Motor Car Co., Detroit, has raised the prices of its standard models \$100.

Union Motor Truck Co., Bay City, Mich., has increased its capital from \$15,000 to \$30,000.

Republic Motor Truck Co., Alma, Mich., has increased its capital from \$1,312,500 to \$1,500,000.

Biggam Trailer Corp. has purchased a factory building at Owosso, Mich., and will manufacture automobile trailers.

Menominee (Mich.) Motor Truck Co. is preparing to build additions to its plant in order to handle increasing business.

Duplex Truck Co., Lansing, Mich., will build a plant to cost \$1,000,000 on a 15-acre tract. The first unit will be 600 ft. long.

Niles (O.) Car & Mfg. Co., making motor trucks and cars for electric railways, has decided to discontinue the manufacture of motor trucks.

E. T. Ross, of the Ross Engineering Co., Detroit, will manufacture a light truck and has asked for bids on parts and materials for 50,000 trucks.

Moreland Motor Truck Co., Los Angeles, Cal., has closed negotiations for the purchase of a site on San Fernando road, Burbank, for the erection of a new plant.

Stegeman Motor Car Co., Milwaukee, Wis., will have 50,000 sq. ft. of floor space when plant additions now in the course of construction are completed, and will increase its production of trucks.

Commerce Motor Car Co., Detroit, manufacturer of motor trucks, will build another addition, four stories, 100 x 300 ft., which will adjoin its factory buildings at Solvay and Mackie streets.

Redden Motor Truck Co., Inc., has combined its New York and Detroit offices with its new Chicago office. Temporary headquarters have been established at 1442 S. Michigan avenue, Chicago.

Motor Vehicles of Montreal, Ltd., Montreal, has been incorporated with a capital stock of \$20,000, by O. Le-grand, G. Demers, L. E. Beaugard, and others, to manufacture motor trucks, automobiles, etc.

Equipment Motor Truck Co., St. Louis, Mo., has been incorporated with a capital stock of \$50,000, by H. J. Dunker, S. M. Laithe and W. A. Yackey, Jr., to manufacture and repair motors and motor trucks.

Glen Motor Truck & Trailer Co., New York, automobiles, trucks, trailers and tractors, incorporated with a capital of \$3,000,000. The incorporators are: A. W. Britton, H. B. Davis, S. B. Howard, New York.

Signal Motor Truck Co. of Canada, Ltd., Toronto, has been incorporated, with a capital stock of \$50,000, by John S. McLaughlin, 18 Oriole Gardens; Frederick E. Earl, 262 Sherbourne street; James McFadden, and others.

H. J. Koehler Motors Co., Newark, N. J., has brought out a new model styled K-1¼, which will supplant the model K 1-ton truck. Between 2,000 and 3,000 trucks will be produced by January 1, 1918. Deliveries are now being made.

Kardell Tractor & Truck Co., St. Louis, Mo., has been incorporated in Delaware with a capital of \$1,000,000, to manufacture trucks, plows and kindred machinery. H. W. Kardell, J. C. Kardell and H. F. Fahrenkrog, St. Louis, are the incorporators.

Miller Auto Sales Co., Grand Rapids, Mich., has been organized to manufacture a truck to be called the Milton. W. C. Miller is president and general sales manager of the company, L. W. Coppeck, vice-president, and L. A. Corcora, secretary and treasurer.

Krebs Commercial Car Co., Clyde, O., has been sold to Massachusetts capitalists, including C. R. Dunbar, of Holyoke; C. H. Bowker, of Northampton; W. P. Dodge, of South Lea, and J. B. Crockett, of New York. Louis Krebs and Harmon Baynes retain their interests.

F. D. Truck & Auto Co. has been formed at Adrian, Mich. It is the successor to the Forduplex Co. The Duplex Motor Co., of Lansing, Mich., objected to the use of the latter name although the Ford Motor Co. had given its permission. The company is looking for a factory site.

United States Motor Truck Co., Cincinnati, O., has received a running order for 20 five-ton trucks a month, delivery commencing at once, the trucks to be used in France by Parisian merchants whose vehicles have been commandeered by the French government for war purposes.

Pull More Motor Co., New Castle, Pa., is to be reorganized with \$10,000,000 capital stock. Money secured by sale of new stock will be used to finance the large plant now building, which is to be ready for use by June 1 and will greatly increase the production of the Pull More truck.

Dodge Brothers, of Detroit, have completed a few experimental models of the new light delivery car that they will manufacture on a large scale in the near future. The chassis is similar to Dodge stock touring car, only that they have heavier springs, oversized tires and a shroud flush with the windshield.

Famous Truck Co., Inc., St. Joseph, Mich., capitalized at more than \$2,000,000, will erect a plant at once to manufacture a light weight automobile delivery truck. The company is backed by the McIntyre Company, Ltd., Chicago. Clayton Frederickson is general manager. Machinery will be ordered immediately.

Federal Motor Truck Co., Detroit, will increase the prices of its standard models within the next 60 days. The 1½-ton truck, now \$1,800, will cost \$2,100, and the 3½-ton model, now \$2,800, will cost \$3,000. The company in the near future intends to bring out two new models—a 1-ton truck to cost \$1,650, and a 5-ton truck to cost \$4,000.

Racine Motor Truck Co., Racine, Wis., is being organ-

ized with a capital stock of \$500,000, to erect a plant to manufacture motor trucks, etc. Details are indefinite. Charles F. and Fred H. Piggins, who have been engaged in wagon, axle and spring manufacture at Racine for some time, and Ira Miller, Los Angeles, Cal., are promoting the enterprise.

Metropolitan Motors, Inc., New York City, W. C. Mack, president, has started production on its new truck, which will be known as the Mackbilt. Only one chassis size will be produced, having a wheelbase of 115 in., with a  $3\frac{3}{4} \times 4\frac{1}{4}$ , four-cylinder engine, bevel drive, gear ratio in high of six to one. Pneumatic tires are used all around,  $34 \times 4$  front and  $35 \times 4\frac{1}{2}$  rear. It will sell for \$895.

### Body Builders

Irvin Robbins & Co., Indianapolis, manufacturer of automobile bodies, has increased its capital stock from \$8,000 to \$100,000.

Sales and advertising headquarters of the Springfield Body Co. now are located in Detroit. The new plant there is now in full operation.

Highland Body Mfg. Co., Cincinnati, has increased its capital stock from \$81,000 to \$150,000, and will add to its capacity at an early date.

Lang Body Co., Cleveland, O., capital \$500,000, has been incorporated by Elmer J. Lang, H. Price, John A. Alburn, Richard F. Edwards, and Cary R. Alburn.

Kelsey Wheel Co., Windsor, Ont., manufacturer of bodies and wheels for automobiles, is contemplating making additions to double its present capacity.

J. E. Brooks will have charge of sales for the Lehman Mfg. Co., Cannelton, Ind., manufacturer of Lamco speed bodies for Ford, Maxwell and Overland cars.

Gotham Auto Body & Painting Co., Inc., has been organized in New York City; capital, \$15,000. Incorporators: I. Gordon, P. R. DeBracke, F. Nuncie.

C. V. Hill Co., Trenton, N. J., will manufacture automobile delivery bodies. This company has been manufacturing since 1890, specializing in refrigerators, etc.

Hughes & Curren Co., Inc., has been organized at Rochester, N. Y., to manufacture auto bodies, capital \$3,000, by W. H. Emerson, A. H. Hughes and H. S. Curren.

The Blaser Body Co., Fostoria, O., capital \$50,000, has been incorporated by Julius Schindler, Fred Wilson, Peter J. Blaser, Henry Ockschim, Herbert Wilson and A. C. Dumont.

E. L. Smith, Alma, Mich., has purchased the building formerly used by the Deal Buggy Works, at Jonesville, Mich., and will manufacture auto truck bodies and other automobile accessories.

Locke & Co., 218 W. 84th street, New York, manufacturer of automobile bodies, has acquired property at 56th street and Avenue A for the erection of a four-story plant,  $65 \times 180$  ft., to cost \$100,000.

August Stedenfeld, 210 Camden street, Newark, N. J., has organized a company to operate a local plant for the manufacture of automobile and wagon bodies. William Stedenfeld also is promoting it.

The metal department of the Central Mfg. Co., Connersville, Ind., makers of bodies, was destroyed by fire

recently, causing a loss of \$150,000. William B. Ansted, president, said the plant will be rebuilt at once.

Bay City Auto Body Co., Bay City, Mich., has purchased a local plant formerly used for the manufacture of skewers, and will move into it shortly. There is a main building  $100 \times 125$  ft., a warehouse and storage sheds.

Field Mfg. Co., which makes automobile bodies in Ionia, Mich., has decided to move to Owosso. It will occupy the plant there formerly used by the Owosso Carriage & Sleigh Co., and will expand its output of bodies and parts.

C. R. Wilson Body Co., Detroit, has made arrangements for the construction of a plant in Bay City, Mich., having secured 43 acres of land. The new plant will be used for woodworking only, and will increase the company's floor space by about 160,000 sq. ft., giving a capacity of between 800 and 900 bodies daily. It is to be ready for use early in the summer.

Limousine Top Co., Lansing, Mich., has expanded for the second time within a month by the leasing of 33,000 sq. ft. of floor space in the plant of the States Motor Mfg. Co. The company is also adding an extension which will give the main plant a floor space of about 150,000 sq. ft. In two years the company has increased its capital from \$15,000 to \$500,000 and its business has expanded in proportion.

Darwin Hanauer, M. E., has become chief engineer of the Hal Motor Car Co., Cleveland. He will specialize in the designing of custom-built bodies. Mr. Hanauer formerly occupied a similar position with the Baker, R. & L. Co. and held the same position with the Daimler, Simplex and Palmer-Singer companies. He was one of the pioneer designers of modern types of roadster bodies, the disappearing top, and a few other innovations in body building.

The Brown Auto Carriage Co., at East 32d street and Superior avenue, Cleveland, O., is to increase its capital stock to \$750,000. It intends to build a body plant large enough to take care of the vast volume of business which has been going out of the city. The company was organized eight years ago and operated a small plant on the West Side, doing a business of \$10,000 the first year, and has grown rapidly and at the present time the volume of business has reached \$150,000 a year.

Hayes-Ionia Co., of Ionia, Mich., maker of automobile bodies sold by the Hayes Mfg. Co., Detroit, is to make bodies in Grand Rapids, where the factory of the Nelson-Matter Furniture Co. has been leased. Closed bodies will be manufactured there, and many of the employes of the Nelson-Matter company, skilled in fine woodwork, will be employed by the Hayes-Ionia Co. in turning out its finest bodies. The factory has 200,000 sq. ft. of floor space. The present plant in Ionia will be maintained.

### Parts Makers

Empire Axle Co., Dunkirk, N. Y., has awarded contract for an addition to its plant.

Ontario, Can., plant of the Kelsey Wheel Co., Detroit, was damaged by fire with a total loss of \$10,000.

Michigan Crown Fender Co., Ypsilanti, Mich., has increased its capital stock from \$100,000 to \$200,000.

W. K. Prudden & Co., Lansing, Mich., has changed its

name to the Prudden Wheel Co. The firm makes wood wheels.

John Redmond and A. Hanshaw, Detroit, will establish a factory at Lapeer to manufacture steel axles and wagon tongues.

Kuenz Radiator & Sheet Metal Co., Toledo, O., has been incorporated, with a capital of \$50,000, to manufacture automobile radiators. It is successor to the business of Joseph Kuenz.

Hayes Wheel Co., Anderson, Ind., has placed an order for \$10,000 worth of machinery for its plant. The company expects to manufacture from 1,200 to 1,500 sets of Ford automobile wheels daily.

Holland Demountable Wheel Co., capitalized at \$20,000, has been organized at Holland, Mich. Glen Thayer is president, and C. H. McBride, secretary and treasurer.

United States Radiator Corp. is preparing to resume manufacturing operations in its Detroit plant. It has been closed for the last five years. The plant will give employment to 500 men and will be opened at capacity.

Armstrong Steel Spring Co., Flint, Mich., has changed its corporate style to the J. B. Armstrong Mfg. Co. The company suffered a loss by fire March 2 estimated at \$25,000, throwing out about 75 workmen temporarily.

Columbus (O.) Union Oil Cloth Co. will be incorporated with \$500,000 capital stock and will take over the plants of the Columbus Oil Cloth Co. and the Union Oil Cloth Co. The capacity of both plants will be increased.

Auto Products Mfg Co., Cincinnati, has been incorporated with \$12,000 capital stock by Clifford Greene and others, to manufacture automobile parts. Its present plant is in Oakley, and tentative plans are under way for adding a forging plant. Details will not be available for several weeks yet.

Stewart-Warner Speedometer Corp., Chicago, has disposed of its electric clock business, developed at the Warner Works in Beloit, Wis., to the Waverly Novelty Co., Pittsburgh, which will continue to manufacture the devices at Beloit, under the direction of E. M. Thompson. For the present quarters will be leased from the Stewart company, but later a complete plant will be equipped in Beloit.

### Car Builders

Maxwell Motor Co., Detroit, Mich., has purchased a four-acre site at Windsor, Ont., and will erect a plant there.

Hamilton Motor Co., Grand Haven, Mich., is preparing its building for occupancy and will start operations within a short time.

The Elgin Motor Car Corp., Chicago, is planning the erection of additional factory buildings, which will triple its floor space.

Ford Motor Co., Detroit, is increasing its capacity to 3,000 automobiles a day. In January, 2,616 cars were turned out each working day.

Meteor Motor Car Co., Piqua, O., intends to increase the capacity of its plant at an early date. A power plant addition is one of the improvements planned.

States Motor Co., Kalamazoo, Mich., will be reorgan-

ized with a capital of \$6,000,000. It will include the States Motor Co. and the States Motor Car Mfg. Co.

Reo Motor Car Co., Lansing, Mich., has acquired the Gier Pressed Steel Co.'s factory. It recently acquired the old Bement plant, with a floor space of 44,000 sq. ft.

Pierce-Arrow Motor Co., Buffalo, has let contract for erection of a four-story factory, 60 x 400 ft., at its plant at Elmwood avenue and the New York Central Railroad Belt Line.

Hackett Motor Car Co., formerly of Jackson, Mich., has selected a site at Grand Rapids, Mich., and will shortly begin the construction of a building. F. R. Rothwell, Jackson, is secretary.

Darling Motor Co., Dayton, O., incorporated several weeks ago, has acquired the buildings of the Wright Aero-plane Co. and will fit them up for the manufacture of automobiles. The Wright plant has been moved east.

Dodge Brothers Motor Co., Ltd., Windsor, Ont., has been incorporated with a capital stock of \$100,000, by John F. Dodge, Horace E. Dodge, Frederick J. Haynes and others, all of Detroit, Mich., to manufacture automobiles, etc. It will establish a plant at Windsor, Ont.

International Motor Car Co., Allentown, Pa., has awarded a contract for the erection of a one-story addition, 50 x 240 ft., to be used as an assembling plant. The construction of two extensions, 50 x 54 ft., and 50 x 70 ft., has been completed, the first to be used for machine work.

Detroit Motors Co., Detroit, which has a capital stock of \$4,000,000, and is a recent merger of the Detroit Motor Car Co. and two manufacturers of motor car parts, is planning to enlarge its factory space and install equipment to produce 5,000 cars a year. W. R. Bamford will be president.

Barley Motor Car Co., Streator, Ill., will be moved to Mansfield, O., where a new company has been organized and incorporated with a capital stock of \$1,000,000, under the name of the Halladay Motor Car Co., to manufacture pleasure cars. It will occupy the plant formerly used by the Baxter Stove Co.

Holmes Automobile Co., recently announced to establish a plant in Canton, O., has been incorporated with a capital stock of \$2,500,000, and has elected the following officers: Arthur Holmes, president and treasurer; C. H. Rockwell, vice-president, and George W. Belden, secretary. It will either build a factory, providing about 120,000 sq. ft. floor space, or will acquire a building now unoccupied. Some machinery equipment will be purchased. For the first year, at least, the plant will be used mostly for assembling. The company will build its own engines, having the castings made in a Canton foundry, but its intention is to have other parts made outside.

### Dodge Brothers Lose Suit Against Ford

Dodge brothers lost their fight in the Michigan legislature against Henry Ford over the retention of \$2,000,000 surplus for expansion of the Ford Motor Co. The Dodge brothers wanted this distributed as dividends to stockholders. The Scott bill to permit corporations to increase their capital to \$75,000,000 was reported out by the House Committee without the Dodge amendment that corporations wishing to increase their capital must first distribute one-third of the accumulated earnings among stockholders.

### Death of J. M. Studebaker

J. M. Studebaker, famous manufacturer of carriages and automobiles, passed away March 16 at his home in South Bend, Ind., at the ripe age of 84. He was the last of the five brothers who established and built up the great Studebaker wagon and carriage industry. At the time of his death he was honorary president of the Studebaker Corporation, which succeeded the Studebaker Bros. Mfg. Co. a few years ago.

J. M. Studebaker was the son of John Studebaker, a lineal descendant of Peter Studebaker, one of three brothers who came to America from southern Germany in 1736 and settled in Pennsylvania. John Studebaker was a blacksmith and wagon maker near Gettysburg, Pa., when the decedent was born, October 10, 1833. Some years later he bought a farm near Ashland, O., and besides farming operated a blacksmith shop. In 1851 John was induced to locate at South Bend, Ind., by his sons, Henry and Clement, who had moved to that city, and engaged in wagon making.

J. M. Studebaker accompanied his father to South Bend, but remained there only a short time. In 1853 he and others of South Bend, yielding to the gold lure, went in a party to California. The trip was made overland in a wagon supplied by the decedent as his contribution to the expense fund. Arriving in California, he became acquainted with a blacksmith named Hinds, who advised him to give up the quest for gold and go to work for him. This advice was followed, and for the next five years he was employed in the Hinds shop, devoting his time largely to the making of wheelbarrows.

In 1858 Mr. Studebaker returned to South Bend and purchased the interest of his brother, Henry, in the business of H. & C. Studebaker. Henry then turned his attention to farming and later the two younger brothers, Peter and Jacob, were admitted to the firm. The small shop conducted by this firm was the humble beginning of the great Studebaker wagon, carriage and automobile business of today. J. M. Studebaker was actively connected with the management of the institution from the time he joined his brothers in 1858 until a few years ago, when advancing age forced him to retire. He remained on the board of directors, however, and in 1915 was chosen honorary president of the corporation.

Mr. Studebaker was married in 1860 to Mary Jane Stull, daughter of one of the pioneers of northern Indiana. He is survived by Mrs. Studebaker, one daughter, Mrs. Frederick Fish, and one son, J. M. Studebaker, Jr.

### Death of A. P. Cleaveland

A. P. Cleaveland, for many years traveling representative of the Firestone Tire & Rubber Co., and connected with that company almost from its inception, died in Florida on February 28. Mr. Cleaveland was a familiar figure at the conventions and exhibitions of the Carriage Builders' National Association, and his cheerful presence will be sadly missed at future gatherings of that organization.

### Death of Pioneer Carriage Builder

Edwin D. Foster, who was 92 years old and had lived in Elkhart, Ind., almost continuously since 1859, died recently. Death was due to stomach disorder. He was born in Granville, N. Y., in 1824. Mr. Foster, on his

arrival in Elkhart, had a blacksmith shop and later established the Foster carriage works. Eight sons survive Mr. Foster.

### Goodrich Opens 37 New Branches

During the past month the B. F. Goodrich Rubber Co., Akron, O., has opened 37 new stores in various parts of the country, in order to facilitate the distribution of Goodrich products. The stores are part of a large-scale system of merchandising now being established by the company. No less than 125 such establishments are to be opened before the system will be complete.

#### STATEMENT OF THE OWNERSHIP, MANAGEMENT, ETC., REQUIRED BY THE ACT OF CONGRESS OF AUGUST 24, 1912, OF THE HUB, published monthly at New York, N. Y., for April 1, 1917.

State of New York,  
County of New York, ss.  
Before me, a Notary Public in and for the state and county aforesaid, personally appeared G. A. Tanner, who, having been duly sworn according to law, deposes and says that he is the Business Manager of The Hub, and that the following is, to the best of his knowledge and belief, a true statement of the ownership, management, etc., of the aforesaid publication for the date shown in the above caption, required by the Act of August 24, 1912, embodied in section 443, Postal Laws and Regulations, to wit:

1. That the names and addresses of the publisher, editor, managing editor, and business manager are:  
Publisher, Trade News Publishing Co., 25 Elm St., New York, N. Y.  
Editor, G. A. Tanner, 25 Elm St., New York, N. Y.  
Managing Editor, none.

Business Manager, G. A. Tanner, 25 Elm St., New York, N. Y.  
2. That the owners are: (Give names and addresses of individual owners, or, if a corporation, give its name and the names and addresses of stockholders owning or holding 1 per cent or more of the total amount of stock.)  
Trade News Publishing Co., 25 Elm St., New York City,  
Estate of Joseph H. Wright, Tom's River, N. J.  
G. A. Tanner, 25 Elm St., New York, N. Y.  
Geo. W. Hills, Fairfield, Conn.

3. That the known bondholders, mortgagees, and other security holders owning or holding 1 per cent or more of total amount of bonds, mortgages, or other securities are: None.

4. That the two paragraphs next above, giving the names of the owners, stockholders, and security holders, if any, contain not only the list of stockholders and security holders as they appear upon the books of the company but also, in cases where the stockholder or security holder appears upon the books of the company as trustee or in any other fiduciary relation, the name of the person or corporation for whom such trustee is acting, is given; also that the said two paragraphs contain statements embracing affiant's full knowledge and belief as to the circumstances and conditions under which stockholders and security holders who do not appear upon the books of the company as trustees, hold stock and securities in a capacity other than that of a bona fide owner; and that affiant has no reason to believe that any other person, association, or corporation has any interest direct or indirect in the said stock, bonds, or other securities than as so stated by him.

G. A. TANNER, Business Manager.

Sworn to and subscribed before me this 4th day of April, 1917.

(SEAL)

JOSEPH R. FRITH,

Notary Public, New York County.

(My commission expires March 30, 1918.)

## WANTS

Help and situation wanted advertisements, 1 cent a word; all other advertisements in this department, 5 cents a word; initials and figures count as words. Minimum price, 30 cents for each advertisement.

**Wanted**—Copies of The Hub of May and July, 1916. Must be in good condition. Address Trade News Publishing Co., corner Elm and Duane streets, N. Y. City.

### PATENTS

**Patents**—H. W. T. Jenner, patent attorney and mechanical expert, 606 F St., Washington, D. C. Established 1883. I make a free examination and report if a patent can be had and exactly what it will cost. Send for circular.

### FOR SALE

**For Sale**—"Motor Body Work for Commercial Cars," a new text book dealing with the construction of all types of bodies for business purposes. Contains also six working drawings and a glossary of technical terms, together with diagrams and sketches. Price, \$1.20 net; by post, \$1.56. Orders should be accompanied by remittance. Cooper's Vehicle Journal, Ltd., 19 Garrick street, Long Acre, London, England.

# MACHINEBRONZE

CARRIED IN STOCK FOR YOUR CONVENIENCE  
BY OUR DEALERS

## CORED BARS

From 1/2 in. I. D. x 1 in. O. D. to 2 1/2 I. D. x 4 1/2 O. D. by 1/8 in.; 12 in. long.

## SOLID BARS

From 1/2 in. dia. to 4 1/2 in. dia. by 1/8 in.; 12 in. long.

**M**ACHINEBRONZE IS MADE TO FORMULA ESTABLISHED SOME YEARS AGO AS A STANDARD FOR AUTOMOBILE AND MACHINERY CONSTRUCTION AND REPAIR AND IS RECOMMENDED AS THE BEST GENERAL PURPOSE BRONZE ON THE MARKET

Ask us for the name of the dealer in your city who can ship these sizes at once  
**LUMEN BEARING COMPANY, BUFFALO**

# Yoder Sheet Metal Machinery

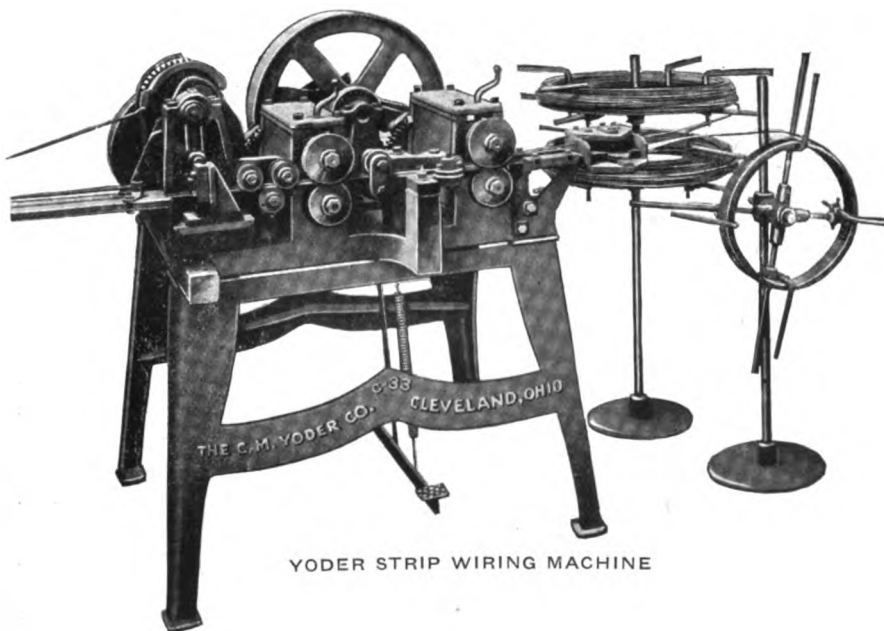

Our line of Auto Sheet Metal Working Machinery is efficient in every detail.

Every machine is constructed with the objective of producing perfect results at a minimum cost of material and labor.

The Yoder Company guarantees its machinery to produce results satisfactory to the purchaser.

We are glad to consider your Sheet Metal Machinery needs, as well as your requirements for special machines.

If you are thinking of making your own sheet metal parts or producing sheet metal products for the trade, get in touch with us at once. We can save you money and furnish a most satisfactory and complete equipment.

Catalog and prices furnished on request

## THE YODER COMPANY

Engineers Building

CLEVELAND, OHIO



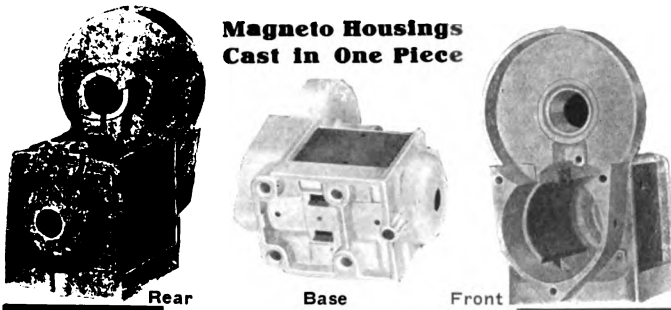

Magneto Housings  
Cast in One Piece

# Acme Die-Castings

## Accuracy Guaranteed

### Aluminum or White Metal Alloys

Acme Aluminum Die-Castings are a step in advance of anything heretofore done in this line. The Acme Patented Process permits higher daily production, better finish and a more consistent and accurate product. Metals used are substantially similar to Standard No. 12 Alloy containing 92 per cent aluminum and 8 per cent copper. Tensile strength about 20,000 lbs. to the square inch.

The service of our experts is at your command. Send us models or prints for estimate.



**Acme Die-Casting Corporation**  
 Bush Terminal Bldg. No. 6, 37th St. and 3d Ave.  
 Brooklyn, N. Y.

Boston—176 Federal St.  
 Philadelphia—Widener Bldg.  
 Detroit—865 Woodward Ave.  
 Chicago—549 Wash. Blvd.

**CANADIAN DISTRIBUTORS:**  
 Lyman Tube & Supply Co., Ltd., Montreal

## Index To Advertisers

Acme Die-Casting Corporation.....	38
Barrell Co., Wm. L.....	4
Bela Body Co., The.....	39
Bliss, E. W., Co.....	3
Bookwalter Wheel Co.....	42.
Bradley, C. C., & Son.....	41
Brennan Motor Mfg. Co.....	43
Columbus Bolt Works.....	Back cover
Cowles, C., & Co.....	42
Crane & MacMahon, Inc.....	Back cover
Decker, J. C.....	42
Dowler, Chas. L.....	42
DuPont Fabrikoid Co.....	4
Eccles, Richard, Co.....	42
Hoopes Bro. & Darlington.....	43
Hotel Brunswick .....	41
Hotel Tuller .....	38
Jenner, H. W. T.....	36
Johnston, R. F., Paint Co.....	42
Keratol Co., The.....	4
Laidlaw Co., The.....	2
Lumen Bearing Co.....	37
Millersburg Fifth Wheel Co.....	42
Mulholland Co., The.....	42
Murcott-Duden Co., The.....	2
Parsons Mfg. Co.....	2
Pettingell Machine Co.....	7
Pierce Co., F. O.....	Back cover
Porter, H. K.....	42
Pressed Steel Co. of New York.....	2
Rome-Turney Radiator Co.....	40
Russell, Burdsall & Ward Bolt & Nut Co.....	41
Sheldon Axle & Spring Co.....	6
Skinner, J. M., Bending Co., The.....	43
Smith, H. Collier.....	42
Smith Wheel, Inc.....	Front cover
Standard Oil Cloth Co., Inc .....	5
Technical School for Automobile Draftsmen.....	41
West Tire Setter Co.....	43
White-Quehl Mfg. Co.....	42
Wilcox Mfg. Co., D.....	43
Wiley Co., C. A.....	42
Williams, J. H., & Co.....	8
Wing, Chas., Co.....	42
Yoder Company, The.....	37



Meet me at the Tuller for Value, Service, Home Comforts

## NEW HOTEL TULLER

### Detroit, Michigan

Center of business on Grand Circus Park. Take Woodward car, get off at Adams Avenue.

**ABSOLUTELY FIREPROOF**

200 Rooms, Private Bath, \$1.50	Single, \$3.00	Up Double
200 " " " 2.00	" 3.00	" "
100 " " " 2.50	" 4.00	" "
100 " " " 3.00 to 5.00	" 4.50	" "

Total, 600 Outside Rooms

**ALL ABSOLUTELY QUIET**

Two Floors—Agents' Sample Rooms

New Unique Cafes and Cabaret Exellente

Please mention "The Hub" when you write.

# DISTINCTIVE BODIES



For Landaulets  
 Limousines  
 Sedans  
 Coupes  
 Roadsters  
 Touring Cars

Limousine body on Packard chassis. Note the pleasing effect of the special streamline cowl

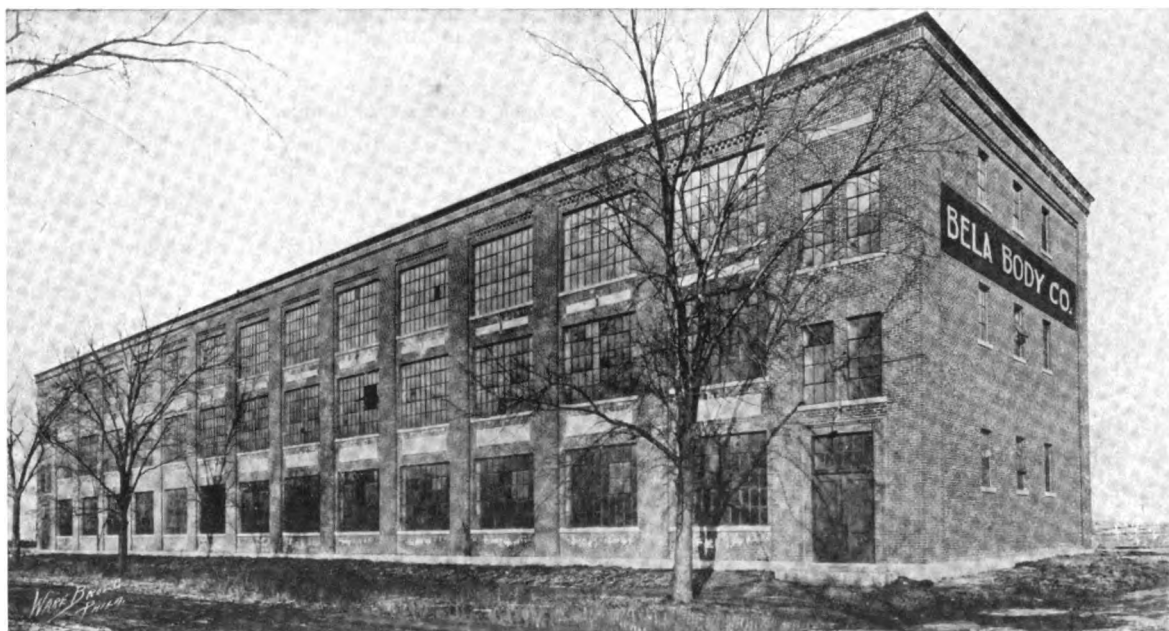

The Home of Bela Bodies

The above is one view of our Framingham Factory which is used for the painting, trimming and assembling of our bodies.

Our new 200 x 150 ft. building is under construction now, and will be ready for use in a couple of months. In this new shop our bodies will be built in the white. Both buildings will be equipped with the most modern of machinery and every facility for turning out the highest grade of work will be used.

We shall have our own spur track connecting with the N. Y. N. H. & H. R. R. and the B. & A. R. R., where we will load our bodies direct. Our shipping facilities are the very best.

## BELA BODY COMPANY

FRAMINGHAM, MASS.

AMESBURY, MASS.

Please mention "The Hub" when you write



## ROME-TURNEY

units represent extremely advanced engineering. We have built radiators of all types for 14 years and are specialists in designs developed for truck construction. No better radiators can be built. If this were possible we would build them.

### "RADIATOR INSURANCE"

SEAMLESS COPPER HELICAL  
TUBE COOLING SECTIONS

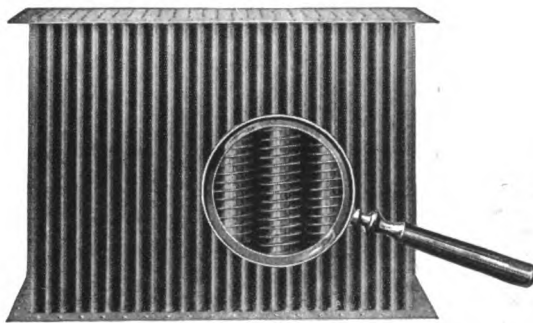

*Are Guaranteed for the Life of the  
Motor on Which They are Installed*

*Helical Tube Construction is Accepted as the  
Best by the Leading Truck Makers of America*

MANUFACTURED ONLY BY  
**ROME-TURNEY RADIATOR COMPANY**  
ROME, NEW YORK

When you install a  
**HELICAL TUBE RADIATOR**  
on your truck, you have the certainty  
that the radiator will make good or we  
will. We probably won't have to—  
**ROME-TURNEY RADIATORS**  
have a habit of making good them-  
selves. But if the cooling section devel-  
ops leaks, we will repair it free.

# CLASSIFIED INDEX

For Addresses See Alphabetical Index  
and Advertising Pages

#### AUTOMOBILES

American Motors Corp., Plain-  
field, N. J.

#### AUTO FABRICS

Barrell, Wm. L., Co., New York  
Keratol Co., The, Newark, N. J.  
Laidlaw Co., Inc., The, New  
York  
O'Bannon Corporation, New  
York City  
Standard Oil Cloth Co., New  
York City.

#### AXLES (Including Ball and Roller Bearing)

Sheldon Axle & Spring Co.,  
Wilkes-Barre, Pa.

#### BODIES

Bela Body Co., Framingham,  
Mass.

#### BOLTS AND NUTS

Columbus (O.) Bolt Works Co.  
Russell, Burdall & Ward Bolt  
& Nut Co., Port Chester, N.Y.

#### BOLT CLIPPERS

Porter, H. K., Everett, Mass.

#### BRAZING SLEEVES

White-Quehl Mfg. Co., Cincin-  
nati, O.

#### BRONZE BEARINGS

Lumen Bearing Co., Buffalo.

#### DIE CASTINGS

Acme Die Casting Corp., Brook-  
lyn, N. Y.

#### DIES

Bliss Co., E. W., Brooklyn, N.Y.  
(Sheet Metal Working).

#### FORGINGS

Eccles, Richard, Auburn, N. Y.  
(Carriage, Drop).  
Williams, J. H., & Co. Brook-  
lyn, N.Y. (Automobile, Drop)

#### FIFTH WHEELS

Millersburg Fifth Wheel Co.,  
The, Millersburg, Pa.  
Wilcox Mfg. Co., D., Mechanics-  
burg, Pa.

#### HARDWARE (Carriage, Wagon and Automobile)

Columbus (O.) Bolt Works Co.  
Dowler, Chas. L., Philadelphia.  
Eccles Co., Richard, Auburn,  
N. Y.  
Wilcox Mfg. Co., D., Mechan-  
icsburg, Pa.  
Wing Co., Chas., Amesbury,  
Mass.  
Cowles, C. & Co., New Haven,  
Conn.  
Parsons Mfg. Co., Detroit, Mich

#### LEATHER SUBSTITUTES

Barrell Co., Wm. L., New York  
Keratol Co., The, Newark, N. J.  
Standard Oil Cloth Co., New  
York  
DuPont Fabrikoid Co., Wil-  
mington, Del.

#### MACHINERY AND TOOLS

Bliss Co., E. W., Brooklyn, N.Y.  
Pettingell Machine Co., Ames-  
bury, Mass.  
Smith, H. Collier, Detroit, Mich.  
West Tire Setter Co., Roches-  
ter, N. Y.  
Williams, J. H., & Co., Brook-  
lyn, N. Y.  
White-Quehl Mfg. Co., Cincin-  
nati, O.

#### MACHINERY (Metal Working)

Bliss Co., E. W., Brooklyn, N.Y.  
Smith, H. Collier, Detroit, Mich.  
Yoder Co., The, Cleveland, O.

#### METAL STAMPINGS AND NOVELTIES

Murcott-Duden Co., Inc., New  
York  
Pressed Steel Co. of New York,  
New York City.

#### MOTORS

Brennan Motor Mfg. Co. Syra-  
cuse, N. Y.

#### PATENTS

Jenner, H. W. T., Washington,  
D. C.

#### PAINTS AND COLORS

Johnston Paint Co., R. F., Cin-  
cinnati, O.  
Pierce Co., F. O., New York.  
Sherwin-Williams Co., Clevel-  
land, O.  
Valentine & Company, 456 4th  
Ave., New York; 343 S. Dear-  
born St., Chicago; 74 Pearl  
St., Boston.  
Willey Co., C. A., Hunter's  
Point, N. Y.

#### PRESSES

Bliss Co., E. W., Brooklyn, N.Y.  
(Drop, Power).

#### RADIATORS

Harrison Mfg. Co., Inc., The,  
Lockport, N. Y.  
Rome-Turney Co., Rome, N. Y.

#### SCHOOL FOR DRAUGHTS- MEN

Mechanics' Institute, New York

#### SHAFT COUPLINGS

Bradley & Son, C. C., Syracuse,  
N. Y.  
Eccles Co., Richard, Auburn,  
N. Y.

#### SPRINGS

Mulholland Co., Dunkirk, N. Y.  
Sheldon Axle & Spring Co.,  
Wilkes-Barre, Pa.

#### TOOLS

Williams, J. H., & Co. Brook-  
lyn, N. Y.

#### VARNISH AND JAPAN

Parrott Varnish Co., Bridgeport,  
Conn.  
Pierce Co., F. O., New York.  
Sherwin-Williams Co., Clevel-  
land, O.  
Valentine & Company, 456 4th  
Ave., New York; 343 S. Dear-  
born St., Chicago; 74 Pearl  
St., Boston.  
Willey Co., C. A., Hunter's  
Point, N. Y.

#### WHEELS

Bookwalter Wheel Co., Miamis-  
burg, O.  
Crane & MacMahon, Inc., New  
York City.  
Hoopes Bros. & Darlington,  
Inc., West Chester, Pa.  
Smith Wheel, Inc., [Metal],  
Syracuse, N. Y.

#### WOOD BENDINGS, WHEEL STOCK, ETC.

Columbus (O.) Bending Co.  
Crane & MacMahon, Inc., New  
York City.  
Skinner Bending Co., J. M.,  
Toledo, O.

TEMPERED STEEL RING

LEATHER PACKING

# The Bradley Carriage Coupler

All-Steel Noiseless Quick-Shifting Ball-Bearing

(MADE IN FIVE SIZES FOR AXLES 1/4 INCH TO 2 1/4 INCH)

The only carriage coupler that is furnished with a **ONE-PIECE MOULDED LEATHER PACKING**

**C. C. BRADLEY & SON, Syracuse, N. Y.**

SHEET LEATHER PACKING

The Bradley Carriage Coupler

## Vehicle Mechanics

Desiring to improve their present Condition should attend the

### TECHNICAL SCHOOL

For

### Automobile Draftsmen and Mechanics

Supported by the

The National Automobile Chamber of Commerce, Inc.

The object of the School is to teach men to design vehicles and make working drawings, and to otherwise facilitate their work in the shop. Only those men employed in carriage or automobile building or their accessory trades are admitted to its privileges.

The classes are conducted in three divisions, viz.: Corresponding, Day, and Evening. The former is open during the entire year, while the day and evening classes are in session only from October 1 to April 1.

The tuition is moderate.

For prospectus and full particulars, write to the instructor,

**ANDREW F. JOHNSON,**  
20 West Forty-fourth St.,  
**NEW YORK CITY**

## THE BRUNSWICK

Boylston Street, Corner Clarendon,  
(Facing Copley Square)

**BOSTON - - MASS.**

High class modern house, intelligent service, pleasant rooms, superior cuisine.

Ladies traveling alone are assured courteous attention

European plan, single rooms, \$1.50 up; with bath, \$2 up; double, \$2 up; with bath, \$3 up.

American plan, \$4 per day up.

**FRED E. JONES - Proprietor**

### Results Always Follow Advertising in

# THE HUB

It Pays Others It Should Pay You

## RUSSELL, BURDSALL & WARD BOLT & NUT CO.

Established 1845 PORT CHESTER, N. Y.

**MAKERS OF THE CELEBRATED EMPIRE BOLTS AND NUTS**

Western Office: Continental & Commercial Bank Bldg., Chicago, Ill. Branch Works: Rock Falls, Ill.

Please mention "The Hub" when you write

Digitized by Google

# BUSY BUYERS BRIEFS

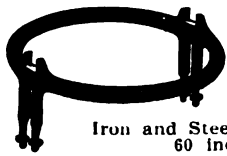

Manufacturers  
**FIFTH WHEELS**  
All Varieties  
Heavy Goods a  
Specialty

Iron and Steel Rings from 4 to  
60 inches wide  
**MILLERSBURG FIFTH WHEEL CO.**  
Millersburg, Pa.

WE MANUFACTURE  
**FINE VEHICLE  
WHEELS**  
The Bookwalter Wheel Co.  
MIAMISBURG, OHIO

**JOHNSTON'S  
KRAKNO**  
Color Card Free  
**\$3.50 per gallon**  
The R. F. Johnston Paint Co.  
Cincinnati, Ohio

## Why Not Have the Best?

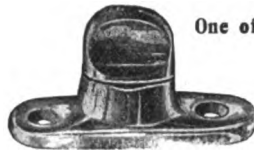

One of a Large Variety

**C. Cowles & Co.**  
NEW HAVEN,  
CONN.

**J. C. DECKER**  
MONTGOMERY, PA.  
Manufacturer of  
**Carriage, Skate and Pad Straps**  
Side Loops, Bridle Fronts, Tail Ties, etc.

**THE CHARLES WING CO.**  
Established 1848  
Manufacturers and Wholesale Dealers In  
**AUTOMOBILE AND CARRIAGE  
HARDWARE AND TRIMMINGS**  
AMESBURY, MASS., U. S. A.

**CHARLES L. DOWLER**  
CARRIAGE AND WAGON HARDWARE  
108 North Third St., Philadelphia, Pa.  
**CUSHION MANUFACTURER**  
Pure Stearic Acid Candles. Wheel Stock. Snow  
Flake Axle Grease.

**MULHOLLAND  
BUGGY SPRING**  
Reduces weight of springs one-half.  
Made in one size only but will fit bodies  
of all widths.  
Write for further particulars and prices.  
**THE MULHOLLAND CO. DUNKIRK, N. Y.**

**White's Brazing Sleeves**  
For applying Rubber Tires  
Send for Samples.  
**WHITE-QUEHL MFG. CO.**  
431 E. Pearl St.  
CINCINNATI, OHIO

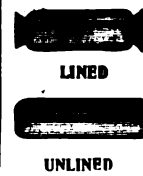

**"Quickwork"** Sheet Metal  
Working Machinery  
For Automobile and Carriage Bodies, Fenders, Hoods, etc.  
**H. COLLIER SMITH**  
807-815 SCOTTEN AVE. DETROIT, MICH.

**PORTER'S BOLT CLIPPERS**  
"Easy" "New Easy" Alca-Randall  
  
To Cut 5-16, 3-8, 1-2, 5-8, 3-4 Inch.  
**H. K. PORTER, EVERETT, MASS.**

# WILLEY'S COLORS

The Recognized Standard



**C. A. WILLEY CO.**  
COLOR GRINDERS

and Manufacturers of Specialties in

**CARRIAGE, AUTOMOBILE and CAR**

# PAINT

**COLORS, VARNISHES, ETC.**

**HUNTER'S POINT, NEW YORK CITY**

## High Grade Forgings

for CARRIAGE, WAGON, AUTO-  
MOBILE and SPECIAL WORK

ECCLES BALL-BEARING COUPLINGS are the BEST on the  
MARKET for DURABILITY and EASE OF ADJUSTMENT

LEATHER BUSHINGS ARE FAST-  
ENED IN THE SOCKET WHERE  
THEY BELONG

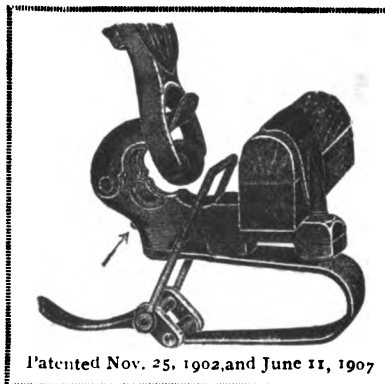

Patented Nov. 25, 1902, and June 11, 1907

SPECIAL FEATURE—THE SPRING  
IS PIVOTED AT THE FRONT TO  
ALLOW EASY ADJUSTMENT

Please bear in mind that we make a FULL LINE  
of Carriage and Wagon Forgings, also many of  
those for Auto and Special Work.

Send for our new Catalogs showing our Regular  
and Special Forgings.

QUALITY GUARANTEED. SERVICE—THE BEST

**Richard Eccles Co.**  
AUBURN, NEW YORK





## The Hub

### AUTOTRUCK

#### Hickory Nut and

BEST QUALITY STOCK  
TOUGH AND HEAVY  
BONE DRY

MANUFACTURED BY  
CAPABLE MECHANICS  
AND MOST  
IMPROVED MACHINERY

WHEELS WHICH ADD TO  
THE LIFE OF YOUR TRUCK

ST. MARYS, OHIO

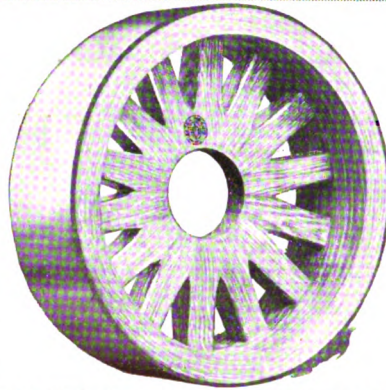

### WHEELS

#### Acorn Brands

HORSE-DRAWN  
VEHICLE WHEELS  
ALL STYLES

TRAILER WHEELS:  
SARVEN AND  
ARTILLERY TYPES

HIGH STANDARD OF  
QUALITY AND  
WORKMANSHIP  
MAINTAINED

8 BRIDGE ST., N. Y. CITY

CRANE & MacMAHON, Inc.

# W. O. PIERCE CO.

NEW YORK,  
U. S. A.

Manufacturers of High Class  
Pigment Colors from ORIGINAL  
FORMULAE. Colors ground in Japan  
and other MEDIUMS to meet any  
SYSTEM of APPLICATION.

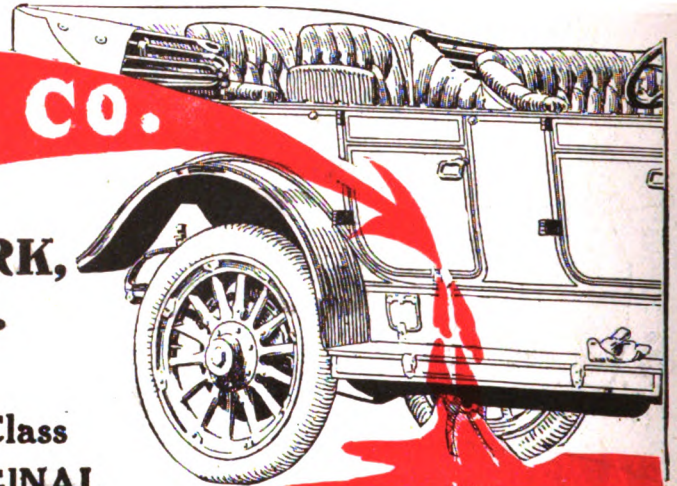

UZATONA  
RED

We can now furnish Uzatona Reds ground in Japan, Oil or Varnish.  
Prices upon application

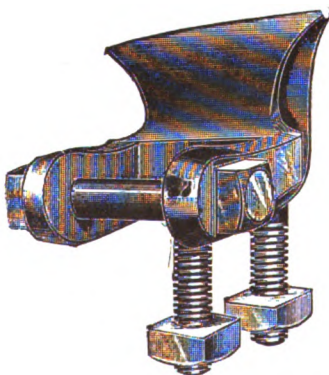

### Skewed Shaft Couplings

#### Regular or Oval Patterns For High Arched Axles

Furnished in rights and lefts for any height of arch.  
Oval Axle Clips  $\frac{5}{8}$  or  $\frac{3}{4}$  width to match Oval  
Couplings. Bolts, Clips, Couplings, Carriage  
Hardware and Special Forgings

Catalogue "H" and Prices on Application

**COLUMBUS BOLT WORKS COMPANY**

COLUMBUS, OHIO

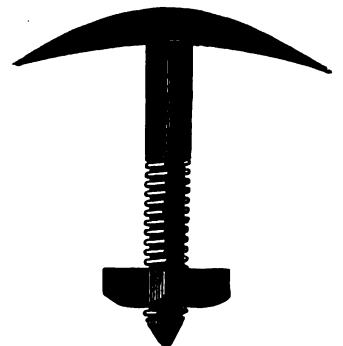

# The Hub

First Journal of the Vehicle Industry

Vol. LVIV

NEW YORK, MAY, 1917

No. 2

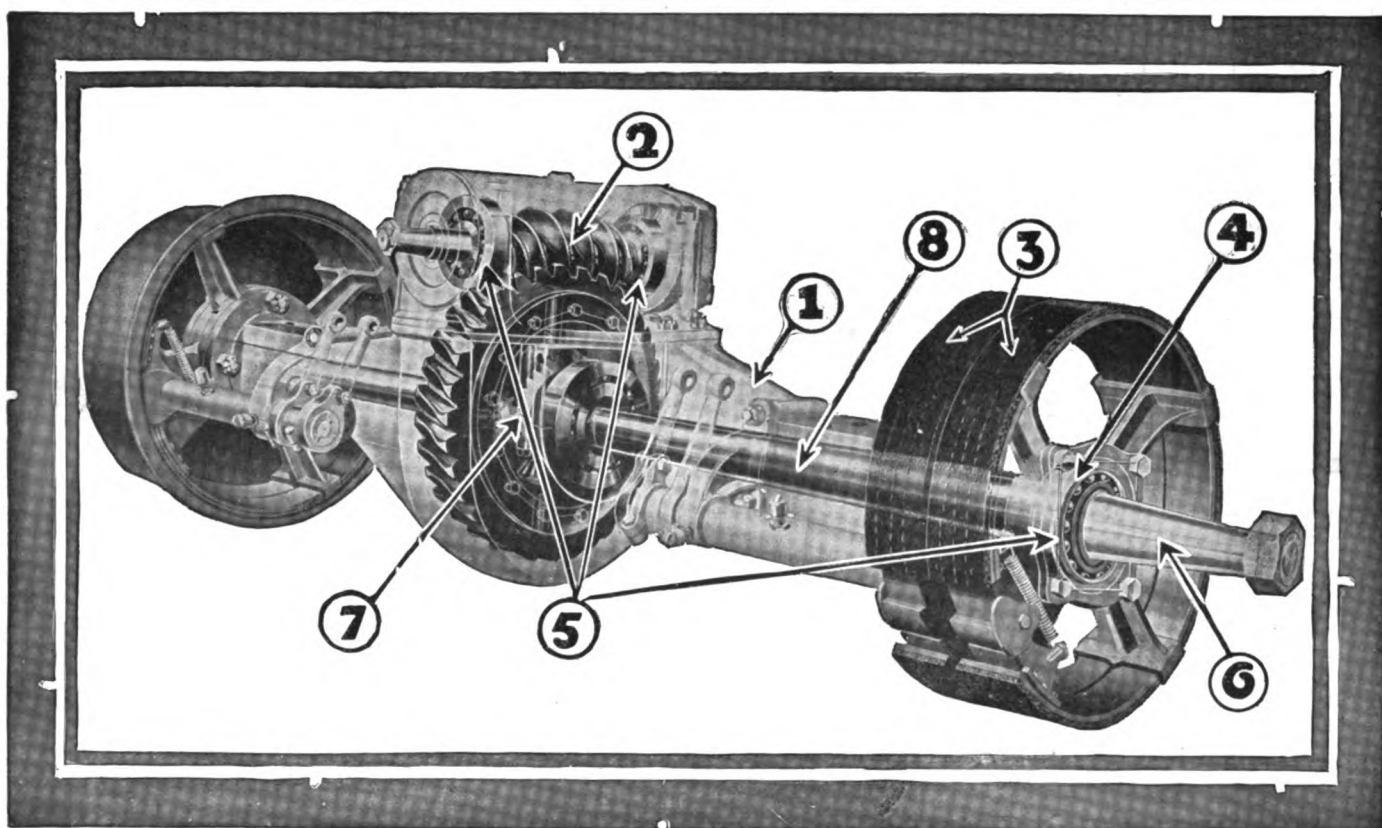

## Why SHELDON Worm Gear Rear Axles Are Better Axles

- ① One piece cast steel housing—built like a bridge and just as strong—lightest and strongest type of construction known.
- ② Straight or David Brown type worm—highest efficiency—longest life—guaranteed for one year—mileage of 100,000 miles and upwards frequently reported.
- ③ Double internal brakes—powerful, quick-acting, unfailingly sure. All working parts enclosed and protected from foreign substances—unequaled for economy of upkeep.
- ④ Semi-floating wheel bearing construction—fewer parts—lighter weight—greater strength—economy of manufacture and operation.
- ⑤ Ball-bearing mounting throughout—high efficiency—bearing adjustments eliminated.
- ⑥ Tapered hub mounting—permits of demountable wheel—makes tire changes quick, easy and economical.
- ⑦ Oversize differential—never wears out—built to outlast the truck.
- ⑧ Big husky drive shaft— $3\frac{1}{2}$  per cent nickel steel forging—correctly heat treated—tapered from differential to wheel bearing—gives strength where needed for every character of stress imposed upon it.

**THE SHELDON AXLE & SPRING CO.**

Makers of Springs and Axles for Heavy Duty Service for over 50 years  
Wilkes-Barre - - - - - Penna.



# PARROTT VARNISHES



.. Unequaled for ..

**Automobile  
and  
Carriage  
Finishing**

**The Parrott Varnish Co.**  
Bridgeport, Conn.



## SEAMLESS TUBING STEEL—BRASS—COPPER

Send Us Your Specifications  
for Rush Requirements

**MURCOTT-DUDEN CO., Inc.**  
253 Broadway New York



## steel stampings

*especially for*  
**COMMERCIAL TRUCKS**

**The Pressed Steel Co. of N. Y.**  
Woolworth Bldg.

## The Laidlaw Company Inc.

New York City

.....

**Automobile  
Fabrics**

.....

**A Fabric for  
Every Purpose  
For Closed, Open or  
Convertible Bodies**



# There is a size that will successfully meet your exact requirements

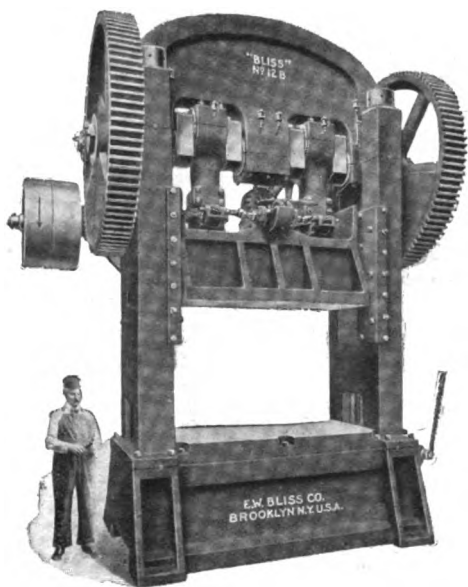

Presses with correct proportions for use in the manufacture of large sheet iron and steel goods. The large diameter shafts and well-gibbed sides allow quantity production that's profitable.

## Bliss Double-Crank Presses

Adapted for the economical production of vapor stoves, wrought iron ranges, agricultural implements, automobile stampings, steel car parts, ceilings, sidings, metal doors, window frames and sashes, metal furniture and similar goods.

Built in over 150 sizes, there is one adapted to your special requirements. Write today for descriptive matter.

*Talk to us about presses for any and every requirement*

## E. W. BLISS CO

38 Adams St., Brooklyn, N. Y.

Chicago Office: Peoples Gas Building.

Detroit Office: Dime Bank Building.

Cleveland Office: Union Bank Building.

Offices in Europe: 100 Boulevard Victor-Hugo, St. Ouen, Paris; Pocock St., Blackfriars Road, London, S.E.



**Mechanics Demand**

**Turn Where You Will  
The World Employs**

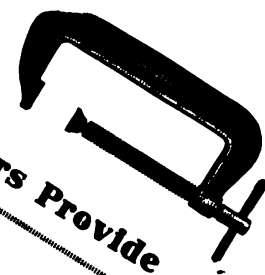

**Dealers Provide**

## Williams'

GRAND



PRIZE

## Drop Forged Tools

J. H. WILLIAMS & CO.

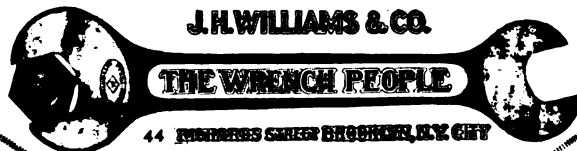

**Publicity Promotes**



**Makers Guarantee**

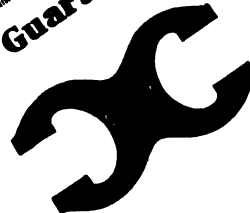

Please mention "The Hub" when you write.

**Note the opposite announcement  
Here is a 1917 money-making opportunity  
Investigate it!**



Louis Chevrolet's O. K.  
is your guarantee

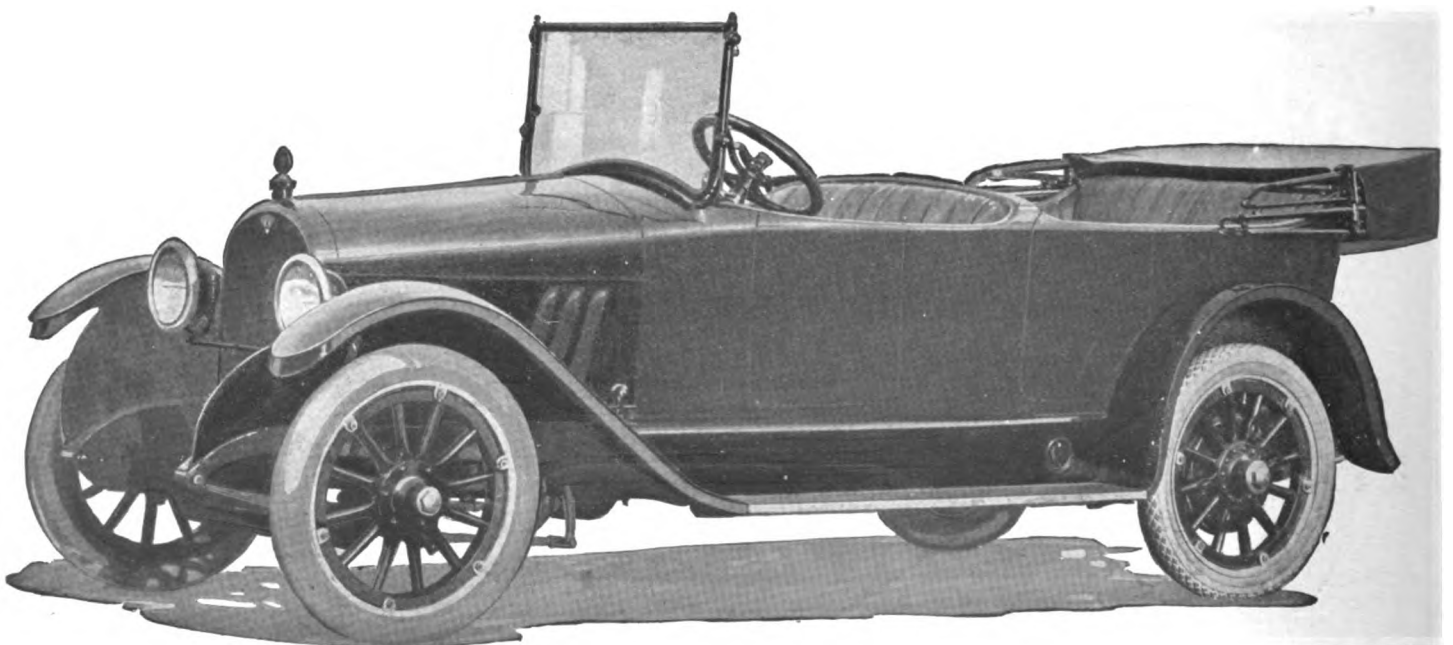

**AMERICAN SIX, built in Plainfield, New Jersey**

Please mention "The Hub" when you write

# EASTERN CAR DEALERS!

Here is an honest-to-goodness  
**OPPORTUNITY**  
 to make money **NOW**

**EMBARGO or  
 NO EMBARGO**  
 You can get  
**American Sixes  
 NOW.**

**Come to  
 Plainfield.**

**Look us over.  
 Inspect our modern,  
 up-to-the minute  
 manufacturing plant.**

**45 H. P.  
 122 in. wheelbase.**

Louis Chevrolet's latest achievement, the American Six, is made in Plainfield, New Jersey, just 25 miles from New York City.

That means very low freight (none at all to you who are right close by).

Deliveries are *NOW*—and as you want them during the season.

The new discount is an interesting one.

The extent to which we go on genuine co-operation is unusual.

No car manufacturer in the country can offer you the money making possibilities that we offer you for 1917. We are in a fortunate position. You can cash in on it.

The output is limited—quick action is essential.

If you wire for reservation, send it collect.

# AMERICAN SIX \$1375

**AMERICAN MOTORS CORPORATION, Plainfield, N. J.**

(25 miles from New York City)

Please mention "The Hub" when you write

# MERITAS LEATHER CLOTH

## Quality Is the Foundation of the Leading Leather Substitute

Meritas Leather Cloth is made by the world's largest specialists in this line.

Meritas Leather Cloth is the result of long experience, special machinery and expert knowledge unequalled in this field.

Meritas Leather Cloth has for many years given complete satisfaction in all lines requiring a good looking, excellent wearing leather substitute.

Meritas Leather Cloth is extremely popular with carriage and automobile manufacturers because it is the next best material to expensive leathers.

Meritas Leather Cloth is made in an extensive range of weights, colors, grains and finishes sufficient to meet every need for a high grade leather substitute.

Always look on the back of the goods for the trademark.

Write for samples  
to meet your specific requirements

**The Standard Oil Cloth Company**

INCORPORATED

320 Broadway

New York



Please mention "The Hub" when you write.

# The United States Government

## War Department

when calling for proposals and bids for machinery  
recently specified machines made by the  
**PETTINGELL MACHINE CO., AMESBURY, MASS.**

In an emergency the United States Government  
Engineers want the best—machines that can be  
depended on to do the work at all times, so they

## SPECIFIED THE PETTINGELL MACHINE CO.'S MACHINES

**THIS FACT SPEAKS VOLUMES**  
When you want the best order PETTINGELL Machines

**Bevel and Mitre Saw Tables      Improved Saw Tenoners**  
**Irregular Shapers**

**Automatic Power Hammers      Friction Drive Rotary Metal Cutters**  
**Beading and Moulding Formers      Rolling Machines**  
**Foot Presses      Cornice Brakes, Etc.**

MANUFACTURED BY

# THE PETTINGELL MACHINE CO.

AMESBURY, MASSACHUSETTS



***Hartford***

**DEPENDABILITY** has increased our  
sales **772 per cent** in two years

THE QUALITY of our Product  
THE SERVICE we give our customers  
THE DELIVERIES we are able to make  
Plus our standing financially  
are considerations worthy of serious thought  
when you are in the market for

**UNIVERSAL DRIVES AND  
CONE CLUTCHES**

---

**HARTFORD AUTO PARTS CO.**  
HARTFORD, CONN.

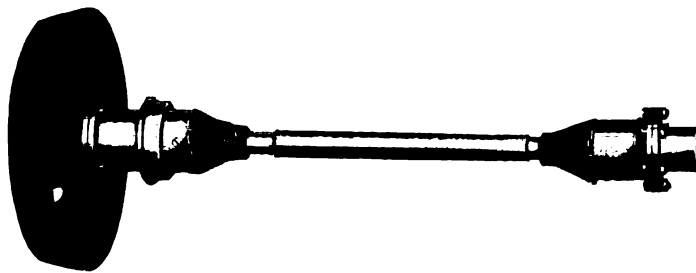

Please mention "The Hub" when you write.



# The Hub

Vol. LVIV

NEW YORK, MAY, 1917

No. 2

Published Monthly by

## THE TRADE NEWS PUBLISHING CO. OF N. Y.

PAUL MORSE RICHARDS, *President* G. A. TANNER, *Secretary and Treasurer*  
EDISON BUILDING, COR. ELM AND DUANE STS., NEW YORK

THE HUB, a monthly authoritative journal on all subjects pertaining to the vehicle industry from its engineering and construction viewpoints. It publishes information of live interest to manufacturers of motor vehicles, trailers, carriages, wagons, the accessory trades, repair shops and garages.

Subscription price for the United States, Mexico, Cuba, Porto Rico, Guam, the Philippines, and the Hawaiian Islands, \$2.00; Canada, \$2.50; payable strictly in advance. Single copies, 25 cents. Remittances at risk of subscriber, unless by registered letter, or by draft, check, express or post-office order, payable to the order of THE TRADE NEWS PUBLISHING CO.

For advertising rates apply to the publishers. Advertisements must be acceptable to publishers. Copy for new advertisements must be received by the 25th of the preceding month. All communications must be accompanied by the full name and address of writer.

Entered in the New York Post Office as Second-class Matter

## Penalizing Economical Methods

Our readers have had their attention called to the action of Congress in attaching riders to appropriation bills virtually forbidding the use of premium or so-called efficiency methods in government workshops. The practice had developed in the machine shops of the arsenals of making a scientific study of the work of each class to determine the routine which involved the least exertion on the part of the workman and accomplished the highest results. Having determined this and how much product constituted a fair day's work, the regular wages were established upon this basis, but a system of premiums was established under which the workman might increase his own pay by acquiring more than average efficiency. The system gave improved results to the government and larger earnings to skillful men. It was abolished by acts of Congress taking effect July 1, 1916, over the opposition of the heads of the arsenals and of the present Secretary of War.

At recent hearings before the House Committee on Military Affairs, Gen. Crozier, Chief of Ordnance, made a showing of the decline of output following the abandonment of the premium system.

He presented to the committee 49 comparative instances selected at random of the same job done under the forbidden bonus system and under the present day wage payment. The first job on the list was retapping the base of 4.7 in. shells. The worker in question, under the premium system of payment, had done 100 of these shells in ten hours. The second 100, done immediately afterwards, were done in 22.95 hours. That is to say, it took him two and three-tenths times as long to do the same amount

of work under the day-rate system of payment as it took him under the premium system.

As a general result of abolishing efficiency methods in the Watertown arsenal, Gen. Crozier testified that within a few months the cost of production increased 2.2 times. He stated that the object of the study was not "to ascertain the quickest possible time in which work can be done, but to ascertain the time in which work can reasonably be expected to be done, without injury or disagreeable effect to the workman."

This is an unpleasant showing to come at a time when the government is facing enormous expenditures, and there is a shortage of man-power in the industries on every hand.

## Loyal Co-operation for the War

This war has now lasted nearly three years and become the most awful tragedy of history. It overshadows all human affairs, and the supreme task of the time is to bring it to an end, if possible, under conditions which will give some assurance against the recurrence of a similar calamity in the future. In this task the United States is now joined, and until it is accomplished all energies which can be effectively directed to this end should be so devoted. The government rightfully has a first call upon all the resources of the country for this purpose, and the steps which it is taking indicate that it intends to organize its forces of men, equipment, materials and credit as rapidly as possible. There is every evidence of loyal co-operation. The owners of industrial works producing munitions and other war supplies are freely offering their establishments for government service, upon terms to be fixed by the latter; the railway companies have practically merged their properties into one organization for the purpose of giving the country the most efficient service possible; the leaders of organized labor have pledged themselves not only to support the government but to work in harmonious industrial relations; the farmers, with inspired energy, have set about increasing the yield of foodstuffs; the bankers have tendered their services without charge in the flotation of loans, and there is manifested on all sides a willingness to do whatever task is assigned.

## Railroads Organize for the War

The railroad companies, in view of the enormous pressure upon their facilities, and the importance of rendering the most efficient service possible during the war, have taken a step which may prove to be epoch-making in its lasting results. It is nothing less than the consolidation

of all the railroads of the country under one management for operating purposes.

This action is highly creditable to the railway officials and it is evident that the plan will give the community an exceedingly interesting experiment. It is not doubted, says the National City Bank of New York in its bulletin, that important economies will be accomplished, but it remains to be seen how great they will be and how the individual companies will fare under the arrangement. If there are great gains to the public it is scarcely conceivable that the organization will ever be dissolved and roads go back to independent and competing operations.

This country will not be and should not be content with anything less than the best and most economical railway service that can be had. In the past it has been the public policy to compel the railroads to compete, although the advocates of government ownership have claimed that great advantages would be realized by consolidating the lines under one management. Possibly a system can be worked out combining the benefits claimed for government ownership with the benefits of private ownership and management. The problem is too complex for hasty conclusions, but permanent good should come from the experience.

### The Metric System in Great Britain

The tremendous change that has taken place in Great Britain during the past three years manifests itself in numerous ways. In the field of engineering, perhaps no indication is more significant than the fact that Engineering, in a leading editorial, in the issue of March 30, entitled "The Metric System," takes a friendly view toward the adoption of the metric system in Great Britain and, while retaining its usual well balanced judgment on engineering questions, expresses opinions that can be understood in no other way than as an advocacy of the metric system. This, indeed, would have been unbelievable and unheard of three years ago.

"There are only two system possible in this country (Great Britain)," says Engineering, "our own and the system which is already obligatory with 437,000,000 people and optional with 727,000,000 in other countries. . . . The adoption of the metric system in this country has been largely treated as an academic question in the past. In spite of our system—or want of system—we have been successful, and our exports have risen with satisfactory uniformity. We have made money, we have amassed capital, and we have spent lavishly. But we are now entering upon another phase under quite new conditions. After the proclamation of peace we shall be faced with greatly increased wages and enormous taxation, and the national income, which was once ample, will no longer suffice. Prices will be high, and although the working classes will be able to spend, the middle classes with fixed incomes will be obliged to curtail their outlay. Under such conditions we must extend our trade abroad by every possible means, and to do so we must copy our rivals—that is, we must take trouble to meet the desires of our customers. The first step toward that end is to count the cost and to compare it with the possible gain, and, if the calculation shows a profit, to go forward. It must be remembered that the cost is not a continuing one. Once the outlay and confusion attending the change have been encountered, they are at an end, while the profit will go on from year to year."

It is further mentioned that since 1840, 34 countries have abandoned their original standards and adopted the metric system. Not one country has adopted the British measures, and no country has abandoned the metric system and gone back to its old units. Engineering, however, by no means underestimates the difficulties of a change. It recognizes that "in no country was the change so difficult as it will be here, for in none was manufacture so highly organized. We shall have to pay for our footing when we enter the community of metric countries, and the point that waits for settlement is what it will cost us. . . . Our own impression is that the cost will be found to be very much less than many anticipate."

The above statement from Engineering is reproduced because of the peculiar interest to American engineers at the present time, when the subject is again being considered in this country, and when two organizations have been founded, one known as the American Institute of Weights and Measures, the object of which is to oppose the metric system, and the other, the American Metric Association, the object of which is to further the adoption of the metric system in the United States. The activities of these two organizations will tend to make the subject more thoroughly understood by engineers in the United States, and in the course of discussions that will take place, much valuable information, both for and against the metric system, will, no doubt, be placed on record. Should Great Britain adopt the metric system, it is evident that the question of its adoption in the United States will become more acute than ever, and the more authoritative and unbiased opinions on the subject that can be placed before American manufacturers and engineers, the more easily will a decision be reached when the time comes that a decision must be reached.

### Military Truck Specifications

At the meeting of the standards committee of the Society of Automotive Engineers just held in Cleveland the military truck specifications, which had been prepared by the War Department Motor Transport Board, in consultation with the truck standards division, the transmission division, the springs division and the electrical equipment division of the society, were submitted for general consideration and the work of these divisions was approved.

It was decided by the standards committee to request that the designation of the military trucks be by arbitrary terms rather than nominal terms of capacity. The War Department has accordingly ordered that the smaller military truck heretofore designated 1½ ton shall be named Class A truck, and the truck formerly designated 3-ton be called Class B truck. The trucks have a greater capacity than their former nominal designations indicated. An engine of a minimum size of 312 cubic inches is specified for the Class A truck. This means that if a four-cylinder engine is used it would have a bore and stroke of 4¼ and 5½ in. respectively. Likewise a four-cylinder engine of the Class B truck would have a bore and stroke of 4½ and 6½ in., the minimum engine size being 413½ cu. in.

The truck standards division of the Society of Automotive Engineers is still conducting work with regard to the military truck specifications. A meeting will be held in Washington at an early date to take up details with reference to parts and features not ordinarily found in commercial practice, with a view to obtaining maximum production of and interchangeability in military trucks.

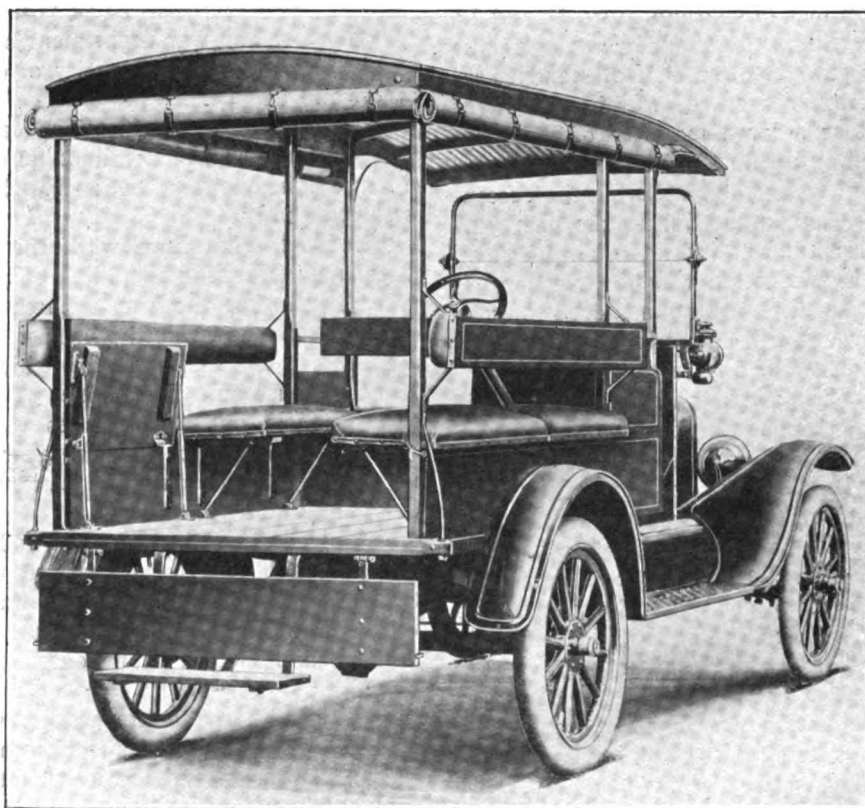

**PASSENGER BODY**  
Built by the Columbia Wagon Co., Columbia, Pa.

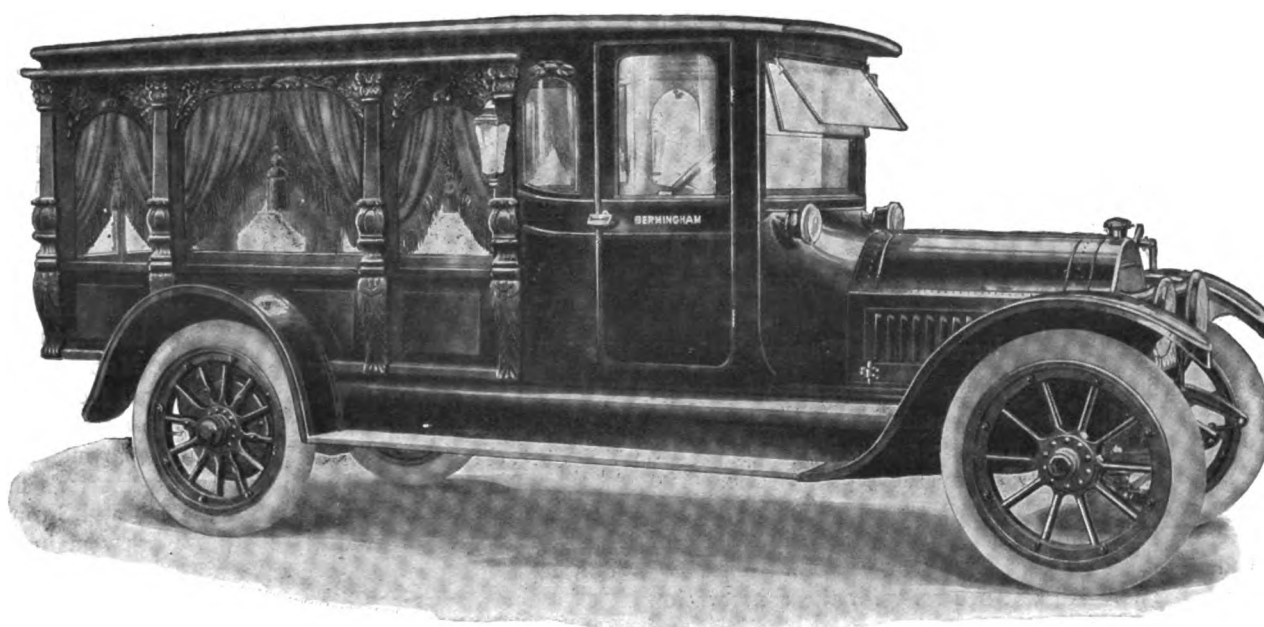

**MOTOR FUNERAL CAR**  
Built by August Schubert Wagon Co., Oneida, N. Y.

## Wagon Makers Discuss Needs of Government for Army Wagons

The farm wagon department of the National Implement and Vehicle Association met in Chicago, April 11 and 12, those attending representing the manufacturers of the bulk of the wagon output. A discussion of standardization following the verbal reports of members brought out the information that a large majority of manufacturers are rapidly cleaning up non-standard material and hope to be on a strictly standard basis during the present year. A large part of the output during the past year was standardized product, and as indicated, only a small portion of this season's production will be irregular. It was the general opinion that in the standard wagons already adopted the farmers will find types that will meet the reasonable requirements of any territory.

Many localities have asked and others doubtless will ask for special types of wagons outside of the standardized list. It is the purpose of the wagon manufacturers to provide a product to meet the requirements of the farmer. The sentiment of those present was that the standardized wagons will meet such requirements. Further standardization and elimination was considered and committees were appointed to investigate the matter of a standard box for wagons, also the advisability of establishing standard uniform front and hind wheels for wagons and trucks and to report at the next meeting.

The manufacturing situation was carefully considered, particularly the ever increasing cost of materials, such as steel and iron, a situation which suggested the imperative necessity of careful study and analysis on the part of every manufacturer of material supply and cost of production.

A uniform wide tire law was suggested for consideration and the government pamphlet relating to standard sizes for wide tires was fully discussed. It was the consensus of opinion that in approaching this very difficult subject of a uniform wide tire law, the manufacturers should try to arrive at a conclusion that would be acceptable to consumers throughout the entire country. Discussion of this matter was summed up in the following resolution:

"That this association, through the trade publications, make the statement that it recommends that the legislative bodies of the various states give consideration to the recommendation of the government as expressed in its pamphlet on the subject whenever they consider wide tire legislation."

### Government Requirements for Wagons

The government requirements for army transport wagons received the earnest consideration of the department, as it was realized by everyone that these requirements must take precedence over everything else. The following resolution was adopted:

"Whereas, This country has been declared in a state of war, and

"Whereas, There is great necessity for the conservation of its resources, both natural and those of production; and

"Whereas, Some of these needs and requirements include freight and transportation vehicles, particularly for the army, which manufacturers represented by this association are peculiarly fitted to supply; therefore, be it

"Resolved, That we recommend to the executive committee of this association that an assurance of our interest

be transmitted to the authorities at Washington to the end that attention be given to our facilities for rendering service."

### Recommendation to War Department

"Whereas, The war department of our government has issued proposals for a quantity of escort wagons for the army, and

"Whereas, these specifications call for materials of a special character which cannot be obtained in the quantities seasoned as required, except through unusual delay; therefore, be it

"Resolved, That in view of the fact that time is an important element in the filling of these requirements, we recommend that the war department substitute wagon gears of the standardized pattern recently adopted by this association, the materials for which are obtainable for immediate use and the facilities of factories adequate for turning them out in quantities within reasonable time. The boxes or beds to fit these gears can be furnished as required by the present specifications without unusual difficulty; and be it further

"Resolved, That the president and the secretary of this department be hereby authorized to communicate with the proper authorities to the end that these recommendations be given attention, and our willingness to render services and facilities for doing so be made known to them."

On the 12th the entire session was devoted to farm trucks. A large number of concerns were represented.

Standardization and the manufacturing situation occupied nearly the entire time. The manufacturers were requested to review previous recommendations and come prepared to report at the next meeting what had been accomplished and suggestions for further standardization and elimination. A special committee was appointed to consider a number of suggestions made at the meeting and to report at the coming meeting.

The difficulty of obtaining necessary material was recognized by everyone, particularly in view of the probable requirements of the government. It is almost beyond question that both steel and wood stock will command much higher prices.

In view of the unsettled conditions and the difficulty of planning very far ahead, it was decided to hold the next meeting in about 30 days.

### Activities of the S. A. E.

A Washington office has been opened by the Society of Automobile Engineers (hereafter to be known as the Society of Automotive Engineers) in the Munsey Building in connection with the Council of National Defense. This action was taken to bring about closer co-operation of the society with the various government departments. The society has co-operated with the Quartermaster's department in drawing specifications of the 1½ and 3-ton military trucks. A great deal of other work remains to be done.

Because of war conditions, the summer meeting scheduled to be held the last week in June at Ottawa Beach, Lake Michigan, has been called off. An extensive canvass of many connected with the activities of the society showed a general feeling that few of the members could afford to spend four days at the summer meeting. Instead of four days at Ottawa Beach, it was voted to spend one day on the summer meeting at Washington, D. C.

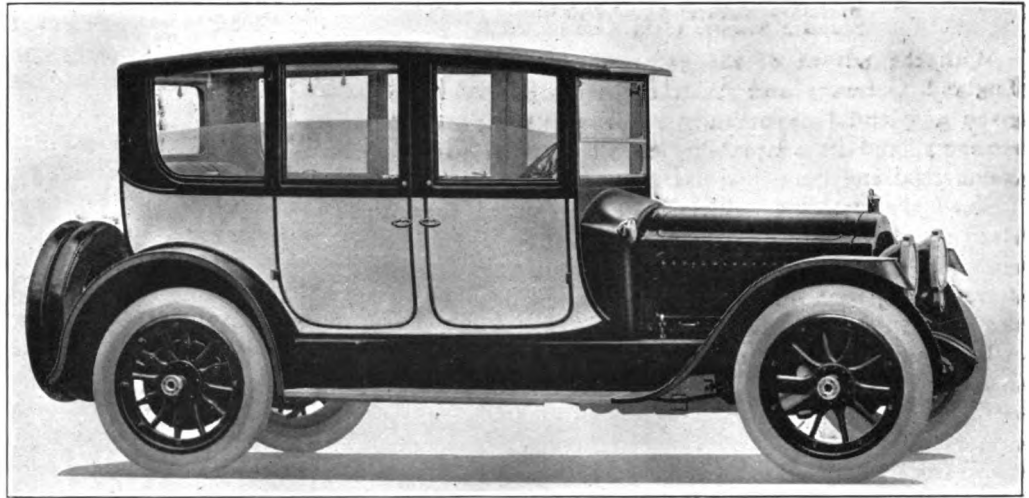

**2-25 FOUR-PASSENGER BROUGHAM**  
Built by the Packard Motor Car Co., Detroit

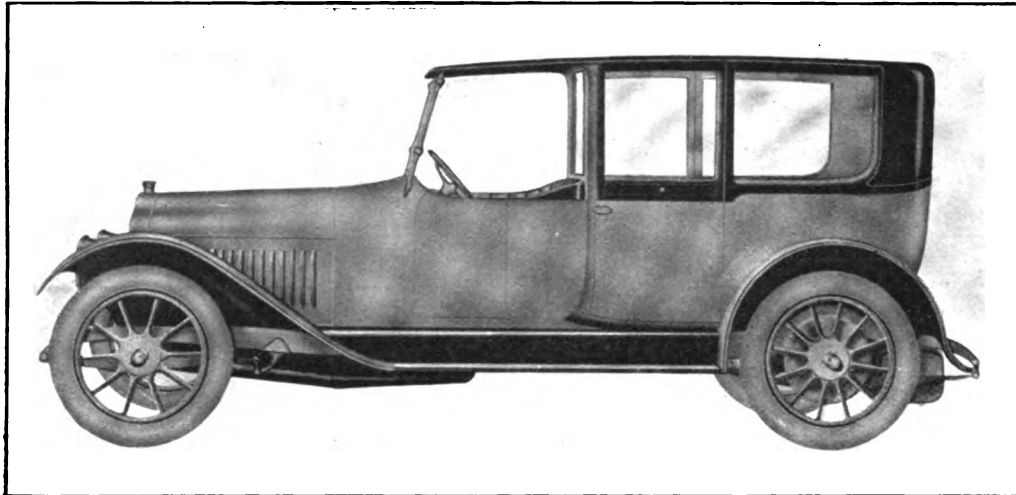

**LIMOUSINE**  
Body by the Rubay Co., Cleveland. Mounted on White Chassis

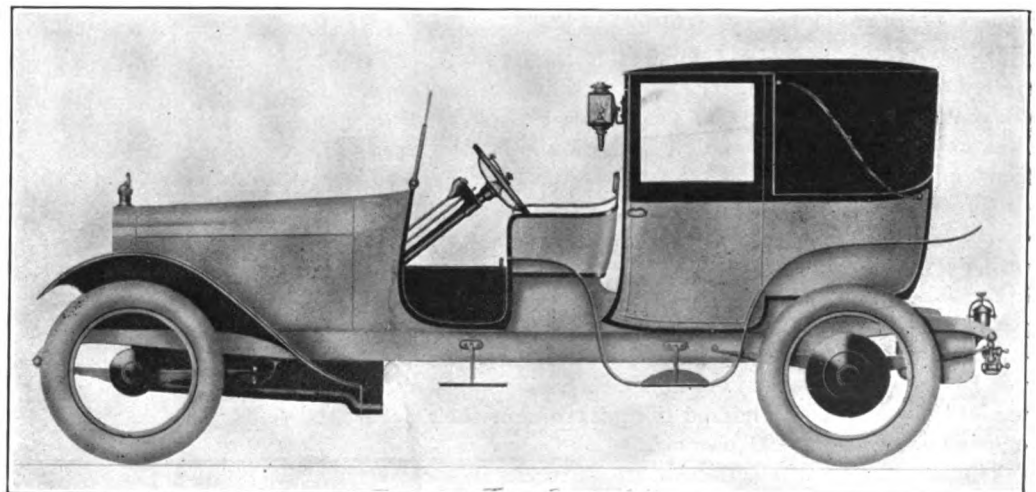

**TOWN LANDAULETTE**  
Body by Fleetwood Metal Body Co., New York. Mounted on Packard Chassis

### The Electric Vehicle and the War

By A. JACKSON MARSHALL,  
Secretary Electric Vehicle Section  
National Electric Light Association

With the advent of the great war, and especially in England, Germany and Austria, the electric vehicle was given a splendid opportunity to prove its dependability, economy, and its adaptability to all sorts of passenger, commercial and municipal uses.

Since the gasoline vehicle is better suited than the electric to the field of battle, nearly all the gasoline automobiles, both passenger and commercial, were commandeered along with all the best horses, and in many cases the skilled drivers were requisitioned with their vehicles. A large number of electric vehicles were ordered to handle urban transportation, and inexperienced men, and to an even greater extent, women were obliged to become the drivers of these vehicles. The electricians met these conditions admirably, because of their simple mechanism and ease of operation, and the new drivers rapidly mastered their simple problem of operation.

With an abundance of coal for making current, England naturally could operate electric vehicles more economically than gasoline cars, because of the present scarcity of gasoline, and its attending exorbitant price. In 1914, at the beginning of the war, there were only 150 electric vehicles in use in England, and the number has increased in 2½ years to 858, which increase is nearly six times the number of electricians which had been put into use in England during the ten years previous to the war.

Since both Germany and Austria have been cut off from the world's supply of petroleum, and because electric current is unusually cheap, due to the abundance of coal the Germans are mining from the territory in France which they hold, the use of electric vehicles in these countries has been greatly augmented during the last two years. As the railroads in Germany are used chiefly as military transports, many trackless-trolley lines have been installed between industrial centers, and vehicles propelled by single or double electric motors are employed, current being drawn from overhead conduits. When these vehicles reach the terminals of the trolley, they proceed to their destination under the power of the electric battery which they carry. Austrian reports state that the city of Vienna is about to adopt a policy of denying licenses to gasoline cars and granting them only to electricians. This city has particularly fine facilities for supplying electric current, and transportation will be fully as efficient as with the use of gasoline vehicles, as well as less expensive.

It is possible that developments in this country may necessitate the commandeering of gasoline vehicles. If the embargo which may be placed on the oil fields of Mexico is effective, or if the oil fields should be destroyed, England would have to secure petroleum elsewhere for fuel for her warships, which would not only greatly decrease the present supply in this country, but would also probably tend to make the cost of gasoline extremely high. The majority of large transportation fleets are composed of electric vehicles, and they would be of considerable value in supporting industrial activities. At least two of the largest central stations (electricity supply companies) have already tendered the government their fleets consisting of about 200 electricians.

The installation of electric industrial trucks in factories would greatly decrease the number of employes necessary, and materially increase the production. Experience has

shown that a battery-propelled truck driven by one man can accomplish as much work as five men using hand-drawn trucks and in less time. The worth of these trucks is plainly evident when it is realized that 10,000 electric industrial trucks would release 40,000 men, or nearly two full army divisions. It is a well known fact that at the present time practically all the employes of the factories abroad, including those which manufacture munitions, are women, and they are employing electric industrial trucks to a very large extent.

The New York police have already taken into consideration the possibility of War Department demands, and do not anticipate the experience of the Paris police, who were left with no vehicles when the government confiscated their trucks and patrol wagons early in the war. Four new electric patrol wagons and one which has been in service for some time are now ready for any emergency in New York City. The ten-year veteran electric has rendered such valuable service that they feel assured that they may rely on these vehicles to meet any emergencies.

In war time economy must be very carefully considered, and the electric vehicle completely meets all demands of urban transportation at the lowest operating cost, with the greatest efficiency.

### Lumber Production for 1916

A total computed lumber cut for the United States in 1916 of 39,807,251,000 board feet is announced by the Forest Service. This figure is based on reports received up to April 15, from 17,201 sawmills out of the 30,081 believed to have operated last year. It is estimated that the actual cut was slightly in excess of 40 billion feet.

In the following tabulation is shown the reported and computed cut by species, though these figures are subject to slight change.

#### Lumber Production by Kinds of Wood—1916

Kinds of wood	Reported Production M feet b. m.	Computed Production M feet b. m.
Yellow pine .....	13,377,465	14,975,000
Douglas fir .....	5,412,865	5,416,000
Oak .....	2,134,645	3,500,000
White pine .....	2,121,152	2,600,000
Hemlock .....	1,944,748	2,350,000
Western pine .....	1,679,917	1,690,000
Spruce .....	1,103,309	1,200,000
Cypress .....	943,063	1,000,000
Maple .....	790,071	975,000
Gum (red and sap).....	648,353	850,000
Redwood .....	490,828	490,850
Chestnut .....	411,006	525,000
Yellow poplar .....	382,686	575,000
Larch (and tamarack).....	376,076	440,000
Birch .....	357,023	450,000
Cedar .....	321,950	425,000
Beech .....	278,280	360,000
Tupelo .....	213,975	260,000
Basswood .....	205,294	270,000
Elm .....	191,923	235,000
White fir .....	189,579	189,660
Sugar pine .....	169,247	169,250
Ash .....	155,072	210,000
Cottonwood .....	133,879	200,000
Balsam fir .....	96,815	125,000
Hickory .....	92,376	125,000
Walnut .....	60,527	90,000
Sycamore .....	27,905	40,000
Lodgepole pine .....	26,888	31,100
All other .....	32,220	40,391
Total .....	34,369,137	39,807,251



**Single Seater Body to Carry Four**

The accompanying drawing represents a four-passenger single seat body, suitable for a Ford chassis, taken from the Coachbuilder and Wheelwright of Australia, where the coach builders build bodies for Ford chassis to a much greater extent than is done in this country.

One often hears motorists ask for a small body not out of proportion when used for one alone, with owner as driver, and yet suitable to carry two or three more, as occasion may require, also room for baggage. In other words, a single-seater to carry four passengers. This body is designed to meet these requirements.

The body is made to clover seat model with revolving back or boot seat and built below chassis, which is altered by substituting an angular radiator for the standard pattern, lowering the steering wheel to give 18 in. clearance between top of chassis and under wheel, putting in a new tank behind seat and built up as high as possible, and fitting new brackets or corner plates level with bottom

Two rails from section B to section C form sides of boot lid, which is also seat back. Back end of front seat rests almost on chassis. The desired rise can be given on front heel board, which is fastened to door shut pillars. When body is framed up as above, panels can be beaten and fixed, either turning edges over on top and bottom, so as to do away with moldings; or molding can be fixed if required.

It will be seen that the boot lid is built tapered. This is made so that when the lid is required for a seat back (it is revolved and slides down plates, as per drawing A, and rests on floor bottom), the lapping or fence plate to make lid waterproof would catch, so half the lapping is fixed to front half or lid and half on body. The lid is raised into an upright position before sliding, so on moving down the slide the lapping has clearance either side. The lid rests on section C, at top, is fixed in slide and rests on bottom, making a firm back. Of course, this is padded to form seat back. Care must be taken that the

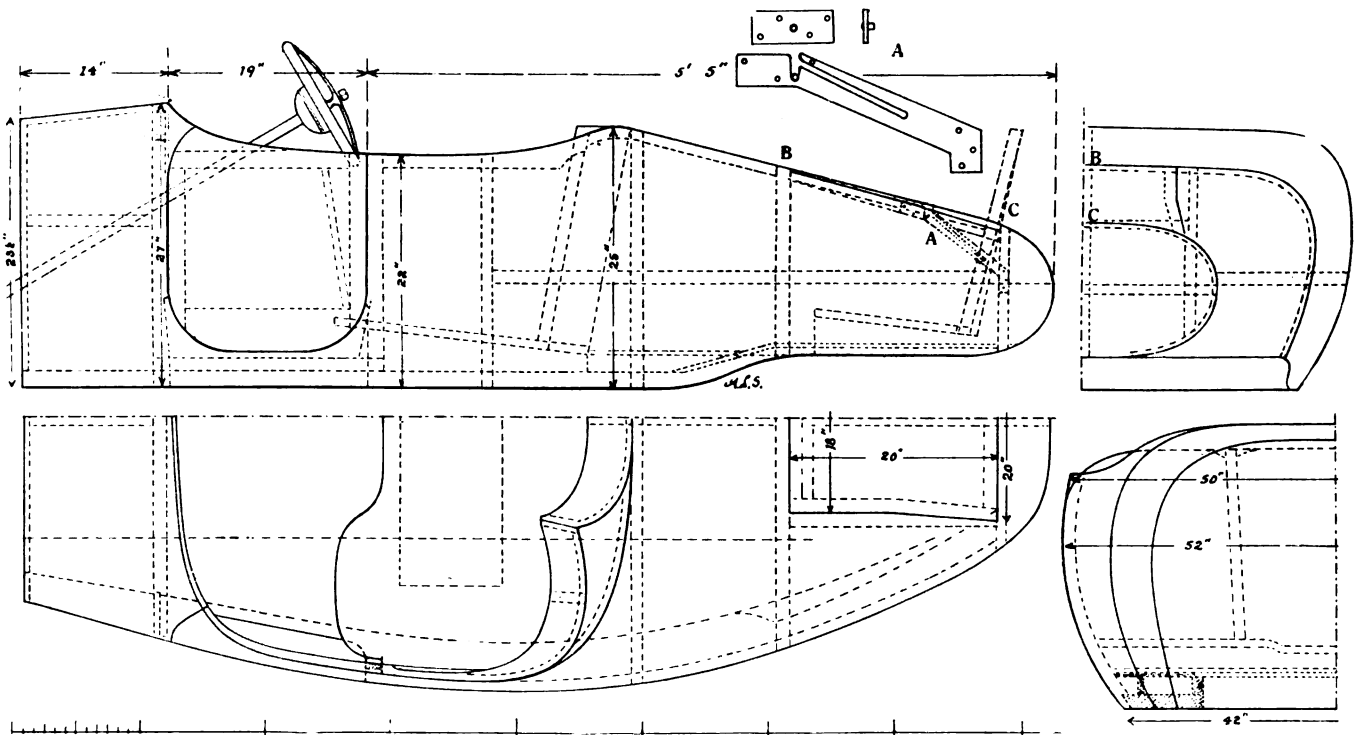

of chassis in place of old ones; also new fittings for front and hind mudguards.

The Body—Bottom framing is bolted to the new brackets. The rise commences first in front of the hind axle; this is to take advantage of hind cross bar of chassis, which projects out about 6 in. on either side. Body is built up in five sections, namely, scuttle, door pillars, seat back section, section B, and section C. These sections, when got out to drawings, form main lines of body. The clover seat is jointed to top rail (which makes a complete curve from door pillar to door pillar), and makes three curves and is fastened to pillars on the quarter and the two pillars in seat framing, the seat being got out to same curve as top rail. Doors and scuttle are made as usual. Front seat panels are fixed to the two standards or pillars in quarter behind doors, on which the seat back is fastened. Halved on to some standards are side rails which run round to section C, thus giving body side sweep. A rail runs from seat back section to section B in center.

slides are fixed perfectly square, otherwise the lid would fall out, so two uprights are fixed to floor and section C, to which back end of slides is fixed. The tail seat is built in on floor bottom, or can be made to take out if required.

**Technical School Closes a Good Season**

The Technical School for Automobile Draftsmen and Mechanics closed its day and evening classes for the winter term on April 11, after a very successful season.

The annual exhibition of drawings took place on April 17 and the rooms were crowded with interested visitors. The correspondence department is kept open the year round. The school is to be enlarged to meet the demand for men with training received there.

All inquiries regarding the school should be addressed to Andrew F. Johnson, instructor at the school, 20 West 44th street, New York City.

## Synthetic Rubber

By Andrew H. King

When the great chemist, Bayer, completed his synthesis of indigo and placed his process on a commercial footing, the indigo planters received a rude shock. They had been content to let well enough alone. To them the old way was the best way. They wanted no theorists about. They were practical men. The methods were old, time-tried, and unalterable. When things didn't go right they blamed it on God. Needless to mention there were many instances when something went wrong. The variation in their product kept the dyers constantly on the jump. Indigo sold at a high price, and the business amounted to something like \$25,000,000 annually.

It is no wonder that the planters felt secure. Indigo was a mysterious substance, could only be produced by natural means, and all the labor of the theorist was worse than useless. So they thought. Synthetic indigo was a man's task. It took Bayer 15 years to determine its chemical constitution and to synthesize it. To render its production a commercial possibility 20 more years were required. The Badische company spent millions of dollars. The first process, which started with toluene, was discarded because too little of this liquid was available. Finally, by accident, a way to convert naphthalene to phthalic acid was found, and another synthesis followed. Naphthalene is readily obtained from coal tar. It is consequently cheap, and the quantity is almost unlimited.

Synthetic indigo was soon in great favor. Its uniformity, its purity, and therefore its great strength made it much superior to the natural substance. It was cheap and increasing demand had but little effect on the price. Within a very short time natural indigo declined to almost a curiosity.

When the utilization of rubber became a business the demand for the crude gum sent the price up like a skyrocket. In 1910, which date may be taken as the beginning of modern rubber expansion, only 80,000 tons of crude rubber were produced. Of this quantity but 8,000 tons were plantation grown. 72,000 tons were wild rubber, and as variable in quality as can be imagined.

Here was certainly a field for the synthetist. With the remarkable success of Bayer as an incentive, organic chemists all over the world went to work. Forgetting the great expenditure of time, energy and money that the conquest of indigo required; the world expected immediate results. When these were not forthcoming many said it could not be done. Even today the opinion of many rubber chemists is that synthetic rubber is only of theoretical and scientific interest.

This may all be true, but if so it is only because the men who laid the foundation of plantation rubber well knew the story of natural indigo, and availed themselves of the botanist. They met science with science. By 1915 their yearly production was 146,000 tons, as against 8,000 tons in 1910. The ready demand for this rubber makes me wonder to what unknown figure this commodity would have risen if the old haphazard methods had not given way to science.

To date synthetic rubber has done remarkably well. The first step of any synthesis is to determine the structure of the material you wish to build up. Since rubber is a colloid its chemical structure is rather difficult to visualize. This has now been done with a reasonable degree

of certainty. Various methods of synthesis have been developed, which while they are very expensive have merit in that they actually produce caoutchouc. There remains only the commercial production. Our friends the botanists are making this more difficult every year. Still we have hopes. It is my claim that not sufficient time has elapsed, not enough energy been given to the proposition to yet justify its discard as unworkable. It, therefore, behooves us, as American chemists, to give thoughtful consideration to the matter. As a preparedness measure a successful commercial synthesis of rubber would be invaluable.

## Wide Use of Leather Substitutes

Nearly every city of any importance has had its 1917 automobile show. Impressions were made and various criticisms heard. Of course, everybody realizes that the motor car industry has progressed rapidly during the last five years, but few, except those interested in the business, know that there were 1,617,708 motor vehicles manufactured or put on the market in 1916. These alone had a value of over a billion dollars, without giving the accessories necessary to the car a thought, and every one knows that the purchase of the car is not the last cost.

While cars may differ in many other respects, they all have seats and same must be upholstered in something. That "something" will lead up to an argument any time. Some years ago all cars were upholstered in leather, but the great foreign demand for hides as well as the ever increasing shortage of same has put the price beyond the reach of the manufacturer of the lower price cars, hence the varieties of upholstery. Split leather in most cases does not prove satisfactory.

Seventy-five of the number of cars sold are known as standard cars and sell for \$1,000 or less. Of this number 60 per cent are being upholstered in substitutes. The reason of course being the acute scarcity of leather. The better grade of leather substitutes have all the usual leather qualities and more. They perfectly reproduce the beauty and luxury of the finest leather upholstery, and are in addition, grease and stain proof, as well as washable. Another big factor is that in place of varying lengths, widths, weights and thicknesses of leather, the substitute comes to him in rolls of standard length, width, weight and gauge. Instead of a wastage of from 39 to 40 per cent, as with leather, and the trimming out of hollows, bumps, weak spots and rough edges, he gets a material that is 100 per cent usable and of uniform strength, quality and efficiency throughout.

The substitute saves the manufacturer time, skill and money in purchasing because he knows beforehand just what he will get because it costs less than split leathers even though stronger. It saves time, labor and money in the factory, because it can be cut in large multiples by machinery and handled by less expert workmen. It insures a high class job of upholstering as it goes on smoothly, works easily and tufts beautifully, combining luxury, style and economy with an absolute guarantee of quality and service.

It is therefore well to study the upholstering portion as well as what may seem to be the more important parts of the car.

Auto Body Co., Lansing, Mich., has been compelled to operate night shifts.

Page of Interior Views of High Grade Custom Made Cars

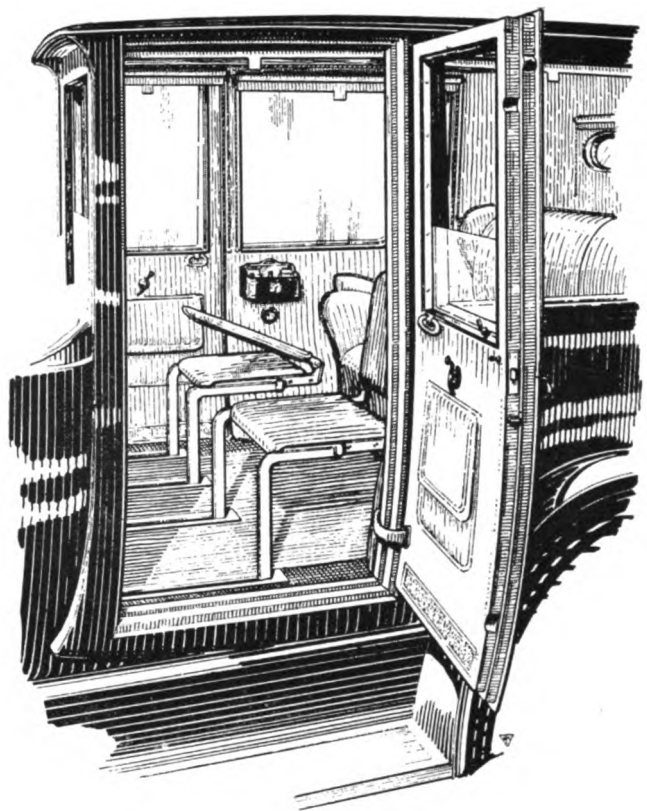
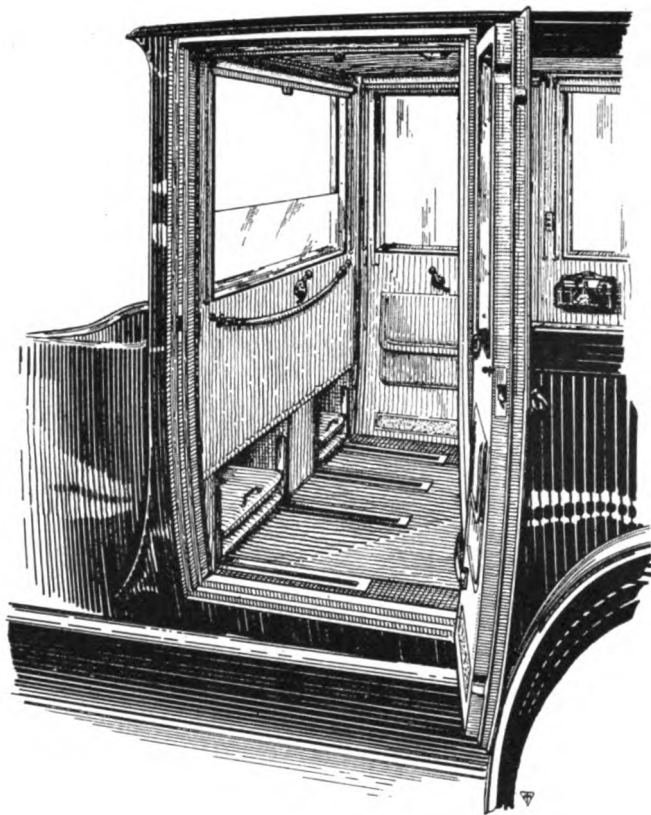

INTERIOR VIEWS OF BODY DESIGNED BY THE RUBAY CO., CLEVELAND

The one on the left shows the recesses in which the seats move and where the seats rest when folded, and the one on the right the seats in position when in use

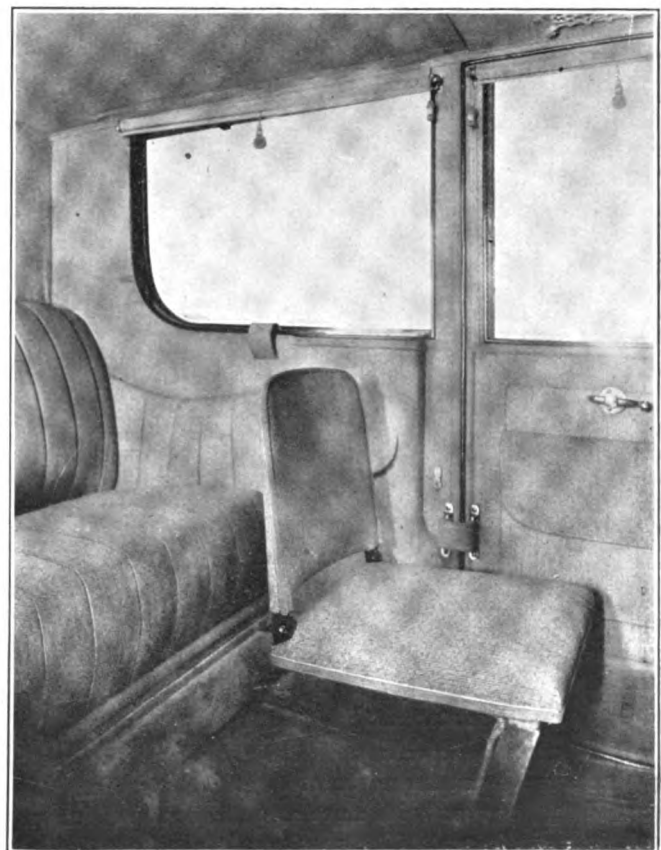
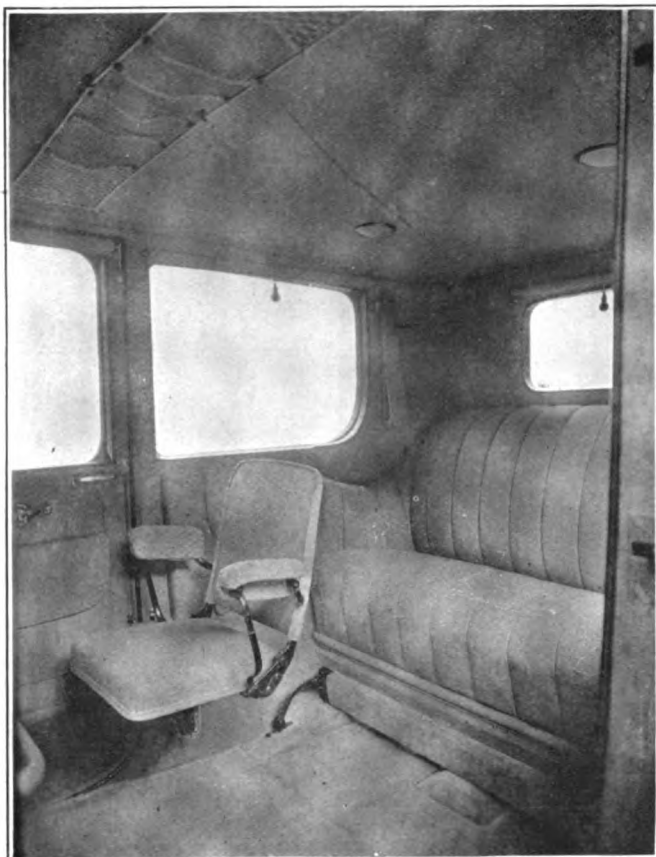

INTERIOR VIEW SEVEN-PASSENGER PACKARD LIMOUSINE

INTERIOR VIEW SIX-PASSENGER PACKARD LANDAULETTE

## Study of Body Room Has Led to Some Ingenious Designs

Car interiors are constantly being made better. In other words, the car is being made more habitable. When the car is occupied it becomes the temporary home of the passengers and everything which would tend to make these occupants more comfortable is a step in advance in the art of automobile design.

The importance of the proper proportioning of the body interior is not confined to the higher priced cars. It is a matter which affects every car whether it sells for \$500 or \$5,000. The touring car is affected as well as the sedan or limousine and it is a very interesting study to analyze the methods by which improvements have gradually been installed.

About three years ago the attention of engineers began to be diverted from the so-called streamline to the interior of the car. It began to be realized that it was perfectly possible for a car to have a perfectly designed exterior from the standpoint of beauty and yet be very uncomfortable in the interior. At about that same time wheel bases began to be lengthened out in order that the body manufacturers would have more room to provide the occupants of the car with the necessary space.

### Wheelbase Increased

The increase in wheelbase helped the situation to a considerable extent, but the trouble with this is that it caused the car to be considerably heavier, in spite of the fact that all the demands were for a car that would be lighter. With this in view it became very evident that merely lengthening the wheelbase would not suffice. While it provided more room it did not pay to increase it too far because of the loss in pick-up, due to increased car weight. The limit, therefore, in wheelbase increase was reached, and since that time cars have not been lengthened materially, although before 1915 it was almost a foregone conclusion that the car would be lengthened year by year.

The increase in block-cast engines in which the cylinders are all cast in one piece, cut down the length of the power plant materially and this tended to allow for more room in the body. Between the shorter engine and the longer wheelbase plenty of room has been secured but the question that remains to be solved is the scientific distribution of that space.

This question is more readily answered in the fine passenger car than in any other. There are simply two compartments each with a straight seat to be taken care of and hence it is quite simple to allow the proper amount for the passengers in the tonneau and the passenger and driver in the front seat.

With the seven-passenger car, the roadster or the sedan, which after the five-passenger car, are next in popularity, the problem is somewhat more difficult. In the roadster the question becomes one of seating the greatest number of people in the most comfortable manner and at the same time maintaining the more or less racy lines of the roadster. This has evolved some very ingenious schemes which at the same time produce bodies of great beauty.

### Roadster Should Be Narrow

A roadster to be correct must be narrow in the same way that a runabout motor boat should be narrow. The first roadsters or runabouts were made so as to seat three people in a single seat. The result was that these bodies were rather wide and could not be given the racy lines

desired. The next step was to produce something which seated the three passengers and allowed the body builder to keep the desired narrow lines. It was natural that with this in view the cloverleaf roadster and the staggered seat roadsters should be evolved. The cloverleaf, of course, has the seats in the form of a three-leaf clover. The staggered seat has the driver's seat somewhat in advance of the other seat which holds two people.

On the seven-passenger car concealment of the extra seats has given a wide field for inventiveness. Some are in the back of the front seats, some under carpet, and others merely fold to one side, and finally the others, and the latest scheme, is to fold them back under the rear seat. These schemes all have their advantages, and once the spare seat problem is solved the matter of arranging space in the seven-passenger car is no more difficult than in a five-passenger. A point which has not been as well worked out as it might be is that in some of the spare seats used in seven passenger cars, the occupants became very tired after a long drive because of the rigidity of the seats and the want of depth in the upholstery.

The sedan is really the car of comfort. There are a great many more experienced motorists each year who favor them for touring. Some ingenious schemes for making sleeping cars out of them have been brought forward. With a car of this kind the venturesome motorist is free of hotels and can go where and when he pleases. He is as comfortable as he would be in any tent. This plan of gypsy motoring is increasing and is a healthy and wholesome sport.—Merle Shepard, in N. Y. American.

## Carriage Builders' National Association Convention

Office of the Secretary and Treasurer

Mount Vernon, N. Y., May 1, 1917

To the members of the Carriage Builders' National Assn.:

The forty-fifth convention and exhibition of the Carriage Builders' National Association will be held in Chicago, Ill., from September 24 to 27, 1917.

The exhibition from September 24 to 27, inclusive.

The convention—September 25, 26 and 27.

Both the exhibition and convention will be held in the Hotel LaSalle, Chicago.

The committee expects to arrange for the meetings in such a manner and with such subjects that the whole carriage trade will be both instructed and benefited. We expect this to be one of the very best of our conventions.

You are earnestly requested to arrange to be present; you will surely be repaid for your time and expense.

By order of the executive committee.

HENRY C. McLEAR, Secretary.

## Plans for Ford's New Jersey Plant

The Ford Motor Co., 1723 Broadway, New York, has perfected plans for its proposed automobile plant on property recently purchased in the meadow section, Kearny, N. J., fronting on the Passaic River. It is said that the plans provide for the erection of five four-story buildings to form the initial plant, each structure to be about 325 x 1,400 ft. Work has commenced on the construction of a bulkhead 1,000 ft. long. A seven-track terminal will be established at the site by the Central Railroad of New Jersey. The entire project is estimated to cost in excess of \$1,000,000.

# Progressive System Used in Chalmers Plant

The progressive assembly system, to those interested, is more or less well understood, but any who have not seen it in operation can not by any stretch of imagination conceive of the effectiveness of such a method, or its wonderful efficiency and the remarkable economies effected through its adoption.

A most direct result of the establishing of the progressive assembly system in the factories making both high and moderate priced cars, as well as in those manufacturing the lower priced vehicle, is noticeable in the reduction of the selling price to figures said to be less than a third of what would have to be charged were the economies effected by this method impossible of attainment. It is also responsible for the increased rate of wages paid mechanics in these factories. It is this system also that has brought quantity of production to such a high figure that motor cars are now within the reach of thousands that might otherwise never become car owners.

Marvelous is an apt word to use, for one who witnesses the operation of a modern progressive assembly system in one of our large motor car manufacturing plants; for one cannot help but marvel at the accurate, time-saving, and supremely efficient manner in which the various stages of the work are taken up and advanced and finally delivered in a completed state at the end of the chain, as it might be called. The accompanying photographs illustrate the progressive system in use at the factory of the Chalmers Motor Co. This company is said to be the first manufacturing a moderate priced line of cars to adopt the

system. The conveyor on which the assembly progresses is 800 feet in length; this chain is endless and when it swings through at the lower end of the first floor a bare frame is placed upon it upside down. The running board, supports, mud pan and braces are riveted to the frame and the springs and axles are attached at this point. As the chain moves on the chassis is carried into the spraying compartments, where it receives a coat of paint on two sides in rapid succession. It next passes to the baking oven and then to a point at the other end of the building, where the wheels are attached.

The chassis is then carried to the second floor, where the next stage of the assembly is effected. This shifting from one floor to another is accomplished by a device, or apparatus, known as a "ferris wheel," driven by an electric motor. This "wheel," which is actually a square, takes hold of the chassis, which is in an upside down position, and simply turns it right side up by the time it reaches the second floor. The illustration shows plainly how this is possible, the wheels running in tracks that are flanged, around the loop. When the chassis reaches the floor above it is resting again on a conveyor chain. Here the power plant is swung into position and bolted fast. The chassis now appears more nearly like an automobile and is soon fitted with fenders, steering wheel and radiator. Then it is ready for the placing of the body, which is lifted into place by an overhead crane. All of these parts are brought into place and attached in very little time, and the top and side curtains also attached. The car

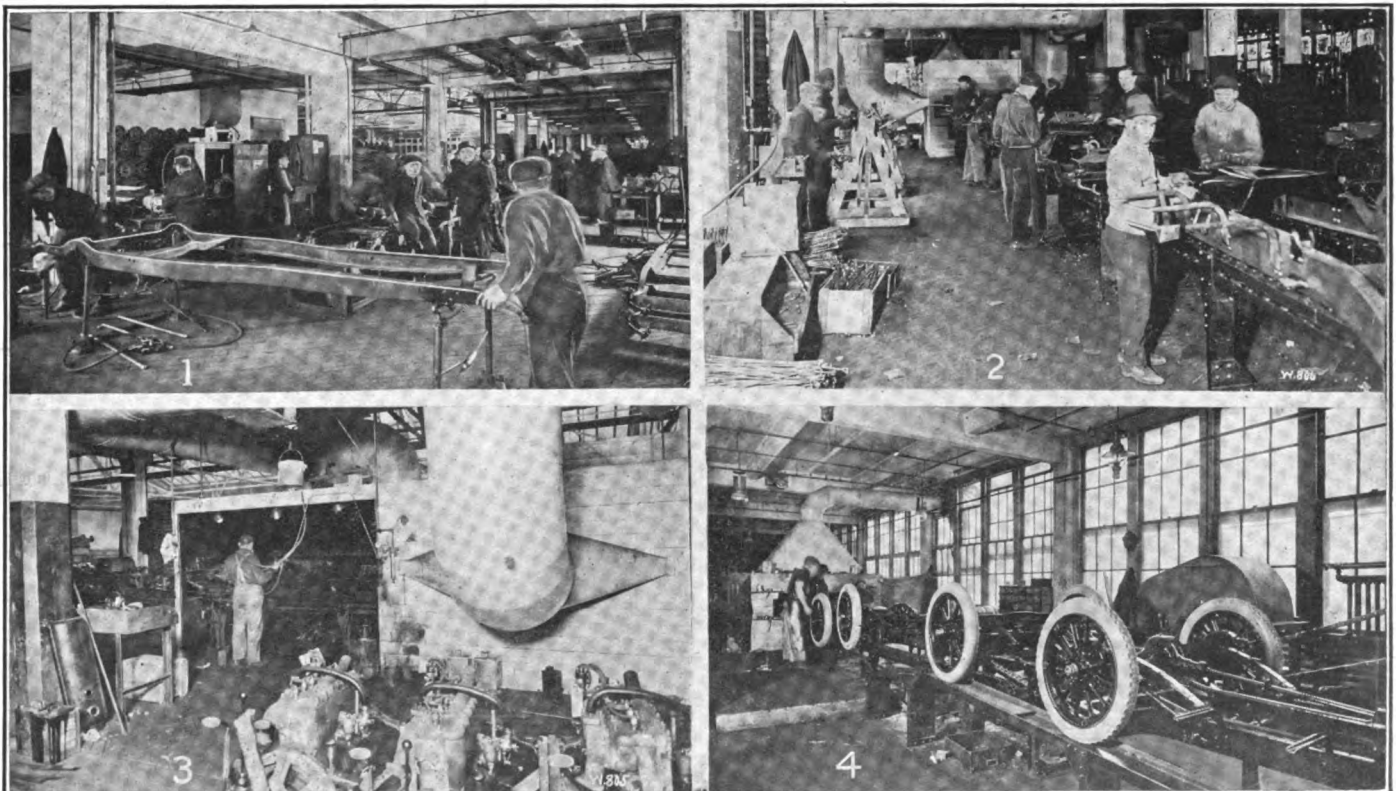

1—Placing rivets in frame at start of conveyor system, Chalmers assembly. 2—With frame upside down, springs, running boards, brackets, etc., are attached. 3—Painting the chassis at entrance to baking oven. 4—Wheels attached, chassis still reversed



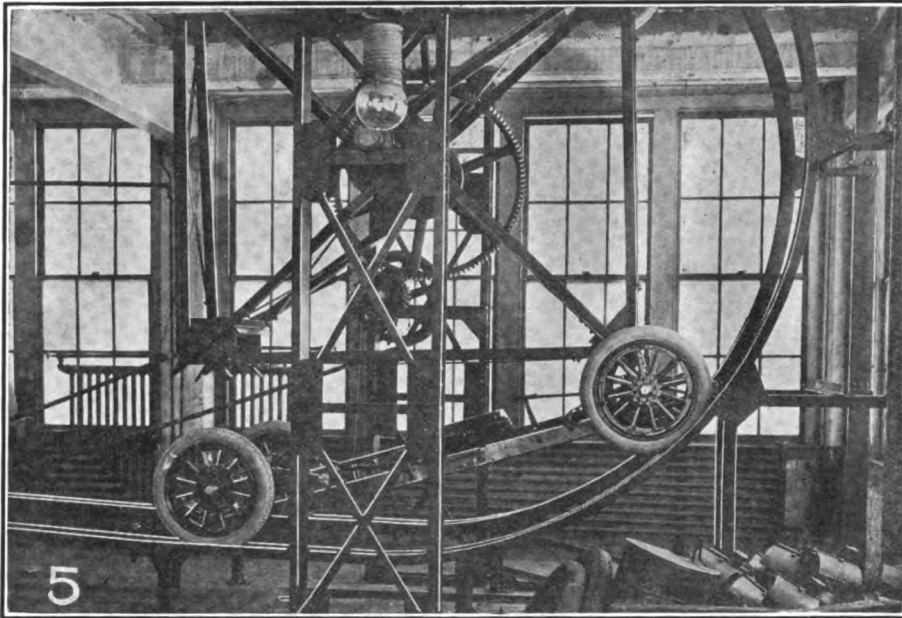

5 Chassis lifted to second floor and to upright position by Ferris wheel device

is then practically complete, and after passing inspection is taken to the shipping point, or platform, under its own power.

Passing the chassis frame along in the upside down position enables the assemblers to work on it in a standing position, and greatly facilitates the work thereby, as the working conditions are most advantageous. The only time that any work under the car becomes necessary is when the body is attached, but the provision of pits for the men to work in makes it possible for them to stand erect when placing the bolts and this also greatly accelerates the work of assembly at this stage.

The time consumed in assembling a car complete, from start to finish, is about three hours, and 100 cars per day are now being turned out.

This same system with some modifications and different setting and with widely varied speeds, is used in the large plants where the low priced cars are made, and also in their assembly branches in different cities. At Indianapolis one of the branches has been turning out 150 cars every eight-hour day with 35 assemblers, while at Long Island City another assembling plant builds 165 cars every eight-hour day with 55 men. The Indianapolis assembly means a completed car every two minutes and 12 seconds. Not allowing for the time the cars are in transit from one workman to another in some shops its pause is little less than  $3\frac{1}{2}$  seconds at each stop.

A description in words of the efficiency of this really marvelous system does not suffice to give the uninitiated a true conception of what it is. Only personal inspection can bring to one's mind an idea of the extensive thought and labor that has been expended in creating this seemingly impossible institution, which has revolutionized methods of making machine products. It has done away with the "jack-of-all-trade" and his inefficient methods. Each man does one thing over and over again. He is proficient in that specialty, can do it quickly and always with the least possibility of error. There is less overseeing necessary, less confusion in the factories and less lagging

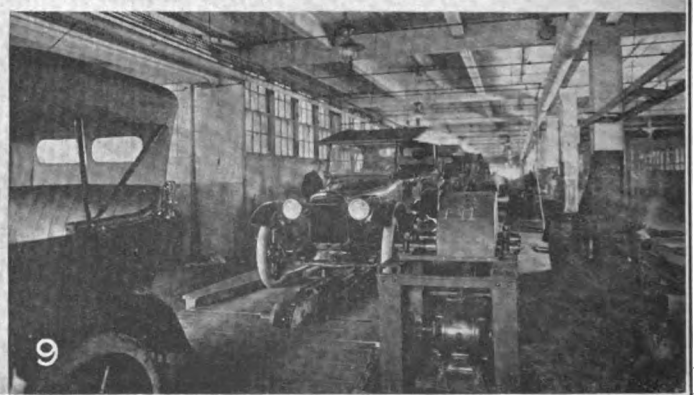
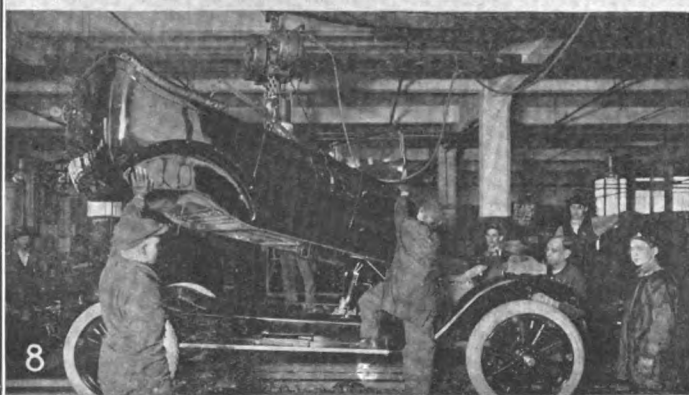
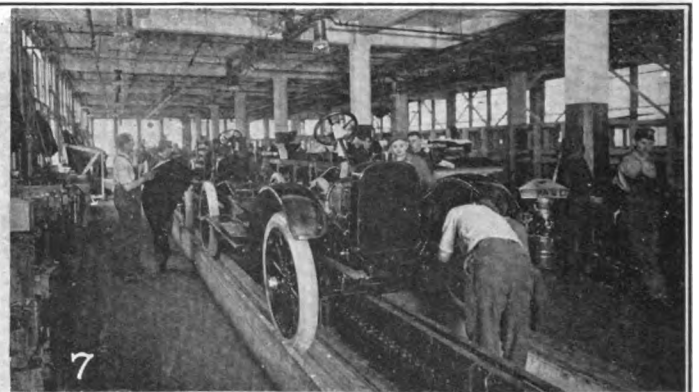

6—Chassis, now on second floor, receives power plant. 7—Putting on fenders, radiator, etc. 8—Body Installation. 9—Car run off conveyor chain on own power, passed by final Chalmers Inspectors and ready for shipment



as a man's work is put right in front of him. It does not wait until he decides to take it up, but automatically comes in front of him and must be done immediately and quickly, as he is a cog in the slowly turning wheel, hence, unless he moves the whole apparatus and organization is thrown out of tune.

Progressive assembly did not originate in the automobile industry, but when the geniuses that built up this business undertook to adapt it for their own purposes they found many difficult problems for solution that had not been encountered by pioneers employing the method.

It seems that it is the last word in economizing on the production of automobiles, although it is understood that one manufacturer has already conceived a method of handling his raw materials that will effect a big saving on his cars.

### **M. A. M. Adopts Group Organization Method**

The April monthly meeting of the Motor and Accessory Manufacturers was the most important ever held by the organization. It was not only decided to co-operate on an extensive scale with the Council for National Defense and a committee appointed for that purpose, but it was voted to inaugurate a new system of administering the activities of the organization along lines developed by L. M. Bradley, general manager.

E. H. Broadwell, vice-president of the Fisk Rubber Co., was appointed as representative of the M. A. M. on the Council for National Defense at the suggestion of Howard E. Coffin.

Ninety-five per cent of the members voted their approval of putting in force the "grouping" method of handling the organization's activities on lines similar to that followed out in the work of the S. A. E., different groups being formed of men manufacturing similar lines under such heads as engines, tires, rubber, electrical products, axles, wheels, bearings, bodies, gears, carbureters, springs, steel and similar divisions.

The grouping system will be worked out by a committee composed of E. W. Stiger, of the Stromberg Motor Devices Co.; W. R. Rutherford, of the B. F. Goodrich Rubber Co., and L. M. Bradley, general manager of the association.

It was also decided to expand the credit department, which has become one of the most important departments of the organization. Expenditures of \$10,000 or more additional in this work are planned and in addition to the regular reports that are now furnished on manufacturers in the trade reports, will also be given members on airplane, motorcycle and bicycle makers. A new credit committee, composed of credit managers of the member companies has been appointed to carry out the credit work in conjunction with the finance committee. This committee was made up of the following: R. D. Mock, treasurer of the Hydraulic Pressed Steel Co.; F. R. Wilhelmy, assistant treasurer of the Standard Parts Co.; R. M. McConnell, credit manager of the Firestone Tire and Rubber Co.; M. C. Dittman, secretary and treasurer of the American Bronze Co.; G. H. Johnstone, credit manager of the Armour Curled Hair Works; M. A. Moynihan, secretary and treasurer Gemmer Mfg. Co.; R. S. Preble, treasurer Splitdorf Electrical Co. The meetings of these committees will be held at the discretion of the members, probably every six months or quarterly.

The annual meeting in New York City during the Na-

tional Automobile Show week will be continued and in addition it was voted to hold mid-season meetings, the first of which will be held on September 12, 13 and 14, at Atlantic City.

The following firms were admitted to membership at the meeting: Standard Steel Castings Co., Cleveland, O.; Standard Woven Fabric Co., Walpole, Mass.; Jackson Cushion Spring Co., Jackson, Mich.; Jacobson Machine Mfg. Co., Warren, Pa.; National Malleable Castings Co., Cleveland, O.; Merchant & Evans Co., Philadelphia, Pa.; Weston Electrical Instrument Co., Newark, N. J. The Standard Roller Bearing Co. and the Armour Curled Hair Works were reinstated to membership.

### **To Boom Electric Vehicle**

At a meeting of electric car and truck manufacturers in New York City on April 9, steps were taken to secure concentrated action by the entire industry for a national educational campaign.

They adopted, for recommendation to the Council of the National Light Association, the proposal for giving new life to the electric vehicle industry made by E. P. Chalfant, manager of the eastern division of the Anderson Electric Car Co., which is as follows:

1. All divisions of the industry to raise a fund to engage an experienced man to take charge of the propaganda, working under electric vehicle makers. Yearly cost about \$20,000, manufacturers to pay \$1,000 each, and balance of 25 per cent to be supplied by central stations through N. E. L. A.

2. A booklet to be prepared for distribution to the central stations, setting forth the history, potentialities, and possibilities of the electric vehicle business, and explaining to the central stations how they can co-operate through advertising and spreading information.

(a) Methods employed and suggested for use by the central stations.

(b) How a man employed by a central station might co-operate.

(c) Specimen advertisements advertising the industry and not any particular car.

(d) Complete information regarding electric apparatus and its operation and sale.

(e) How central stations can co-operate with dealers and garagemen.

(f) How boosting stations may be installed.

(g) Why central stations should have an electric vehicle department.

(h) Information to central stations as to what has been done in large cities regarding parking facilities.

(i) How a booklet can be prepared for distribution to car owners, showing the location of garages and charging stations in the city and surrounding country.

(j) Battery exchange methods now successfully used and how they operate.

(k) Recommendations that central stations insist garagemen in getting together to establish uniform methods.

3. Central stations to be made familiar with the value of electric vehicle charging as an off-peak, long-hour, low-demand department of their business with a possible view to rate revision.

In addition to the electric car and truck makers, manufacturers of industrial trucks, batteries, tires and accessories were represented at the meeting.

A paper by G. D. Fairgrieve, vice-president of the

Anderson Electric Car Co., on advertising and publicity, advocated inducing central stations to co-operate with electric vehicle manufacturers in advertising current for vehicle use just as gasoline and oil companies advertise their products for gasoline car consumption.

E. P. Chalfant read a paper on What Co-operation Means, covering financial, physical and educational phases of the subject.

C. A. Street, Walker Vehicle Co., stated that the charging problem in electric vehicle selling is a small one, as he has always found central stations ready to install charging apparatus in garages on request.

Chairman Mansfield pointed to the rapid increase in the utilization of electric industrial trucks and predicted realization of much greater opportunities in this field in the future. Electric vehicle manufacturers get best results in distribution by selling through dealers, according to the paper on Distribution by P. D. Wagner, president General Vehicle Co. Mr. Wagoner approached the distribution and sales problems of the electric vehicle manufacturer, with special reference to commercial vehicles, from every angle.

### April Meeting of the Carriage Makers' Club

The April meeting and dinner of the Carriage Makers' Club took place on the evening of the 12th at the Business Men's Club, Cincinnati, and was attended by 50 members.

The committees for the past year made their reports and all were tendered a rising vote of thanks. The press committee especially was praised for its efforts. The publicity the Cincinnati Carriage Makers' Club received during the year was highly appreciated. The various trade journals were also thanked.

The principal speaker of the evening was Richard Crane. His subject, "The Verdict of Common Sense," was full of patriotism. He deplored modern tendencies toward Socialism and materialism. "Socialism," he said, "never has solved any problems with which America has to deal, and the differences between capital and labor will only grow less when men learn to respect the rights of others." He advocated a democracy that shall include all countries and declared the tide is setting toward a United States of Europe. He paid tribute to the German-Americans for their efforts in behalf of this nation during the Civil and Spanish-American Wars, and added that they have never been missing when Uncle Sam needed them.

The following new officers were installed by Retiring President Charles A. Fisher: President, H. H. Nelson, American Carriage Co.; first vice-president, Howard S. Cox, Kelly-Springfield Tire Co.; second vice-president, W. S. Rulison, W. F. Robertson Steel & Iron Co.; secretary, W. J. R. Alexander, Wright Varnish Co.; treasurer, E. E. Hess, Sayers & Scovill Co. Board of governors: E. M. Galbraith, Anchor Buggy Co.; Emil Hess, Sayers & Scovill Co.; Harry McBride, Carnegie Steel Works; W. J. R. Alexander, Wright Varnish Co.; Theodore Luth, Luth Carriage Co.; H. S. Cox, Kelly-Springfield Tire Co.; H. H. Nelson, American Carriage Co.; W. S. Rulison, W. F. Robertson Steel & Iron Co.

Treasurer Hess reported the organization as being highly prosperous, having \$400.91 in the bank.

The scrap book, which is a part of the work of the press committee, came in for commendation. The clippings attached to the pages afford an excellent record of the

business history of the trade as well as the club. This year's book contains pictures of all of the members of The Carriage Makers' Club, or at least the majority of them, and pictures of all of the presidents of The Carriage Makers' Club and some faces of yester-year, which are very interesting.

P. P. Hunter was appointed custodian of the club's official scrap book and the minute books of previous years.

The guests present at the meeting were L. C. Fehring, of The Fehring Carriage Co., Columbus, Ind., and C. W. Porter, of The George Delker Co., Henderson, Ky.

### St. Louis Vehicle Association

The regular monthly meeting of the Implement, Vehicle and Hardware Association was held at the Planters Hotel, St. Louis, on Monday evening, April 16.

Emil N. Tolkacz, director of public works of the city of St. Louis, the speaker of the evening, told an interesting story of the public institutions, parks and public works of the city. Several matters of interest to the farm tractor industry were discussed.

An invitation was received from the conventions bureau, asking for a committee on reception to entertain members of the Associated Advertising Clubs of America, which meets in St. Louis early in June.

Frank E. Goodwin, editor of Farm Machinery-Farm Power, and chairman publicity committee of the Mississippi Valley Implement Dealers' Association, explained in detail the plans which have been worked out to enlist 1,000 new members in that organization.

The next meeting of the association will be held May 21. The entertainment committee consists of W. S. Roberts, manager of J. I. Case Threshing Machine Co., and Geo. P. Weber, Jr., secretary Weber & Damme Wagon Co.

### Electric Apparatus Men Organize

Manufacturers of electrical apparatus used in the automotive industry have formed the Automotive Electric Association, meeting for the purpose at Atlantic City, N. J. G. Brewer Griffin, of the Westinghouse Electric & Mfg. Co., East Pittsburgh, Pa., is president of the new association; C. O. Mininger, of the Electric Auto Lite Co., Toledo, O., is vice-president; G. S. Cole is secretary; and C. L. Amos, president of the Dyneto Electric Corp., is treasurer. The organization proposes to undertake standardization of electrical appliances and other activities that are possible to an organization of its kind. The next meeting is scheduled for May 17, 18 and 19, at Hot Springs, Va.

### Comparing Leather Costs

The comparing of costs of a standard leather quartered top buggy, based on the cost of material today as compared with the cost of the same vehicle in January, 1916, brought out some very interesting facts at the special meeting of the Carriage Builders' National Association held in Cincinnati, March 28, and strange to say there was quite a variation in these prices, the cost of labor and material varying from \$2.50 to \$6 on the same job from different manufacturers. It was found that a great many manufacturers had compiled their costs from stock that was bought prior to January 1, 1917, and that a great many costs were not based on the market prices of today.

**Ford Bodies**

The bodies shown in the illustrations are for light delivery purposes, and to be mounted on a Ford chassis. Fig. 1 shows a closed body with plain panel sides, and molding trim as shown, giving a more finished appearance to the body.

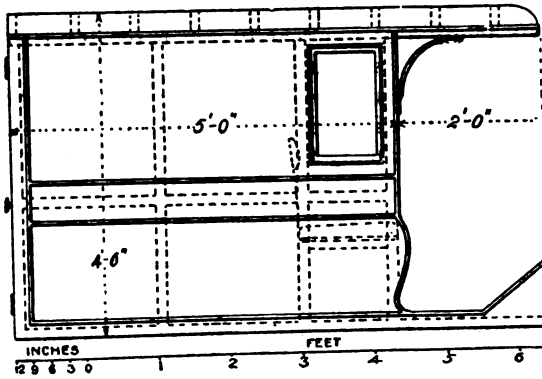

Fig. 1

The driver's seat has a lazy back which can be dropped down so that if so desired the driver can enter the body from the forward end. There are two hinged doors at the rear of the body to permit loading and unloading of the body.

Fig. 2 shows an open body with a tail gate, and side flare boards, as well as a driver's cab, which adds much

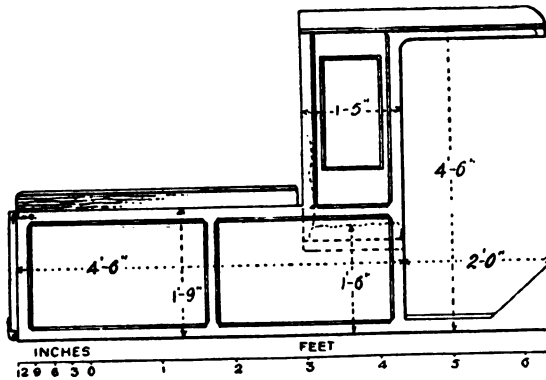

Fig. 2

to the appearance of the body. This body design will be found very useful to the building contractor, as well as to the farmer. These body designs are not expensive to build, and will carry from 700 to 800 pounds merchandise.—The Blacksmith and Wheelwright.

**Swedish Crucible Body Series**

The Swedish Crucible Steel Co., of Detroit, is manufacturing the following series of bodies for Ford and other chassis:

For merchants who desire an enclosed type of body a number of choices are offered. The first style is designed with curved lines, the sides are swelled and paneled with one section above, five below and fore doors. The upper, main panels are made of 3/8 in. white wood, the lower, metal and reinforced inside with wood sheeting. Oval plate glass windows are provided at the side of the driver's seat and in the upper panels of the rear doors. This body is 44 in. wide, 60 in. long back of the seat and 55 in. high, all inside dimensions. The second style is designed with straight lines and comprises six different bodies. The

first is made of 20 gauge anti-rust automobile body steel panel, with hard wood frame, and has one large and small panel above, and one long panel below. This body is also provided with glass driver's windows, and rear door windows, and measures 43 in. wide, 56 in. back of seat and 56 in. high, inside. The second is 3/8 in. white wood panel and designed similarly to the first, with the exception that the top panel extends the length of the body. This model is also equipped with windows, but is not fitted with fore doors. The inside measurements are 44 in. wide, 60 in. long back of seat and 55 in. high.

The third is also wood panel, one above and five below, with square, rather than oval windows. This body has no fore doors and measures 43 in. wide, 60 in. long back of seat and 55 in. high.

The next two styles are wood panel, one above and four below, oval windows and furnished with or without fore doors. The inside dimensions are either 43 or 44 in. wide, 60 or 72 in. long back of seat and 55 in. high.

The sixth is much larger than either of the other styles measuring 48 in. wide, 66 or 72 in. back of seat and 56 in. high. This body is built of 20 gauge steel panel, without fore doors.

An open express four-post curtain side body, made entirely of oak floor boards running lengthwise and protected with steel strips, is designed for the merchant desiring an open type of body. This type is made in four sizes, 44 x 84 in., 44 x 96 in., 44 x 102 in. and 44 x 108 in.

For the Ford extended chassis two different styles of stake bodies are carried. One narrow to fit between the wheels, giving a low loading platform, the other a wide body raised sufficiently high to clear the wheels when loaded to capacity.

Two types of undertakers' bodies are made, both of 3/8 in. white wood panel, with fore doors extending to the top and fitted with drop sash windows and clear vision windshield. These bodies are 44 in. wide, 90 in. long rear of seat and 57 in. high inside dimensions, fitted with rollers and stops, neatly upholstered and ready for the chassis. The first type is equipped with side plate glass windows, the second is plain panel.

**Design as Affecting the Future of Trailers**

It has been the experience of nearly two years of building trailers that there are some very important details to consider in relation to the future of the trailer industry, writes C. M. Beer, of the Emerson-Brantingham Imp. Company.

With any old two-wheeled cart with a pole attached to it and shackle of some kind to hook on to the back end of an automobile, it is plain to be seen that the trailer will fall short of the expectations of the purchaser and the trailer business will be given a black eye, so to speak.

Designing a trailer to meet the hard usage to which it is necessarily placed in following the automobile and carrying a load requires no little experience in vehicle construction. Not only must special wheels and axles be provided, with abundant capacity for lubrication, but the relation of the load to the axle must be given careful consideration.

That portion of any vehicle below the springs, the unsprung weight acts as a hammer and pounds not only the road over which it travels but the body and weight it is carrying. The shock of the bound as the wheels strike a rough place in the pavement is exactly equal to

the rebound which is communicated to the body of the vehicle. Springs are used to absorb the sudden vibrations produced by shocks and prevent them from unduly jarring the trailer and the contents that is being carried.

Now many vehicles are constructed so that the provision for an impact of meeting an obstruction is all perpendicular. That is, the throw of the springs and the way they are attached to the axle provides only for shocks that are directly perpendicular. In reality there are no perpendicular shocks on a wheel. The shocks all come forward, as you may easily see, when you imagine a wheel striking a 6 or 8 in. obstruction. As the vehicle is pulled along over this obstruction the shock is considerably forward and has a tendency, instead of closing up the spring, to tip the forward end of the spring downward, therefore the heft of the spring and the attachment to the axle should provide for these forward impacts. We see on some well designed automobiles springs with the front end of the arc elevated two or three inches above the rear end of the spring better to meet the road obstructions at a right angle to the springs throw. This principle must be given ample consideration in the auto trailer.

Another very important feature of the trailer is the hitch. Not only must the hitch be simple and easily adjusted to any height of automobile, but it must be strong and free from rattle and a noiseless shock absorbing arrangement is necessary in the pole to make it handle so that it will not permit a too sudden jar to come upon the rear axle of the machine in starting and stopping, and also to prevent disturbance in the load that is being carried or possibly racking of the same.

These various features of trailer construction will have a great deal to do with the future of the auto-trailer as a serviceable and convenient adjunct to the automobile.

### **Russel Motor Axle Buys Russel Gear**

Purchase of the gear plant of the Russel Wheel & Foundry Co. has been authorized by the stockholders of the Russel Motor Axle Co., North Detroit, Mich., who at the same time approved the increase of the capital stock from \$250,000 to \$600,000, and the declaration of a 100 per cent stock. The wheel and foundry plant has been virtually a Russel property, ownership of the two companies being nearly identical. A. W. Russel, president of the Russel Motor Axle Co., is treasurer of the wheel and foundry company; W. S. Russel, president of the Wheel & Foundry company, is vice-president of the Motor Axle company; John R. Russel is secretary of the Wheel & Foundry company, and George B. Russel secretary and treasurer of the Motor Axle firm.

### **Ice Cream Truck Bodies**

A New Jersey ice cream manufacturer is operating 12 electric trucks. An interesting feature of this installation is the waterproof construction of the truck bodies which successfully prevents the salt water from coming in contact with the running parts, thereby eliminating considerable trouble. Tar paper was laid over the flooring of the truck crosswise, each strip being carefully lapped over the next one. This tar paper was run up the front and sides of the truck to a height of about 6 in., and all the seams were carefully filled in with tar. Galvanized sheet metal was then fastened to the front and sides of the body to a height of 36 in. lapping over the tar paper near the

floor. A wooden flooring was then placed over the tar paper running lengthwise with the body. At the front end of the body two  $\frac{3}{4}$  in. holes were drilled and pipe nipples were inserted. A length of rubber hose connected with these pipe nipples and projecting down to about 6 in. from the ground drains off the brine solution so that it does not come in contact with any of the metal parts. The salt solution at the rear of the body drains off the tailboard which is always carried down. This is an important as well as an interesting feature because the delivery equipment of an ice cream manufacturer usually depreciates more rapidly than the equipment of any other business.

### **Aircraft Makers Ask Help of Materials Manufacturers**

The Aircraft Manufacturers' Association desires to get into communication with all manufacturers of finished products and producers of raw materials entering into the construction of aircraft of all descriptions. It desires among other things samples of steel tubing, leather, aluminum, turnbuckles, aviators' wire, and catalogs of fittings, instruments and equipment of every sort. All communications, samples and data relating to the above materials should be addressed to the Aircraft Manufacturers' Association, 501 Fifth avenue, New York.

The association is composed of the following: Aero-marine Plane & Motor Co., 1881 Broadway, New York; L. W. F. Engineering Co., College Point, L. I., N. Y.; Standard Aero Corp., 1381 Woolworth Building, New York; Sturtevant Aeroplane Co., Jamaica Plain, Boston; B. F. Sturtevant Co., Hyde Park, Boston; Thomas-Morse Aircraft Corp., Ithaca, N. Y.; Cutriss Aeroplane & Motor Corp., Buffalo, N. Y., and the Burgess Company, Marblehead, Mass. Howard E. Coffin, Council of National Defense, Washington, D. C., and Sidney D. Waldon, Aircraft Production Board, 541 Munsey Building, Washington, are honorary members.

### **Nicaragua Good Market for Automobiles**

There is a good market for a medium-priced American automobile in Nicaragua, according to Dionisio Villa V., a manufacturers' representative in Leon, that country, who is seeking to establish a profitable agency for some automobile manufacturer in that territory. Preferably the car should be of 124 to 140 in. length over all, of 56 in. tread, well powered for hilly country, and with parts protected from dust. Villa is now representing, among other concerns, the Remington Typewriter Co., the Mosler Safe Co. and the Aeolian Co., and his dealings in New York City are carried on through G. Amsinck & Co., 9 Hanover square.

### **New Demurrage Rates**

New demurrage rates were put in effect May 1 to take the place of the emergency rates prescribed by the interstate commerce commission December 1 to govern until May 1. The new rates provide for two days' free time with a charge of \$2 per day for four days and \$5 for each succeeding day. This represents but a slight change from the emergency rates, but it is an advance of 100 per cent over the rates which prevailed to December 1.

## Paint and Varnish

### Varnish

The house painter knows that the public often says, "That's splendid paint, it's dry already." But the painter knows that it won't look splendid long. Dryers burn, perish, destroy the life of paint (and varnish) when too much is used. One pint of terebene dries 16 pints of raw linseed oil. Remember red lead is a dryer by itself: so is Turkey umber, but it is erratic. Turpentine has some effect as a dryer; benzine has none, that is why varnishes made on a benzine basis dry slowly. Unless an excess of dryers is added then they "go to pieces." You have seen the white, powdery, perished varnish on an old piano box panel. That is either white copperas or the sugar of lead that the varnish manufacturer introduced to make his varnish sell. So many coach builders want a varnish that they can put on a job this afternoon and deliver the job tomorrow. The durable varnishes are slow drying varnishes, and are safe.

Pinholes are sometimes caused through draughts or through undercoats being insufficiently dried, but not always. The cause is often through the dryers boiled in with the varnish being moist, viz., undried sugar of lead. For an experiment you can, by increasing the dryers, increase the pinholes into patches like blotches. Too much dryers in varnish renders it unfit for delicate colors. The pale, slow drying varnishes are used by the best painters on the best work. The varnish that is an over-night dryer is for common work.

In making varnish the quality of the turpentine is very important. It must be aged. When turps is left in open lead tanks it thickens, and improves, and as a dryer becomes more energetic. Again, "pinholes" are often caused by the pyroligneous, or wood acid in turpentine which has been drawn from green trees. The best varnishes are made without dryers in the oil, which is boiled until it is known as standoil.

A finished varnished panel should be like looking into deep water or into a highly varnished mirror. Failure in varnishing is often attributed to an unsuitable shop, but it is often caused through want of care, in flattening with pumice power. Don't trust to the water tool. Flat with less water. Don't flat the obscure places. Regarding pumice power, bear this in mind: "It is easier to keep it out than to get it out." Motor painters don't use as much water in flattening as coach painters do, that is why their work looks full and clean.

### Gold Leaf

Gold leaf is dear, and careful gilders avoid having superfluous gold covering the shop floor, like rose leaves in a garden in autumn. They use transfer gold if it is a draughty shop. It is usually a trifle dearer than plain, but try transferring your own. Insert tissue paper between each leaf carefully. Do as many books as you want for the job. Then squeeze the four or five books in a vise between two 5 or 6 in. pieces of flat wood. Leave it, if possible, over night. Every leaf will be fixed firm on the tissue. You can then cut it into strips for gold

bands and for lettering without waste. The old way of transferring is quite effectual. First cut up an empty gold book. Rub leaves with a hard stearine candle end. Interleave these with your new book, and all will transfer by gently passing the hand over the book outside. Gold leaf is  $3\frac{1}{4}$  in. square, 25 leaves in a book, four books in a hundred, and 40 books represent 1,000 leaves. If it is the best deep English it is 22 carat.

### Ideals in Lettering

In an earlier number of this journal the opinion was expressed that, in its higher branches, signwriting had done more for artistic lettering than any other branch of the lettering craft. At this stage it might be interesting to refer to some of the features which have marked the development of lettering as a whole.

The principal craftsmen making use of lettering are the mason, the engraver, the penman and illuminator, and the signwriter. There are two reasons why conditions have favored the higher development in letter formation in signwriting than in the other crafts. The mason works with a chisel and mallet, the engraver with a steel tool, and the manuscript writer with a pen. All of these tools are much more restricted in their capacity for expression than the pencil and brush of the signpainter. There is no more subtle instrument in the hands of a skilled craftsman than the sable pencil, and there is no freer or more expressive medium to work with than paint. The signwriter is offered an endless range. It is to his credit that he has made good use of his opportunities.

It may be safely said that the signwriter has done more than anybody else to stress the importance of spacing and layout of lettering.

He has been among modern letterers the pioneer in endeavoring to give all letters the appearance of equal width and weight.

The first good examples of letters were, of course, the old Roman inscriptions. These were adopted by penmen and old writers of manuscripts, and in the course of centuries, their outlines have undergone modification. The old forms, and especially the irregular width noticed in examples of old Roman letters, have been practically left behind. It was evidently considered that there was no justifiable grounds why such letters as P and B should not have the same width as other letters. Consequently the original Roman forms gradually disappeared. Centuries of use had shown that as the use of words was to convey the sense of writing, vagaries should be sacrificed for the sake of clearness. In a line of lettering, or a page of writing, no particular letters should stand out more prominently than others.

Though this principle of equality, or apparent equality of width was established long before the craft of signwriting gained anything approaching the importance it now enjoys, the principle seems to have been established as peculiarly appropriate to the craft. Of late years a movement was established outside the lettering crafts to revert

to the earliest types of Roman letters. Since the great Pre-Raphaelite movement, someone or other has, at various times, shown a disposition to upset established methods, and go back to historic times for models. Lettering is such an ancient art that it is possible to pick up good models at any period within a couple of thousand years. But the revival aimed at went as far back as to the period when the Roman Empire was at its zenith. The old Roman letter is certainly a beautiful example of lettering, but the variation in width was not essential to its beauty. It probably existed in the old form because the letter-artist had not shaken himself free of the idea of the supposed necessity of showing the mathematical basis upon which the Roman letter was originally based. It is hardly appropriate now for ordinary use, in these days when the letter-painter has come to trust to his eyes more than to the rule and compass. For some work it gives a refined, classic touch; but even here it would be pedantic and out of place to show it in its original crudeness. Few artists would attempt to do so.

Traditionally, the sign painter appears to have been less partial to the Roman letter than any other letter craftsman. The fact that his work had to be read sometimes close, sometimes at a distance, made it necessary for it to fulfil its mission under these varying conditions. In this the Roman letter was not the most successful. The "hair line" was a graceful and unobjectionable feature reviewed close, but from a distance it naturally disappeared.

Seriffs also were mainly ornamental. To obviate this defect, a letter was selected with all parts of more or less equal width, and without purely ornamental features. Hence the development of the plain letter called "block" or "Egyptian." While the letters used for printing developed upon the lines of the Roman, the signwriter, by reason of its obvious advantages for purposes of his work, appropriated the block or Egyptian style. In the hands of an expert it was capable of no end of use. By contracting or expanding it he could make it fit any space. By his skill in forming it he refined its outlines to such an extent that it could be used in the most decorative as well as the commonest circumstances, and still look pleasing and appropriate. The importance of this style letter is suggested by the saying common in the signwriting trade that a man should be judged by his ability to form plain letters. If he could do that well, he could safely be included in the ranks of expert craftsmen.

The essential difference between the Roman and the block styles of letters, as a matter of fact, express the essential differences between sign painting and most other forms of lettering. The sign painter differs from the engraver or type founder in exactly the same way that in art the painter differs from the draftsman, or the man who works only or mainly in black and white. The painter thinks in masses; the other thinks in lines.

A plain block letter is massed; the body of the letter forms one mass, and the background another. In many cases the area covered by the letters is equal to the area of the background. The truth of this fact is illustrated when one forms, in calico sign work, white letters on a blue ground by cutting in the background. No letter is more appropriate for this treatment than a plain style letter. In the case of the ordinary Roman letter, the practice would scarcely be possible.

In view of the recognition of the principle laid down

above, it may safely be predicted that this system of massing or maintaining a relative balance between background and letter will always be regarded as essential to the signwriting craft, and that the adoption of letters from any other source will require the modification of thin lines and of masses in accordance with the traditions of the trade.—Australian Coachbuilder and Wheelwright.

### Transparent Colors

These are mainly carmine and lakes. They are applied over a solid undercoat made of a color not so rich. The glaze covers fairly well over this. It is harder to glaze (or apply the transparent colors) to wheels and underparts of carriages and carts than to flat surfaces. The irregular surfaces, being round or presenting sharp edges, the brush applies the glazes unevenly—full in hollow surfaces, thin on prominent surfaces and edges; therefore applying transparent colors to bodies of motors (large flat surfaces) is easier than to wheels or under parts of old fashioned carriages. The glaze or transparent color is generally the same or as near the shade of the preparatory color over which it is applied. In a scumble one gets into another field—one in which great variety and variation of color is got by employing a glaze over a ground which may be of quite a different shade.

### Control of Hess-Bright and S. K. F. Merged

Control of the S. K. F. Ball Bearing Co. and the Hess-Bright Mfg. Co. now is centralized in the S. K. F. Administrative Co., just formed for the purpose.

On the directorate of the administrative company are the following: Frank A. Vanderlip, the well known banker; Thatcher Brown, F. B. Krikbride, S. Wingquist, Alexander Carlander, Marcus Wallenberg, the latter a Swedish banker, and B. G. Prytz, president of the S. K. F. company. Of these, Vanderlip, Brown, Kirkbride and Wallenberg are the ones who purchased control of the Hess-Bright company last November, buying the major part of the American holdings, and later the German stock interest as well. Plans are being perfected for increasing the plant facilities and outputs of both the Hess-Bright plant in Philadelphia, Pa., and the S K F factory in Hartford, Conn. No changes are to be made in the executive staffs of the two companies, save that B. D. Gray, the Hess-Bright president, becomes technical advisor for the Administrative company, thus placing his talents more completely at the disposal of the enterprise.

### Ervin Smith Bending Co.

The bending business of the late Ervin Smith at York, Pa., will be continued by the Ervin Smith Bending Co. The stockholders, Dr. L. H. Fackler, Mrs. E. Smith and George Stoll, were all associated with Mr. Smith. The company manufactures wheel rims for trucks, pleasure cars, carriages and wagons.

### Autos to Be Taxed by Weight in West Virginia

Beginning May 23, when the new vehicle law goes into effect in West Virginia, automobiles will be taxed according to weight. All automobiles weighing 2,000 pounds or less will be taxed \$10 and 25 cents additional will be charged for each additional 100 pounds.



### S. A. E. Summer Meeting at Washington

Definite plans concerning the summer meeting of the Society of Automotive Engineers, to be held June 25 and 26 at the Bureau of Standards, Washington, were settled at the May meeting of the Council of the society, which was held in the new S. A. E. offices in the Munsey Building.

An informal dinner will be held in the banquet hall of the New Willard Hotel, Tuesday evening, June 26. Secretary of War Newton Baker will address the engineers. The other speakers have not been decided upon as yet. The dinner will be \$6 per plate, and members are asked to make reservations through the New York office of the S. A. E. It is expected that this dinner will be the greatest get-together of the government officials and S. A. E. members in the history of the society.

The professional session on Tuesday, June 26, will be one of particular interest. Wing Commander I. W. Seddon, R. N. A. S., who is a member of the British Commission in this country, and who is demonstrating some of the British types of war airplanes here, has agreed to present a paper dealing with the practical aspects of airplane manufacture.

Major Rees, also of the British Commission, an experienced British aviator throughout the Somme campaign, has practically agreed to answer various questions on this interesting subject.

The matter of motor trucks in the European war is being handled by W. Owen Thomas, consulting engineer of Detroit. For over two years Mr. Thomas was head of military transport work for the Canadian government under Major-General Sam Hughes, former Minister of Militia for Canada. Mr. Thomas was on the French and British fronts for 14 months.

H. L. Horning, of the Waukesha Motor Co., is preparing a practical paper on farm tractors.

The motor-boat activities of the S. A. E. will be presented by Henry R. Sutphen, vice-president of The Elco Co., who will give an illustrated talk on standardization methods and production plans used in building the 500 submarine chasers, which this country supplied to the British government.

The professional session will be held at the Bureau of Standards, as will the Monday meeting of the Standards Committee. Arrangements have been made for serving luncheon each day on the lawn. The daily sessions are scheduled to begin at 10 o'clock and continue until 4:30.

It has been arranged to have an inspection of the various departments of the Bureau of Standards Monday afternoon, June 25, beginning at 3 o'clock.

The society is not undertaking to make any arrangements with regard to hotel reservations of members attending the meeting. Headquarters will be at the New Willard Hotel.

### 10,000,000 Corporation for Doble Steam Car

The Doble steam car which attracted so much attention at the automobile shows last winter is to be manufactured by the Doble-Detroit Steam Motors Co., which is to be incorporated under Michigan laws for \$10,000,000. Perfection of the organization is in the hands of a committee consisting of Claude L. Lewis, chairman, who is president of the General Engineering Co., first producer of the Doble; Abner Doble, the designer; Wade Millis, formerly

secretary of the Abbott Motor Co.; Morgan J. Hammers, secretary of the General Engineering Co.; T. P. Meyers, the General Engineering vice-president, and Frank M. Knapp.

The company will be financed through the sale of stock, which will be of \$10 par value, but will be sold at \$11 a share, the extra dollar paying the organization expenses, so that the full par value will reach the treasury in actual cash.

A luxurious seven-passenger car, priced in the neighborhood of \$2,500, will be produced first. Other models at lower prices will be added later. The company will also make use of steam in other directions, including commercial cars, tractors, motor boats, airplanes and even inter-urban cars. It will also offer Doble steam power plants to vehicle manufacturers wishing to use them.

### An Economy Tool

Garage owners, tool-room foremen and mechanics in general will be interested in knowing about such an adaptable little machine as the Rhodes Combined Shaper and Slotter, which is in use in many shops and tool rooms throughout the country. This handy little machine is wonderfully efficient and economical in shaping and slotting light work, and in making tools, dies, models, etc. It is really a "two-in-one" tool, and being fitted with attachments for vertical work is ready for both horizontal and vertical work at all times, covering a wide range of machining. Built like a big machine and sold for a moderate price, it is truly an economy tool, both in first cost and in operation. Full information and details descriptive of this machine may be had by writing the makers, The Rhodes Mfg. Co., Hartford, Conn.

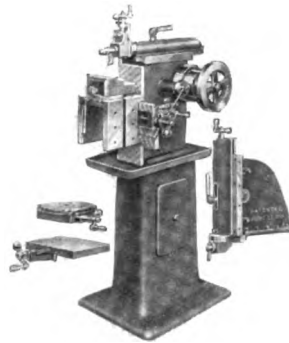

### Merging of Three Truck Firms

The Krebs Commercial Car Co., the Clyde Cars Co., Clyde, O., and the Lincoln Motor Truck Co., Detroit, have been merged into one company, the Clyde Cars Co., and will market five models of trucks to be known as Clydesdale.

C. R. Dunbar, of Holyoke, Mass., has been elected president of the new company; J. C. L. Krebs is vice-president and general manager; W. P. Dodge, formerly treasurer of the Barney & Berry Co., has been appointed assistant treasurer and sales manager; J. B. Crockett, president of the J. B. Crockett Co., New York, is treasurer, and Homer Metzger is secretary.

The Krebs company factory, with 80,000 ft. of space, will be utilized. All the tools and materials of the Lincoln company have been removed to Clyde.

### American Six Goes Up in Price

After May the American Six, made by the American Motors Corp., Plainfield, N. J., will sell at \$1,375. Consolidating its advertising department more closely with its organization, that department has been moved from New York City to offices at the factory.

### 40,000 Motor Vehicles for Army Use

That the government has no intention of commandeering any privately-owned cars is confirmed by the fact that Uncle Sam has appropriated \$100,000,000 for the purchase of motor equipment for the army and transport service.

The Army and Navy Journal, in discussing this question in its issue of May 12, says:

The information given the Ordnance Department and Quartermaster Corps by the French and British officers who arrived with their respective commissions will result in radical increases being made in the program for auto transportation for our new forces and in the schedules already announced for the increase of the regular establishment. It is learned that the reports made by such officers as Colonels Heron and Puckle, of the British Subsistence Department, emphasized the revolutionary effect that auto trucks have played in the forwarding of supplies from the primary bases and the eventual distribution along the front, just as reports from our military observers have stressed the tremendous use that is being made of mobile heavy artillery. Brigadier-General William Crozier, Chief of Ordnance, U. S. A., included in his estimates for the army bill which failed of passage in the Sixty-fourth Congress, some 58 armored automobiles, 230 machine gun motorcycles and 690 motorcycles for use in forwarding ammunition in emergencies. These figures have since been revised entirely, but we are not permitted to give the numbers that are now contemplated. The armored automobiles are to be along the same lines as those which comprise the unit included in the New York National Guard division. No serious attempt has been made by our ordnance experts to copy the "tanks" of which we have read so much, the reason for such hesitation being simply that confidential and trustworthy reports are that they have been spectacular failures.

As stated in a recent issue, the Q. M. C. estimates for the new army call for approximately 40,000 trucks and autos.

The various types and their cost are set forth as follows:

- 4,210 automobiles (touring) at \$1,000.
- 1,310 automobiles (runabouts) at \$850.
- 29,730 motor trucks (cargo) at \$2,800.
- 1,090 motor trucks (repair and kitchen) at \$3,200.
- 2,180 motor trucks (supply) at \$3,200.
- 220 wrecking and mess cars at \$1,500.
- 3,670 motorcycles at \$280.
- 20 mobile machine shops at \$25,000.

Despite the fact that \$100,000,000 is involved in the purchase of these machines, it must not be thought that our new forces will be best sustained on a self-propelled basis entirely. To the contrary, no less than 529,380 horses and mules are included in the transportation estimates. For cavalry, 252,950 horses were allotted at \$175 each; for light artillery, 9,280 at \$250. This last item is the one which will suffer the heaviest reduction under the new plan. In S. O. 98. War Department, April 28, 1917, a new special board was appointed to consider the extent to which these changes will be carried. It includes Major Lucian B. Moody, Ordnance Department; Major T. Moore, Field Artillery (General Staff); Captain W. A. Capron, Fifth Field Artillery, and George W. Dunham, of Washington. Captain Capron was included because of the experience of his command with motor-tractors at Fort Sill, Okla.

Subscribe for The Hub

### Quickwork Co. Succeeds Collier Smith

The Quickwork Co. has been organized to take over and operate the machinery business of H. Collier Smith, of Detroit. This business includes the manufacture of machinery for working plate and sheet metal for automobile parts. Mr. Smith retains the controlling interest and will have active charge of the operations of the company, which is capitalized at \$400,000. Officers include: H. Collier Smith, president and general manager; H. E. Groves, vice-president; A. F. Smith, secretary and treasurer; W. J. O'Leary, production manager; W. W. Prigg, director of sales, and Harry G. Smith, engineer.

### Buggy Traveler to Sell Autos

La Rue Stanley, of Little Rock, Ark., has resigned his position as traveling salesman for Delker Bros., Henderson, Ky., and on May 1 joined the sales force of the Mississippi Valley Motor Co., Oakland wholesale distributors at St. Louis. Mr. Stanley represented Delker Bros. in Arkansas and Louisiana, and for 20 years has sold buggies in the Mississippi Valley where he is well known to the vehicle trade. He will look after Oakland's interest in southern Illinois and will reside at Salem, Ill., which was his home some years ago.

### Franklin's Increased Production

The number of Franklin cars shipped from the factory at Syracuse during the six months ending May 1, 1917, shows an increase of 143 per cent over the previous six months.

In spite of this greatly increased production, the Franklin Company at present has on its books over two and a quarter times as many unfilled orders as at this time last year.

### Erskine Says Outlook Is Bright

A. R. Erskine, president of the Studebaker Corp., is very optimistic concerning the future of all kinds of business. He says: "This is no time for any man to feel pessimistic. The great resources of the United States, its energy and power are being employed in the war, and large expenditures must ensue, which in themselves mean prosperity for our people, in spite of the high prices and increased taxes that will prevail while the war continues."

### Parsons Mfg. Co. Triples Capacity

The Parsons Mfg. Co., Detroit, Mich., manufacturer of automobile body hardware, has again outgrown its plant and has leased a new factory at Stanley and Vermont avenues, where the present capacity will be tripled in order to meet the increasing demand for Parsons hardware. The new additional equipment will be installed and in operation by June 1.

### United Alloy Steel Now Operating Seventeen Furnaces

The United Alloy Steel Corp., Canton, O., now has 17 open hearth furnaces in operation. Nine of these were only opened recently, and a tenth new furnace went into operation on May 1. The company reports a record unfilled tonnage, and is taking no more orders for 1917 delivery.

## Toggle Automobile Rail Forming Press

A new double-action toggle press designed especially for forming rails for automobile frames and other forming work that requires accuracy and uniformity, and with which it is claimed very rapid production is possible, has been brought out by the Toledo Machine & Tool Co., Toledo. The first presses used for forming automobile rails were of the hydraulic type and later single-action crank presses were employed for this purpose. Both hydraulic and power presses are found in stamping plants engaged in turning out automobile frames in large quantities, the two types being generally used for forming different kinds of rails.

The first Toledo press of the double-action toggle type for rail forming was built for the Willys-Overland Co., Toledo, and was recently installed in that company's stamping plant. This machine has a capacity for exerting a pressure of about 2000 tons. It will form pieces 17 ft. long of chrome nickel or other high grade steels  $\frac{3}{8}$  in. in thickness. An idea of the size of this machine will be gained from the dimensions. It is 15 ft. front to back, 20 ft. 8 in. right to left, and 31 ft. from the base to the

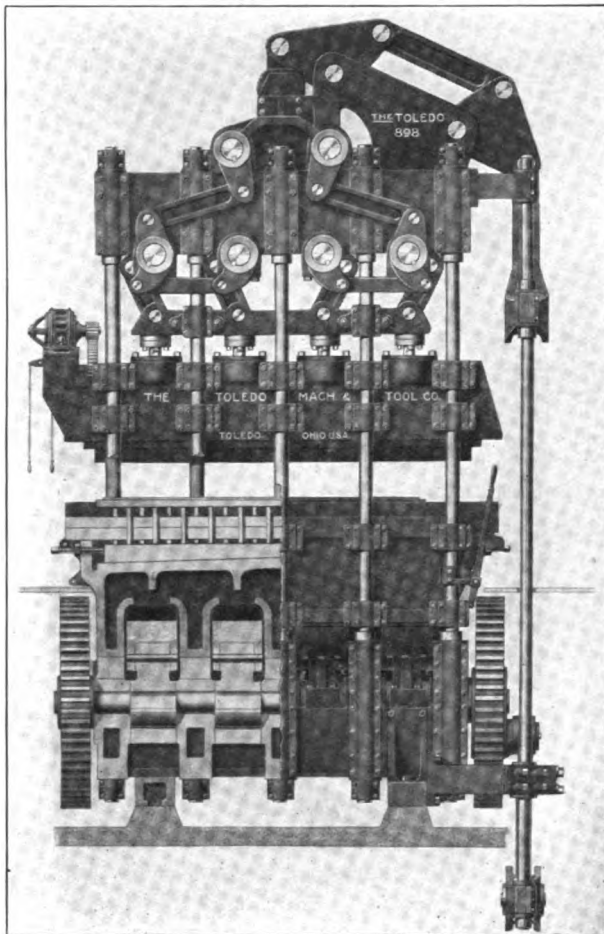

Double-action toggle press for forming rails for automobile frames, which is located in a pit extending 8 ft. below the floor

extreme top. It extends in a pit 8 ft. below the floor line. The complete weight of the machine is 650,000 lbs., or 325 tons. It is operated by a 125 h.p. motor. It is practically all of steel construction and some of the single parts weigh approximately 40,000 lbs. each. Six flat cars of a large capacity were required for its shipment.

In the production of rails for automobile frames, it is

considered essential that the vertical web be free from warping or buckling. In this press the blank is held firmly between the top of the die and the blank holder during the process of forming, so that, it is stated, warping or buckling is impossible, and all subsequent hand straightening is avoided, thus eliminating the expense entailed by this method of straightening.

The machine is self-contained and employs only two motions in the process of production. One slide comes

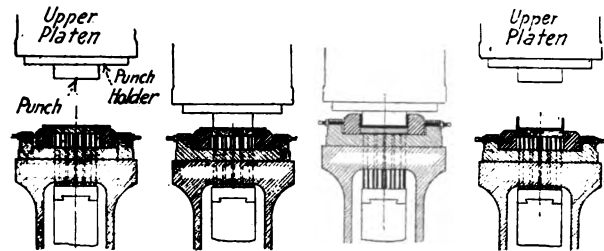

The successive positions assumed by the die and the punch in a complete cycle of the press

down and clamps the flat blank or sheet without any belt exertion, holding the blank flat while the second movement of the machine forms the sides of the channel or frame, and continuing on to the completion of one orbit when the finished channel rests free of all die obstruction on top of the die. The formed part is then ready to be swept off without the necessity of prying off or stripping. The channel, frame, or other part formed on the machine is said to be free from buckle in the web and from twist in its sides. It is claimed that over 90 per cent of the actual labor required in producing forms of this type is saved because of the elimination of hand processes of straightening.

The press operates at about seven strokes per minute, producing two complete rails of normal size and shape, one right and one left rail at each stroke. It is stated that one operator and two to four helpers, depending on the size and shape of the rails, are sufficient to operate the machine.

The frame of the press is massive in construction, and is securely held together by large steel tierods that take the stress. The crown, bed, blank holders, yokes, links and smaller castings are all steel to give the maximum strength to withstand the enormous pressure required for the work, the machine being designed to provide ample power and strength. The shafts are of the eccentric type, are hammer forged of special analysis steel, high in carbon, and are of large diameters. The press is fitted with a Toledo friction clutch operated by a hand lever, which gives the operator control of the machine at all times and enables him to stop or start instantly at any point of the stroke.—The Iron Age.

## Wisconsin Forbids Altering Numbers

By making it a crime to alter or obliterate the manufacturer's serial number on an automobile, the Wisconsin legislature hopes to reduce materially the number of cars that disappear each year through the operations of thieves. In addition to a penalty for the actual act, all persons who buy or sell or conceal an automobile so mutilated are made equally liable. That a person has bought, or sold, or otherwise had anything to do with a machine in such condition is presumed to be evidence of his knowledge of its illegal condition.

### **Additional Government Truck Specifications**

J. A. Edgerton, purchasing agent of the postoffice department, has given notice that in addition to other specifications trucks to be purchased for post office service in the future shall include this equipment:

Two electric or gas headlights equipped with dimmers, two oil side and one oil tail light, one mechanical or electric horn, one hub odometer of type approved by the department to be attached to left front wheel, one jack, one set of anti-skid chains of approved design and appropriate for size of truck, one standard set of tools. Side oil lamps to be one-piece heavy steel body, double supports, combination socket, round body. Tail oil lamp to be one-piece heavy steel body, left hand single support, combination socket, round body.

The department is also contemplating the extension of motor service in the near future to all star routes it controls, motor service now being very generally in use in the rural free delivery service.

### **Swiss Adopt 3 1/2-ton Army Trucks**

Swiss automobile manufacturers have decided on the adoption of the 3½-ton truck as the most suitable type for military service in that country. The decision was arrived at after a meeting of the manufacturers and the military authorities. A suggestion was put forward for the creation of a uniform type of truck, to be made by all firms, sold to private users, and which could be requisitioned by the army in case of necessity.

It is practically certain that the Swiss authorities will adopt the French system of truck subsidies. Under this arrangement the military authorities agree to subsidize for the first three years of their existence any privately owned truck of an approved army type. The owner must present his truck annually for examination and must deliver it to the authorities in case of war. This subsidy only covers 2½ and 3½-ton trucks. In selecting the approved types the authorities are more concerned with performance than with design.

### **Philippine Imports Gain 50 Per Cent**

The Bureau of Insular Affairs of the War Department, which has jurisdiction over customs matters for the island dependencies of the United States, in a statement on the import trade for 1916 of the Philippine Islands states that, despite a depression generally due to the war, the automobile trade showed marked development. Continuing, the report says:

"There was a 50 per cent increase in the number imported, and though the war was characterized by the usual condition of declining average price, due to cheapening production and the increase in lower grade machines, the aggregate value of automobiles was materially larger than that of 1915, and there was also a marked increase in parts and equipment.

"Manila as an oriental distributing point for the American automobile trade is indicated in exports of some importance of American machines to nearby countries."

### **Receiver for Ben Hur**

The Ben Hur Motor Car Co., capital \$1,000,000, with factories and offices at Willoughby, O., is in the hands of a receiver, Charles P. Moore, of Cleveland. Inability of the company to obtain materials is said to be the cause.

### **Dealer Sells Many Buggies**

R. W. Lemmon, the well known vehicle dealer of Falmouth, Ky., since January 1 has sold 51 buggies and 36 sets of harness. Saturday was the banner day in his sales repository, when he sold nine up-to-the-minute buggies, one of them going to a party at Dry Ridge. Mr. Lemmon is the most extensive vehicle dealer in this section of Kentucky, and it will be seen from the large sales this season that this way of travel is not going out of style by any means. Mr. Lemmon received two more carloads of buggies May 1.

### **Wagons for War Use**

The government's plans call for 50,000 new army wagons, orders for which will be placed with a number of manufacturers. Production of these wagons will require longer time than would be needed for the same number of ordinary farm wagons. Probably these orders, so far as the time required is concerned, will be equivalent to three times as many farm wagons. On this basis capacity for 150,000 farm wagons will be diverted.

### **Outing of Carriage Makers' Club**

The board of governors of the Carriage Makers' Club, of Cincinnati, at a special meeting, decided that the June outing will be held at Laughery Island, Saturday, June 9. While the chief feature will be the boat ride to and from the island, the club never does anything by halves and it is safe to say that there won't be an idle moment from the time the boat starts until it arrives home.

### **Harry McCullough Promoted**

The promotion of Harry J. McCullough, head of the wagon division of the Emerson-Brantingham company, Rockford, Ill., to take charge of the vehicle and wagon sales division is announced. Mr. McCullough was secretary of the Newton Wagon Co. at the time of the merger with the E-B company and had previously had experience in the carriage business in Cincinnati.

### **Columbus, O., to Have Speedway**

A number of well known citizens of Columbus, O., have formed the Columbus Motor Speedway and Horse Racing Co., which will be incorporated for \$200,000. A site has already been selected, a two-mile automobile speedway will be built and also a horse racing course. The president and general manager of the company is John Y. Bassell.

### **Plan Aeroplane Output**

It is reported that Sidney D. Waldon, former chief engineer of the Packard Motor Co., and William H. Hutton, former purchasing agent of the Timken-Detroit Axle Co., have arranged with competent builders for the government to obtain aeroplanes at the rate of 640 in 1917, 2,400 in 1918, and 5,500 in 1919.

### **Timber Resources**

The estimated total supply of merchantable timber in the United States is 2,500,000,000 board feet, that of Canada is 500,000,000 feet. Russia is believed to have the largest timber resources of any country in the world; the United States is second and Canada third on the list.

# Vehicle Industry News in Brief

## Truck Builders

F. D. Truck & Auto Co., Adrian, Mich., has been formed as a successor of the Forduplex Co.

Duplex Truck Co. will erect a factory at Lansing, Mich., 72 x 608 ft., two stories high with a basement.

Hurlbut Motor Truck Co., Third avenue and Harlem River, New York, has increased its equipment to handle about 40 trucks on its floor.

Packard, Detroit, has placed an order for 3,000 truck radiators to be delivered by June 30. The company usually buys 200 radiators per month.

Federal Motor Truck Co., Detroit, has received orders for four 3½-ton trucks for the American Red Cross and four 3½-ton trucks for Red Cross service in Belgium.

Famous Trucks Mfg. Co., St. Joseph, Mich., has taken over the plant and business of the Deitch-Denton Co., and will begin operations as soon as its men can be brought from Chicago.

International Motor Co., Allentown, Pa., has received an order from the British government for 150 Mack motor trucks of 7½-ton capacity. The order will amount to more than \$700,000.

Republic Motor Truck Co., Alma, Mich., is reported to be planning the erection of an assembling plant near Los Angeles, Cal. Negotiations are under way for a site of three or four acres.

Republic Motor Truck Co., Alma, Mich., is making extensions and improvements to build 50,000 motor trucks in 1918. The company built 7,000 trucks in 1916 and will turn out 23,000 this year.

Smith Form-a-Truck Co., Chicago, has let contracts for the erection of a one and two-story factory addition, 160 x 260 ft., at Sixty-sixth street and Fifty-eighth avenue, at an estimated cost of \$90,000.

J. C. Wilson Co., Detroit, has completely remodeled the executive offices and the assembly floors of its motor truck plant. The expansion was necessitated by the addition of 1 and 3½-ton models.

Tower Motor Truck Co., recently organized, has just started operations in its new plant in Greenville, Mich., and expects to be turning out 100 machines this year. The building is fireproof, 60 x 220 ft.

Oberlin Auto Truck Mfg. Co. has purchased the building formerly occupied by the Kyle Mfg. Co., at Lancaster, O. The new concern will be capitalized at \$1,200,000. About 250 men will be employed.

Rainier Motor Corp., New York, has sold a fleet of 25 trucks to the United States government. These trucks are to be used by the Navy Department. All of the trucks are of the ½-ton capacity with express bodies.

Acason Motor Truck Co., Detroit, will build an addition to its plant, doubling or trebling the present floor space.

R. G. Shuert, formerly connected with the Indiana Truck Co., took over the management of the factory March 1.

Bessemer Motor Truck Co., Dover, Del., has been incorporated with a capital of \$2,000,000, to manufacture automobile trucks of different kinds. C. L. Rimlinger, Clement M. Enger and M. V. Haywood, Wilmington, are local incorporators.

United Motortruck Co., Grand Rapids, Mich., is having plans drawn for an addition to its plant, 75 x 300 ft., which will be used for the manufacture of a tractor and trailer. The company now employs 150 men and it is expected that this force will be doubled.

Maxfer Truck & Tractor Co. has outgrown its present quarters in Chicago and is moving to Harvey, Ill. It will occupy the former plant of the Packless Valve Co., which will double the capacity of its present plant, and in addition will have better railroad facilities.

Collier Motor Truck Co., Sandusky, O., plans the erection of a large plant for the manufacture of motor trucks following its announcement that it has received an order for building \$2,000,000 worth of trucks. The company plans a brick and steel building, 70 x 400 ft., to be used for assembling purposes.

Lumb Motor Truck & Tractor Co., newly formed at Aurora, Ill., exhibited its first truck to stockholders and the local public recently. It is a two-ton model, weighing only 5,400 pounds, powered with a 37 horsepower Buda engine, and equipped with Bosch ignition and lighting system. The oiling system is said to require little supervision.

The Belmont Motor Corporation, recently incorporated in Delaware, has acquired the former North American Tannery building at Lewiston, Pa., and plans the establishment of a new motor truck plant, to specialize in initial operations in assembling work. C. G. Gochanaur, Harrisburg, is one of the promoters.

Wisconsin Duplex Auto Co., Clintonville, Wis., has been organized with a capital of \$500,000, to manufacture motor vehicles. More than one-half of the capital has been subscribed and arrangements will be made at once for the establishment of a plant, which will be equipped to manufacture a one-ton commercial car and later a pleasure car.

American Motor Truck Co., Detroit, has purchased a factory plant which it is converting for truck manufacture and has commenced the installation of machinery and material. The new factory is a one-story brick structure with 40,000 sq. ft. of floor space. The truck is manufactured in 2, 3½ and 5-ton models, all of which sell for more than \$3,000 each.

## Body Builders

Porter Body Co., Ypsilanti, Mich., is contemplating enlargements to its plants as the result of a large order for its product.

Hale & Kilburn Co., Philadelphia, maker of automobile bodies and railroad equipment, is erecting an eight-story factory building at Sixth and Filbert streets, costing approximately \$500,000.

Meteor Motor Car Co., Piqua, O., has acquired the plant of the Klanke Furniture Co., and will fit it up for the manufacture of wooden and steel bodies for motor-driven ambulances and hearses.

Barnett Auto Body Co. is a new automobile body building plant added to the list of industries in Portland, Ore. Until its projected factory is ready the company will have quarters in the Pacific Storage Co.'s building at East Madison and First street.

Saginaw (Mich.) Auto Body Co. has been incorporated with a capital of \$100,000, to manufacture automobile bodies. The company has purchased a plant and will start production in the near future.

Rex Mfg. Co., Connersville, Ind., maker of sedan tops, will erect an addition to its plant. The building, which will be of brick and concrete, will be three stories high with full basement, 100 x 60 ft.

Stockbridge Body Co., Springfield, Mass., has been incorporated with authorized capital stock of \$20,000. The directors are James P. Smith, president; Raymond S. Smith, treasurer, and L. McC. Smith.

Field Mfg. Co., which recently moved to Owosso, Mich., from Ionia, has begun shipping truck bodies. The company manufactures a ½-ton truck body in the plant of Republic Motor Truck Co., Alma, Mich.

Auto Body Works, Appleton, Wis., established several months ago to build all kinds of bodies for passenger and commercial motor vehicles, has incorporated its business under the style of Auto Body Works Co., with a capital stock of \$5,000. The owners are Dudley Pierce, Gustave C. Seeger and Humphrey Pierce.

Biggam Trailer Co., manufacturers of trailers and commercial bodies, will move from Detroit to Corunna, Mich., between Flint and Lansing, where two factories on a ten-acre tract will be occupied. In plant A, trailers and bodies for heavy commercial work are manufactured, while plant B is devoted to automobile trailers and light commercial bodies.

Springfield Body Corp.'s new plant at Detroit has individual motor power for each wood and metal working machine, and is equipped to produce a Springfield body every 20 minutes. The building has nearly 6,500 windows, and numerous skylights. A special spur from the Michigan Central Railroad, four-fifths of a mile long, provides ample shipping facilities.

Springfield Body Corp. has established a service station at 123 W. 64th street, New York City, following the plans of the tire, battery and carbureter makers. Owners of cars may take them there, or to similar stations in other cities, and receive intelligent advice on repairs, repainting or upholstery from experts, who will have at hand every aid to do the work right.

C. R. Wilson Body Co. has secured \$1,000,000 in three and five-year 6 per cent bonds for its plant in Bay City, Mich., which it uses for wood working. The company is negotiating with one automobile manufacturer for a contract for 30,000 automobile bodies. When this contract is closed the company will probably greatly increase its building and machinery capacity.

Central Mfg. Co., Connersville, Ind., body manufacturer, whose plant was destroyed by fire in April, has let contracts for a new building. In the meantime the company is manufacturing bodies at the plant of the Rex Mfg. Co. and at the Connersville Industrial Building. W. B. Ansted, president, says a new plant will be erected as soon as possible. The new structure will be considerably larger than the plant which was destroyed with a loss of \$150,000. The main building, for which a contract has been awarded, will be 800 x 125, and will be used for the manufacture of metal parts. Another building, 100 x 50 ft., will also be erected. The company hopes to occupy its new plant by July 1.

Hayes-Ionia Co., Grand Rapids, Mich., is offering \$175,000 worth of 7 per cent cumulative sinking fund preferred stock to the public. The company, incorporated in 1911, manufactures automobile bodies and sheet metal parts. The principal customers are: The Willys-Overland Co., the Reo Motor Car Co. and the Olds Motor Works. The company has recently leased a new plant in Grand Rapids and has signed contracts utilizing its entire capacity, which makes an approximate increase of \$2,250,000 in gross business. The company claims its net assets are three times the total preferred stock issued, and that net earnings are four and one-half times the dividend requirements on preferred stock. Gross business of the company increased almost 400 per cent in the last five years.

### Parts Makers

Springer Wire Wheel Co. is about to start manufacturing in its new plant at Detroit.

Pantasote Leather Co., Jefferson street, Passaic, N. J., has increased its capital from \$250,000 to \$500,000.

Timken Roller Bearing Co., Canton, O., has established a department which will furnish bearings for application to farm tractors.

Wisconsin Motor Mfg. Co., Milwaukee, has awarded the general contract for a one-story reinforced concrete and steel shop addition, 112 x 226 ft.

Hayes Wheel Co., Jackson, Mich., has let contract for the erection of a one-story factory, 50 x 235 ft., as an addition to its hub plant in Albion, Mich.

D'Arcy Spring Co., Kalamazoo, Mich., will enlarge its factory at an estimated expenditure of \$100,000. The factory force will also be greatly increased.

Erie (Pa.) Foundry Co. has just taken an order from the Studebaker Corporation for 18 steam drop hammers ranging from 3,000 to 5,000 lbs. capacity each.

G. Mitchell & Son Co. will erect a plant in Cleveland for the manufacture of sheet metal parts for automobiles. When fully equipped the plant will cost \$250,000.

Fedders Mfg. Co., Buffalo, N. Y., manufacturer of automobile radiators, is building a two-story brick and steel addition to its plant at Tonawanda street and West avenue.

A plant for the manufacture of automobile fenders will be established in Ashtabula, O., by the Save-a-Life Fender Co., which will occupy the building formerly used by the Ashtabula Woolen Mills.

Peters & Harron Dash Co., Columbus, O., which manu-



factures Invincible seat covers, tire covers, etc., is building a one-story factory addition, 65 x 100 ft., which will double the size of its plant.

The Napoleon (O.) Crown Fender Co., capital \$20,000, has been sold to C. D. Peifer, of Fostoria, O. It will remain at Napoleon and the entire output will be taken by the Allen Car Co., Fostoria.

Stewart Wire Wheel Corporation, Dover, Del., has been incorporated with a capital of \$500,000, to manufacture wire wheels for automobiles. J. B. Bailey and Arthur J. Kingsbury, Dover, are the incorporators.

Canton (O.) Rim Co. has been incorporated with a capital stock of \$100,000, and will establish a plant to manufacture automobile rims and automobile specialties. A. R. Turnbull and others are interested.

One-Hand Top Co., Buffalo, has leased 30,000 sq. ft. of floor space in the Chase & Baker Building, East Jewett avenue and the New York Central Railroad Belt Line, and will equip it for the manufacture of automobile tops.

Peerless Wheel Co. of California, Los Angeles, has been incorporated with a capital of \$15,000, to manufacture automobile wheels. Fred E. Powers, George E. Somarindyk, and R. A. Armstrong, all of Los Angeles, are the incorporators.

Clark Equipment Co., Buchanan, Mich., will build a new machine shop, 180 ft. long by 60 wide. This, with improvements in the company's steel foundry, where the special steel that goes into its wheels and Celfor five-ton axles is produced, will make possible a daily output of 100 wheels.

Manufacturing is expected to commence within the next 30 days in the new plant of the Spranger Wire Wheel Co. at Detroit, which in January last increased its capital from \$100,000 to \$300,000 to provide increased facilities. By June 15 the plant will be in full operation. It is located at Parkinson and Clayton avenues.

Toledo Machine & Tool Co., Toledo, O., has acquired a 96-acre site at Dorr street and the New York Central Railroad, on which it will erect a new plant, the first unit of which will be built as soon as plans are prepared. The new plant will be used for the building of heavy presses and the present plant confined to the manufacture of the smaller type of presses. The erection of a foundry on the new site for the manufacture of castings used in its own plant is also being considered.

### Car Builders

Crow Motor Co. will erect a plant at London, Ont., to cost \$100,000.

Harroun Motors Corp., Detroit, has started production and is now building motors.

Eastern Motors, Inc., Hartford, Conn., is testing its first new car. Deliveries in quantity are to start in August.

Revere Motor Car Co., Logansport, Ind., has begun the erection of a manufacturing building to cost \$50,000.

Studebaker Corp., South Bend, Ind., will build a machine shop, to cost \$200,000, at Kendall and Sample streets.

Comet Automobile Co. is erecting a plant at Decatur, Ill., to cost \$75,000. The company moved from Rockford, Ill.

North American Motors Co. will soon start on the construction of its new plant at Pottstown, Pa. The building will be 302 x 72 ft.

Plant of the Enger Motor Car Co., Cincinnati, will be sold at public auction May 24 and 25 by Winternitz & Co., Chicago, for the receiver, L. J. Dauner.

Plant of the Alter Motor Car Co., Plymouth, Mich., is offered to the public for sale. It contains 22,000 ft. of floor space and is equipped for the assembling of automobiles.

Thibert Mfg. Co., Worcester, Mass., has been incorporated with a capital of \$50,000, to manufacture automobiles. Napoleon R. Thibert, Worcester, is president and treasurer.

Chalmers Motor Co. has purchased six acres of factory land from the city of Windsor, Ont., and will begin the erection of a two-story factory. This building will replace the one recently destroyed by fire.

The Olympian Motors Co., Pontiac, Mich., will construct a new assembling building, one story, 300 x 800 ft. Work will begin as soon as the labor and material situation becomes favorable. R. A. Palmer is president.

Stanley Motor Carriage Co., Wilmington, Del., has been incorporated with a capital stock of \$13,100,000, to manufacture automobiles. E. Latter, C. L. Rimlinger and C. M. Egner, Wilmington, are the local incorporators.

Ford Motor Co. of Canada will erect an addition to its plant at London, Ont., to cost \$150,000. The head office of the company is at Ford City, Ont. It plans to install a complete plant for enameling automobile bodies, including large ovens.

Grant Motor Corp., Cleveland, has purchased additional land adjoining its present new plant and will build several buildings at a cost of \$500,000. One building will be 647 x 160 ft. and another 400 x 160 ft. In addition, there will be a new office building 40 x 160 ft.

The plant of the S. S. E. Co., Philadelphia, is completed and will soon be in readiness to make \$5,000 chassis. Victor Lee Emerson, president of the company, states that although nothing will be turned out for several months, the plant is sold ahead for one year.

Manufacturer of Kerston-Gas-Electric car will begin in Detroit shortly. Harry Kerston, formerly designing engineer of the Studebaker Corp., is now associated with J. William Barnes in the formation of the new company which has opened offices at 910 Kresge Building, Detroit.

Work was started at Logansport, Ind., on the construction of the buildings for the Revere Motor Car Co., which will assemble the Revere car, using a Duesenberg engine. The buildings will have a floor space of 33,000 sq. ft., and the plant will have a capacity of 2,500 cars yearly. The buildings will be finished in 60 days.

### Miscellaneous

George Delker Co., Henderson, Ky., manufacturer of buggies, etc., has increased its capital from \$100,000 to \$150,000.

Heinzelmann Bros. Carriage Co., Belleville, Ill., has increased its capital stock of \$35,000 to \$75,000 and will add new equipment.

Jahn Semi-Trailer Co., Detroit, has been incorporated with a capital stock of \$5,000. Lillian K. Jahn, Arthur J. Kring and William M. Jahn are the stockholders.

Eagle Wagon Works, 4468 Richmond street, Philadelphia, manufacturer of wagons and wagon parts, will build a two-story plant, 55 x 80 ft., at Lefevre and Salmon streets, to cost about \$12,000.

West End Wagon Works, Newark, N. J., has been organized to operate a wagon manufacturing and repair plant at 586 South Twelfth street. Jacob Feldman, 455 South Thirteenth street, is president.

Empire Auto Trailer Co. has been organized at Buffalo, N. Y., with a capital stock of \$50,000, to manufacture motors, vehicles, machines and accessories. The incorporators are C. B. Howell, Frederick Tucker and Jos. Kazubowski.

Jerry O'Mahony, Inc., Bayonne, N. J., operating a plant for the manufacture of wagons at 49 Lexington avenue, has incorporated for \$1000,000 to specialize in lunch wagons and parts. The company has filed plans for the erection of a one-story plant at 70-78 Boulevard, to cost about \$7,000.

Warner Mfg. Co., Beloit, Wis., has been incorporated with a capital of \$50,000, to manufacture automobile trailers and similar vehicles. The incorporators are A. P. Warner, L. A. Avery, M. O. Mouat and L. J. Westlake. The company has been operating a plant for some time but intends to enlarge its facilities.

Highway Trailer Co., Beloit, Wis., organized with \$185,000 capital stock by James W. Menhall, to manufacture trailer attachments, has leased the plant and equipment of the Edgerton Wagon Works Co., Edgerton, Wis., and took possession May 1. Mr. Menhall recently sold his interest and relinquished the vice-presidency of the Warner Auto-Trailer Co., Beloit, to organize the new company.

State forests, with a total of over 3,600,000 acres, have been established in 13 states. Of these New York has the largest forests, which comprise 1,826,000 acres; Pennsylvania is second with 1,008,000 acres, and Wisconsin third with 400,000 acres.

## WANTS

Help and situation wanted advertisements, 1 cent a word; all other advertisements in this department, 5 cents a word; initials and figures count as words. Minimum price, 30 cents for each advertisement.

**Wanted**—Copies of The Hub of May and July, 1916. Must be in good condition. Address Trade News Publishing Co., corner Elm and Duane streets, N. Y. City.

### PATENTS

**Patents**—H. W. T. Jenner, patent attorney and mechanical expert, 606 F St., Washington, D. C. Established 1883. I make a free examination and report if a patent can be had and exactly what it will cost. Send for circular.

### FOR SALE

**For Sale**—"Motor Body Work for Commercial Cars," a new text book dealing with the construction of all types of bodies for business purposes. Contains also six working drawings and a glossary of technical terms, together with diagrams and sketches. Price, \$1.20 net; by post, \$1.56. Orders should be accompanied by remittance. Cooper's Vehicle Journal, Ltd., 19 Garrick street, Long Acre, London, England.

WE ARE PREPARED  
TO RENDER  
RAPID SERVICE  
ON  
STEEL SASH FRAMES  
MOULDINGS  
TUBING  
AND  
SPECIAL SHAPES  
MADE TO YOUR BLUEPRINT

The  
**Empire Art Metal Co.**  
Inc.  
COLLEGE POINT, N. Y.

# Production! How's This?

**1,100 Pinions Per Day  
Every Working Day for Three Years**

These are steering gear pinion blanks, manufactured for the Ford Company by the Gemmer Manufacturing Company, Detroit, Michigan. The length of the ground portion is 1 1/2 in.; the diameter 7/16 in. Accuracy is held within 0.001 in. One Norton Grinding Machine finishes 1,100 of these parts per day—every day—and has been operated on this work exclusively for a little over three years.

This machine is one of six "Nortons" owned by the Gemmer Company—all doing equally good work. We are proud of this installation because each machine was pur-

chased to do one particular thing. The requirements in this shop are severe—not extraordinary, perhaps—but held to rigidly, both as to quantity and quality of work.

How about applying Norton methods to your work? Let's discuss the matter. Tell us what you grind or what you think you might grind and we'll give you the benefit of our experience.

*Booklets and  
specifications upon  
request*

**NORTON  
GRINDING CO.**  
NEW BOND ST., WORCESTER, MASS.  
Chicago Store, 11 North Jefferson St.

AGENTS—Vonnegut Machinery Co., Indianapolis; Robinson, Carey & Sands Co., St. Paul and Duluth; Manning, Maxwell & Moore, Inc., St. Louis; The Motch & Merryweather Machinery Co., Cleveland, Pittsburgh, Cincinnati and Detroit; Eccles & Smith Co., San Francisco, Portland (Oregon) and Los Angeles; Henry Prentiss & Co., Inc., New York, Boston, Rochester, Buffalo, Syracuse, Scranton; Canadian Fairbanks, Morse Co., Montreal, Toronto, Winnipeg, Vancouver; Alfred Herbert, Ltd., Coventry (England), Paris and Milan; F. W. Horne Co., Tokio, Japan; The W. E. Shipley Machinery Company, Philadelphia; Kemp Machinery Co., Baltimore; C. T. Patterson Company, New Orleans; Post Van der Burg & Co., Rotterdam; Iznosskoff & Co., Petrograd, Moscow and Ekaterinbourg, Russia.

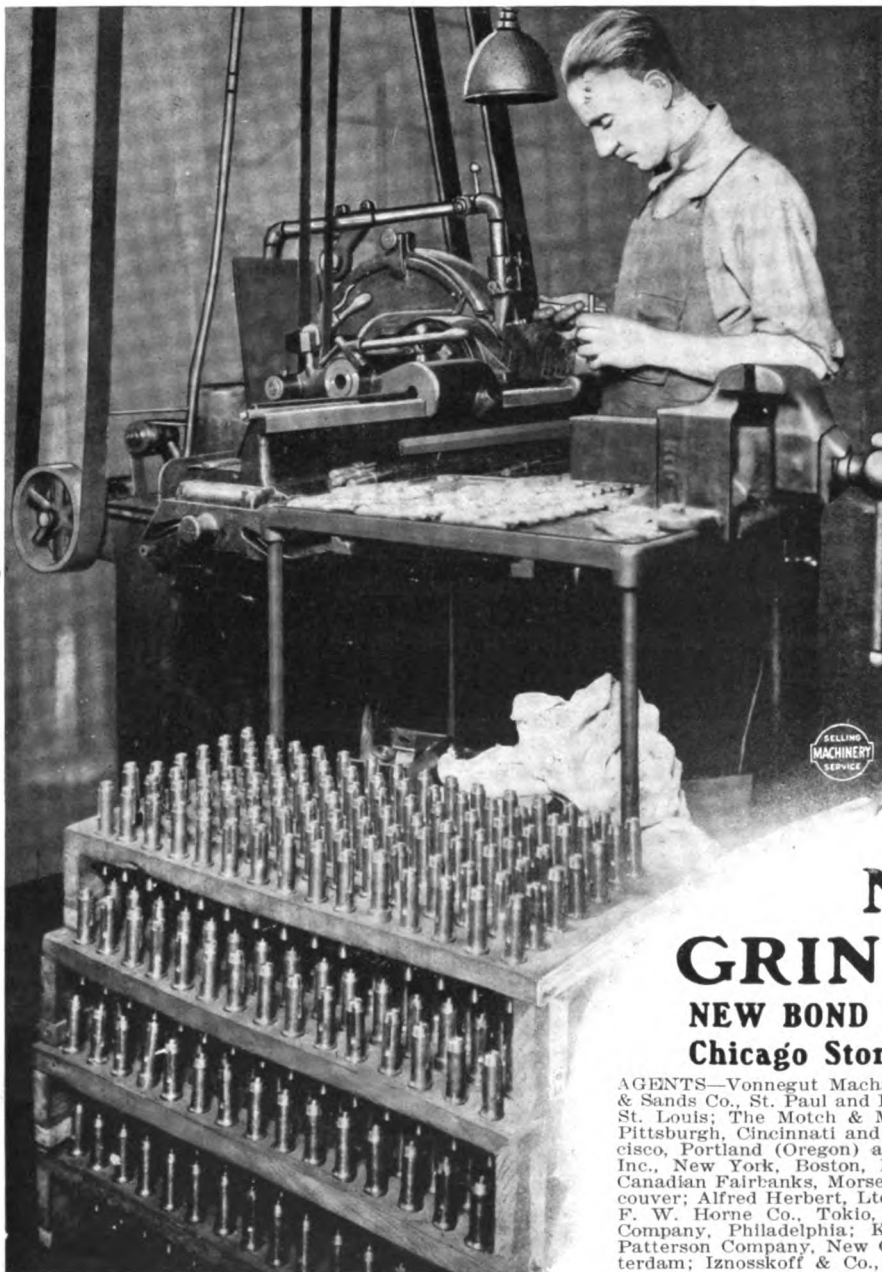

# MERITAS

## LEATHER CLOTH

### The Leading Leather Substitute Used by the Leading Manufacturers

This company is the largest manufacturer of this class of goods in the world.

To have attained this position we must have given the trade quality goods—material that gives the ultimate carriage and automobile buyer the utmost satisfaction.

Manufacturing on an enormous scale—operating five great factories, we are in a position to buy over usual high grade raw materials and guarantee the quality of Meritas Leather Cloth up to our regular quality.

We make a very extensive line of Meritas Leather Cloth in all weights, finishes, colors and grains.

Simply write us for what purpose you require a leather substitute and we'll submit samples.

Genuine Meritas Leather Cloth always has the trademark stamped on the back of the goods.

**The Standard Oil Cloth Company**

INCORPORATED

320 Broadway

New York



# The United States Government

## War Department

when calling for proposals and bids for machinery  
recently specified machines made by the  
**PETTINGELL MACHINE CO., AMESBURY, MASS.**

In an emergency the United States Government  
Engineers want the best—machines that can be  
depended on to do the work at all times, so they

## SPECIFIED THE PETTINGELL MACHINE CO.'S MACHINES

**THIS FACT SPEAKS VOLUMES**  
When you want the best order **PETTINGELL** Machines

**Bevel and Mitre Saw Tables**                      **Improved Saw Tenoners**  
**Irregular Shapers**

**Automatic Power Hammers**                      **Friction Drive Rotary Metal Cutters**  
**Beading and Moulding Formers**                      **Rolling Machines**  
**Foot Presses**    **Cornice Brakes, Etc.**

MANUFACTURED BY

# **THE PETTINGELL MACHINE CO.**

**AMESBURY, MASSACHUSETTS**



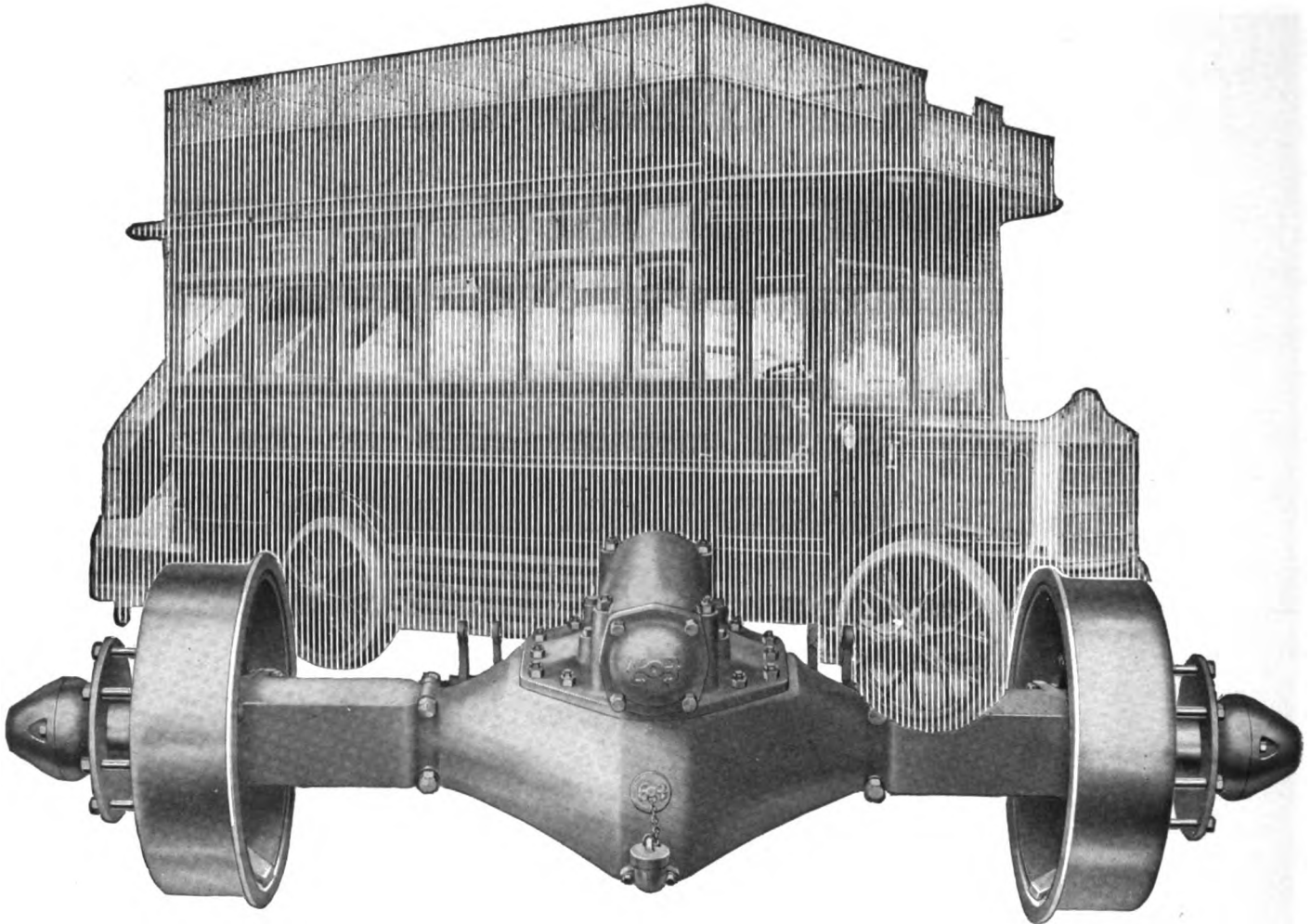

**If Cost Had Been the Only Consideration  
The Fifth Avenue Coach Company  
Never Would Have Adopted**

# SHELDON

## Worm Drive Rear Axles

**THE FIFTH AVENUE COACH COMPANY** of New York could buy any other type of drive and any other make of worm gear axle cheaper than SHELDON.

**BUT OPERATING THE FIFTH AVENUE BUS LINES** is very much of a dividend paying business proposition. Mere quality claims are discounted. Performance alone counts in the selection of the units which go to make up the famous Fifth Avenue Buses.

**FOR YEARS PAST** the Fifth Avenue Coach Company have been trying out in

actual service virtually all different makes of axles with a view of ultimately selecting for standard equipment the axle which showed the lowest-cost-per-mile haulage.

**SO, EACH DAY** accurate cost records were tabulated. Fuel consumption, oil consumption, tire mileage, maintenance costs and replacement charges were accurately figured each day. The sum total of these records now gives indisputable evidence of the superiority and lower-service-cost of SHELDON axles and in the future all Fifth Avenue Buses will be SHELDON equipped.

**THIS EXHAUSTIVE ELIMINATION** test should prove of invaluable aid to every prospective truck buyer in helping him in his final selection of a truck, for it places at his disposal the results of accurate cost records which would take him years to personally compile.

**ANY TRUCK DEPENDS** for its final efficiency on its rear axle. Be guided by the experiences of a firm who really knows. Write for a copy of the report made by The Fifth Avenue Coach Company of what they learned after their two-year elimination test.



**SHELDON AXLE and SPRING COMPANY**

*Makers of Springs and Axles for Heavy Duty Service for over Fifty Years*

Wilkes-Barre

- - - - -

Penna.



Please mention "The Hub" when you write.



# The Hub

Vol. LVIV

NEW YORK, JUNE, 1917

No. 3

Published Monthly by

## THE TRADE NEWS PUBLISHING CO. OF N. Y.

PAUL MORSE RICHARDS, *President* G. A. TANNER, *Secretary and Treasurer*  
EDISON BUILDING, COR. ELM AND DUANE STS., NEW YORK

THE HUB, a monthly authoritative journal on all subjects pertaining to the vehicle industry from its engineering and construction viewpoints. It publishes information of live interest to manufacturers of motor vehicles, trailers, carriages, wagons, the accessory trades, repair shops and garages.

Subscription price for the United States, Mexico, Cuba, Porto Rico, Guam, the Philippines, and the Hawaiian Islands, \$2.00; Canada, \$2.50; payable strictly in advance. Single copies, 25 cents. Remittances at risk of subscriber, unless by registered letter, or by draft, check, express or post-office order, payable to the order of THE TRADE NEWS PUBLISHING CO.

For advertising rates apply to the publishers. Advertisements must be acceptable to publishers. Copy for new advertisements must be received by the 25th of the preceding month. All communications must be accompanied by the full name and address of writer.

Entered in the New York Post Office as Second-class Matter

## General Business Conditions

The course of business has confirmed the opinion that war meant an increased stimulus to the industries, modified only by the necessity that under the pressure of more business than they can handle there must be contraction in some quarters in order that there may be expansion in others.

The great industries of the country, with steel leading, never before were under such pressure. Apparently the government requirements are proving to more of a factor than was anticipated; at any rate private consumers are competing so vigorously with each other for the remaining capacity that prices are still on a rising scale. The announcement that the British government has discontinued work upon the construction of a great new munitions factory for the reason that they would be able to buy more finished munitions in the United States shows the effect of granting credits and indicates that there is no end of this class of business except in the limit of our capacity. The departure of one engineering commission to Russia and another to France, and the announcement that several thousand picked railway men are to be sent to France to put the railways in order, are indications of enormous demands from those quarters.

Inquiries in the steel trade indicate an enormous booked up business. Most of them now are for the first half of 1918, but there is willingness to contract even into 1919, although on the basis of present prices this is highly speculative and steel makers discourage it. It is common opinion, however, that the iron and steel business is in for several years of full production, and the largest people in the trade are proceeding upon this theory.

According to the monthly bulletin of the National City Bank of New York, the weak spot in the industrial organ-

ization is the railroads. Nearly all the industries could do more if they were not hampered in getting necessary supplies and could get their products promptly out of the way. This is particularly true of the handling of coal and coke. The railroads are undoubtedly doing better, but the volume of traffic is in excess of their capacity. They need equipment and facilities of every kind, but perhaps their most pressing need is for locomotives, for the strenuous service of the past year has been hard upon motive power. Railway officials are putting forth every possible effort, operating all the railways as one system, so that surplus capacity on any line is brought into use. The volume of traffic actually handled is much beyond any past record. The gross earnings, as shown by Dun's Review, for the first two weeks of May were 11.3 per cent higher than for the same weeks of 1916, and as rates have not been raised in the meantime this means a corresponding increase of traffic.

With the advance of spring, retail trade has improved and there is little to suggest any curtailment on account of high prices. Reports have been current of the effect of economy in the textile trades, but whatever curtailment there has been in style goods has been quite lost in the demand for staple goods and for the government's wants.

The resumption of outdoor work increases the demand for labor, and there are complaints of shortage everywhere. Farm wages by the month are higher than ever before, made necessary by the competition of the town industries.

The good prospects now for the crops gives encouragement to hope that living expenses will at the worst be no higher next winter, and may be lower. If so the strain in the industrial situation will be in some degree relaxed.

## U. S. Leads World in Wealth

The per capita wealth of the United States is \$2,030; that of Great Britain, \$1,751; of France, \$1,522; Germany, \$1,355. Our present national debt is \$33 per capita, or will be after the \$1,800,000,000 war budget is passed; that of Great Britain, \$370; France, \$360; Germany, \$290. We could pay our debt 169 times over without being "broke." We have \$25,000,000,000 of "liquid" money, subject to check, in our bank deposits. Our trade balance in 1902 was \$478,000,000; in 1916 it was \$2,000,000,000, a 500 per cent increase in 14 years.

## Lake Boat Will Carry Motors Only

The steamer "Winnipeg," an old freighter, has been remodeled for the purpose of carrying automobiles on the great lakes. A new deck has been built in it, an elevator installed, and 150 cars will be carried at a time. She will operate generally between Toledo, O., and Buffalo, N. Y.

### Michigan Considering Ideal Road Law

A bill to regulate the weight, weight per inch of tire-speed, size and load distribution of all vehicles, including motor trucks, has been prepared for the Michigan legislature.

It applies to all vehicles, horse and motor alike, exempting motor busses, farm implement machinery and road-building appliances. It limits the gross weight to 15 tons, the rear axle weight to 75 per cent of that amount, the wheel track to 75 in., the total width to 8 ft., and the total height to 12½ ft. The speed limits are reasonable, that for a five-tonner being 14 miles per hour if provided with 36 in. wheels.

According to the wording of Section 8 the rear axle may not sustain more than three-quarters of the gross load. Improved roads in bad condition may be protected by posting signs restricting the weight to half that ordinarily allowed. It permits the use of chains but makes the user liable for any damage done to so-called improved roads regardless of their condition. Trucks are required to carry platee stating the wheel height, the tire width, the wheel track, the weight of the vehicle and the carrying capacity.

In the schedule of tire loads, horse vehicles are restricted to 600 lbs. per inch of width, motor vehicles approximately to 800 lbs., or the normal supporting capacity of rubber tires.

In the schedule of allowable weights, single tires only up to 7 in. in width are taken into account. The allowable speed on a single tire is slightly higher than that on a dual, but no allowance is made for a man with a ten, twelve or fourteen-inch single tire.

The bill is now under consideration by the legislature and was prepared by the State Highway Department of that state. The bill follows.

Sec. 1.—It shall be unlawful to operate any vehicle upon the public highways of this state, the gross weight of which exceeds 15 tons.

Sec. 2.—It shall be unlawful to operate any vehicle, except motor-driven vehicles, upon the highways of this state, the gross weight per inch width of tire of which exceeds 600 pounds.

Sec. 3.—In case a vehicle is equipped with a braking device said brakes shall be of a friction type and not of a type that will cause a deadlock of the wheels when applied.

Sec. 4.—No motor truck or trailers, hereafter operating upon the public highways of the state shall have a gauge of more than 75 inches measured from center of tire to center of tire and shall not be more than 96 inches wide over all nor over 12 ft. 6 in. in height.

Sec. 5.—No motor truck or trailers, hereafter operating upon the public highways of this state shall be equipped with driving wheels the tires of which are of metal that may come in contact with the surface of the road or which have a partial contact of the metal with the surface of the road, except where chains or other non-skidding devices are used; Provided, That should any improved highway be damaged by the use of chains or other non-skidding devices the person, company or corporation owning or operating such vehicle, shall be liable to arrest and penalties as hereinafter provided.

Sec. 6.—The following limits of sizes, weights and speeds of motor trucks and trailers shall be effective within this state for use upon the public highways:

Table for a Wheel 32 In. in Diameter

Size of Tire in Inches	Single Tire		Double Tire	
	Maximum Wheel Load in Pounds	Miles per Hour	Maximum Wheel Load in Pounds	Miles per Hour
2	700	20	1,400	18
2½	900	20	1,800	18
3	1,200	20	2,400	18
3½	1,600	20	3,200	16
4	1,900	18	3,800	14
5	2,200	16	4,400	13
6	2,700	14	5,400	12
7	3,200	12	6,400	10

For 34 in. wheel, multiply above max. wheel load figures by 1.1; 36 in., multiply by 1.2; 38 in., multiply by 1.3; 40 in., multiply by 1.4; 42 in., multiply by 1.5; 44 in., multiply by 1.6.

Sec. 7.—All motor trucks or trailers, now operating or hereinafter placed in operation, upon the public highways of this state shall have placed upon them information relative to their height of wheel, width of tire, gauge, width over all, weight, and carrying capacity. This information shall be conspicuously placed on the vehicle.

Sec. 8.—On the rear axle three-quarters of the gross weight of a motor truck or trailer and its respective carrying capacity must be within the limits of the schedule of the respective diameters of

wheel, size of tire, and speed per mile, as shown in the schedule under Sec. 6 of this act.

Sec. 9.—The front axle shall carry the remainder of the weight of a motor truck or trailer and load combined, and must be within the limits of the schedule for single tires under Sec. 6, this act.

Sec. 10.—This act shall apply to motor trucks or trailers used as buses for carrying passengers.

Sec. 11.—This act shall not apply to farm implements or machinery used in road construction.

Sec. 12.—The size of tire and height of wheel shall be taken as that size printed upon tire by the manufacturer.

Sec. 13.—Providing, That when a truck is hauling a trailer, the speed shall be governed by the vehicle having the lowest mile per hour rating.

Sec. 14.—During the months of March, April and May if, by reason of the thawing of frost or rains, the roads are in soft condition, the maximum carrying capacity of tires on all vehicles shall be limited to one-half the carrying capacity of tires as provided in this act. If at any other time any county, district, or township highway commissioner deems it necessary by reason of the soft condition of the roads to put the provisions of this act in force, he shall post notices on all improved highways to such effect, along with a copy of this section of this act.

Sec. 15 provides for a fine of not less than \$5 or more than \$50, or imprisonment in the county jail for not to exceed 30 days, or both fine and imprisonment, at the discretion of the court.

### May Need 2,000,000,000 Feet of Lumber for War Purposes

The Council of National Defense authorizes the following:

Estimates prepared by the lumber committee of the advisory commission of the Council of National Defense show that 2,000,000,000 feet may be used for purposes directly connected with the war in the next 12 months. Construction of the 16 cantonments which will house the new army will absorb a large amount of the government's lumber purchases. The cantonments will require about 500,000,000 feet. Second in quantity of lumber required comes the wooden ship building program now estimated at 400,000,000 feet.

"The best estimate that can be made of the total amount of lumber required for purposes of national defense within the next 12 months is 2,000,000,000 feet," says a statement issued by the committee. "This sounds like a colossal figure, and it is a big figure, but should give no apprehension that it will disturb the markets or cause a shortage of lumber. Actually this will not exceed 5 per cent of one year's lumber production of this country. It can readily be seen, therefore, that no lumber user need fear that it will be impossible for him to get the kinds and sizes of lumber needed for his particular purpose. We have the forest resources, and without doubt the producing capacity. If there is any difficulty at all it will be that of transportation, and we believe that transportation conditions now being adjusted will finally enable the carrying on of normal industrial operations with small variation from the ordinary course of business."

### Gear Manufacturers' Association Meets

The American Gear Manufacturers' Association held its first convention at the Hotel Schenley, Pittsburgh, Pa., on May 14 and 15.

The convention was opened by F. W. Sinram, president, with an executive session. In the afternoon of the first day, S. L. Nicholson, sales manager of the Westinghouse Electric & Mfg. Co., spoke on "The Ins and Outs of an Industrial Organization," and James E. Gleason presented a paper on "The Spiral or Curved Tooth Bevel Gear." On the morning of the second day the following papers were presented: "Job Gearing—To What Extent Can It Be Standardized," by Frank Burgess; "Advantages of Gear Standardization," by Wm. Ganschow. In the afternoon, George L. Markland discussed the difficulties of Gear Standardization."

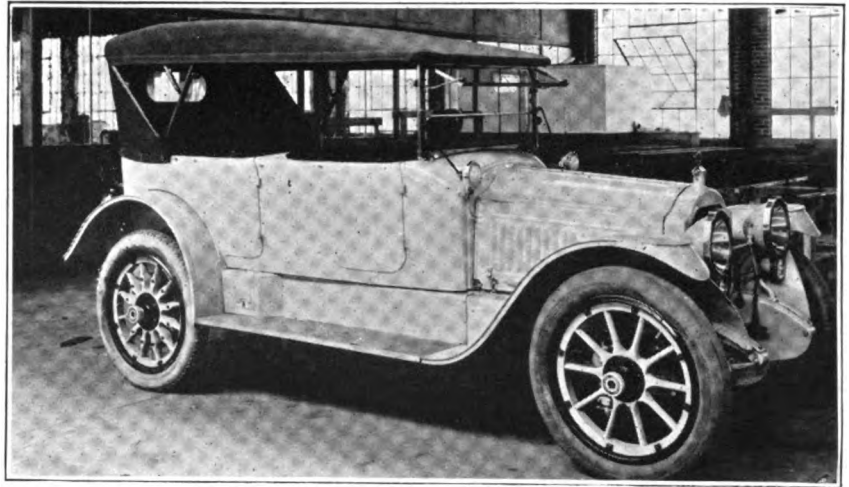

**TOURING CAR**  
Body built by FitzGibbon & Crisp, Trenton, N. J.  
Mounted on Packard chassis

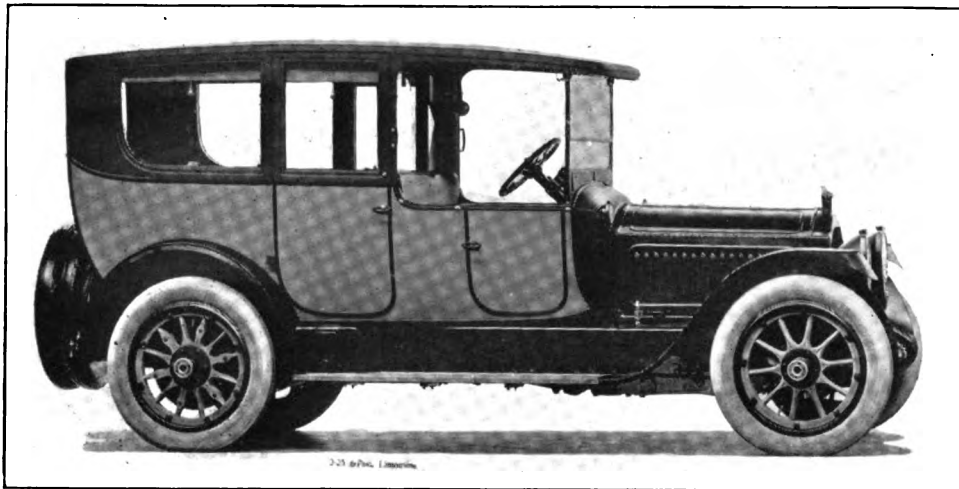

**SIX-PASSENGER LIMOUSINE**  
Built by Packard Motor Car Co., Detroit

Examples  
of  
Custom  
Body  
Work



**RUNABOUT**  
Body built by Mifflinburg (Pa.) Buggy Co.  
Mounted on Franklin chassis

### Science and the Foundry

It is only a few years since scientific knowledge in the person of the technical man was applied to the affairs of the brass foundry. The first men who dedicated their education and talents to this particular line of human endeavor are even now living, but in that comparatively short time a notable change has taken place in the methods of melting and alloying the metals used in the practice of brass founding.

Everyone will recall how this work used to be carried out, and will no doubt agree that the advent of the chemist with his inquisitiveness regarding the makeup of alloys, and the composition of those familiar and indispensable things known as supplies, was an acquisition not to be lightly regarded; but let us keep in mind the fact that analysis will not tell us everything, no matter how exact it may be, regarding the synthesis of any particular substance. In other words, we may be able to take a thing apart, but be utterly unable to put it together again. We know, for instance, how many atoms of carbon and hydrogen are combined to form gasoline, and how they are arranged, but so far the secret of putting them together to form this important fluid at will has not been mastered, although both carbon and hydrogen can be obtained in abundance. And this is not an isolated instance; in fact, the chemist knows that the things he cannot reproduce form the great majority of the substances he can analyze. And this, in a degree, is true of alloys; we may take them apart and thus know for a certainty their composition, but still be unable to put them together and get the physical properties of the original metal we analyzed. We have the body of the alloy we wanted, but it is minus the soul the other man put into it. A familiar example of this is manganese bronze. When this alloy first appeared everybody got an analysis, and everybody thought they could make it without trouble, but few succeeded for a long time. And even now, when the formula has been published time and again, and there is no secret about the "mixing alloy" used to carry the small percentages of iron, manganese and tin into the alloy, the great majority of brass founders fail oftener than they succeed in attaining the highest physical properties inherent in the alloy. And instances might be multiplied, but they all go to show that the chemist is not infallible. He may do his work well, he may tell us what is in the alloy, but his work does not show us how it was put together. He is a means to an end, like the metallographist, but only a means to an end, unless he has delved far deeper into the subject of alloys and alloying than the ordinary analytical chemist usually cares to go. Foundry work is dirty work, and he who would study the science of mixed metals on a commercial scale, and this is the only scale that counts, must get right into the grime and smoke of the foundry atmosphere and do his bit. The technical men who will do this, and do it for several years, are fitting themselves for successful careers as superintendents, managers, and owners, of the glorified foundries of the future, and will find themselves well repaid, not only in this world's goods, but in the consciousness of having performed their duty, and of having performed it well.

---

Balsa wood, found in Central America, is said to be the lightest known wood. It is lighter than cork and has an average specific gravity of only .104.

### C. B. N. A. Convention and Exhibition

Secretary Henry C. McLearn, of the Carriage Builders' National Association, has sent out to the trade the rules and regulations governing the exhibition which will be held in conjunction with the forty-fifth annual meeting of the association at the Hotel LaSalle in Chicago the week of September 24.

The exhibition will begin on Monday, the 24th, and continue through Friday, the 28th. The business meetings will be held on Tuesday, Wednesday and Thursday. All the different parts of the convention will be held in the Hotel LaSalle, including the business meetings, smoker, banquet and exhibition.

The Hotel LaSalle will furnish exhibitors, without cost, railings, chairs, mahogany and common tables, rockers and settees, and no other furniture will be necessary. Exhibitors are asked not to bring their own railings.

Admission to the exhibition hall will be by tickets which will be provided free to all active and associate members, also all carriage, wagon, sleigh, automobile and motor car builders who are not members; but not to any manufacturer or dealer in accessory goods who is not a member of the association. Badges will also be provided.

In fairness to those buying exhibition space, non-exhibitors are asked not to solicit trade in the hall. Exhibitors must be confined to models, parts of vehicles or automobiles, and to materials used in the construction of same, or to coachmen's outfits, harness and horse furnishings. No finished vehicle will be admitted.

Exhibitors will close their exhibits from 10:30 a. m. until 12 noon on Tuesday and Wednesday, so that the attendants and visitors may attend the business meetings.

Applications for space can be made through Henry C. McLearn, secretary, Mount Vernon, N. Y., and space will be assigned in the order of application.

Theodore Luth, president of the association, is making strenuous efforts for a record attendance. Cincinnati will send a large delegation.

---

### Bimel Wheel's Extensive Improvements

The Bimel Spoke & Auto Wheel Co. is completing extensive improvements to its plant at Portland, Ind., costing over \$60,000, consisting of six large new dry kilns of a total battery of eventually 12 kilns. Each of these kilns is 20 x 53. These kilns permit of drying spokes and felloes for small truck wheels at the rate of 400 sets a day. In all about three or four acres of new site have been secured, which makes the plant and grounds now cover about two and one-half city blocks. The other chief additions have been a new sprinkler system throughout, doubling of the rim planing and beading departments, etc. The capacity of the truck wheel department is now 175 to 200 sets of light and medium truck wheels per day.

---

### Repairing Motor Trucks in the Field

The Quartermaster General of the Army, Washington, D. C., has issued specifications, with a request for estimates, on machine shop equipment for repairing motor trucks in the field service of the quartermaster corps. The outfit includes a gasoline electric generating set for furnishing current for electric motor-driven machine tools, and for electric lighting, also a 13 in. screw cutting lathe, 18 in. drill press, portable forge, and a large assortment of machinists' and blacksmiths' small tools.

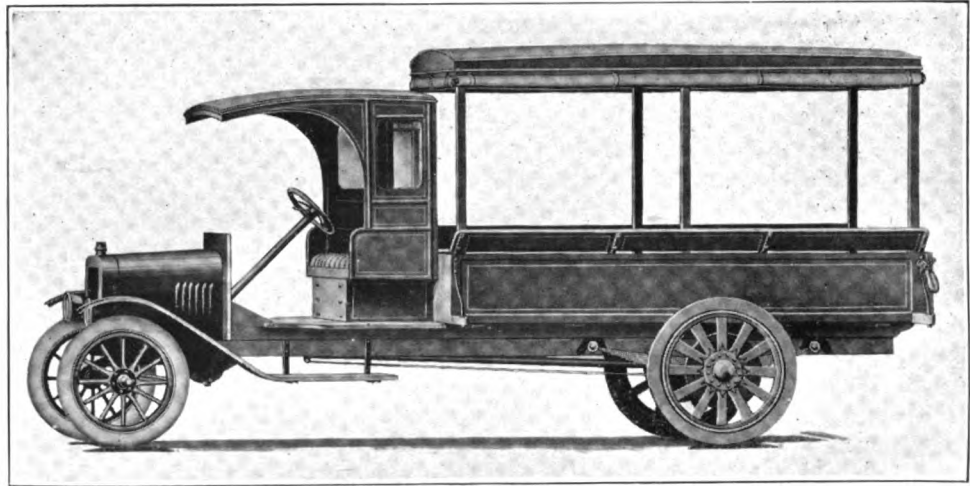

**NEW TYPE EXPRESS BODY ON A FORM-A-TRUCK CHASSIS**  
 Built by the Columbia (Pa.) Wagon Co.

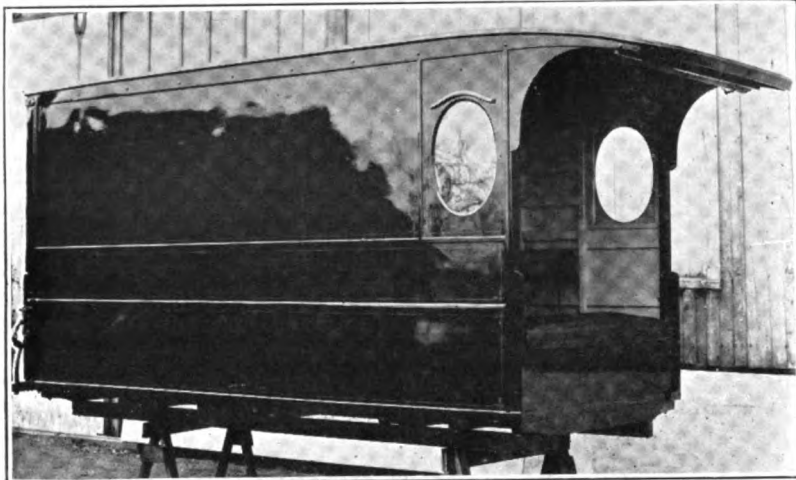

**DELIVERY CAR BODY**  
 Built by the Mifflinburg (Pa.) Buggy Co.

Specimens  
 of  
 Commercial  
 Body  
 Work



**SOLE LEATHER MANUFACTURER'S CAR**  
 Body designed and built by Brunn & Co., Buffalo

## Perlman Rim an Infringement on Munger Patent and Royalties Must Be Paid, Federal Court Decides

Federal Judge Manton has decided that a demountable rim made by the \$8,000,000 Perlman Rim Corp. infringes the patent on a rim owned by Louis de F. Munger, invented by him in December, 1899. The Perlman concern was ordered to account, before a master, for all the rims made in violation of the Munger design and to pay to Munger a reasonable royalty.

When Louis H. Perlman, head of the Perlman concern, was a witness June 10 in an infringement suit brought by the Perlman interests against the Firestone Tire & Rubber Co., he was asked by Martin W. Littleton, counsel for the Firestone, if he was not a fugitive from justice. He was pressed to tell whether he was the man who, under the name of J. B. Quint, was arrested in London in January, 1895. Perlman insisted that he could not remember what happened in London.

Perlman's counsel then gave notice they would withdraw the suit against the Firestone company. The questions put to Perlman as to his London career touch on his credibility as a witness. He had sworn that his rim, though patented in 1906, was invented by him in 1903. It was on that contention that Perlman last year won his rim infringement suit against the Standard Welding Co., of Cleveland, O., which netted him \$4,120,000 in royalties, it is said. After that success he formed the Perlman Rim Corp., absorbing the Standard.

The Munger patent was issued in 1899 to the International Wheel & Traction Co., to which he had assigned his rights. The International lacked capital at the outset and the rims were made for a while by the Munger Vehicle & Traction Co., at New Brunswick, N. J. Litigation with the Rubber Goods Mfg. Co. ensued, and the Munger rights next passed to the National Wheel & Traction Co. This was succeeded in 1902 by the Munger Automobile Tire Co., of Trenton. In 1915 the patent was assigned back to Munger individually.

The future of the Perlman Rim Corp. in regard to enforcing its patent has not yet been determined.

It is understood that L. H. Perlman, president of the Perlman Rim Corp., has retired from all connection with the corporation.

## Consolidated Motors Absorbs Thomas Auto Truck and Armored Motor Car

The Consolidated Motors Corp. has acquired the entire capital stock of the Thomas Auto Truck Co., and the Armored Motor Car Co., both of New York.

The corporation has also purchased a large steel and concrete plant in Schenectady, N. Y., located near the American Locomotive Works. This plant is being remodeled and when completed will be used for the manufacture of motor trucks, bodies and parts. Machinery is now being installed. The factory now has about 75,000 sq. ft. of space and additions and alterations already planned will give 25,000 sq. ft. more. The first floor will be devoted exclusively to assembly, the finished parts coming directly to this floor. The second will be used for storage and stock room. The upper floors will be used for manufacture and finishing of parts. The engineering, sales department and general offices will be located in the office building. A third two-story building will be used as a wood-

working and painting shop for the making and finishing of bodies. A patented body will be made here for Thomas trucks exclusively.

The New York City plant which has been in operation nearly two years, will be retained largely for local business and will build for and take care of the peculiar requirements of the local city trade.

The Armored Motor Car Co. controls various patents on the single and double revolving turret gun cars, a large number of which have been manufactured in Europe by special license, and are now doing service on the French and Russian fronts.

C. K. Thomas is president and general manager. He has been a prominent figure in the truck industry for 15 years.

## Annual Meeting of Electric Association

The Automotive Electric Association held its first annual meeting at the Homestead Hotel, Hot Springs, Va., on May 17-19. Members were present representing the following companies: Dayton Engineering Laboratories Co., Dayton, O.; Dyneto Electric Corporation, Syracuse, N. Y.; Electric Auto Lite Co., Toledo, O.; Leece-Neville Co., Cleveland, O.; North East Electric Co., Rochester, N. Y.; Remy Electric Co., Anderson, Ind.; Robbins & Myers Co., Springfield, O.; Splitdorf Electric Co., Newark, N. J.; U. S. Light and Heat Co., Niagara Falls, N. Y.; Wagner Electric & Mfg. Co., St. Louis, Mo.; Westinghouse Electric & Mfg. Co., Pittsburgh, Pa.

In his report appointing various sub-committees, the chairman of the standardization committee said that in view of the immediate prospect of the member companies being called upon to supply electrical equipment to the government for use on trucks and aeroplanes, an especially strong sub-committee had been appointed to consider questions pertaining to this work and to make such recommendations as may seem advisable from the standpoint giving the government the best and most prompt service possible.

The legal and patent committee reported upon efforts made to arrange some manner in which the patent situation could be amicably adjusted. It was stated that a preliminary investigation shows prospect of serious and extensive litigation involving many companies.

## Nut, Bolt and Rivet Makers Organize

A large number of leading makers of nuts, bolts and rivets have organized an association to be conducted on the Eddy plan, and known as the Bolt, Nut and Rivet Institute. The new organization already has 38 members, composed of the larger makers of nuts, bolts and rivets, and the next meeting will be held in the William Penn Hotel, Pittsburgh, June 26, when a large accession to its membership is expected. The new association will not deal with prices or labor conditions, but is formed solely for general betterment of conditions in the nut, bolt and rivet trades, which have not been satisfactory for a long time. Norris J. Clarke, secretary of the Upson Nut Co., Cleveland, is president; W. L. Comly, of the Russell, Burdsall & Ward Bolt and Nut Co., Port Chester, N. Y., is vice-president; W. T. Jones, of the Foster Bolt & Nut Co., Cleveland, treasurer, and Charles M. Best is secretary. The offices of the Institute are located in Rooms 227, 230 Oliver Building, Pittsburgh.



### Some Interesting Facts About Aluminum

As most of us know, aluminum is of extraordinary prevalence in nature, and is more abundant than any other metal, as it is said to constitute about 8 per cent of the earth's crust.

When aluminum was discovered by Michael Faraday in 1827 he had no idea what he was building up. As E. Carey Hill pointed out in his paper on "Aluminum in the Motor Industry," read before the Coventry (England) Engineering Society recently, 27 years elapsed before aluminum was obtained in a perfectly pure condition. There is no doubt that the early aluminum was very tricky and unsatisfactory from a manufacturing point of view. It was stoutly maintained by many of the old school of engineers that aluminum was dirt electrolytically persuaded to become a metal, but ever ready to revert to its original state, and therefore they placed no faith whatever in it.

However, as Mr. Hill pointed out in his paper, from 1906 onward a vast amount of scientific research has been conducted in connection with aluminum, and some of the results are given in the periodical reports of the Alloys Research Committee of the Institution of Mechanical Engineers. Mr. Hill suggested that still greater advances had been made since the outbreak of war, as aluminum plays so important a part in the construction of the aeroplane that it has been a constant subject of research at the National Physical Laboratory and elsewhere. The full results of these later researches and experiments can only be dealt with after the war.

As everyone knows, the outstanding property of aluminum is its lightness; in its pure state it is only slightly above one-third the weight of iron, volume for volume. It is too soft to be used in engineering design unalloyed, but when alloyed this softness is corrected and its density considerably increased. It does not corrode at all readily in its pure state, and even when alloyed a dry atmosphere has practically no effect upon it. One of the most difficult aspects of its handling in the foundry is that its contraction during cooling is rather high, amounting to about  $\frac{3}{16}$  in. to the foot, and this property creates a number of difficulties which the art of the founder has to overcome.

Foundry experience has taught aluminum casters that there are certain main principles that must be adhered to, even with alloys, if good results are to be obtained systematically, and the factors which govern these principles are (1) the high contraction of aluminum during cooling, (2) the peculiar stage of plasticity through which it passes between liquid and solid, similar to common solder; and (3) its very low density at high temperatures.

In all casting it is difficult, where there is any sudden variation of thickness, to ensure that uneven cooling will not set up stresses or absolute defects, and owing to the plasticity of the aluminum during cooling it is very apt to be pulled apart at the junction of a thicker portion

of the casting with a thinner part, and this is overcome by to, even with alloys, if good results are to be obtained systematically, and the factors which govern these principles are (1) the high contraction of aluminum during cooling, (2) the peculiar stage of plasticity through which it passes between liquid and solid, similar to common solder; and (3) its very low density at high temperatures.

In all casting it is difficult, where there is any sudden variation of thickness, to ensure that uneven cooling will not set up stresses or absolute defects, and owing to the plasticity of the aluminum during cooling it is very apt to be pulled apart at the junction of a thicker portion of the casting with a thinner part, and this is overcome by the scientific placing of "chills" in the mold on the face

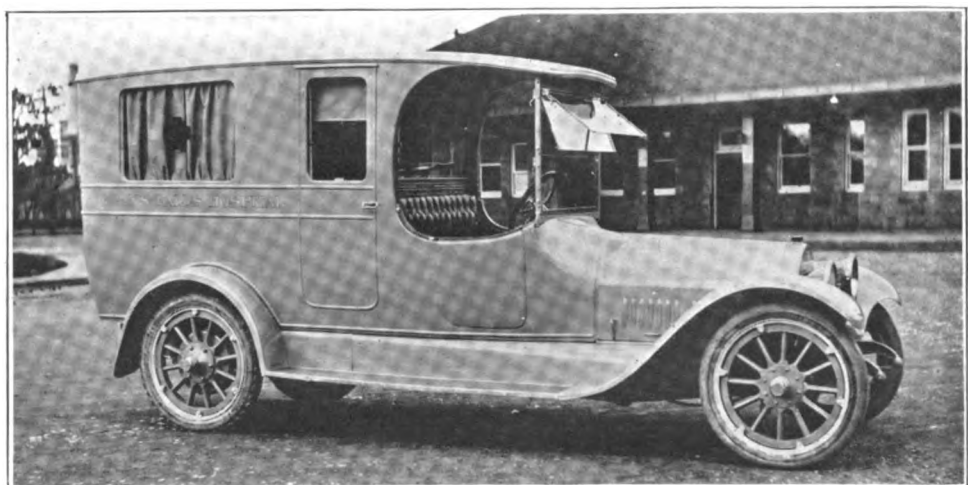
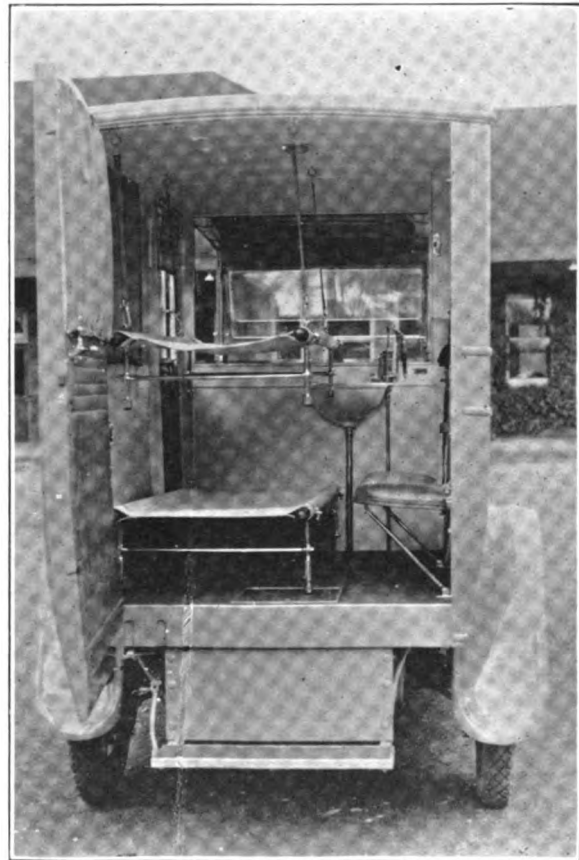

INTERIOR AND SIDE VIEWS OF HOSPITAL AMBULANCE  
Built by August Schubert Wagon Co., Oneida, N. Y.

of a thick portion. In other words, heat reduction is accelerated in the thick portion, so that it and the thin portion may cool approximately at the same rate—another proof, if proof be required, that there is no little similarity between the processes of geology and those of the foundry.

The alloying of metals is one of the most complicated chemical processes, because all sorts of things which are unexpected to the layman are encountered. For instance, pure aluminum melts at a temperature of about 660 deg. C., yet practically all the alloys commonly used rich in aluminum melt at a still lower temperature, though the addition of, say, copper is the addition of a metal which has a higher melting point than aluminum, and therefore at first sight it would be imagined that the melting point of the alloy would be higher than that of the pure aluminum.

The alloys of aluminum with copper are of particular interest because both in alloys rich in copper and alloys rich in aluminum are found alloys which have properties of great value to the engineer; those with a low percentage of aluminum are nearly uncorrodible by sea water either alone or when attached to steel, and are only slightly corrodible in fresh water. Then at the other end of the series there is the alloy with only 1 to 15 per cent copper and the rest aluminum, which is most valuable for many purposes. The alloys of aluminum, zinc, and copper have very considerable possibilities, and are used to a very large extent, but not so much research work has been conducted in regard to them as in the binary alloys, that is, the various proportions of copper and aluminum.

A number of other alloys were mentioned by Mr. Hill in his paper, but perhaps the most interesting referred to are manganese and magnesium.  $1\frac{1}{2}$  to 2 per cent of manganese with a small percentage of copper up to 4 or 5 per cent, and the rest aluminum, give an alloy with great hardness, and the lecturer mentioned that .2 to .4 per cent of manganese had been found in the alloys of which the angle and channel sections used in Zeppelin airship construction have been made. He also stated that the well known Vickers alloy "Duralumin" contained traces of manganese.

Perhaps, however, the greatest indication of future developments came in the reference to magnesium, which has been much advocated as the means of producing a strong light alloy of aluminum. Its very low specific gravity—1.75 to aluminum 2.56—obviously means that the greater the quantity of magnesium added to the aluminum the lighter the resultant alloy becomes. On the other hand, with the majority of aluminum alloys the additional metal increases the weight. Unfortunately at the present time magnesium is rather difficult to obtain, as well as being expensive, but it has great possibilities which may and probably will be exploited at some later time.

Mr. Hill dealt at some length with aluminum pistons, but in the main he dealt with facts already well known, though in regard to the aluminum alloy piston he brought up the interesting fact that the tensile strength of copper alloys falls rapidly as the temperature rises, and it is therefore clear that the heat conductivity of aluminum is a very real help to the piston itself in a way not usually borne in mind. It was pointed out, however, that the ideal is to find an alloy which, while maintaining all the other advantages of an aluminum alloy, would also have the property that its tensile strength up to a certain degree

would rise with the rise in temperature; such an alloy has indeed been discovered, but experiments are only in progress, and nothing more could be said about this. It will be realized that it is of the very greatest importance, because it follows necessarily that if an alloy in which rise in temperature increases strength can be successfully used, it is obvious that with the same margin of safety a still lighter piston can be used.

With regard to the working of aluminum pistons, Mr. Hill pointed out that they have been used most successfully with steel and cast iron cylinders, but on the whole better results were obtained in working aluminum against cast iron, as then, under suitable conditions, it was found that the walls assumed after long running just the same beautiful glaze as they do with cast iron pistons, and the wear was no greater than with cast iron.

Another interesting branch of the paper was in regard to die casting. Motorists hear a good deal about it nowadays, and they, in common with a good many engineers, are very hazy in their minds as to what it means, and we cannot do better than give the author's classification of the three distinct classes of the process, which are: (1) Casting under pressure into a mold which is entirely of metal (instead of the usual sand in which, of course, pressure could not be introduced); (2) casting without pressure into an entirely metal mold; (3) casting into a metal mold some part of which, such as a core, is of sand, because the nature of the casting is such that it could not be arranged in any other way.

The advantages of die casting are rapid production, accurate and uniform dimensions in the castings, thus reducing machining; a closer grain; increased strength in the metal in some cases; and last but not least an improved finish in the casting. So far as the motor car is concerned, die castings have been mainly employed for details such as magneto parts, electrical installation fittings and so on, but they can be used for crank cases, gear boxes, and other large parts. Of course, as compared with wooden patterns and sand molds the metal molds are a costly matter, and are only justified when a large number of similar castings are required from the same mold. Unquestionably the great advantage of the method is the splendid finish of the article, as the combination of pressure on the molten metal in the metal mold results in a smooth and clean exterior, which reduces the necessity for machining to an extent exactly proportionate to the perfection of the casting.

### Stanley Motor Expansion

The Stanley Motor Carriage Co., Newton, Mass., which was incorporated in April under Delaware laws with authorized capital of \$13,100,000, succeeds the former corporation of the same name, and capital stock to the amount of \$2,500,000 has been issued and the company reorganized in preparation for manufacturing on a greatly increased scale. Prescott Warren, formerly vice-president, becomes president, succeeding F. E. Stanley; Edward M. Hallet, formerly secretary, is treasurer, succeeding F. O. Stanley; Carleton F. Stanley remains vice-president of manufacture; and Frank Jay, western manager, becomes vice-president of sales. Charles Counselman and Arthur L. Goodwillie, of the Chicago banking house of Counselman & Co., are directors, representing the new financial interests.

# The Trailer and the Semi-Trailer; Their Uses and Their Advantages

The transfer and storage industry has successfully applied the motor truck to many of its haulage problems; it remains for the industry to adopt two forms of motorized transportation which are as yet new—the trailer and the semi-trailer. Both of these types of vehicles have numerous advantages which especially fit them for use by transfer and storage men. There are inherent values in them which, properly recognized and applied, will make the use of motor vehicles more economical and efficiently possible even where the motor truck itself has been unable to achieve an entry. The transfer and storage industry, more than any other, must seek to keep down its haulage costs and to perform its transportation work efficiently.

What is known as the semi-trailer is a six-wheeled vehicle. The body, which carries the load, rests upon a rocking fifth wheel placed over the rear axle of a shortened motor truck or a former pleasure car. The motor truck supplies the power partly to trail and partly to carry the load-carrying body. The origin of the semi-trailer lies in the principle that a motor vehicle can haul more than it can carry, and that in a motor truck the weight of the paying load is so distributed that most of it falls over the rear axle.

By utilizing this great rear axle weight-carrying ability and adding to it a second rear axle, the amount of tonnage that can be hauled in one load can be made unusually large. The shortened truck or former pleasure car which supplies the motive power may be of less capacity than would be required for even half the weight of the load that is to be carried in this manner, and consequently it may be a cheaper vehicle. For example, a one-ton motor truck with its wheel base properly shortened, coupled to a semi-trailer, makes a complete six-wheeled vehicle capable of carrying from three to four tons. As the load-carrying part of the equipment can be constructed much

more cheaply than a unit truck to carry the same load, and not even the addition of the one-ton truck will make up the difference in price, it will be seen that the first cost of such a vehicle would be small and consequently the charges of interest, depreciation, etc., would be much less.

However, these semi-trailers are somewhat more cumbersome than a unit five or six-ton motor truck and their use will never entirely supplant that of the unit truck. As with every other haulage accessory, these vehicles have their own particular field, their own varieties of work, to which they are especially adapted, and their use will be of greatest value in these limits. The transfer and storage industry will be able to use many vehicles of this semi-trailer class. They are especially valuable in carting anything of unusual length, such as lumber, and they can be used to advantage in hauling heavy material such as stone, marble, iron and steel, etc.

There are many haulage firms which cannot use a five-ton or a six-ton truck all the time. These firms do not wish to install a six-ton truck to haul two-ton loads even 50 per cent of the time. The expense is too great, consequently the one or two-ton truck is installed with the result that it is overloaded much of the time. This overloading is also expensive, fully as expensive in the long run as underloading. For this class of haulage companies the semi-trailer is the solution of a great problem. The semi-trailer can be installed with its tractive unit at approximately the cost of a one or two-ton truck, which makes it capable of carrying one or two-ton loads and not being underloaded in ratio to its expense of operation and maintenance. On the other hand, the semi-trailer will also handle the heavier loads at equal efficiency when called upon.

These things are true of general haulage. In the specialized field of household goods moving also, the semi-



*Courtesy Transfer and Storage*

Ton and a half Troy trailer and three and a half ton truck used by T. J. O'Reilly, of New York City



*Courtesy Transfer and Storage*

**Troy trailer and three and a half ton van in the service of the Pioneer Company. The trailer is a ton and a half vehicle**

trailer has many advantages. One of the problems of the small operator in the household goods moving field has been similar to that of the smaller firm whose difficulties were outlined above. Household goods are bulky but not heavy, except when crated. When crated and packed for shipment they weigh double what an uncrated load will weigh. The small operator has been in a quandary to provide a vehicle which would haul a load of household goods from a house to his packing room, and then take the same load from his packing room to the railroad station without suffering from an overload. Although the  $3\frac{1}{2}$  and 4-ton motor truck is too big and heavy for household moving except when the goods are crated, it has been necessary for the small operator to employ only trucks of this weight in order to take care of his crated shipments.

When working only on the removal of uncrated household goods, these vehicles are running at less than capacity, and therefore at less than their possible efficiency. Just as the small general haulage firm can use the semi-trailer for the solution of his problems, so may the small moving company turn to the semi-trailer for his own salvation. The semi-trailer will take care of the household moving and of the crated goods as well. It will be operating efficiently in ratio to its cost on uncrated household goods, and exceed that standard of efficiency on crated household furniture.

Another use to which the semi-trailer may be put in the household goods moving field, and a use which involves one of its greatest features of saving, has already been adopted by many members of the transfer and storage industry. In changing over from horses to motor vehicles the moving van operator refuses to scrap his former horse-drawn equipment. He wants to make the change to motor vehicles but is bound down to a gradual elimination of the horse through consideration of the amount of money represented in his old horse-drawn rolling stock.

However, by taking off the front wheels of a former

horse van, and adding a light truck or pleasure car for a tractor, with a rocking fifth wheel over its rear axle, the change can be very cheaply made. The horse-drawn equipment can then serve out its term of usefulness in this manner. Eventually, of course, it will be necessary to replace the plain bearing axles and iron-tired wheels by roller bearing axles and rubber-tired wheels, but this change can be cheaply made. In fact this change might be made at the very beginning to insure the maximum of life to the body and frame of the changed horse van.

One of these semi-trailers will track in behind the vehicle which draws it so that both tractor and trailer which make up the semi-trailer unit will run in a straight line. The wheels of the semi-trailer will take the same track all the way through; thus it is easy to turn corners and take curves. The large diameter fifth wheel prevents tipping of the trailer, and the rocking feature of the fifth wheel keeps all the wheels on the ground at the same time. The semi-trailer is not swayed from side to side because the vertical pivot—the king bolt—is directly over the rear axle.

Two or more of these trailers may be used with a single tractor, one trailer being left standing while the tractor maneuvers another trailer, etc. However, as these vehicles have no front wheels it is necessary to provide jacks or props for the front ends to rest upon. The difficulty in this arrangement is the length of time necessary in raising or lowering the jacks or putting the props under or removing them from under the vehicle. However, there is a type of vehicle on the market which carries four wheels and which is more adaptable to this kind of work than the semi-trailer. This is the unit trailer or four-wheel vehicle, which is also destined to have a big place in the transfer and storage industry.

Like the semi-trailer, the unit trailer or trailer, is founded upon the principle that a motor truck, like a railroad locomotive, can pull more than it can carry on its back. The unit trailer, however, unlike the semi-trailer, is added equipment. A user of this type of vehicle states that the



unit trailer provides capacity for an extra load at an increase of only 10 per cent in the cost of maintenance and operation. This user also says that the unit trailer in household goods moving is the vehicle which will make the gasoline motor truck a success in local city moving over comparatively short hauls.

The first unit trailer proposed was only slightly different from a horse-drawn wagon. It was believed that these wagons could be hitched on behind a motor truck as additional load-carrying space and that they would cost but very little. However, it was found that the horse wagon would not stand the increased speed of motor haulage. The vehicle trailed would side-sway. It would start with a jerk when the tractor truck started up and it would refuse to stop properly when the tractor truck stopped. It would not track behind the tractor truck and would swing out in going around corners. All of these difficulties had to be overcome and today the unit trailer is a much different vehicle than the horse wagon it was proposed to use at first.

First the vehicle had to be made stronger to withstand the increased speed and the strains to which such a trailer is subjected. Then it was necessary to provide for a uniform distribution of the pull of the tractor truck so that the trailer would not start with a jerk when the tractor truck started. This was accomplished by means of a spring in the drawbar which connects truck and trailer and by a system of drawing through the springs and from the center of the trailer. The vehicle had to be made to back properly and this was taken care of. The side sway was eliminated, and the trailer made to track behind the truck which draws it. Today the motor truck trailer is a special vehicle which is practically a truck without a motor, without steering apparatus, gears or transmission system; in short without any of the truly vital parts of the motor truck.

In the field of general haulage the trailer has many advantages. Just as in the case of the Pioneer Fireproof Storage Warehouses of Brooklyn, the trailer gives an increased load-carrying space at a cost increase of only 10 per cent, so it will do in general haulage. The trailer

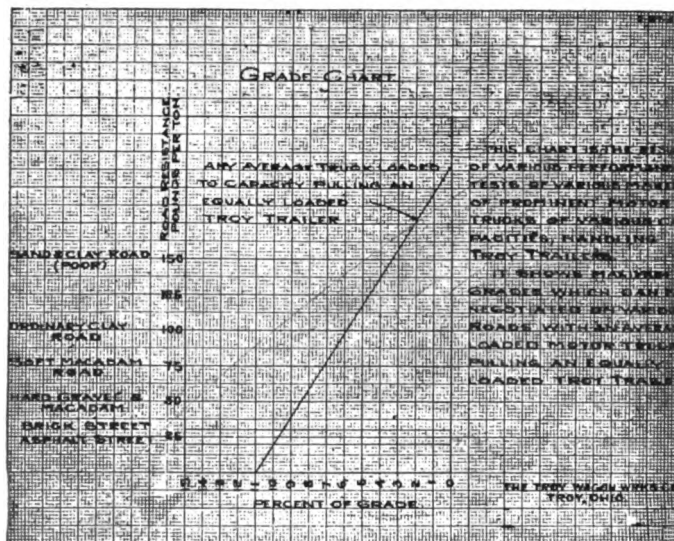

Courtesy Transfer and Storage

Grade chart gotten out by the Troy Trailer Co. to show when trailer of equal capacity with the truck may be used

may be hauled to a point where loading or unloading is slow and left to be loaded or unloaded while the expensive part of the equipment, the truck which draws it, is kept busy hauling a loaded or unloaded trailer to or from another point. The trailer may be sent with a truck to carry what would otherwise be a load for two trucks. The freight trucking firm which hauls to and from team tracks often leaves its wagons to be loaded or unloaded, taking the horses elsewhere to do other work. A motor truck and trailer can be handled in the same manner.

In the household goods moving business the trailer is very much at home. Very often a job of household goods moving will contain somewhat more goods than a single motor van can handle. While there will not be enough for two full vans, there will be more than the single van can carry. On such work as this a trailer will supply the lacking carrying space, and it is on such work as this that the trailer will make the gasoline motor truck a pos-



Courtesy Transfer and Storage

How Hookway's Warehouse Co. in Syracuse, N. Y., is using up its old horse vans with a light truck and a Martin fifth wheel



Courtesy Transfer and Storage

Semi-trailer equipment with a Packard shortened truck for tractor

sibility for purely local household goods moving. The advantages of this feature to the household goods mover in a small city where there is not sufficient inter-city motor moving to warrant the use of a gasoline vehicle all the time and where the hauls are too short for such a truck between out-of-town trips may easily be seen.

On a long distance, out-of-town job, the trailer presents the advantage of an added load as well as cutting down the number of men that must be sent with the goods. Two motor trucks going from one city to another would require two crews or at least four men, for a driver must not ride alone on a long trip. With a trailer only two men are required as no one rides on the trailer. The saving here is readily apparent. The extra help to unload the two vehicles may be obtained in the city where the loading or unloading is to be done. However, this advantage may not be so great inasmuch as a true safety-first policy would require that the trailer be equipped with brakes and that a crew of two men ride on the trailer as well as on the truck.

Very often a transfer and storage company has a load of household goods coming into storage or part of a moving job may be coming into storage. In such a case the trailer is a very valuable addition to a transportation equipment. The truck takes the load of goods on the moving part of the job while the things that are to be put in storage go into the trailer. The trailer is then dropped



Courtesy Transfer and Storage

Unit trailer with a Peerless truck

off at the warehouse to be unloaded while the truck goes on to the new residence. A good transportation or traffic manager can find hundreds of ways in which a trailer can be profitably used.

The household goods moving business is subject to great delays of loading and unloading, and in all places where there are delays of this kind the trailer will effect great saving. A trailer may be taken out and dropped off to be loaded while the truck goes on to pick up a load for itself. As long as the loading crew is about, the trailer will not be disturbed by the police, in most cities, as it is against police regulations only to leave unattended vehicles which have no motive power attached. One place in which the unit trailer can be most efficiently used is in hauling crated goods to freight terminals. Freight terminal delays are notorious and it is by the trailer that they can best be overcome.

A truck and trailer can take a load of crated goods to the car or freight station. The truck is unloaded first and goes back for another load or takes some nearby job, picking up the trailer when that is unloaded. Just as the semi-trailer will help the small truck owner who has occa-

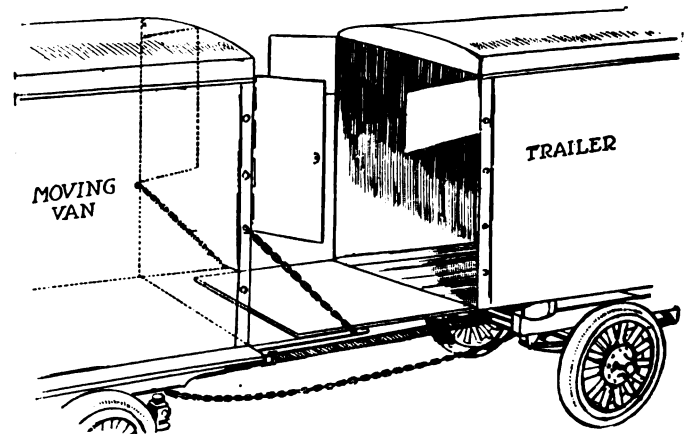

Courtesy Transfer and Storage

Showing how the tailgate of the truck and the drop door of the trailer form a loading platform

sional demands for a heavy truck and steady demands for only a light truck, so will the unit trailer take care of this kind of work, giving the additional load capacity necessary. In the smaller centers, where the small operator in the trucking business has a steady demand for only one or two trucks and a seasonable business which requires two or three trucks, so the trailer will fill the need as the extra equipment, at small expense.

When and how a trailer can be advantageously used are, of course, problems impossible to solve by general statements. As far as the purely haulage aspects of a particular problem are concerned the solution is fairly easy, being simply a matter of common sense and mathematics. But the big problem in deciding upon the use of a trailer is whether the trailer will be a success from a mechanical standpoint, whether the motor of the truck has the capacity to draw a trailer, whether a trailer of the same capacity of the truck can be used or whether local conditions are such that a trailer would not be a success. Trailers may be used with either gasoline or electric trucks, but local conditions of roads, grades, etc., govern the size of trailer that can be employed.

The Troy Wagon Works Co., Troy, O., one of the pioneers among the motor truck trailer manufacturers,





*Courtesy Transfer and Storage*

Trailer outfit used by the Murphy Transfer Co., which is working between St. Paul and Minneapolis

has made investigations to determine the factors which influence the selection of a trailer and their relative importance. This company has made charts which show the relation of the different factors and tell how to choose a trailer. However, the best advice that can be given a prospective trailer purchaser is not to attempt to analyze his problem himself. When he has decided that he should use a trailer, he should leave it to the trailer manufacturer to recommend the size of trailer best suited to his particular work and local conditions.

Over ideal road conditions, the grade chart worked out by the Troy Wagon Works Co. shows that a truck can haul a trailer of equal capacity to itself, both fully loaded, up any grade up to 10 per cent. These ideal road conditions are brick or asphalt pavement. The road resistance under such conditions is 25 lbs. per ton. However, in estimating how large a trailer may be used, the worst stretch of road and the heaviest grade over which the truck and trailer would have to pass must be taken as the conditions under which they will operate.

Using the chart of the Troy Wagon Works Co., it will be found that a soft macadam road offers a resistance of 75 lbs. to the ton. A truck will haul a trailer of its own capacity, both fully loaded, up a grade as high as 7 per cent over such a road, as the chart shows where the two lines from the type of road at the left, and the percentage of grade at the bottom, cross. Seventy-five pounds to the ton, means 375 lbs. of added weight in a five-ton trailer, however, and for a higher grade a smaller capacity trailer would have to be used. No matter what the road conditions are, a margin of safety would require that the trailer be of slightly less capacity than the truck which hauls it. The Pioneer Fireproof Storage Warehouse, of Brooklyn, N. Y., is using a two-ton trailer with 3½-ton motor vans.

The Pioneer Company and also the T. J. O'Reilly Storage Warehouse Co., of New York City, have adopted an idea in their trailers which adds greatly to their usefulness and efficiency. The trailer is what is known as a double-end trailer, it being possible to draw it from either end. Both ends are fitted with doors. Two-thirds of these doors are hinged at the bottom, letting down into the shape of a long tail gate. The remaining one-third opens to the sides. When truck and trailer are hitched together the door of the trailer may be let down upon the tailgate

of the truck, forming a substantial platform between the two vehicles. Upon this platform may be placed articles which are to be loaded into the van or into the trailer. The men working to load the vehicles take the goods from this improvised platform, while the men bringing the goods out from the house are not held up while the loaders are busy. Such devices as this render the trailer still more usable and still more of an advantage.

Both semi-trailer and trailer have their places in the transportation side of the transfer and storage business and both types of vehicles will be more and more adopted and used as time goes on. The transfer and storage industry is experimenting at present with different types of motor vehicles for its transportation. The 3½-ton truck is being abandoned by many van owners for lighter models, and some makeshifts and substitutes are finding their way into the industry. However, the industry can absorb and use practically every type of truck manufactured, so diverse are the haulage problems encountered. But the industry as a whole will some day do away with the heavy van body, use a lighter capacity truck and many semi-trailers and trailers which will in time be found invaluable.—Transfer and Storage.

### Billions Gallons Synthetic Gasoline in 1918

In a paper by Walter F. Rittman, read before the American Chemical Society, at Kansas City, in April, the author predicts one-fifth of all the gasoline produced in 1917 will be made by means of the cracking process. It is anticipated that 1,000,000,000 gallons of gasoline will be produced by one or the other of the cracking processes in 1918. Five methods for cracking oils will be available for the production of gasoline. Cracking in the liquid state, cracking in the gaseous state, cracking in the presence of a catalytic agent, cracking by the use of oil and steam, and finally cracking by a combination of all the mentioned methods. The gasoline demand will rise proportionately to the number of automobiles used.

Dr. Egloff in his addenda to this paper showed the possibilities of producing benzene and trinitro-toluene by cracking and re-cracking. This is entirely feasible if the gas standard is changed from an illuminating to a heating standard. If this is done \$25,000,000 may be saved annually in form of benzene, toluene and xylene.

### Plan for Electric Truck Service in Chicago

The Commonwealth Edison Co., of Chicago, has decided to offer to the public a complete garage and maintenance service for commercial electric vehicles at specific rates per annum on long term contracts. This service will be so comprehensive as to cover all the doubtful elements of transportation expense, and will thus enable any customer to determine in advance just what it will cost him per year to operate any size fleet of electric trucks.

The proposed service will cover the ordinary garaging or storage, including the cleaning and care of vehicles, the supply of energy for charging the battery and will provide for the maintenance or upkeep of the wearing parts of the vehicle, including tires, battery and mechanical parts. This maintenance will cover minor repairs of all kinds as well as the renewal of tires and battery when worn out. It will also include painting of the body at specified intervals, and provide for retouching and varnishing at intermediate times. The owner, however, pays the drivers' wages, insurance, and the cost of damage by accidents.

New trucks only will be accepted for the service. The rate for each size, equipped with standard battery, will be a flat figure per annum payable monthly in 12 equal parts. Trucks equipped with batteries of sizes larger than the standard will be charged for at proportionately higher rates. The working radius of the truck which the flat rate is intended to cover is that amount of service which can be procured from one charge of the battery daily. If the work to be done by the user should be greater than this and such as to require additional charging during the day, or the use of extra batteries, the flat rate above mentioned will be increased accordingly. Thus the whole system, while based on a flat rate for minimum service, is really a measured-service scheme depending upon the requirements of the user.

The Commonwealth Edison Co. is having a large service station erected at the corner of Jackson boulevard and Morgan street, a location which is very close to the trucking center just west of the main business or "loop" district. This building, which should be ready for use by the end of the summer, will render service to 100 electric trucks. Should this space be taken up quickly, additional space will be provided in the same neighborhood for a further trial of the proposed service.

The company is also planning to establish other service stations as the project develops, beginning with one on the north side and one on the south side of the loop district, if the first undertaking demonstrates a satisfactory demand for this type of service.

### Auto Makers Hold Annual Meeting

At a record gathering of automobile manufacturers with more than 90 companies represented, the National Automobile Chamber of Commerce members, June 7, reelected Charles Clifton, head of the Pierce-Arrow Motor Car Co., to the presidency. Other members elected were. Vice-president, Wilfred C. Leland, Cadillac; division vice-presidents, Hugh Chalmers, Chalmers; Windsor T. White, White; and Herbert H. Rice, Oakland; R. D. Chapin, Hudson, secretary; George Pope, treasurer, and Alfred Reeves, general manager.

John F. Dodge, of Dodge Bros., Detroit, was elected to the directorate, the others being Hugh Chalmers, Chal-

mers; R. D. Chapin, Hudson; C. W. Churchill, Winton; Charles Clifton, Pierce; J. Walter Drake, Hupp; C. C. Hanch, Studebaker; Wilfred C. Leland, Cadillac; Alvin Macauley, Packard; Wm. E. Metzger, Columbia; R. E. Olds, Reo; Carl H. Pelton, Maxwell; H. H. Rice, Oakland; Windsor T. White, White; John N. Willys, Overland.

The members voted \$39,000 of the organization's fund for Liberty Loan bonds and arranged to carry bonds for all employes who wished to subscribe.

Exports of American motor cars last year were more than \$96,000,000, and there is a growing appreciation in all countries of the service rendered at a minimum cost by the products of American makers.

The department will care for practically all general export matters, including information regarding shipping, embargoes, new tariffs, foreign dealers, trade opportunities and service for motor cars in foreign countries.

With few exceptions, every prominent manufacturer was represented, even including the Moreland Motor Truck Co., of Los Angeles, Cal., which was represented by its president, Watt L. Moreland.

### Fastening Hammer Heads

J. H. De Groot, instructor in shop work at the College of the City of New York, has developed a device for fastening the head of a hammer securely to the handle. This will best be understood by referring to the illustration of handle A without a head, where it will be seen that the method consists of drilling a hole through the handle in which are placed two nails with the heads cut

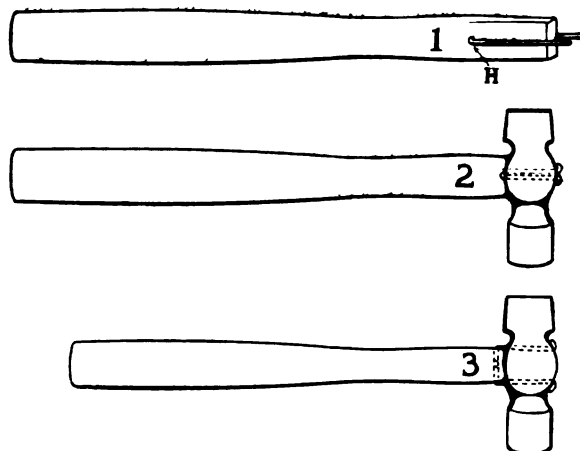

off and the ends bent over at right angles to enter the hole. Grooves are cut at each side of the handle, in which the nails lie flush with the surface and enable the end of the handle to be inserted in the hammer head in the usual way. The ends of these nails project out beyond the head of the hammer and are bent over, thus securing the hammer head firmly in place. At B the nails are placed in the handle as shown at A; and at C they are placed at the top and bottom of the handle, instead of at the sides.—E. K. H., in Machinery.

The scarcity of common labor has forced the Lansing, Mich., companies to employ women workers. Companies now employing them in large numbers are the Reo Motor Car Co., the Olds Motor Works, the Gier Pressed Steel Co., the Dail Steel Products Co., and the Lansing Stamping & Tool Co.

## Paint and Varnish

### The Profit of Good Car Painting

There is a great amount of cheap and tawdry painting of the automobile being put out at the present time, and in contrast with that of the good and dependable quality, the cheapness and inferiority of it becomes immediately apparent. Even with the cost of paint and varnish supplies quoted at a figure big enough to make the buyer pause and think twice before investing, it is manifestly certain that the cheap class of material is cheap not merely in price but in everything that enters into its composition. When it is considered that it costs just as much to have the cheap and inferior goods applied, in addition to putting the surface in a condition that eventually will require an extra expense to have it restored to its original shape, the folly of using the material with the price only to recommend it, is as plain as day. Good painting pays as well today as ever, and, if anything, a little better, because at the present prevailing prices of all commodities, including labor, better care will be given the equipment by the prudent and thrifty car owner, and with this care and attention, and with the application of a fresh coat of varnish a couple of times a year, the painting will be kept in a presentable condition long after the cheap class of work has gone to the discard. It is often wiser to simply touch the car up and revarnish it, using a superior grade of varnish, than to paint it with a cheap class of materials, lacking in substance and vitality, and then dressing the inferior goods over with a coat or two of varnish. Alone, this varnish might give a most excellent account of itself, but the varnish is never stronger than the base that supports it, and when the latter fails the varnish is bound to suffer in common. If the finish must for any logical reason be cheapened, it were better to make the supporting base, including the primary, surfacing, and color coats, of a fine and durable quality, and omit some of the varnish coats. In other words, we should greatly prefer to use fewer coats of material, making them of the best, than a flourishing show of stock of the cheaper sort applied in numbers conforming to accepted standards. Superior paint and varnish, handled by superior skill, pays in all work applied to the car. In appearance throughout the life of the finish it is an asset of supreme satisfaction, and in durability it has a value that reaches out over a prolonged span of service.

### The Fissuring Finish

The cracking of varnish upon the automobile is a condition that may be expected to occur either prematurely or in due course of time, the time given the car both on the road and in the garage, deciding the issue. The speed mania is responsible for much of the so-called force cracking of the finish, this being due in large part to the abnormal strain put upon it through the twisting and writhing and lurching of the machine. These force checks are found upon the metal car body quite to the same extent that they are found, and were formerly found, upon the wooden car body, because while there is greater rigidity

in the metal, it is none the less subject to the violent strain put upon the surface as the car lurches over thank-you-mams and scoop holes at a 40 mile an hour clip. These force checks are found at various points on the surface where the strain is most severe and persistent. Force checks are distinguished by their long circular, longitudinal fissures. With all such damage resulting to the surface the painter's skill, or lack of skill, for that matter, is not responsible, provided he has performed his work well, used good material, and given the car owner advice covering the care and usage of the finish.

In the matter of wood panels it is well known that moisture sometimes penetrates the wood, thus swelling the panels. Dry air shrinks the wood. When varnish is hardening, and thereby undergoing a change, it runs counter to the change going on in the wood, with the result that the varnish cracks. Not much of this sort of fissuring is going on at the present time, however, because the great majority of surfaces are metal. Very much of the cracking of varnish coming from natural causes—that is, from the wear upon the varnish—is due to allowing the finish to go too long unprotected after its protective resources have been exhausted. The remedy for this is simple enough, and may be expressed in the admonition: Varnish oftener, say, twice a year, at least.

A harder job is imposed upon varnish than ever before, because the car suffers a more severe form of service than any other vehicle running on wheels, and, if anything, is made to go longer without adequate varnish renewal than in all reason it is fair to ask. Then, too, if the varnish upon the car were renewed oftener, the paint and color could be made to last longer and look better, thus getting more value for the money invested.

### Touching Up and Varnishing the Car

It is not the easy job it may appear, for of all vehicles to wash and clean up for varnishing repairs, the automobile offers the hardest problem. Grease and waxy polishes and renovators used in keeping the finish "looking fine" are very hard, as a rule, to get off entirely, and to safely varnish over, this must be done. Hence, the first thing to do consists in getting the surface accumulations thoroughly out of the way. Hard grease is soluble in raw linseed oil, if allowed time to do its work; after which with turpentine used as a saturating medium in some clean waste, it can be taken off quite thoroughly. At all events, rubbing the surface with pulverized pumice stone and water will clear up the remaining atoms of grease, if any, and in addition it will help to clear off the waxy substances left through the use of renovators and polishes. Turpentine used as warm as it can be conveniently handled will serve as a solvent of the wax, and supplemented by the rubbing processes, should suffice, as a rule, to clear the way for the touching up work. This should be confined to the spots in urgent need of color, and then the pigment should be confined to the exact size of the defect. At the very best, it will be a hard matter to get the exact

match of the old color, so the least amount used, consistent with actual requirements, will be found the most desirable. It is a good plan to use a lettering pencil to do the touching up with; the color may then be used thinner and the size of the spot may be easier controlled and made more exact to requirements.

It will be well to carefully watch the corners of the panels about the moldings under which sediment and dirt sifts in, and from which it is with great difficulty removed. The washing up is a time for getting out a lot of this drift sediment, using a wash tool with the stock stiff enough to go under any slightly lifted molding, or into any crevice, for this purpose. At some of these points it is best to run a bit of shellac from the point of a pencil, lettering or striping, in a way to fasten all the threatening stuff securely and thus prevent it from working out over the surface during the varnishing process. If the surface shows more or less of fine fire checks, with a bite into the old finish too deep to be drowned out under the one coat of finishing varnish, a coat of rubbing varnish, as a matter of economy, as well as of good looks, had best be applied. Over this coat, after rubbing, the finishing coat of varnish will make a brave show and wear in great shape.

---

### Efficient Car Colors

It is said that certain reds are at the present time exceedingly hard to obtain. Not long since it was reported that a certain ingredient which enters into the composition of at least one particular red was so scarce that only about 500 lbs. remained in the country. Perhaps you have noticed that the red car is less in evidence than it was a couple of seasons ago which may be accepted as proof that some kinds of red are scarce, if not out of the market altogether. But why lament the loss, during the present emergency, of the bright reds, when there are so many other durable and attractive colors to be had. In the browns, for example, there are numerous beautiful shades which take kindly to striping effects, and which wear durably. These shades range all the way from the deep to the lighter tones. Lines of gold and black set these browns off handsomely. They are, on the whole, easy pigments to apply and bring out under varnish.

Then there are the gray pigments, practically all of which furnish durable and good looking fields of color, and when touched off with some striping effects their looks are immensely enhanced. French gray, possibly for sentimental reasons, leads the list in popularity; then there is automobile gray, olive gray, cadet gray, battleship gray, pearl gray, normal gray, etc. These grays are all helped by striping with contrasting pigments of a subdued tone, white, aluminum, light blue, and gold doing bravely in making the gray take on a finer tone. In the application of these colors it is advisable to have the pigments composing them thoroughly mixed, in order to guard against one ingredient asserting itself unduly and to the disadvantage of the other parts of the color. Gray often streaks out with the black composing it; hence, it should be kept well stirred in the container, following a very complete mixing at the bench.

The old standbys, blue and green, of the deeper shades and finer tones, are always in order, and for city-used cars they are unsurpassed in brilliancy and distinguished appearance. The striping effects best suited to these colors need hardly a word, for *The Hub* readers know, almost

instinctively, that lines of gold, black, carmine, orange, Naples yellow, and graduated stripes made up of the various tones of the field colors, add a richness and variety to the color scheme quite indispensable. After all, it is these quieter pigments which furnish the finest and most aristocratic effects.

---

### Bringing Up the Basic Coats

In all automobile painting the basic coats tell the story of the success or failure of the finish as a whole. Slight them ever so little and the finish suffers in an increased ratio; give them the care and fine attention which their importance justifies, and you bring an increased durability and brilliancy to the finish. Begin at the priming coat, if new work, and make it fit to stay in place and hold its position as long as the best pigment may be expected to stick; that is a start in the right direction. Bear in mind that the metal surface does not need as much oil in the priming coat as the wood surface invites; in fact, it cannot take care of it. It lacks properties of absorption. Less oil and gum constituent is needed, and more of the turpentine medium, which latter serves to take some of the oil and gum into the metal fibre to which it clings and holds forth the coats which come after. All these coats should be of the best quality, and they need to be placed with skill upon the surface. In the rush to get work out quickly there is danger of using the coats too heavy in body, in which condition they rough up and lay in brushy welts, thus making the work of leveling down under stone and paper much more difficult, if not impossible. The present practice is to use these coats thinner in body, brushing them out smooth, and thereby giving a finer knit body of pigment to rub and fetch down for the color.

It has been found that an extra coat or two of roughstuff is cheaper in the end than the less number of heavier coats of material with the correspondingly ridgy effect in the surface to rub out. Smooth and level coats of surfacer, both primer and roughstuff, pave the way for a smooth and level surface condition at a minimum labor cost, and also, in most cases, at a minimum cost for material. In bringing up the surfacing coats the puttying needs to be attended to upon the coat following the primer. Putty always holds better on this coat, and it is put down where it is well below the line of disturbance. Use a hard putty for all this work; apply it only where it is needed and to the extent needed, which is good puttying. A surplus of putty means simply an extra expense in sandpapering and rubbing down, and to the surface it is a harm rather than a benefit. Study the actual needs of the surface; apply enough surfacer to enable the work to be rubbed down to a level without stripping some parts of the surface dangerously close. A good uniform depth of pigment is needed to hold out the color and the varnish coats.

---

### F. H. Lawson Co.'s New Addition

The F. H. Lawson Co., Cincinnati, O., has under construction an addition that will increase its floor area nearly one-third, and with improved methods, 100 per cent increase in production. The plant when completed will occupy half of a city block, the present quarters wherein are made Lawco silencers, headlight deflectors and a line of fenders and special stampings, being five stories high.

### Beetle-Back Single Seater

The design here shown is of a sporting style, single seater body, generally known as a beetle back. It was recently built for a Melbourne gentleman, and mounted on a Stutz chassis. The car complete, has a very smart appearance on the road.

The construction is simple, if the drawing is followed carefully. The seat is wide enough to accommodate three people in comfort. The bottom sides are shaped as shown in plan, and are cut to suit the uprise over rear wheel. The layout of the pillars is shown in the side elevations, and when measuring the width of the bottom sides, allowance is to be made for the bevel, or width gained in the thickness. A crossbar is half-lapped to the sides in position shown, to carry the pillars which support the seat back rail. The crossbar at the back is half lapped,

plan and elevation. Battens are fitted between the two, and the scuttle dressed off to the shape shown. The door rockers are spliced in and the door made. This completes the outline of the front part of the body.

The boot is constructed next, by making three hoops, sizes shown in rear elevation; these are fitted into position and dressed to the necessary bevels. Battens are fitted between these hoops to show the side outline, and also to give the door opening. Three battens are fitted from the back bar to the rear hoop, to show the back shape, and the panels are fastened to these. The boot door is raised slightly above the level of the rest of the boot, to prevent the access of rain water. This is done by fitting a piece of wood round the inside of the opening, rabbeted  $\frac{3}{16}$  in. over the edge, and standing  $\frac{5}{16}$  in. above the frames. These pieces are fixed, after the panels are on.

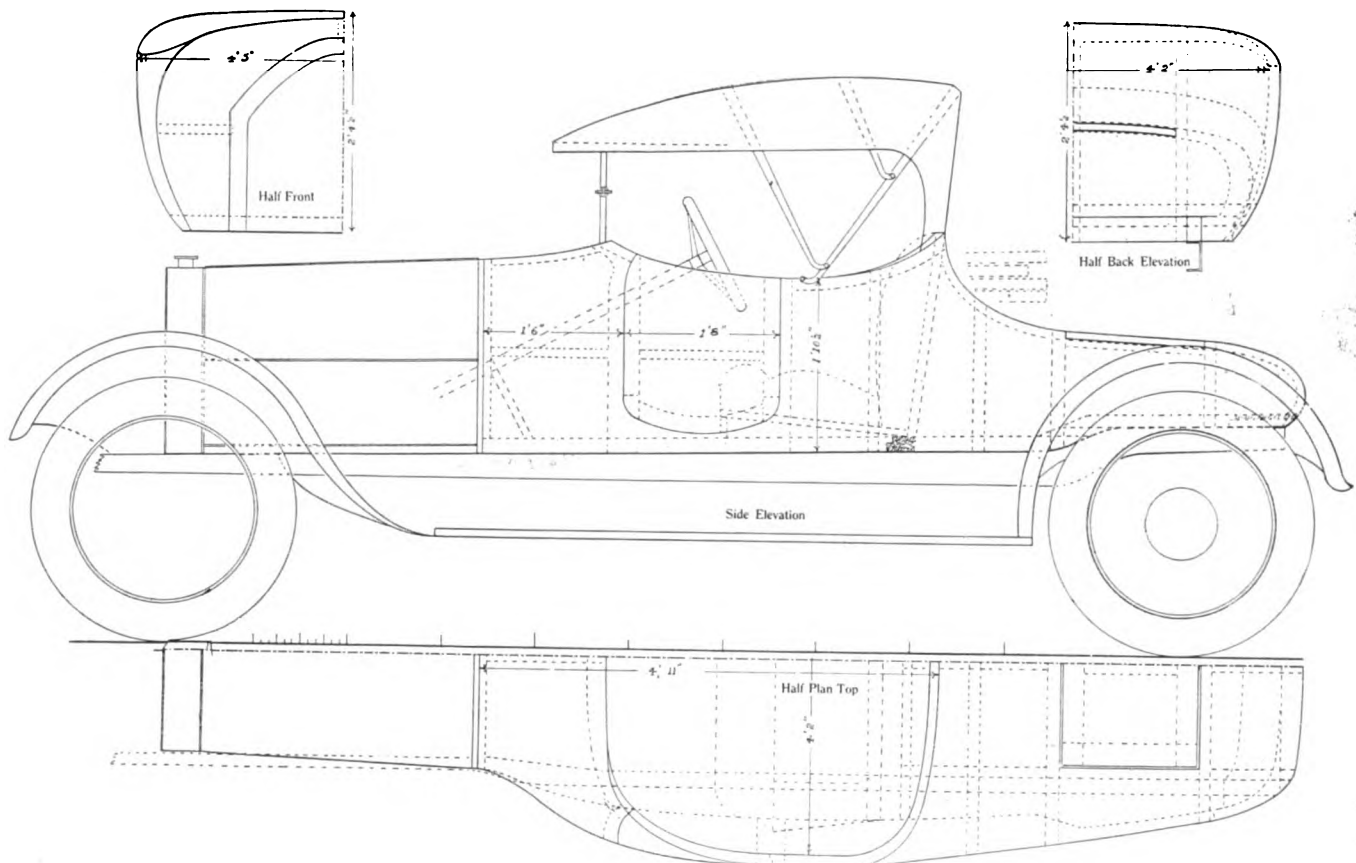

too, and is cut wide enough to allow for the round shape of the back. The inside of the bar can be cut to lighten the weight, as shown in ground plan. These rails are all rabbeted to the floor boards, which are  $\frac{5}{8}$  in. thick. The side pillars are cut and dressed to shape, and the door check rabbeted. The seat back pillars are cut straight, as they are not seen, and a slight layout for them is all that is necessary. The trimmer can adjust his squab to allow the necessary space behind wheel, and also is able to make a good soft springy cushion in this way. The top rail at the back is cut to allow for the shape where the boot takes off, and is therefore wider at the bottom than the top. The top side rail is fitted to the two side pillars, and the elbow corner is spliced to the two rails. The scuttle pillars are cut and fitted and the top cross rail screwed on. The dash frame is made to suit the shape of the bonnet, and the bevel allowed as shown in the

and then the rabbeted edge covers the edge of the panels. The inside of the boot framing is best, if lined with strips of three ply. This prevents anything inside the boot from bulging the panels. The door of the boot can be folded back and a dicky seat made of it, if it is considered necessary. The seat frame is made and fitted in position shown. It is well down on the floor, and consequently a good deep back support is allowed. The scuttle is finished with a polished panel inside, which carries the switches, clock, meters, etc. This being done, and the framing all dressed to shape, the panels are fitted. On this style of body all panels need hammering, and a good panel beater is necessary. The panels are screwed on, and all joints soldered and sweated together. The beading is fitted, and screwed, and filed off, and the door lapping adjusted. When this is done, the body is ready for the first coat of paint. Care should be taken when this is put on, that the iron has

been carefully cleaned, after the soldering, as the spirits sometimes eat through the paint and leave a nasty mark. The hood sticks are cut and dressed to the required lengths, and the body can be hauled to the smith. After he has made the necessary irons, the hood can be fitted up and all sticks adjusted to position. The screen is frameless, and is cut to shape, suiting the scuttle shape. The tool box is made and fitted on the side platform. The iron work being fixed, the body is handed over to the painters and trimmers for finishing.—Australasian Coachbuilder and Wheelwright.

### March Exports Nearly Double February

Reports from all ports in the United States show shipments totaling \$10,030,973 in trucks, passenger cars, and parts in March, compared with \$6,897,086 in February, and \$10,494,365 in March, 1916. Over half of these shipments were made through New York, where \$6,258,549 worth of trucks, cars and parts were shipped in March. Passenger car exports were increased nearly 66 2/3 per cent, while truck shipments were increased over 50 per cent.

The United Kingdom was our biggest buyer in March, her purchases increasing over \$1,500,000. Canada doubled her purchases during March, the total exports to that country being \$1,208,655, compared with \$526,767. Chile was our biggest buyer in South America, showing a large increase over the previous month. Argentina and Brazil also showed substantial gains. Australia tripled her purchases, being third largest in point of American automobile and truck purchases, which totaled \$365,527, compared with \$127,388 in February.

France and Russia fell off considerably in their purchases of American cars, France especially. Whether the large increase in English shipments has anything to do with the decrease in France is probable, but it is possible that many of the English trucks are shipped over to France. Russia fell off in the total value, but held the number of its purchases up to February's mark, increasing it by two.

For the eight months ending March, the United States shipped \$85,614,953 worth of automobiles, trucks, and parts, compared with \$89,722,953 in the corresponding period in 1916. Though the value decreased, the number of cars and trucks are practically the same, there being only a difference of three for the eight months, the balance being in favor of the 1916 period, when 55,140 were shipped.

### Ford Motor Co.'s Profit-Sharing Plan

More than three years have past since the inauguration of the profit-sharing plan of the Ford Motor Co., at Detroit, under which a minimum wage of \$5 a day is paid to employes who comply with certain conditions stipulated by the plan. The results of the profit-sharing scheme have been satisfactory to the company and to the men alike. At the end of the past year there were in all 55,752 employes of the Ford Motor Co. at the home factory and branch factories and offices. Of these about 42,400 were employed at the Detroit factory. When the profit-sharing plan was inaugurated three years ago there were 13,500 men on the Detroit factory payroll. In the year 1913 50,448 men left the employ of the company before the adoption of the profit-sharing plan. Last year, only 7,512 men left, and of these, 66 per cent had not been with the

company for the six months necessary to become profit sharers; hence, the profit-sharing system has largely increased the stability of the working force. Two years ago the accumulated savings and the property owned by Ford employes amounted to about \$18,000,000. At the end of the present year this sum had increased to about \$27,250,000. The company employs nine men in the legal department, which devotes a large share of its time to the interests of the employes. Legal counsel is given free, including advice regarding real estate purchases and investments, to between 150 and 200 employes daily. The medical department employs ten doctors, with 26 assistants, giving treatment, surgical and medical, to about 1,500 cases a day.

The third year under the profit-sharing plan has been a year of remarkable achievement for the Ford Motor Co. The annual business for the year ending July 31, 1916, was \$261,000,000. The standard of 500,000 cars set for production was passed, and during the last winter the factory has been turning out parts for 3,000 cars a day, which are shipped to the various assembling plants, only about 40 cars a day being assembled at the factory.

### Words of Affection From France

P. E. Ebrenz, general manager of the Reliance Buggy Co., St. Louis, and chairman of the executive committee of the Carriage Builders' National Association, has received the following letter from Paul Kellner, of Paris, France, who is president of the French Association of Carriage Builders:

"Just now at the time when the United States are about to enter into a struggle and they bring their mighty help to the Allies, who have been fighting for 32 months against German savagery, I want to express all the admiration that the members of our association feel for your great country, and I am really happy to be the interpreter in this expression of their sentiments.

"The victory, which our brave soldiers have gained by their bayonets and cannons is now more than certain, and we all express the hope that the value of the naval forces and military of the United States republic helping, this horrible war will soon end, with the German defeat, and will allow us to resume the peaceful run of our work.

"Be sure, my dear colleague, of the sincerity of our deep affection, and kindly accept the assurance of our most devoted sentiments."

### Allen Motors Forms Steel Company

Interests owning the Allen Motors Co., Fostoria, O., have organized the Fostoria Press Steel Co., with \$100,000 capital. Its officers are: President, Henry Rothrock; vice-president, George E. Kirk; secretary, E. C. Wolfe; treasurer and general manager, C. D. Pifer. The company will make pressed steel parts for the Allen car and do enameling and japanning in a 20,000 sq. ft. plant in the Allendale city addition that the Allen company is promoting.

### Death of F. H. Keys

Frank H. Keys, president of the Keys Bros., carriage manufacturers of Council Bluffs, Ia., died May 17 while sitting in a chair in a doctor's office, where he had gone for a consultation. He had been a sufferer from heart trouble for years, and his death was not unexpected.



### Overlapping Seats

The apparently impossible feat of accommodating three persons in a space which will in ordinary circumstances only seat two comfortably has been attained in the manner shown in the sketch. The driver's seat is built up separate, and the other portion is set back so that the middle passenger can sit partly behind the driver. The

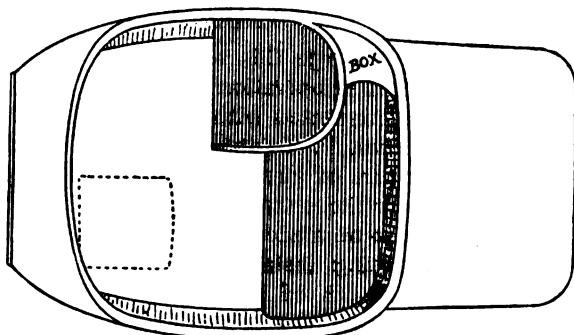

few inches extra length of body room necessary to carry out this idea makes no appreciable difference in the design. J. A. Munro & Co., Melbourne, Australia, have built several bodies to this design. In one instance by putting in a folding seat (shown in dotted lines) on the near side and a dicky seat in the boot they demonstrated the possibility of seating six persons in a single seater.

### Hardwood Supply Depleted

Hardwood dealers of St. Louis, Mo., who have in the past supplied much of the lumber for automobile manufacturers, are overwhelmed with inquiries and say the supply available for immediate shipping is unequal to the demand. They hope for relief from the recent order of the Interstate Commerce Commission ordering 13,000 freight cars into southern service, that number to be maintained by exchange of an empty for a loaded car.

Two-inch maple, which early in 1916 was quoted for Detroit delivery for \$26 per 1,000 ft., was sold at \$32 the first of the year, recently was quoted at \$35, and advance quotations are given at \$40.

First and second 2 in. ash, formerly used as the chief lumber for body building, is quoted at \$90 per 1,000 ft. in Detroit. Very little is obtainable.

Gum was sold as low as \$24 for 2 in. stock two years ago. It is being priced on future deliveries at \$41 and there is very little stock.

During the last few weeks thick oak, used chiefly by truck builders, has advanced rapidly.

### Eighty-seven Auto Firms Ready to Build Army Trucks

The War Department's request for bids for 35,000 army motor trucks brought responses from 87 concerns, and when the offers were opened June 20 it was found that the number for which bidders were ready to contract was many times the government's requirements. How many will be ordered has not been determined. The estimate of 35,000 made in asking for bids was based on the maximum transport needs of an army of 2,000,000 men.

Virtually all the big motor companies and many of the smaller concerns submitted bids. Many types and sizes were offered, the prices ranging from \$1,031 for one-ton trucks to \$4,600 for five-ton vehicles. Some of the manu-

facturers are ready to begin delivery at once and others set varying delivery rates, ranging up to six months in the future.

Three concerns—the Pierce-Arrow Motor Car Co., the Hurlburt Motor Truck Co., and the Nash Motors Co.—each offered to build the whole 35,000. Three companies offered to build trucks at cost plus 10 per cent profit. Offers to turn out 10 trucks a day came from two firms with no limit set on the total.

It is estimated that there are not more than 40,000 motor trucks on the Allies' western battle front in Europe, that number having proved ample for the needs of the British, French, and Belgian fighting forces. For this reason some officials feel that the War Department should not go above its estimate of 35,000 as the total to be ordered. It is expected that those offering quickest deliveries will receive preference in the placing of contracts.

### Carriage Makers' Club Outing

The great annual event of the Cincinnati Carriage Makers' Club was held at Laughery Island, June 9. The attendance was good. The committees had arranged an interesting series of events, consisting principally of athletic contests, including a base ball game. Theodore Luth, president of the C. B. N. A., was grand marshal. Entertainment committee: Jos. Wallenstein, C. J. Rennekamp, E. G. Shick, Harry McBride, Carl Kloos. Club officers: H. H. Nelson, president; Howard S. Cox, first vice-president; W. S. Rulison, second vice-president; E. E. Hess, treasurer; W. J. R. Alexander, secretary. Directors: H. H. Nelson, E. E. Hess, Howard S. Cox, W. J. R. Alexander, W. S. Rulison, E. M. Galbraith, Theodore Luth, H. W. McBride.

### Discontinue Making Mitchell Wagons

The directors of the Mitchell Wagon Co., Racine, Wis., have decided to discontinue the manufacture of wagons and have disposed of the greater part of the wagon stock which it was their policy to keep constantly on hand. The wagon business has been carried on by a separate and distinct corporation since the reorganization of the Mitchell Motors Co. two or three years ago. The wagon company is in sound financial condition and the decision to discontinue manufacturing is a result of present conditions in the wagon trade which have convinced the owners that it is not advisable to continue. Mitchell wagons have been among the leaders in high grade farm wagons for about 70 years.

### Cincinnati Vehicle Makers' May Meeting

The May meeting and dinner of the Carriage Makers' Club took place at "Heidelberg" on the evening of the 10th, with an attendance of 45 members and five guests. The speaker of the evening was R. E. Logsdon, publicity agent of the Chamber of Commerce, his subject being "The Personal Elements in Manufacturers' Advertising." Mr. Logsdon spoke at some length and gave out some very interesting facts in relation to advertising. E. E. Dudding, Huntington, W. Va., of the Prisoners' Relief Association, was also one of the speakers.

H. J. Hautz, of The American Carriage Co., was elected to membership in the club.

### The Refinements of Body Trimming

It is only fair statement to say that the automobile factories that lean to individual excellence of work, specializing in the refinements of trimmings, etc., for the distinction they confer on the finished job are at length adopting and making their own the fruits of experience that were as painstakingly acquired by the highest grade carriage builders through years of evolution.

The carriage builder's influence and requirements compelled the production by the supply (or accessory) trades of very high class products to meet the most exactly critical needs. As a result there grew up in the trade a small body of supply manufacturers whose artistic impulses were constantly fed by these requirements, and we have had, therefore, some very remarkable products coming from some of these manufacturers.

One of the oldest as well as most favorably known is the Bridgeport (Conn.) Coach Lace Co. Their looms have produced such rarely splendid fabrics in body trimming material that the name alone has been the hall-mark for all that is best. This sounds quite complimentary, probably, but it is one of the rare justifiable instances.

Since the demands of the auto body trimmer have made much more beautiful materials, fabrics and accessories the vogue, it has given the opportunity to do very artistic work, and naturally the Bridgeport establishment has been one of the chief purveyors. The scope of materials has widened; fine new fabrics heretofore unavailable have been brought forward, and where a builder has not been looking for something imitative and meretricious with which to squeeze through, he has had to go to the manufacturer whose taste and experience in making up such goods could and would fill the bill. Sorry this reads as if it might be too partial, but our knowledge of the business of coach trimming through the long years of *The Hub's* service in the trade has made us sensitive to worth and excellence and responsive to its demands. The Bridgeport goods are the real thing for the trimmer using fine materials.

### Finished Balls From the Raw Material

The New Departure Mfg. Co., Bristol, Conn., has added a new building, four stories high, with a total floor space of 178,000 sq. ft., or nearly two acres, for the manufacture of steel balls from the raw material.

Facilities have been provided for performing every operation. Raw material is received in the old ball building, which now forms part of the new plant. It is annealed, passed on to the wire drawing room, where it is sized and again annealed and sent to the heading machines. Twenty of the annealing furnaces are of the pit type, 11 ft. deep and the pots containing the balls are lowered into them by electric cranes. After cleaning, the balls are sent to the fourth floor for rough grinding, after which they are hardened.

In the hardening room all light is admitted through green winlows, to facilitate the observation of colors in the heated steel. Furnace temperatures are controlled by a pyrometer system, the details of which were developed largely in the New Departure engineering department. When properly heated the balls are quenched in deep vats which, resting on the third floor, project up through the fourth. This process results in excessive hardness and necessitates the next operation, which is tempering, and

is done in electrically heated muffles. The final grinding follows, leaving the balls polished and accurate to within one ten-thousandth of an inch. They are then turned over to a small army of girls who are expert at detecting superficial defects and who work in a clear north light. The final work consists of separating the balls into grades and accurately gauging them.

### Sandusky Forge Will Make Transmissions

The Sandusky (O.) Forge Co., recently organized, expects to place its plant in operation about July 1. It was formed by interests connected with the Salisbury Wheel & Axle Co., Jamestown, N. Y., and the Peru (Ind.) Auto Parts Co., both makers of automobile axles and wheels, to supply forgings for those two companies. Automobile transmissions will also be made and equipment for manufacturing these is being installed. The company will occupy about 6,000 sq. ft. of floor space in the factory formerly occupied by the People's Portland Cement Co. About 12 hammers, ranging from 2,000 lbs. to 7,000 lbs. capacity, will be installed. R. J. Barrows is president; M. E. Crowe, vice-president; and W. H. Collier, secretary and treasurer.

### England Door Patent Invalid

The England patent, No. 1,008,805, covering a metal automobile door having a flange projecting over the crack between door and body, has been held invalid for lack of invention. This is the decision of the United States Circuit Court of Appeals, sitting in the appeal of the Edward G. Budd Mfg. Co., Philadelphia, Pa., from the decision of the lower court holding it to have infringed the patent, owned by the England Mfg. Co. The court held that the making of the flange and door panel one piece of metal was not invention, being the exercise of nothing more than the "common knowledge and skill of the sheet metal worker."

### To Make Trailer With Automatic Brake

The Automatic Control Trailer Co. has been formed at Columbus, O., with \$25,000 capital to engage in the manufacture of trailers and equip trailers with a braking device that works automatically. The device is covered by patents which are controlled by the company and works on all grades, eliminating any danger from the operation of trailers without brakes.

The incorporators are: H. C. Rogers, John H. Price, S. A. Kinnear, C. W. Seaman and John G. Price. The Broad Oak Garage, which was recently purchased by H. C. Rogers, will be used as a plant.

### Peters & Herron Dash Makes Complete Change

The Peters & Herron Dash Co., Columbus, O., well known in the carriage trade as a large manufacturer of dashes, has made a complete change of its product. Some time since it sold its entire dash business to the McKinnon Dash Co., of Buffalo, remodeled its entire plant and installed machinery for the production of auto seats, tire covers, radiator robes and other auto accessories.

Harry B. Staver, president of the Staver Carriage Co., Chicago, was appointed receiver for the Drexel Motor Car Corp., June 11, by Federal Judge Carpenter.

# Vehicle Industry News in Brief

## Truck Builders

Cadillac (Mich.) Auto Truck Co. has increased its capital stock from \$200,000 to \$350,000.

Republic Motor Truck Co., Alma, Mich., contemplates erecting a factory building this summer at an estimated cost of \$750,000.

Commercial Car Construction Co., Sacramento, has been organized by S. D. Rogers and others to manufacture a new type of motor car.

Moreland Truck Co., Los Angeles, manufacturer of motor trucks, has awarded a contract for a new one-story machine shop, 35 x 134 ft.

Hahn Motor Truck & Wagon Co., Reading, Pa., will build the first unit of its factory building 52 x 192 ft. This will be known as the chassis assembling building.

J. C. Wilson Co., Detroit, voted to increase the capital stock to \$1,000,000 to take care of the increase in the motor truck business and provide for further expansion.

Maccar Truck Co., Scranton, Pa., is taking bids for a one-story reinforced concrete factory, 70 x 300 ft., to cost \$90,000. A power house for plant operation is also planned.

Lane Truck Co., Kalamazoo, Mich., is manufacturing a 3½-ton truck, selling at \$3,000. Company will also engage in the manufacture of 1½-ton truck in the near future.

Federal Motor Truck Co., Detroit, has completed additions to its stock and manufacturing buildings and 500 feet of additional railroad loading platforms have been installed.

Briscoe Motor Corp., Jackson, Mich., looks to the early marketing of a light delivery truck, which will incorporate in its chassis the distinctive Redden features, using a Briscoe engine.

Racine (Wis.) Motor Truck Co., incorporated recently, capital \$50,000, has elected Ira L. Miller president, and B. F. Henline secretary-treasurer. Manufacturing plans are now maturing.

Menominee (Mich.) Motor Truck Co. has closed a contract for \$2,000,000 worth of motor trucks for exportation to Russia. Plans are being made to increase the facilities and to enlarge the working force from 100 to 150 men.

The motor truck department of the Peerless Motor Car Co., Cleveland, is employed to about its full capacity in trucks for England at the rate of 15 a day, and it is expected that these orders will keep it busy for an indefinite time.

Conestoga Motor Truck Co., Philadelphia, has incorporated in Delaware, capital \$1,000,000, to manufacture motor trucks and automobiles. W. C. Arnold, Frank J. Riera, Jr., and H. Wolfenden, Philadelphia, are the incorporators.

Republic Motor Truck Co., Alma, Mich., is considering

the erection of a plant at Los Angeles for assembling work. The first unit of the proposed factory is estimated to cost about \$150,000, and will give employment to about 250 workmen.

Vim Motor Truck Co.'s 800 employes, Philadelphia and Pittsburgh, Pa., have been granted an increase of 10 per cent in wages. A reduction of the working time two hours and a half a week was also granted with no reduction in the rate of pay.

Stewart Motor Corp., Buffalo, N. Y., has added a two-ton truck to its series, making a total of four models. The company will build an addition, 40 x 124 ft., to its plant at East Delavan avenue and the New York Central Railroad Belt Line.

Clyde (O.) Cars Co., formed as a result of the recent merger of the Krebs Commercial Car Co., the Clyde Cars Co., and the Lincoln Motor Truck Co., will produce six models, including 5, 3½, 2, 1½, ¾ and 1-tonners, to be known as the Clydesdale.

Capitol Motors Corp. has been organized at Fall River, Mass., with \$250,000 capital to manufacture a full line of motor trucks, which will be built in ½, 1, 2, 3½ and 5-ton capacities. Incorporators: William Krafve, John B. Quinn, Alcid A. Barabe and Chester T. W. Sutcliffe.

Jewett Truck Attachment Co., Newark, O., has been incorporated, capital \$25,000, to manufacture attachments for all makes of trucks. The factory is to be established at Newark. Incorporators: William B. Wingerter, William S. Wright, William Schroeder, Bessie B. Wright and Edward Kibler.

L. & B. Truck Mfg. Co., Los Angeles, has been incorporated, capital \$35,000, to manufacture motor truck attachments and transmission apparatus. The company is now building a new plant at 54th street and Boyle avenue. H. L. and William P. Bidelman, C. R. Crump and C. B. McCall are incorporators.

Winther Motor Truck Co., Kenosha, Wis., organized several months ago by M. P. Winther, formerly of the Thomas B. Jeffery Co., to manufacture motor trucks, has located at Winthrop Harbor, Ill., just south of Kenosha, where an existing plant is being rebuilt. A new office building is also under construction.

Steamotor Truck Co. has been formed in Chicago, with \$3,000,000 capital stock. It has secured a license under the Doble patents from the General Engineering Co., and is planning manufacturing on an extensive scale, contemplating an ultimate production of 150 a day. The truck is to be known as the Steamotor, and will carry two tons.

## Body Builders

H. Russell Brand has been appointed business engineer of the Springfield Body Corp., Detroit.

Wright Carriage Body Co., Moline, Ill., has increased its capital stock from \$150,000 to \$300,000.

J. F. Field Co., truck bodies, Alma, Mich., will build a one-story factory and office building, 60 x 300 ft.

Briggs Mfg. Co., body builders, Detroit, has increased its capital from \$50,000 to \$75,000, to enlarge its manufacturing facilities.

R. F. Anderson will become body engineer of the Hayes-Ionia Co., Ionia, Mich. He was formerly in the body engineering department of the Packard Motor Car Co.

Porter Body Co., manufacturer of commercial bodies, formerly of Ypsilanti, Mich., has moved to the plant formerly occupied by the American Furniture Co., Ann Arbor, Mich.

Fleetwood (Pa.) Metal Body Co., manufacturer of metal automobile bodies and parts, is having plans prepared for a three-story addition, 60 x 125 ft. Fire destroyed part of its plant June 5.

Barnett Auto Body Co., Portland, Ore., is building a new plant in that city. At present the company is conducting its manufacturing operations in the Pacific Storage Co.'s building.

G. W. Stratton Co., manufacturer of detachable winter tops, 2429 South Michigan avenue, Chicago, is branching out into production of bodies for taxicabs. Contracts are reported as coming in in goodly volume.

Saginaw (Mich.) Auto Body Co. has been incorporated with a capital stock of \$100,000, and will start work shortly in the plant formerly occupied by the Feige Desk Co. S. L. Eastman is prominent in the enterprise.

Detroit Weatherproof Body Co. has leased five factory buildings in Pontiac, Mich., known as the Flanders group, containing 85,000 sq. ft., and is now moving its equipment to that city. The executive offices will be maintained in Detroit. Samuel T. Douglas is president.

With the centralizing of manufacture of Springfield bodies in the Detroit plant of the Springfield Body Corp. and the closing of its factory at Springfield, Mass., John R. Ide, assistant sales manager, has returned to Detroit. Ide has been in charge of the Springfield plant.

Maibohm Motors Co., Racine, Wis., is completing the installation of equipment for the manufacture of its own bodies. When the installation is complete, the company will make known a number of new body styles; at the present time production is confined to a two-passenger roadster which sells for \$795.

Parry Mfg. Co., Indianapolis, Ind., makers of commercial bodies for Fords, Maxwells and other light chassis, last month shipped a large number of commercial bodies for Maxwell cars to Buenos Aires and also several dozen one-man tops for Ford touring cars to Valparaiso, Chili. Shipments to Cuba are also being made on a regular weekly schedule.

D. B. Dunham & Son, Inc., 291 Halsey street, Newark, N. J., manufacturer of automobile bodies, has acquired property on Miller street for a new plant, replacing a former factory on Central avenue, destroyed by fire. The building, 70 x 300 ft., will be used for sheet metal work, blacksmithing, wood working, trimming and other departments. A connecting office building is being erected.

All Season Body Co. has purchased on contract the plant of the Page Bros. Buggy Co. at Marshall, Mich., and will manufacture detachable tops and bodies for automobiles. The company has contracts for 7,500 touring cars and 1,600 roadsters with the Briscoe Motor Corp. A. H.

Whitmore, at one time holding an important position in the body department of the Packard Motor Co., has been elected president.

Dale Body Co., a subsidiary of the Allen Motor Co., in the Allendale section of Fostoria, O., is expected to have work completed by July 1 on its new plant now under construction. Upward of 30,000 sq. ft. of floor space will be available, enough to turn out 100 bodies daily. There will be plenty of glass in the sides of the building for illumination, the latest body-making machinery, sprinkler protection and other facilities.

### Parts Makers

Torbensen Axle Co., Cleveland, is building a new addition with 30,000 sq. ft. of space.

Improved Windshield Mfg. Co., Louisville, has been incorporated, capital \$30,000, by W. R. Shacklette, J. Bauer and D. T. Duckwall, Jr.

Hess-Pontiac Spring & Axle Co., Pontiac, Mich., a subsidiary of the Standard Parts Co. will spend \$50,000 on new additions and will employ 200 more men.

Progress Auto Equipment Co., Detroit, has been organized, capital \$50,000, to manufacture automobile parts. Those interested are Carl Torgl, O. H. Schnepfer and Herman A. Schmidt.

Quickwork Company, maker of sheet metal working machinery, which recently removed its plant from Detroit to St. Marys, O., will remove its offices to St. Marys and enlarge its manufacturing facilities.

Canton (O.) Rim Co. has been formed with a capital of \$100,000. William P. Beardsley, A. R. Turnbull, Henry R. Bauhof, Grover C. Allison, John G. Smith, and Thomas Llewellyn, Jr., are the incorporators.

Lapeer Pressed Steel Axle Co., recently organized at Lapeer, Mich., with \$50,000 capital, will put a new pressed steel axle on the market. Machinery is said to have been shipped already, and production will begin as soon as it is installed.

Covert Gear Co. has taken over the former plant of the Gray Motor Co., which has a floor space of 56,000 sq. ft., and will use this factory to manufacture, in Detroit, about twice as many transmissions as are made in the Lockport, N. Y., factory.

LeRoi Co., Milwaukee, gasoline engines and automobile motors, has started erection of a one-story machine shop addition, 80 x 170 ft., at Sixtieth avenue and Mitchell street, West Allis. It will be of brick, concrete and steel, with saw-tooth roof. Charles W. Pendock is general manager.

Bound Brook (N. J.) Oil-less Bearing Co. has awarded contract for a new foundry to be erected at Lincoln, N. J., two miles east of the Bound Brook plant. New building will be of steel and brick 60 x 180 ft. It will be two stories high and modern in every respect. This addition has been made necessary by the rapidly increasing business of the firm.

Cleveland (O.) Welding & Mfg Co. is making additions to its plant. One building providing 50,000 sq. ft. of floor space for making light rims for automobiles is well under way, and the erection of another of about the same size for making bands, has been started. Completion will be rushed in order to take care of the large line of business growing out of government orders for war trucks.

## Car Builders

Chevrolet Motor Co. is to erect a new factory at Salt Lake City, Utah.

Jackson (Mich.) Motor Car Corp., it is reported, will establish a plant in Windsor, Ont.

Oakland Motor Car Co., Pontiac, Mich., is completing the erection of a new engine plant.

Consolidated Motors Corp., Philadelphia, has increased its capital from \$1,500,000 to \$2,500,000 for expansion.

Napoleon (O.) Motor Co. will move its plant to Traverse City, Mich. The company states that it has orders for 5,000 passenger cars and 300 trucks.

Macon (Mo.) Motor Car Co.'s plant was burned May 16, with a loss of \$350,000. Plans for reconstruction have not been determined upon. H. C. Finck, St. Louis, is president.

Fageol Motors Co., San Francisco, is to begin work on the first unit of its factory at Oakland, on the east shore of San Francisco bay. The auto and truck plant will ultimately cost \$1,000,000.

Peerless Motor Car Co., Cleveland, has completed extensions to be used for the manufacture of pleasure cars, and has commenced the erection of a warehouse, 48 x 400 ft. It will shortly require a 750 h. p. boiler.

Templar Motors Corp., Cleveland, has commenced the erection of a one-story building, which will be the first unit of its plant. The manufacture of motor cars will begin in about 30 days. M. F. Bramley is president.

Crow-Elkhart Motor Co., Elkhart, Ind., has purchased a factory site of 26 acres adjoining the company's present plant and several extensions will be erected. The company recently completed a new administration building, and a wood working plant, which cost \$20,000. Two additional structures are to be erected in near future which will be used for the manufacture of a new line of convertible five-passenger cars the company expects to place on the market.

## Miscellaneous

Butte (Mont.) Carriage Works will erect a two-story concrete machine shop and garage, 75 x 112 ft., to cost \$22,500.

Kentucky Wagon Mfg. Co., Louisville, will erect a forge shop to cost about \$50,000. Several steam hammers ranging up to five tons have been purchased.

Ohio Trailer Co., Cleveland, has purchased a site on Oakview avenue near Dille road, where it plans to erect a factory to manufacture automobile trailers.

Imperial Wagon Co. has been incorporated at Lynchburg, Va., capital \$300,000. President, J. A. Gumm, Atlanta, Ga.; secretary-treasurer, M. G. Houser, Lynchburg.

Heiss & Ganns, 518 East 133d street, New York, operating a wagon and wagon parts manufacturing plant, have filed plans for a one-story shop addition, 35 x 95 ft., to cost \$10,000.

The Samson Trailer Co. has purchased ten acres of land adjoining the property of the United Truck Co., at Grand

Rapids, Mich., and will erect a factory for the manufacture of trailers.

Ahlbrand Carriage Co. Seymour, Ind., has bought the entire stock of the Connersville (Ind.) Buggy Co., which includes their entire buggy business, as well as sewing machine wagon business, good will, etc.

Butte (Mont.) Carriage Works has purchased a large tract of land and will build a modern two-story factory to be used for the construction and manufacture of carriages, trucks, etc., and the remodeling of automobiles. The building will be constructed of fire-proof brick and cement.

Kautt Auto & Wagon Co. has been incorporated with an authorized capital stock of \$50,000, to engage in the manufacture of auto trucks, trailers, wagons, etc., in St. Paul. The officers are: Wm. Kautt, president; Jos. E. Pierce, vice-president, and Fred'k W. Zollman, secretary-treasurer.

## Decision Against Using Confidential Information for One's Personal Advantage

The DuPont Fabrikoid Co. has won another point in its legal fight to protect its rights to trade secrets involved in the manufacture of leather substitutes.

The United States Supreme Court, through an opinion of Associate Justice Holmes, has reversed the finding of the Third Circuit Court in the case of the DuPont Fabrikoid against Walter E. Masland, a former employe who, it was charged, sought to use in a business of his own, knowledge of the manufacture which he gained as a confidential employe of the DuPonts. The way is left open for further action in the District Court.

The case has been pending for some time and was decided in the first court for the company, which sought to enjoin Masland from making use of knowledge that he had confidentially acquired while in its employ. The Court of Appeals reversed the lower court.

In all its phases the case was full of interesting discussions as to the rights of parties to the action to reveal business secrets in the form of evidence before the court, and many of the hearings were in secret to prevent such revelation.

The case was finally taken to the highest tribunal, which now decides that the main point at issue is the company's right to be protected against a breach of confidence to all manufacturing industries, as it involves every business structure which is erected on the foundation of secret processes and trade secrets. In plain words it means that an employe of any concern who during his employment learns or acquires business secrets is restrained from making use of this knowledge for his own personal advantage after leaving said firm.

## Morgan Potter to Build Autos and Trucks

The Morgan Potter Mfg. Co., Beacon, N. Y., is changing its name to the Morgan Potter Motor Co., and will devote its plant to the manufacture of a four-cylinder five-passenger touring car, a light truck and truck converters. Morgan Potter, president of the company during its 30 years' experience as a carriage accessory maker, continues at the head of the business.

All products of the company will bear the name Beacon. The company expects to develop an extensive export trade with South Africa, Australia and South America.

### Russel Axle Company's Bonus Plan

The Russel Motor Axle Co., North Detroit, Mich., maker of internal gear drive axles for motor trucks, has placed its employes on a bonus basis of pay and each worker will net an additional 10 per cent of his normal monthly pay if he qualifies under the conditions of the plan.

A. W. Russel, president of the company, in announcing the plan, says that it was adopted to provide an incentive to employes for steady and continuous work, which will make possible maintenance of production at the maximum point which has become necessary owing to the great increase in business.

Starting February 1, 1917, 10 per cent of the monthly wages of each employe will be credited to him, payment of this bonus to be made every three months, beginning August 1, 1917. Payment of bonus is subject to the approval of the department foreman under whom the employe is working. Employes who show proof of enlistment in the army or navy or marine corps will be entitled to their bonus up to the time of their leaving the employ of the Russel company. In case it should be necessary to lay off employes because of lack of work, the full bonus up to the time of discharge will be paid, provided the employe has worked steadily for the best interests of the company.

A. C. Bagley, credit manager for the Hess-Bright Mfg. Co., Philadelphia, Pa., has been appointed manager of the credit department of the Motor and Accessory Manufacturers, New York, and already has assumed charge of the work of expanding the activities of the department.

### Final Michigan Buggy Dividend

Creditors of the Michigan Buggy Co., of Kalamazoo, which became bankrupt three years ago, on June 7 received the sixth and final dividend that had been declared from the assets of the bankrupt estate. This dividend totals 23 per cent of the indebtedness of the concern, and was three per cent more than was estimated by the creditors when the trustee first took over the assets.

## WANTS

Help and situation wanted advertisements, 1 cent a word; all other advertisements in this department, 5 cents a word; initials and figures count as words. Minimum price, 30 cents for each advertisement.

**Wanted**—Copies of The Hub of May and July, 1916. Must be in good condition. Address Trade News Publishing Co., corner Elm and Duane streets, N. Y. City.

### PATENTS

**Patents**—H. W. T. Jenner, patent attorney and mechanical expert, 606 F St., Washington, D. C. Established 1883. I make a free examination and report if a patent can be had and exactly what it will cost. Send for circular.

### FOR SALE

**For Sale**—"Motor Body Work for Commercial Cars," a new text book dealing with the construction of all types of bodies for business purposes. Contains also six working drawings and a glossary of technical terms, together with diagrams and sketches. Price, \$1.20 net; by post, \$1.56. Orders should be accompanied by remittance. Cooper's Vehicle Journal, Ltd., 19 Garrick street, Long Acre, London, England.

## Sheet Metal Stampings and Specialties

Send us your inquiries and specifications for Sheet Metal Stampings of any kind. Our experience covers 40 years in this class of work in all kinds of metals.

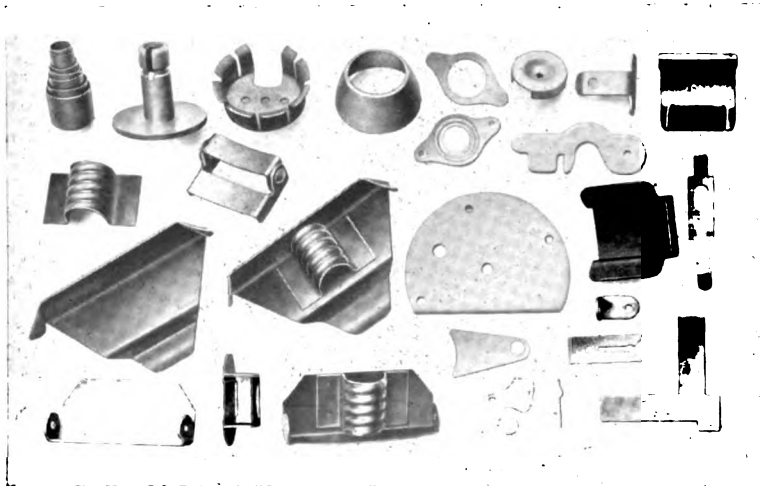

Our equipment includes not only presses but electric welding machines, japanning ovens, etc., enabling us to finish complete any parts, ready for immediate use, saving you this additional cost.

Our capacity for this class of work enables us to produce several hundred thousand pieces per day.

Special attention is given rush orders.

Catalog sent on application.

## Peter Gray & Sons, Inc., Cambridge, Mass.





FABRICS  
**BRIDGEPORT**  
FABRICS

**“FINE FEATHERS MAKE FINE BIRDS”**

This saying can be applied to the modern motor car. **QUALITY** furnishings and interior decorations play a strong part in **selling** a car and **keeping** it sold.

Cheapness and Quality can never mix; but there is a happy medium wherein quality **can be secured** at a **reasonable** price.

FABRICS  
**BRIDGEPORT**  
FABRICS

Leaders in their class for over Three-Quarters of a Century, have imparted that air of elegance and refinement to the highest grade Coaches, Carriages and Automobiles.

No scheme of interior decoration is so complex but what a Bridgeport Fabric will be found to fit in to perfection.

Our designers are prolific in new ideas in colorings and textures that give individuality to the cars on which they are used.

Bridgeport Fabrics are woven on our own looms by the highest grade of skilled workmen who, from generation to generation, have maintained the high standard of excellence always associated with these goods.

Critical inspection amply safeguard that Super-Quality which has been our key-note for 80 long years.

The car interiorally furnished in Bridgeport Fabrics bespeaks luxury and elegance—it is an easy seller.

Let us send samples showing Super-Quality at Reasonable Cost.

**BRIDGEPORT COACH LACE CO.**

Established 1837

**BRIDGEPORT, CONN.**

**NEW YORK, 1733 Broadway**

Acme  
Die-Cast  
Uniform  
Smooth  
and Fine Finish

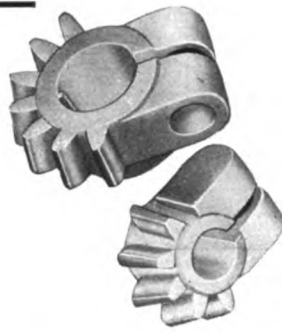

Accuracy Guaranteed

The Acme die-casting process is practically automatic. High pressure, scientific heat regulation of dies and metal, and long experience enable us to turn out large quantities of quality die-castings in aluminum and white metal alloys. We guarantee them to be accurate and strictly in accordance with specifications.

We will gladly send samples and submit quotation on receipt of models or prints.

Aluminum or White Metal Alloys

Acme Die-Casting Corporation  
Dush Terminal Bldg. No. 5, 37th St. and 3d Ave.  
Brooklyn, N. Y.

Boston—  
176 Federal St.  
Philadelphia—  
Widener Bldg.

TRADE MARK

Detroit—  
965 Woodward Ave.  
Chicago—  
549 Wash. Blvd.

CANADIAN DISTRIBUTORS:  
Lyman Tube & Supply Co., Ltd., Montreal



Meet me at the Tuller for Value, Service, Home Comforts

NEW  
**HOTEL TULLER**  
Detroit, Michigan

Center of business on Grand Circus Park. Take Woodward car, get off at Adams Avenue.

ABSOLUTELY FIREPROOF

200 Rooms, Private Bath, \$1.50 Single, \$3.00 Up Double
200 " " " 2.00 " 4.00 " "
100 " " " 2.50 " 4.50 " "
100 " " " 3.50 to 5.00 " 5.00 " "

Total, 600 Outside Rooms

ALL ABSOLUTELY QUIET

Two Floors—Agents' Sample Rooms

New Unique Cafes and Cabaret Exellente

Index To Advertisers

Acme Die-Casting Corporation.....	34
American Motors Corporation.....	4
Barrell Co., Wm. L.....	38
Bay State Pump Co.....	35
Bela Body Co., The.....	39
Bliss, E. W., Co.....	3
Bookwalter Wheel Co.....	40
Bradley, C. C., & Son.....	41
Brennan Motor Mfg. Co.....	43
Bridgeport Coach Lace Co.....	33
Columbus Bolt Works.....	Back cover
Cowles, C., & Co.....	40
Crane & MacMahon, Inc.....	Back cover
Decker, J. C.....	40
Dowler, Chas. L.....	40
DuPont Fabrikoid Co.....	38
Eccles, Richard, Co.....	42
Empire Art Metal Co., Inc., The.....	36
G & O Mfg. Co.....	43
Gray, Peter, & Sons, Inc.....	32
Hartford Auto Parts Co.....	3
Hoopes Bro. & Darlington.....	43
Hotel Brunswick.....	41
Hotel Tuller.....	34
Jenner, H. W. T.....	32
Johnston, R. F., Paint Co.....	40
Keratol Co., The.....	38
Laidlaw Co., The.....	2
Lumen Bearing Co.....	37
Millersburg Fifth Wheel Co.....	40
Mulholland Co., The.....	40
Murcott-Duden Co., The.....	2
Norton Grinding Co.....	5
Parrott Varnish Co., The.....	2
Pettingell Machine Co.....	7
Pierce Co., F. O.....	37
Porter, H. K.....	41
Pressed Steel Co.....	2
Quickwork Co., The.....	41
Rhodes Mfg. Co., The.....	41
Rome-Turney Radiator Co.....	42
Russell, Burdsall & Ward Bolt & Nut Co.....	41
Sheldon Axle & Spring Co.....	8
Standard Oil Cloth Co., Inc.....	6
West Tire Setter Co.....	36
White-Quehl Mfg. Co.....	40
Wilcox Mfg. Co., D.....	36
Willey Co., C. A.....	42
Williams, J. H., & Co.....	Front cover
Wing, Chas., Co.....	40
Yoder Company, The.....	Back cover

Please mention "The Hub" when you write

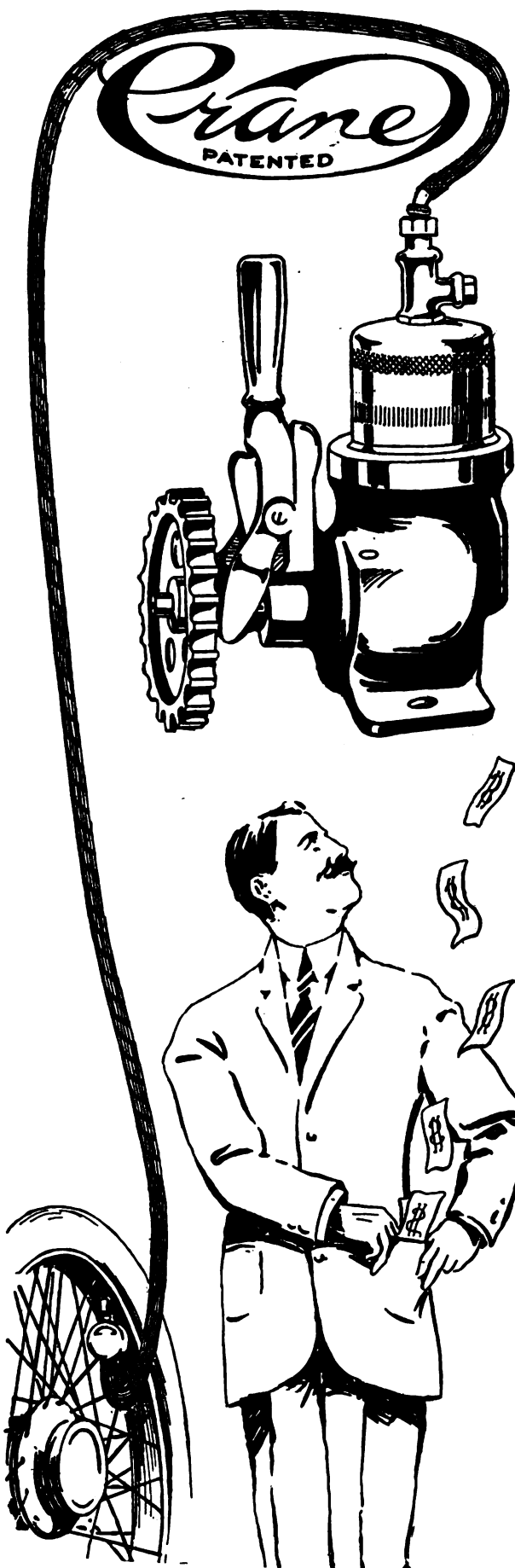

# 50 per cent More Efficient In Putting Air Into Tires and Profits Into Pockets

CRANE is the swiftest-selling tire-pump. Because it's 50% more efficient. And costs 50% less.

It delivers 50% more air than any other same-size pump. Because of its patented packing ring.

It puts more mileage into tires--by keeping oil out of the tubes.

It lasts longer and runs smoother—because every moving part is bathed in oil.

It adds less weight and requires less power—because it's **HALF** the size and has **ONE-FOURTH** the parts.

High efficiency is the result of simplicity. And simplicity means lower cost.

That's why you can sell more CRANES at \$10 COMPLETE—than other pumps costing twice the price.

Price includes Hose, Pressure-Gauge and Special Fittings for nearly every make and model car.

No holes to drill; no studs to drive. Attached in a jiffy. And sells on sight.

ORDER FROM YOUR JOBBER  
OR WRITE US

**BAY STATE PUMP COMPANY**  
100 Purchase Street                      Boston, Mass.

Please mention "The Hub" when you write

**We Are Prepared to Render Rapid Service on**

# **Steel Sash Frames**

# **Mouldings**

# **Tubing**

# **Special Shapes**

**Made to Your Blueprint**

**THE EMPIRE ART METAL CO., Inc.**

**COLLEGE POINT, N. Y.**

## **Vehicle Mechanics**

Desiring to improve their present  
Condition should attend the

## **TECHNICAL SCHOOL**

For

## **Automobile Draftsmen and Mechanics**

Supported by the

The National Automobile Chamber of Commerce, Inc.

The object of the School is to teach men to design vehicles and make working drawings, and to otherwise facilitate their work in the shop. Only those men employed in carriage or automobile building or their accessory trades are admitted to its privileges.

The classes are conducted in three divisions, viz.: Corresponding, Day, and Evening. The former is open during the entire year, while the day and evening classes are in session only from October 1 to April 1.

The tuition is moderate.

For prospectus and full particulars, write to the instructor,

**ANDREW F. JOHNSON,**  
20 West Forty-fourth St.,  
NEW YORK CITY

## **The WEST Hydraulic Tire Setter**

**WILL CUT DOWN EXPENSE**



Tires set cold in one minute. This machine saves time—does the work better and quicker, does a way with burned streaks. Only necessary to measure one wheel in a lot. Does not char the rim, and thus make the tire loosen prematurely. Saves resandpapering of wheels. This machine is now increasing the profits of many manufacturers. Send for catalog and read about it.

**WEST TIRE SETTER CO., ROCHESTER, NEW YORK**

## **WILCOX**

**FINE  
FINISHED  
FORGED**

**CARRIAGE HARDWARE  
AND GEAR IRONS**

Write for Prices and Catalog

**The D. Wilcox Mfg. Co.**  
MECHANICSBURG, PA.

# F. O. PIERCE COMPANY

## NEW YORK, U. S. A.

Manufacturers of High Class Pigment Colors

### FOR AUTOMOBILE PAINTING

Made from ORIGINAL FORMULAE.  
Colors ground in Japan and other MEDIUMS  
to meet any SYSTEM of APPLICATION

We can now supply Uzatona in Japan, Oil or Varnish. Prices upon application

# MACHINEBRONZE

THE UNIVERSAL  
BEARING BRONZE

Are Your Machines  
*Making* Money, or  
*Costing* Money?

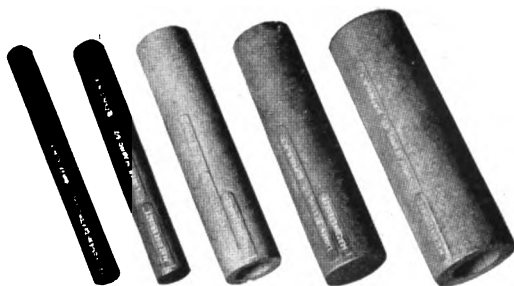

Carried in stock in solid and cored bars of 12" lengths—  
1/2" to 4 1/4" diameter, inclusive, by 1/8ths

Are your machines running steadily and MAKING money, or are they continually "down" for repairs and thus COSTING money?

If they are "down," worn bearings is probably the cause, as is the case nine out of ten times.

If you put cheap bearings in those machines that are "down," you'll no doubt have them "down" again in a short while.

It always pays to build them up with the best bearings you can buy. Bearings made of Machinebronze will cost you a little more, but consider the future shutdowns and overhauls they will save you.

You will be interested in our booklets.  
Send for them today

## LUMEN BEARING COMPANY

BRASS FOUNDERS  
BUFFALO

# Keratol LEATHER SKINS

For the car where leather has always been used



PRICE

*Within Reason*

QUALITY

*Maintained*

W<sup>m</sup> L. BARRELL Co. 8 THOMAS ST.  
NEW YORK

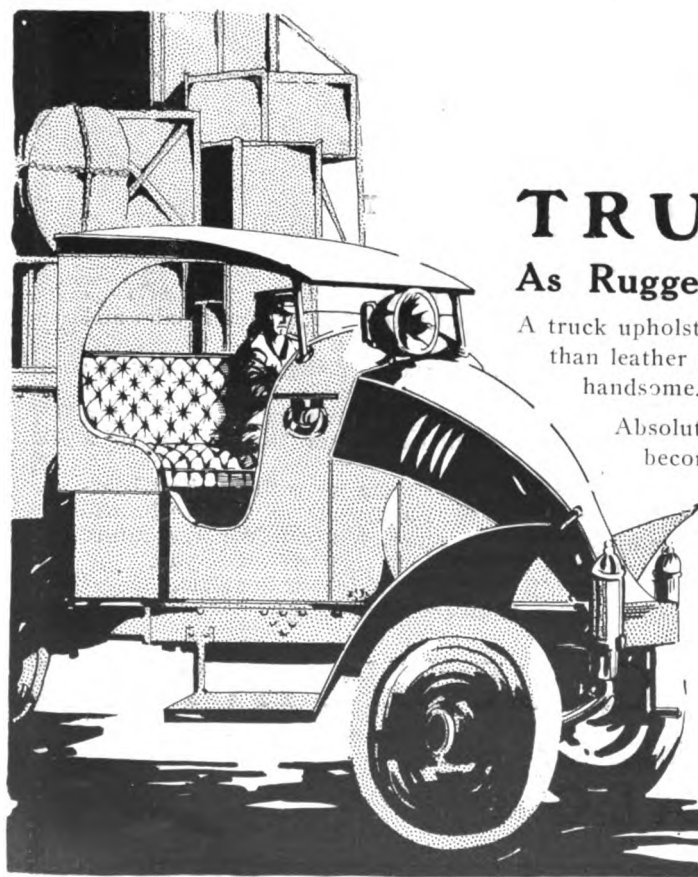

**DUPONT  
FABRIKOID**

REG. U. S. PAT. OFF.

## TRUCK SPECIAL

As Rugged As the Service It Is Made For

A truck upholstery material that is built for business—far better suited than leather to extreme conditions of work and weather and just as handsome.

Absolutely waterproof, grease proof and washable—cannot become unsanitary.

Comes in 60 yard rolls, 50 inches wide, uniform in strength and thickness.

Cuts in multiples without waste.

TRUCK SPECIAL FABRIKOID makes for comfort, cleanliness and economy.

*You should use it to save money*

*You should use it to save leather*

Write for Truck Special booklet, samples and prices.

**DuPont Fabrikoid Co.**  
Wilmington, Delaware



# DISTINCTIVE BODIES

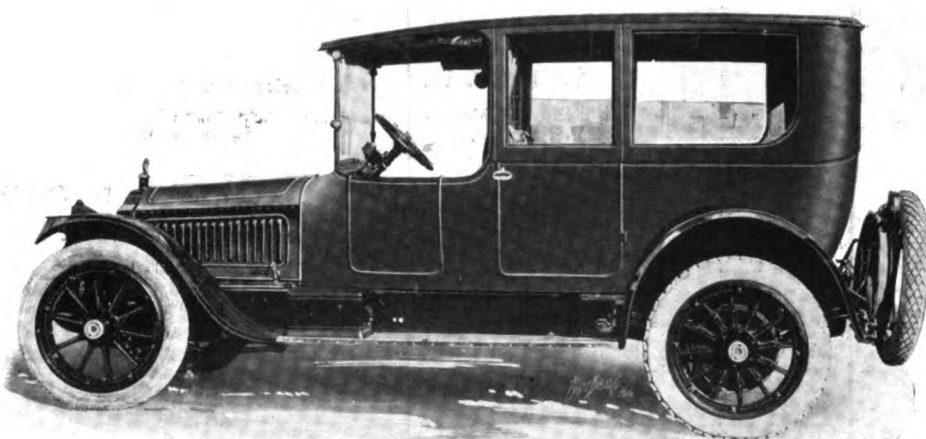

For Landaulets  
Limousines  
Sedans  
Coupes  
Roadsters  
Touring Cars

Limousine body on Packard chassis. Note the pleasing effect of the special streamline cover.

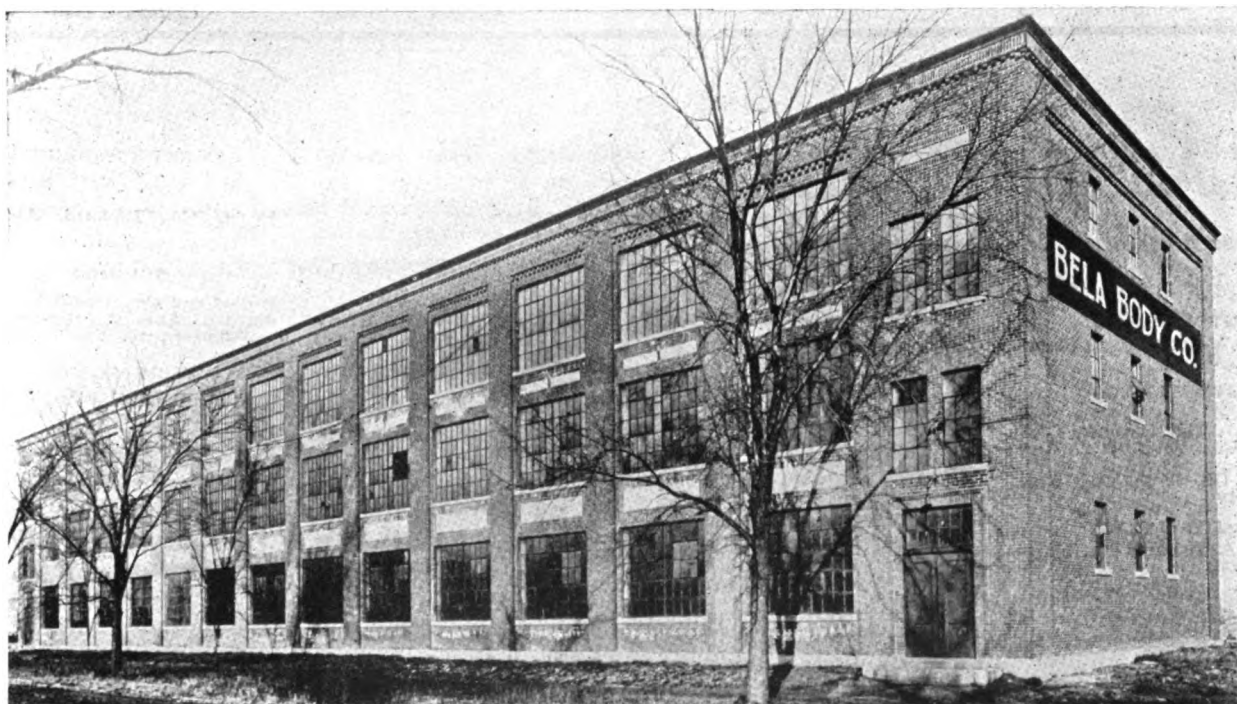

The Home of Bela Bodies

The above is one view of our Framingham Factory which is used for the painting, trimming and assembling of our bodies.

Our new 200 x 150 ft. building is under construction now, and will be ready for use in the very near future. In this new shop our bodies will be built in the white. Both buildings will be equipped with the most modern machinery and every facility for turning out the highest grade of work will be used.

We shall have our own spur track connecting with the N. Y. N. H. & H. R. R. and the B. & A. R. R., where we will load our bodies direct. Our shipping facilities are the very best.

**BELA BODY COMPANY**  
FRAMINGHAM, MASS. AMESBURY, MASS.

Please mention "The Hub" when you write

## BUSY BUYERS BRIEFS



Manufacturers  
**FIFTH  
WHEELS**  
All Varieties  
Heavy Goods a  
Specialty  
Iron and Steel Rings from 4 to  
60 inches wide  
**MILLERSBURG FIFTH WHEEL CO.**  
Millersburg, Pa.

WE MANUFACTURE  
**FINE VEHICLE  
WHEELS**  
The Bookwalter Wheel Co.  
MIAMISBURG, OHIO

**JOHNSTON'S  
KRAKNO**  
Color Card Free  
**\$3.50 per gallon**  
The R. F. Johnston Paint Co.  
Cincinnati, Ohio

### Why Not Have the Best?

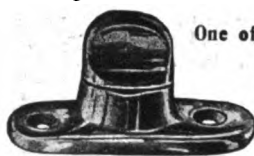

One of a Large Variety

**G. Cowles & Co.**  
NEW HAVEN,  
CONN.

### J. C. DECKER

MONTGOMERY, PA.

Manufacturer of

### Carriage, Skate and Pad Straps

Side Loops, Bridle Fronts, Tail Ties, etc.

### THE CHARLES WING CO

Established 1848

Manufacturers and Wholesale Dealers in

### AUTOMOBILE AND CARRIAGE HARDWARE AND TRIMMINGS

AMESBURY, MASS., U. S. A.

### CHARLES L. DOWLER

CARRIAGE AND WAGON HARDWARE

108 North Third St., Philadelphia, Pa.

### CUSHION MANUFACTURER

Pure Stearic Acid Candles. Wheel Stock. Snow  
Flake Axle Grease.

### MULHOLLAND BUGGY SPRING

Reduces weight of springs one-half.  
Made in one size only but will fit bodies  
of all widths.

Write for further particulars and prices.  
**THE MULHOLLAND CO. DUNKIRK, N. Y.**

### White's Brazing Sleeves

For applying Rubber Tires  
Send for Samples.

### WHITE-QUEHL MFG. CO.

431 E. Pearl St.  
CINCINNATI, OHIO

## CLASSIFIED INDEX

For Addresses See Alphabetical Index  
and Advertising Pages

### AUTOMOBILES

American Motors Corp., Plain-  
field, N. J.

### AUTO FABRICS

Farrell, Wm. L., Co., New York  
Keratol Co., The, Newark, N. J.  
Laidlaw Co., Inc., The, New  
York  
Standard Oil Cloth Co., New  
York City.

### AUTO PARTS

Hartford Auto Parts Co., Hart-  
ford, Conn.

### AXLES (Including Ball and Roller Bearing)

Sheldon Axle & Spring Co.,  
Wilkes-Barre, Pa.

### BODIES

Bela Body Co., Framingham,  
Mass.

### BOLTS AND NUTS

Columbus (O.) Bolt Works Co.  
Russell, Burdall & Ward Bolt  
& Nut Co., Port Chester, N.Y.

### BOLT CLIPPERS

Porter, H. K., Everett, Mass.

### BRAZING SLEEVES

White-Quehl Mfg. Co., Cincin-  
nati, O.

### BRONZE BEARINGS

Lumen Bearing Co., Buffalo.

### DIE CASTINGS

Acme Die Casting Corp., Brook-  
lyn, N. Y.

### DIES

Bliss Co., E. W., Brooklyn, N.Y.  
(Sheet Metal Working).

### FORGINGS

Eccles, Richard, Auburn, N. Y.  
(Carriage, Drop).  
Williams, J. H., & Co. Brook-  
lyn, N.Y. (Automobile, Drop)

### FIFTH WHEELS

Millersburg Fifth Wheel Co.,  
The, Millersburg, Pa.  
Wilcox Mfg. Co., D., Mechanics-  
burg, Pa.

### HARDWARE (Carriage, Wagon and Automobile)

Columbus (O.) Bolt Works Co.  
Dowler, Chas. L., Philadelphia.  
Eccles Co., Richard, Auburn,  
N. Y.  
Wilcox Mfg. Co., D., Mechan-  
icsburg, Pa.  
Wing Co., Chas., Amesbury,  
Mass.  
Cowles, C., & Co., New Haven,  
Conn.

### LEATHER SUBSTITUTES

Barrell Co., Wm. L., New York.  
Keratol Co., The, Newark, N. J.  
Standard Oil Cloth Co., New  
York.  
DuPont Fabrikoid Co., Wil-  
mington, Del.

### MACHINERY AND TOOLS

Bliss Co., E. W., Brooklyn, N.Y.  
Norton Grinding Co., Worces-  
ter, Mass.  
Pettingell Machine Co., Ames-  
bury, Mass.  
Rhodes Mfg. Co., The, Hart-  
ford, Conn.  
Smith, H. Collier, Detroit, Mich.  
West Tire Setter Co., Roches-  
ter, N. Y.  
Williams, J. H., & Co., Brook-  
lyn, N. Y.  
White-Quehl Mfg. Co., Cincin-  
nati, O.  
Yoder Co., The, Cleveland, O.

### MACHINERY (Metal Working)

Bliss Co., E. W., Brooklyn, N.Y.  
Pettingell Machine Co., Ames-  
bury, Mass.  
Quickwork Company, Detroit,  
Mich.  
Yoder Co., The, Cleveland, O.

### METAL STAMPINGS AND NOVELTIES

Gray, Peter, & Sons, Inc., Cam-  
bridge, Mass.  
Murcott-Duden Co., Inc., New  
York.  
Pressed Steel Co. of New York,  
New York City.

### MOTORS

Brennan Motor Mfg. Co. Syra-  
cuse, N. Y.

### PATENTS

Jenner, H. W. T., Washington,  
D. C.

### PAINTS AND COLORS

Johnston Paint Co., R. F., Cin-  
cinnati, O.  
Pierce Co., F. O., New York.  
Sherwin-Williams Co., Cleve-  
land, O.  
Willey Co., C. A., Hunter's  
Point, N. Y.

### PRESSES

Bliss Co., E. W., Brooklyn, N.Y.  
(Drop, Power).

### RADIATORS

G. & O. Mfg. Co., New Haven,  
Conn.  
Rome-Turney Co., Rome, N. Y.

### SCHOOL FOR DRAUGHTS- MEN

Mechanics' Institute, New York

### SHAFT COUPLINGS

Bradley & Son, C. C., Syracuse,  
N. Y.  
Eccles Co., Richard, Auburn,  
N. Y.

### SPRINGS

Mulholland Co., Dunkirk, N. Y.  
Sheldon Axle & Spring Co.,  
Wilkes-Barre, Pa.

### TIRE PUMPS

Ray State Pump Co., Boston,  
Mass.

### TOOLS

Williams, J. H., & Co. Brook-  
lyn, N. Y.

### TRIMMING MATERIAL

Bridgeport (Conn.) Coach Lace  
Co.  
Decker, J. C., Montgomery, Pa.  
Wing Co., Chas., Amesbury,  
Mass.

### UNIVERSAL JOINTS

Hartford (Conn.) Auto Parts  
Co.

### VARNISH AND JAPAN

Parratt Varnish Co., Bridgeport,  
Conn.  
Pierce Co., F. O., New York.  
Sherwin-Williams Co., Cleve-  
land, O.  
Willey Co., C. A., Hunter's  
Point, N. Y.

### WHEELS

Bookwalter Wheel Co., Miamis-  
burg, O.  
Crane & MacMahon, Inc., New  
York City.  
Hoopes Bros. & Darlington,  
Inc., West Chester, Pa.

### WOOD BENDINGS, WHEEL STOCK, ETC.

Crane & MacMahon, Inc., New  
York City.

Please mention "The Hub" when you write



**TEMPERED STEEL RING**

**LEATHER PACKING**

The Only One-piece Moulded Leather Packing

## The Bradley Carriage Coupler

All-Steel    Noiseless    Quick-Shifting    Ball-Bearing

(MADE IN FIVE SIZES FOR AXLES ¼ INCH TO 2¼ INCH)

The only carriage coupler that is furnished with a ONE-PIECE MOULDED LEATHER PACKING

**C. C. BRADLEY & SON, Syracuse, N. Y.**



**SHAY**  
**LEATHER PACKING**

**AXLE**

The Bradley Carriage Coupler

## THE BRUNSWICK



**Boylston Street, Corner Clarendon,**  
(Facing Copley Square)

**BOSTON - - MASS.**

High class modern house, intelligent service, pleasant rooms, superior cuisine. Ladies traveling alone are assured courteous attention

European plan, single rooms, \$1.50 up; with bath, \$2 up; double, \$2 up; with bath, \$3 up.  
American plan, \$4 per day up.

**FRED E. JONES - Proprietor**

## RHODES

### 7 in. Crank Shaper



Designed and constructed for light and thoroughly accurate work, this small shaper has all the essential features of the large, high-priced machines. We build them horizontal, vertical, and a combination of the two. They are light running and easy to handle, and for economical work on dies, tools, models, etc., their equal does not exist today. Let us send you full description of these modern, improved machines.

**Rhodes Manufacturing Co.**  
**Hartford, Conn.**

**“Quickwork”**      Sheet Metal Working Machinery

For Automobile and Carriage Bodies, Fenders, Hoods, etc.

**THE QUICKWORK CO.**

H. COLLIER SMITH, Pres. and Gen. Mgr. ST. MARYS, O.

**PORTER'S BOLT CLIPPERS**  
“Easy” “New Easy” Allen-Roadall



To Cut 5-16, 3-8, 1-2, 5-8, 3-4 Inch.

**H. K. PORTER,**  
**EVERETT, MASS.**

## RUSSELL, BURDSALL & WARD BOLT & NUT CO.

Established 1845      PORT CHESTER, N. Y.

**MAKERS OF THE CELEBRATED EMPIRE BOLTS AND NUTS**

Western Office: Continental & Commercial Bank Bldg., Chicago, Ill. Branch Works: Rock Falls, Ill.

Please mention “The Hub” when you write

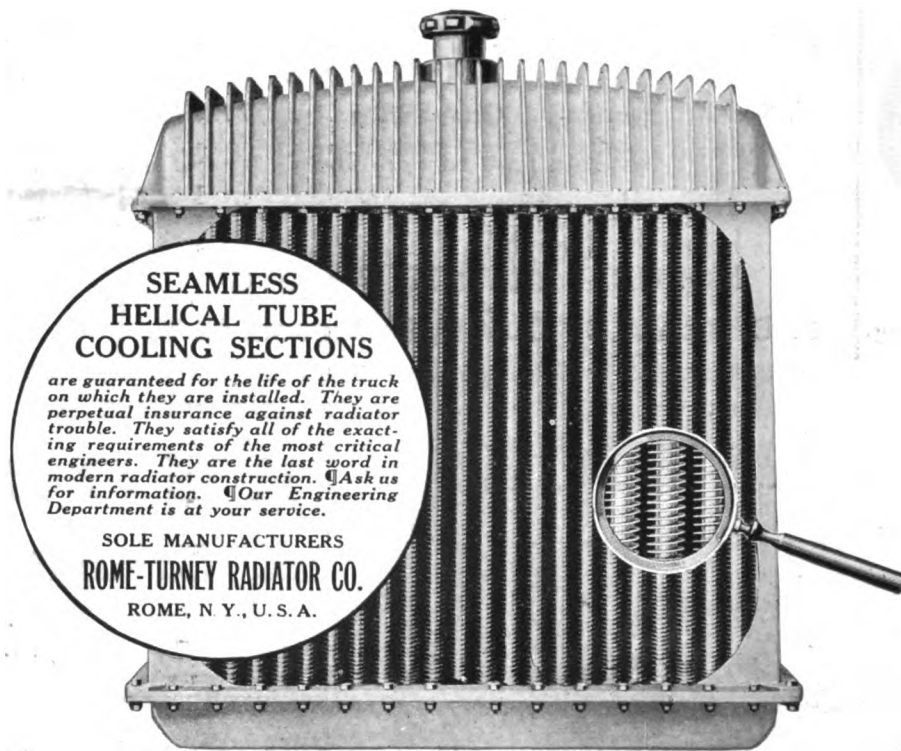

# WILLEY'S COLORS

The Recognized Standard



**C. A. WILLEY CO.**  
COLOR GRINDERS

and Manufacturers of Specialties in

**CARRIAGE, AUTOMOBILE and CAR**

**PAINTS**

**COLORS, VARNISHES, ETC.**

**HUNTER'S POINT, NEW YORK CITY**

## High Grade Forgings

for CARRIAGE, WAGON, AUTO-MOBILE and SPECIAL WORK

ECCLES BALL-BEARING COUPLINGS are the BEST on the MARKET for DURABILITY and EASE OF ADJUSTMENT

LEATHER BUSHINGS ARE FAST-ENED IN THE SOCKET WHERE THEY BELONG



SPECIAL FEATURE—THE SPRING IS PIVOTED AT THE FRONT TO ALLOW EASY ADJUSTMENT

Please bear in mind that we make a FULL LINE of Carriage and Wagon Forgings, also many of those for Auto and Special Work.

Send for our new Catalogs showing our Regular and Special Forgings.

QUALITY GUARANTEED.

SERVICE—THE BEST

**Richard Eccles Co.**  
AUBURN, NEW YORK



# HOOPES BRO. & DARLINGTON

(INCORPORATED)

WEST CHESTER, PA.

WE ARE MAKING

# AUTOMOBILE WHEELS

Forty Years' Experience as WHEEL MAKERS is guarantee we can make good ones.  
Will not make any other kind. Try them.



ENGINE COOLING

## RADIATORS

FOR PLEASURE CAR AND HEAVY DUTY SERVICE

G & O MFG. CO. - New Haven, Conn.

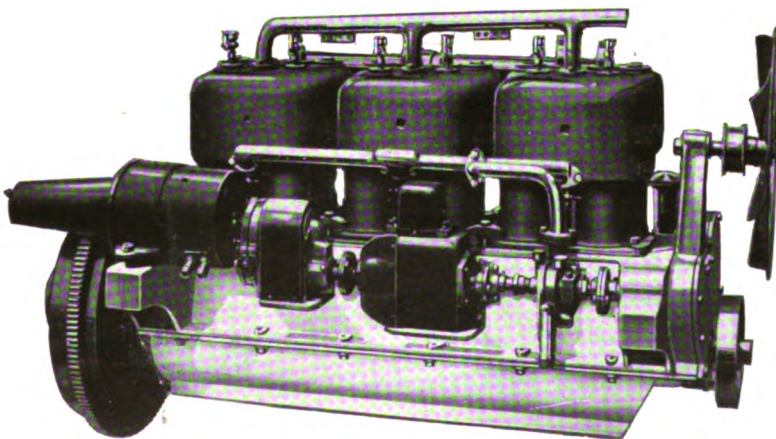

Model 6B Motor, 4½" bore by 5" stroke

## Quality and Service

are the two essentials that for 17 years have been built into

# BRENNAN STANDARD MOTORS

The manufacturer of Commercial or Pleasure cars who equips his product with Brennan Standard Motors can feel assured his every requirement regarding this vital part has been fulfilled.

Built in the following sizes:

4 Cylinder Model M-4 x 5	4 Cylinder Model 12-5½ x 6
4 Cylinder Model B-4½ x 5	4 Cylinder Model 12-6 x 6
4 Cylinder Model 11-5 x 5	6 Cylinder Model 6B-4½ x 5

Let us send bulletins telling WHY Brennan Motors are STANDARD motors

**Brennan Motor Mfg. Co., Syracuse, N. Y.**

Please mention "The Hub" when you write

# AUTOTRUCK

Hickory Nut and

BEST QUALITY STOCK  
TOUGH AND HEAVY  
BONE DRY

MANUFACTURED BY  
CAPABLE MECHANICS  
AND MOST  
IMPROVED MACHINERY

WHEELS WHICH ADD TO  
THE LIFE OF YOUR TRUCK

ST. MARYS, OHIO

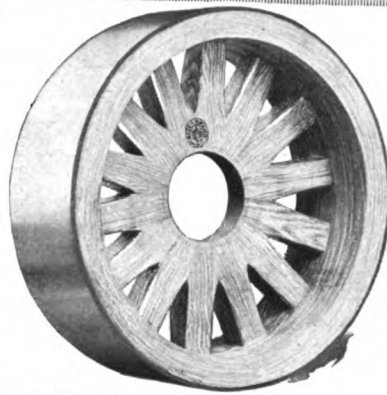

# WHEELS

Acorn Brands

HORSE-DRAWN  
VEHICLE WHEELS  
ALL STYLES

TRAILER WHEELS:  
SARVEN AND  
ARTILLERY TYPES

HIGH STANDARD OF  
QUALITY AND  
WORKMANSHIP  
MAINTAINED

CRANE & MacMAHON, Inc.

8 BRIDGE ST., N. Y. CITY

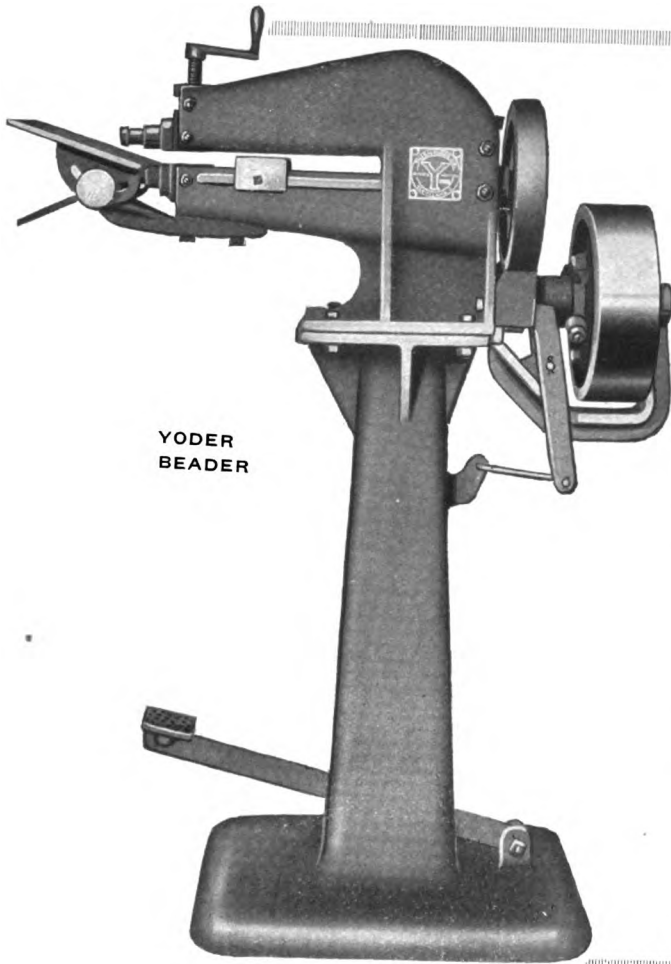

YODER  
BEADER

## Yoder Sheet Metal Machinery

Our line of Auto Sheet Metal Working Machinery is efficient in every detail.

Every machine is constructed with the objective of producing perfect results at a minimum cost of material and labor.

The Yoder Company guarantees its machinery to produce results satisfactory to the purchaser.

We are glad to consider your Sheet Metal Machinery needs, as well as your requirements for special machines.

If you are thinking of making your own sheet metal parts or producing sheet metal products for the trade, get in touch with us at once. We can save you money and furnish a most satisfactory and complete equipment.

Catalog and prices furnished on request

### The Yoder Company

Engineers Building

CLEVELAND - - OHIO

## Skewed Shaft Couplings

Regular or Oval Patterns  
For High Arched Axles

Furnished in rights and lefts for any height of arch.  
Oval Axle Clips  $\frac{5}{8}$  or  $\frac{3}{4}$  width to match Oval  
Couplings. Bolts, Clips, Couplings, Carriage  
Hardware and Special Forgings

Catalogue "H" and Prices on Application

COLUMBUS BOLT WORKS COMPANY

COLUMBUS, OHIO

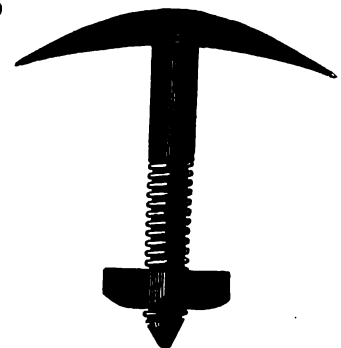
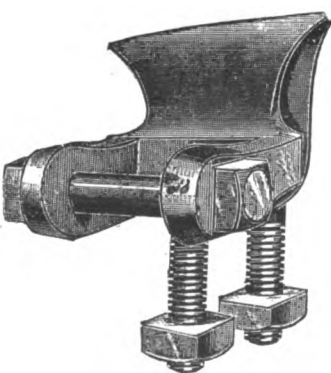



# The Hub

First Journal of the Vehicle Industry

Vol. LIX

NEW YORK, JULY, 1917

No. 4

## SHELDON WORM GEAR AXLES

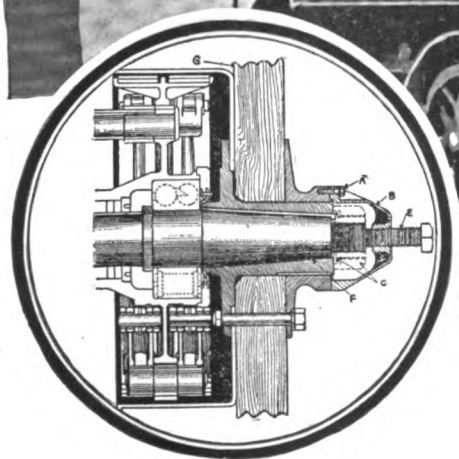

Ready demountability of Sheldon Wheel. Remove parts A, B, C, D. Replace hubcap B. Insert setscrew E. Jam screw against drive shaft. Tap back of wheel at G till it comes loose

Used by the Fifth Avenue Coach Company to Reduce Maintenance Costs

THE ESPECIALLY RIGOROUS SERVICE CONDITIONS to which the Fifth Avenue Buses are subjected make necessary frequent inspection, replacement and repair of wheels. THE ECONOMIC MANAGEMENT OF THESE BUSES therefore dictates that they be equipped with rear axles of a construction permitting the wheels to be quickly and directly removed, and replaced with minimum trouble and without the use of expensive skilled labor.

THE SIMPLICITY OF THE SHELDON semi-floating type of axle construction makes this removal and replacement simple and economical—saving costs in labor and in depreciation due to too frequent mechanical handling of working parts and the exposing of ball bearings to grit.

THIS IS ONE OF MANY WAYS in which the Fifth Avenue Coach Company have reduced maintenance costs through the

adoption of worm-driven SHELDON ax'es. THIS COMPANY WITH UNEQUALLED OPPORTUNITIES FOR SUCH INVESTIGATION has discovered that Sheldon Worm Gear Axles insure them the lowest cost-per-mile haulage.

AS A PROSPECTIVE TRUCK BUYER WHY not be guided by their experience? WRITE FOR MORE COMPLETE INFORMATION.

**SHELDON AXLE & SPRING COMPANY**

Makers of Springs and Axles for Heavy Duty Service for over 50 years

Wilkes-Barre

Pennsylvania



# PARROTT VARNISHES



.. Unequaled for ..

**Automobile  
and  
Carriage  
Finishing**

**The Parrott Varnish Co.**  
Bridgeport, Conn.



## SEAMLESS TUBING STEEL—BRASS—COPPER

Send Us Your Specifications  
for Rush Requirements

**MURCOTT-DUDEN CO., Inc.**  
253 Broadway New York



# steel stampings

*especially for*  
**COMMERCIAL TRUCKS**

**The Pressed Steel Company**  
Wilkes-Barre, Pa.

## The Laidlaw Company Inc.

New York City

.....

**Automobile  
Fabrics**

.....

**A Fabric for  
Every Purpose  
For Closed, Open or  
Convertible Bodies**

# There is a size that will successfully meet your exact requirements

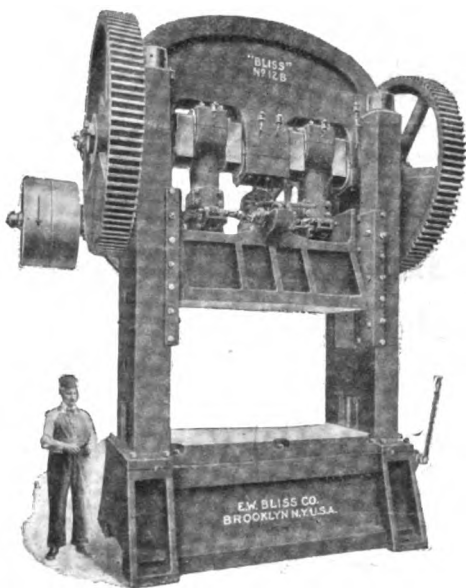

Presses with correct proportions for use in the manufacture of large sheet iron and steel goods. The large diameter shafts and well-gibbed sides allow quantity production that's profitable.

## Bliss Double-Crank Presses

Adapted for the economical production of vapor stoves, wrought iron ranges, agricultural implements, automobile stampings, steel car parts, ceilings, sidings, metal doors, window frames and sashes, metal furniture and similar goods.

Built in over 150 sizes, there is one adapted to your special requirements. Write today for descriptive matter.

*Talk to us about presses for any and every requirement*

## E. W. BLISS CO

38 Adams St., Brooklyn, N. Y.

Chicago Office: Peoples Gas Building.

Detroit Office: Dime Bank Building.

Cleveland Office: Union Bank Building.

Offices in Europe: 100 Boulevard Victor-Hugo, St. Ouen, Paris; Pockock St., Blackfriars Road, London, S.E.



# Hartford

## Maximum Bearing Surface for Every Given Size

All unnecessary parts have been eliminated from Hartford UNIVERSAL DRIVES AND CONE CLUTCHES. They are light, yet exceedingly strong—simple in design—bearings are self-oiling.

They are high in quality, too—.40 carbon cold drawn seamless steel tubes being used for all shafts. The high carbon steel is made to special order by Carnegie Steel Co. and is always first analysed before being used.

Hartford UNIVERSAL DRIVES AND CONE CLUTCHES are used by some of the largest automobile manufacturers in this country. You, too, can use them to great advantage. INVESTIGATE!

## Hartford Auto Parts Co.

Hartford, Conn.

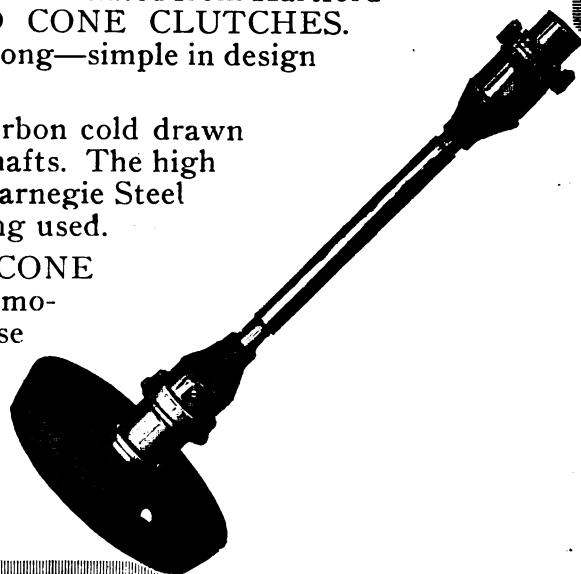
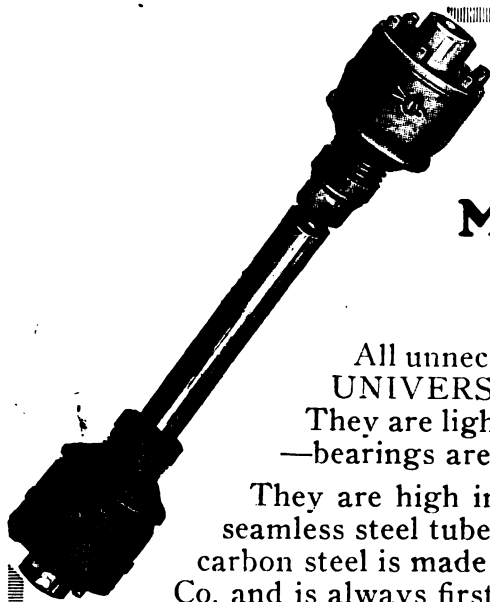

# LOOK INTO IT

---

**The Sales agency for the AMERICAN SIX represents an unusual money-making opportunity for readers of The Hub.**

**Get the whole proposition from the factory, Plainfield, N. J.**

**The car is six-cylindereed, of beautiful design, big, roomy and mechanically right.**

45 horsepower  
122 in. wheelbase

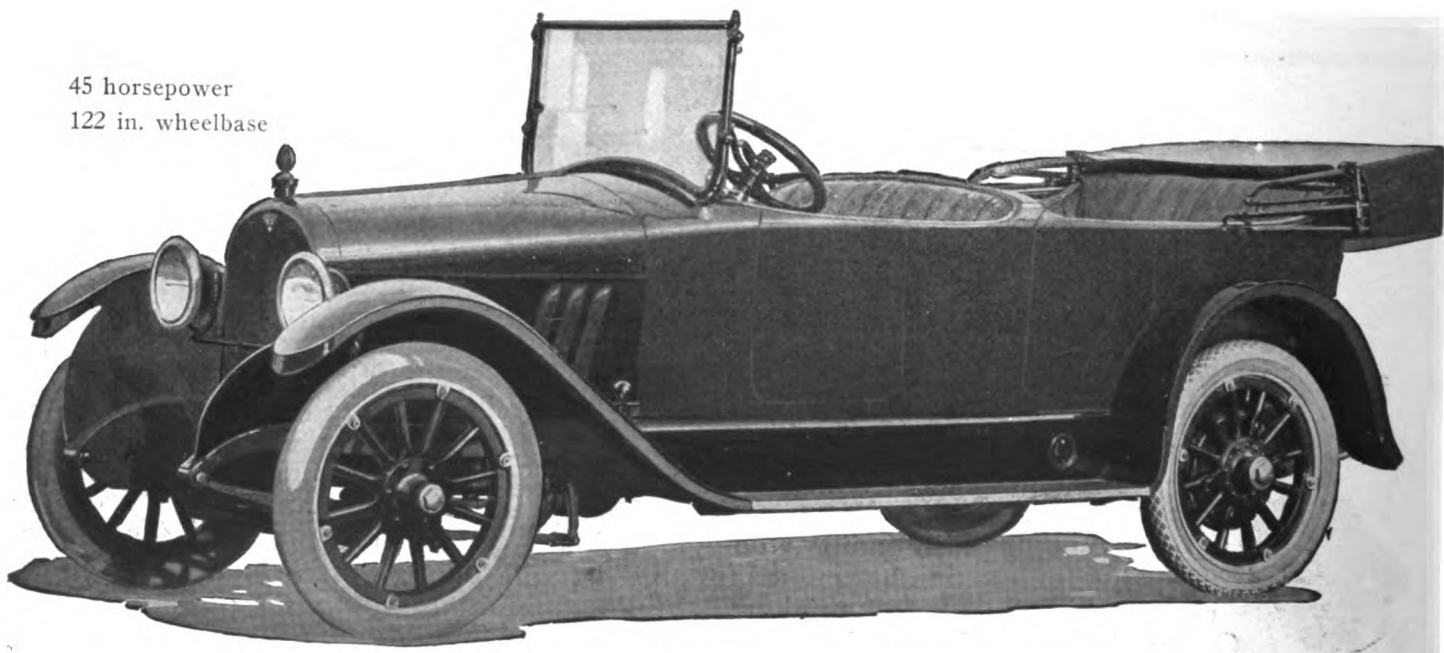

## AMERICAN SIX \$1375

---

**AMERICAN MOTORS CORPORATION, Plainfield, N. J.**

(25 miles from New York City)

Please mention "The Hub" when you write.

Digitized by Google

# Wanted! Quality Plus Quantity

## Norton Grinding Machine

At the plant of the Maxwell Motor Company, New Castle, Indiana, they wanted to increase their production and yet maintain the quality of the output. They did it by using a Norton Grinding Machine.

The parts ground are universal joint yokes. With a 60 M. wheel 2 1/4 in. face, 18 in. diameter, running about 1,500 r.p.m., with work rotating at 100 r.p.m., the output is 15 yokes an hour.

Have you a similar problem which requires speed as well as precision?

You will find the answer in a Norton Grinding Machine. Ask one of our special service men to talk it over with you.

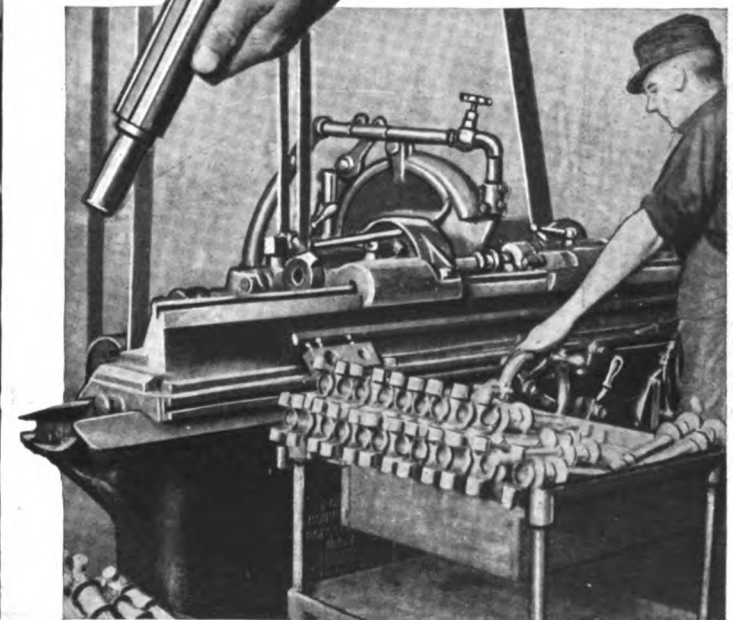
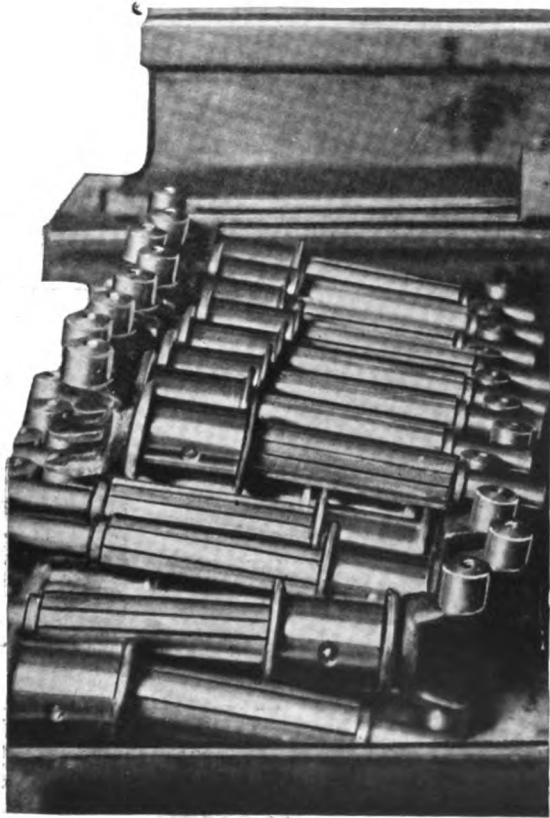
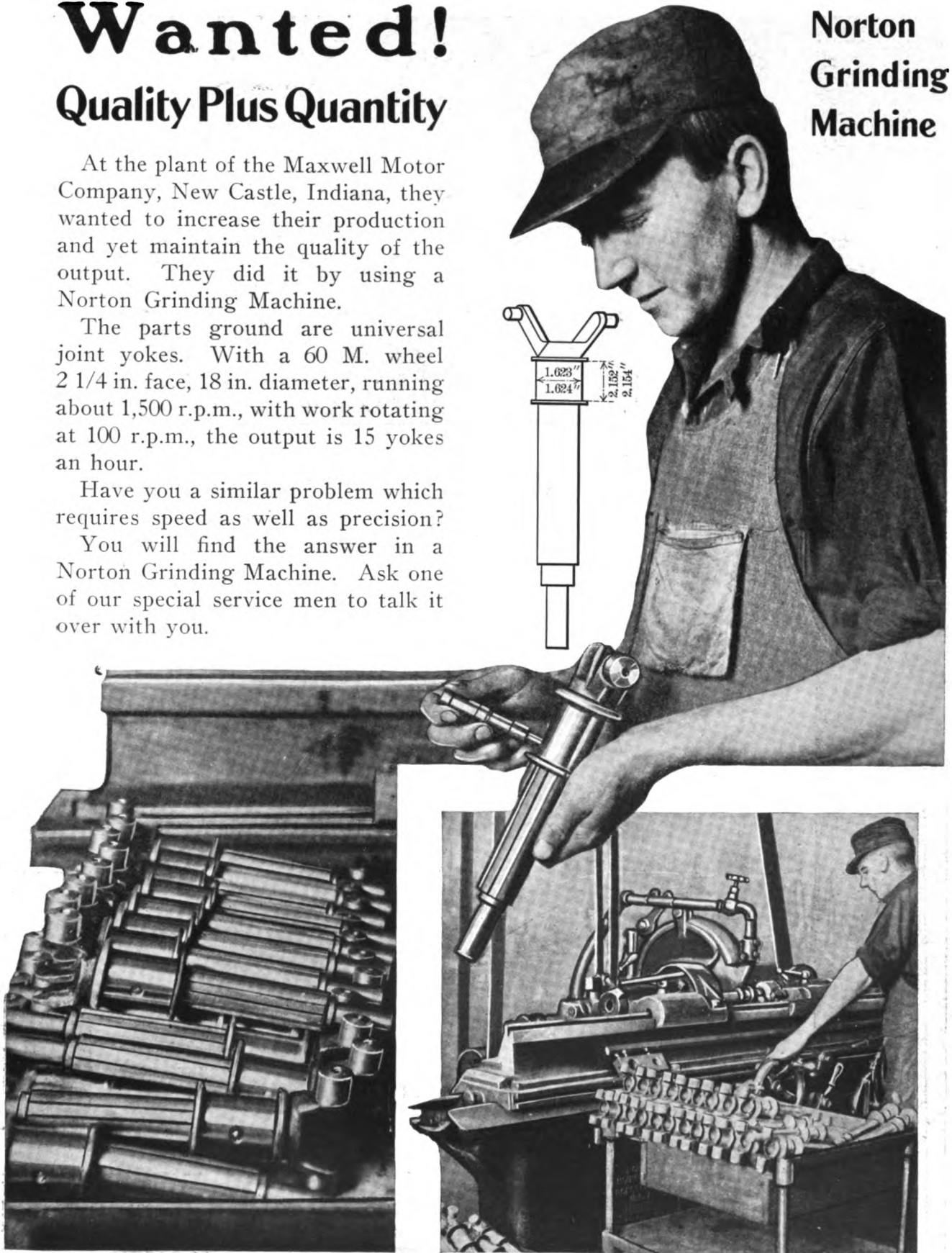
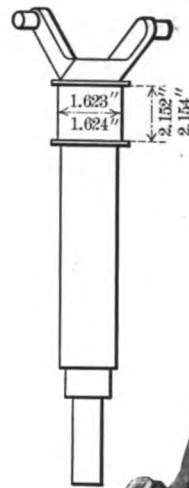

### NORTON GRINDING CO., Worcester, Mass.

Chicago Store—11 North Jefferson Street

AGENTS—Vonnegut Machinery Co., Indianapolis; Robinson, Carey & Sands Co., St. Paul and Duluth; Manning, Maxwell & Moore, Inc., St. Louis; The Motch & Merryweather Machinery Co., Cleveland, Pittsburgh, Cincinnati and Detroit; Eccles & Smith Co., San Francisco, Portland (Oregon) and Los Angeles; Henry Prentiss & Co., Inc., New York, Boston, Rochester, Buffalo, Syracuse, Scranton; Canadian Fairbanks, Morse Co., Montreal, Toronto, Winnipeg, Vancouver; Alfred Herbert, Ltd., Coventry (England), Paris and Milan; F. W. Horne Co., Tokio, Japan; The W. E. Shipley Machinery Co., Philadelphia; Kemp Machinery Co., Baltimore; C. T. Patterson Co., New Orleans; Post Van der Burg & Co., Rotterdam; Iznoskoff & Co., Petrograd, Moscow and Ekaterinbourg, Russia.



# MERITAS

---

## LEATHER CLOTH

### Write Us About the Leading Leather Substitute

We don't offer you merely one or two grades of goods and try to make your business fit the samples—we make such an extensive line of Meritas Leather Cloth that we can submit samples suited to your particular requirements.

Every carriage and automobile upholstering weight, finish, color and grain in a leather substitute can be had in Meritas Leather Cloth.

We operate the largest organization (five plants) making goods of this character.

Meritas Leather Cloth is readily identified by the trademark on the back of the goods—look for it.

**Write for samples  
State your requirements**

**The Standard Oil Cloth Company**

**INCORPORATED**

**320 Broadway**

**New York**





---



---

T H E

---



---

# United States Government Canadian Government British Government

have all ordered and are using Pettingell Machines, and will soon place orders for many more.

If you want dependable machines that are recognized as the Standard for quality and production the world over—you will

## Eventually Buy Pettingell Machines

If you would save time, money and disappointments do it now  
Over 7,500 in daily use and not a disappointed customer

THIS FACT SPEAKS VOLUMES  
When you want the best order PETTINGELL Machines

Bevel and Mitre Saw Tables                      Improved Saw Tenoners  
Irregular Shapers

---

Automatic Power Hammers                      Friction Drive Rotary Metal Cutters  
Beading and Moulding Formers                      Rolling Machines  
Foot Presses                      Cornice Brakes, Etc.

---

MANUFACTURED BY

# THE PETTINGELL MACHINE CO.

AMESBURY, MASSACHUSETTS

# Steer Clear

**T**RY to run a car without any lubricants and what happens? Every bearing will shriek like a lost soul till friction ruins it. Put in grease or oil and what happens? The car runs without squealing, but, even so, somehow the bearings wear. Why?



Because steel cannot be polished to absolute smoothness. The brightest, smoothest looking parts are full of little microscopic holes and protruding points. It is these grinding over each other that create friction. Oil or

## Joseph Dixon

Dept. 123 G.

Established



Please mention "The Hub" when you write

# of the Scrap Heap

grease by their very nature can only smear these over, make them slippery. They still wear and break off.

## DIXON'S GRAPHITE Automobile LUBRICANTS

absolutely obliterate these microscopic roughnesses. Dixon's *selected flake graphite* fills these holes and builds up a smooth, oily veneer around the little protruding points until the whole bearing is smooth beyond description. No other graphite has this quality. Dixon's selected flake graphite is the only graphite that has the peculiar thinness and flatness of flake, a toughness and elasticity that will make it build up and not adhere to itself, ball up or pack. Dixon's Graphite Automobile Lubricants are the only automobile lubricants made that contain this rare form of graphite flake.

Why? Because the Joseph Dixon Crucible Co. are the only graphite workers in the world who have facilities for producing this peculiar form of graphite flake free from imperfections. That's pretty strong, but it's a fact.

We suggest that you get acquainted with this line by first trying out Dixon's Graphite Transmission and Differential Grease No. 677. Talk it over with us; we know just what you need for every part of your car. Write today for booklet.

# Crucible Company

## Jersey City, N. J.

1827



Every 60 Minutes  
of Daylight  
Counts Just Now

Don't Waste Precious Minutes  
Needlessly Changing Tools.

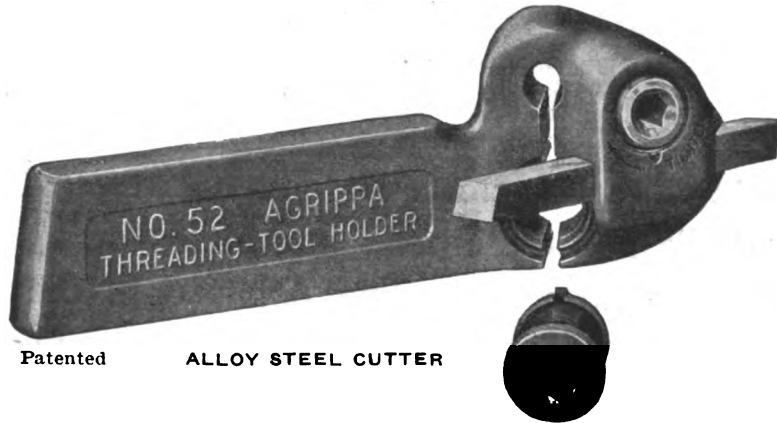
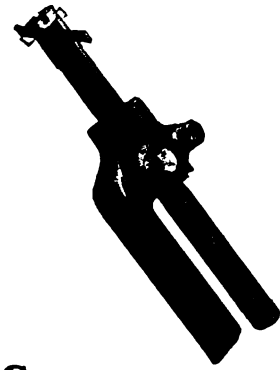

Williams' "AGRIPPA" Threading Tool

with Lockable-Spring Head can both prepare and finish a threaded piece. It affords either rigidity or flexibility as required and permits you to rough turn, finish and thread without removal from the tool post.

Machine tool time is now priceless. Conserve every moment possible by largely eliminating shaping, sharpening and shifting of tools.

USE ONLY

Williams' "AGRIPPA" Tool Holders

"THE HOLDERS THAT HOLD"

They can be supplied promptly from your dealer's  
stock or from ours

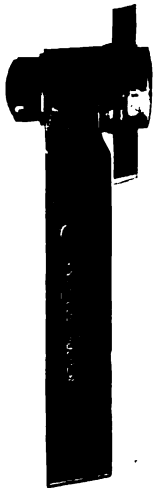

Please mention "The Hub" when you write.

# The Hub

Vol. LIX

NEW YORK, JULY, 1917

No. 4

Published Monthly by

## THE TRADE NEWS PUBLISHING CO. OF N. Y.

PAUL MORSE RICHARDS, *President* G. A. TANNER, *Secretary and Treasurer*  
EDISON BUILDING, COR. ELM AND DUANE STS., NEW YORK

THE HUB, a monthly authoritative journal on all subjects pertaining to the vehicle industry from its engineering and construction viewpoints. It publishes information of live interest to manufacturers of motor vehicles, trailers, carriages, wagons, the accessory trades, repair shops and garages.

Subscription price for the United States, Mexico, Cuba, Porto Rico, Guam, the Philippines, and the Hawaiian Islands, \$2.00; Canada, \$2.50; payable strictly in advance. Single copies, 25 cents. Remittances at risk of subscriber, unless by registered letter, or by draft, check, express or post-office order, payable to the order of THE TRADE NEWS PUBLISHING CO.

For advertising rates apply to the publishers. Advertisements must be acceptable to publishers. Copy for new advertisements must be received by the 25th of the preceding month. All communications must be accompanied by the full name and address of writer.

Entered in the New York Post Office as Second-class Matter

## General Business Conditions

The most important feature of the business situation just now is the satisfactory progress being made by the crops. Although they had a late start, on the whole the outlook for all crops has seldom been better than it is now. There are few spots in the country where a good yield is not promised.

The volume of business is enormous, and on the whole increasing. The reactionary symptoms which have been noted in some quarters merely represent a shifting of activity. May building permits in principal cities fell off over 30 per cent as compared with May of last year, but inability to get steel and other materials had more to do with it than even the high cost of materials. The automobile business has been unfavorably affected, but the truck business has been greatly stimulated and aeroplane construction will give work to many shops.

The government requirements in the steel industry are seriously interfering with private business and have caused insistent bidding for pig iron and steel at prices that have seemed to have no limit. The spectacular figures are given more importance than they deserve, as they relate to early deliveries and apply to a comparatively small volume of business. The steel mills are so completely sold up that there is but little product or capacity available, and the consumer who is trying to break in for early accommodation has a hard time in getting his wants supplied at any price.

The producers of steel, oil, coal and copper have been on tenter-hooks over the price situation at Washington, which has gotten beyond the question of prices upon this government's own supplies, and now includes prices upon supplies for foreign governments and the general market.

Announcement has been made of an agreement between the coal operators and representatives of the government to have prices fixed by a commission, and some such arrangement will probably be reached upon the other principal commodities.

## Our Waste Would Pay for the War

Director Manning of the Bureau of Mines puts the coal waste of the country at \$500,000,000 a year—a moderate figure. Modern steam plants can use 20 per cent of coal energy, but many engines use only 6 to 10 per cent. Our coal loss in home, factory, ship and train may easily be more than half a billion.

Never has a nation been so prodigal as ours. We spill at spigot and bung; both in production and consumption. We sack our wealth of white pines and import insect pests to attack the remnant. We urge farmers to plant for the war and leave them without help to save what they plant. We squander gasoline in joy-rides, heedless of when our supply will be exhausted, or of what will replace it when once used up.

If from this conflict into which we have been drawn we learn to cut down waste, the economy will soon pay the money cost of the struggle. If, depriving no one of any necessity, we could eliminate all waste, we could almost pay for the war month by month as it goes along.

## Reducing Car Shortage by Overloading

One of the war efficiency measures adopted by the war board of the railroads is that of encouraging shippers to load cars beyond their rated capacity. An excess of 10 per cent uniformly applied in this way, it is figured, would be equivalent to releasing immediately 200,000 new cars for urgent service.

One railroad during April last, according to the car service commissioner's report, hauled 2.92 tons of freight more per car than during the same month a year ago, thus saving the use of 58,473 cars. In May the same road hauled 1,414 pounds more per car of L.C.L. freight than during May, 1916, thus effecting an equivalent saving of 6,319 cars. More than 19,000 empty cars have been delivered directly to railroads suffering from a serious shortage of cars by means of trainload movement. The total number to be delivered in evening up the supply is 34,245.

During the month of April the railroads produced and delivered more than 3,000,000 ton miles of freight transportation in excess of their performance in April, 1916. This result was accomplished with the movement of 4.3 per cent more locomotive miles and 5 per cent more freight car miles, resulting in an increase of 66 tons or 10.4 per cent per train.

### Need of Code for Forgers

Few automobile engineers and draftsmen are well enough versed in the minute details of forge and machine shop practice to be able to designate on drawings many of the things which are necessary for an intelligent and satisfactory production, according to E. J. Frost, of the Frost Gear & Forge Co., of Jackson, Mich., expressed in a paper read before the American Drop Forge Association at its annual meeting in Cleveland in June, of which the following is a brief summary:

It is probably due largely to this lack of essential detail that there is often such a wide divergence in prices quoted, because one estimator sees ways to cheapen his product and still comply with the blueprint requirements, while another competitor proposes to supply a better forging at a higher price. Usually the purchasing agent will select the lowest bid, ignoring the fact that possibly the highest price quoted would have saved several times the difference in the machining cost.

Forge people are facing new problems, due to the automobile industry, and the sooner they set about to correct some of the evils that have been the result of rapid development, the sooner will end the needless controversy, rupture of business relationship and financial loss. The speaker picked out some examples to illustrate how standardization could be handled and expressed the hope that a code could be formulated acceptable to all interests and placed in the hands of engineers and agents, with the understanding that when the blueprints of customers do not specify, the code will be followed. One recommendation was that practical drop forgers be called for consultation while new designs are being worked out, that at least preliminary drawings or sketches should be sent to prospective sources of supply to get constructive suggestions and avoid revising drawings and details. He knew of cases where if this policy had been followed the saving would have been enormous.

In a case of large automobile forgings, such as axles, crank and cam shafts, tolerances and amounts for finish should be established and any requirements beyond these should call for a corresponding increase in price. The recent tendency has been to compel drop forgers to produce axles of such refinement that machining costs are brought to the lowest possible amount. This would be satisfactory if the price was commensurate with the extra work. Mr. Frost held that an overall tolerance of  $\frac{1}{8}$  in. should be as close as required from king bolt to king bolt center, although some manufacturers were requiring  $\frac{1}{16}$  in. In regard to twist in an axle, some purchasers require that yokes come absolutely to gauge, but he believed this practice unfair unless an additional price is paid. Various other specific cases were referred to in which there are likely to be controversies between the drop forger and the customer in the forge practice shop, which would be eliminated were standard specifications followed. In conclusion he made the following recommendation.

1. That a committee be appointed on standardization of designs and drawings, whose duty it shall be to formulate a working code on forging practice, if possible introducing a set of symbols to define accurately the quality of surface required and method to be employed in machining.

2. That it shall be the duty of this committee to have printed, at the expense of the association, as many copies of this code, after it has been approved by the executive committee, as may be required to send to customers.

3. That bidding be refused on blueprints which do not reasonably conform to the code.

It was suggested in the discussion that standard tolerances be provided for certain work so that different shops would not submit bids based on different tolerances. One speaker pointed out that many manufacturers are now overcoming some of the trouble referred to in Mr. Frost's paper by securing forging drawings to work on, these being furnished by the buyers. At the conclusion of the discussion a motion that the next president be instructed to appoint a committee on standards was adopted.

---

### Hickory Values Continue to Increase

At no time during the past decade has there been any such situation in the hickory market as exists at the present time. There is an urgent demand for hickory handles, spokes and other hickory product of all kinds, a demand big enough in volume to keep all the plants in the country busy. On the other hand, the supply of raw material in the hands of manufacturers and coming forth to market is smaller than has been known at any time perhaps in the present generation.

This means that, not only are the stocks in the hands of manufacturers reduced to practically nothing, but the farmers who heretofore could be depended upon to get out and market some hickory during the winter season are not paying any attention to the matter this year and can not be induced to devote time and energies to cutting and hauling hickory. They have work to do on the farm which is of more interest to them, consequently the only way the hickory handle and spoke man can get wood is to go out and buy tracts and hire men and buy teams to cut the material in the woods and haul it in themselves.

According to Wood Turning, hickory values have increased as compared to last year about 20 per cent. There have been recent increases in items of cost affecting handles that have necessitated a 10 per cent addition to prices, and generally speaking prices as compared to this time last year are 20 per cent higher. Even at that there is a question of whether hickory manufacturers will be able to get a fair profit out of the business. They have to pay more for their help; machinery and supplies cost more, including everything from garnet for the sand belts to the glue with which it is put on, the advances in these items ranging from 100 to 300 per cent. These, together with the increased cost of timber, and the increased wages being paid, make it imperative for those producing hickory to revise their prices upward in accordance.

---

### Chinese Coach Builders Now Making Motors

After 66 years of activities the foremost horse-vehicle landmark in China is now recognizing the steady advancement in the sale of motor cars at Shanghai. This pioneer establishment originally afforded all the facilities of a successful American livery stable, but subsequently added a coach making department under the supervision of a number of foreigners, employing 350 skilled Chinese workmen. More recently the coach builders have been extensively employed in making motor car bodies ranging from commercial vans and small runabouts to large limousines. The horse vehicle features are now gradually yielding to the steady encroachments of the automobile department, which is conducted by an American expert.





**MOTOR HEARSE**  
Built by Janesville (Wis.) Carriage Works

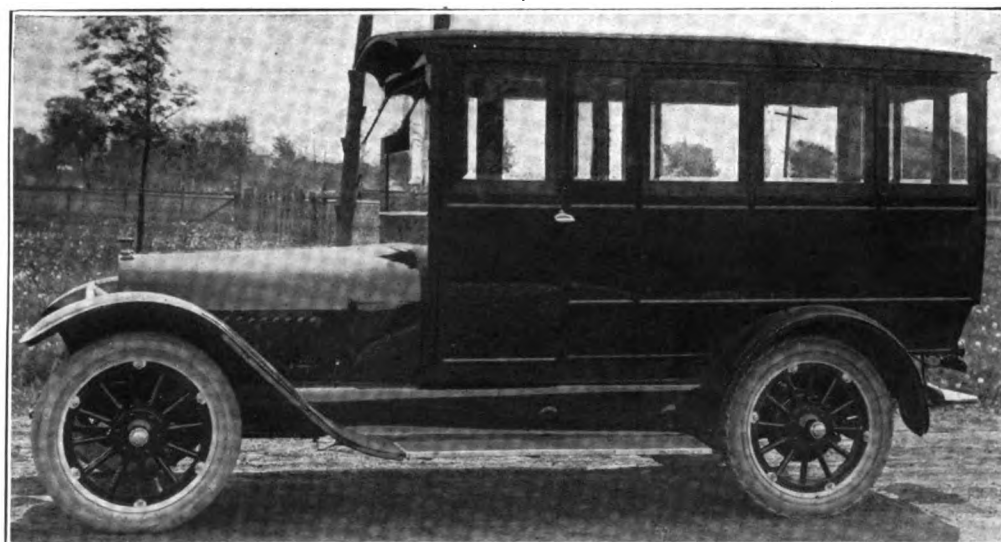

**MOTOR BUS**  
Built by Janesville (Wis.) Carriage Works

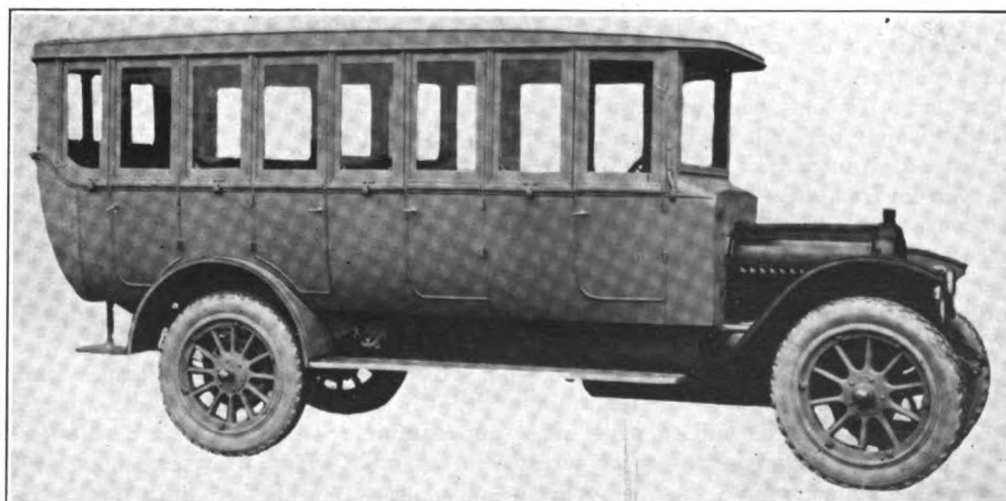

**MOTOR BUS**  
Built by Mifflinburg (Pa.) Buggy Co.

## Standard U. S. Army Ambulance

Official Specifications For a Body to Fit Any Chassis.  
Furnished by the Department of Military Relief,  
American Red Cross, Washington, D. C.

(Reproduction of blue print on opposite page)

### General Provisions

1. The materials called for must be of the best and highest grades mentioned in the specifications, and the work must be thoroughly and faithfully executed in all its parts.
2. Inspection: The material and workmanship will be inspected as work progresses by a representative of the Medical Department.
3. Lumber: Special care must be observed that all wood is well seasoned.
4. Unless otherwise distinctly stated in the body of these specifications, the kinds of lumber used for different purposes will be as follows:
  5. All wood stock in body proper will be ash, maple, beech or birch, of the first quality, for front boards, side boards, lazy backs, rails, and all wood work not otherwise specified. Flooring to be of pine of first quality. All lumber to be of standard woods, first grade specifications.
  6. Ash bows supporting top to be of XXX ash.
  7. All cross bars, front and rear sills to be of best quality hardwood specifications, ash or maple.
  8. All steel angles to be of proper size and best quality of steel. All other irons to be of open-hearth, soft American steel unless otherwise specified.
  9. Best American soft iron for clips, bolts and rivets. All fastenings of steel or wood as required, to be bolted, screwed or riveted. No nails to be used throughout.
  10. Paints and oils of best quality of their respective kind and strictly pure.
  11. All interior posts to be of first quality northern white ash.
  12. All interior closets to be as specified in original specifications.
  13. Water tanks to be as originally specified, but made of No. 20 galvanized iron with reinforced seams. Top of tank at front ends to have cap for filling, and on the front, at the bottom, there is to be a  $\frac{3}{8}$  in. brass spigot. Spring over tank to keep tank from jostling. Small brass handle to be placed on front of tank, just above spigot. All tanks to be oval in design.

### The Body

1. Capacity: Four persons prone, or eight persons in a sitting posture. Length of body over driver's seat, 9 ft. 8 in.; length of body back of driver's seat, over all, 8 ft. Width of body over all, 5 ft.; height of body, 5 ft. 9 in.; top extends front 2 ft. 2 in.
2. Bottom frame work: Two 2 x 2 x 3/16 angle iron sills, reinforced and riveted to side boards, extending lengthwise whole length of body. Width over all, 46 in. with cross sills also reinforced on both sides by angle irons resting on top of side sills and bolted and riveted thereto. Sides of sills to be suitably riveted and strengthened by angle irons to prevent all warping or checking. All cross sills to be suitably bolted to sills running lengthwise, through bottom boards and to panel irons above same. Bottom boards under gas tank to be screwed in separate from rest of floor so they can be removed—tank space, 20 x 38 in. under seat. No wooden cover over gasoline tank. Cushion to cover same.

3. All studs and posts to be of ash, same size as in original specifications.

4. Top slats to be of soft wood 8 ft. long 1 $\frac{1}{4}$  by  $\frac{3}{8}$  in., screwed to bows, one inch apart around bend and three inches apart over the flat part of top.

5. Bows. Six long bent bows of ash,  $\frac{7}{8}$  by 1 $\frac{3}{4}$  in., first, second, and third bows to extend to bottom of extension sills, and clipped to sills with 1 by  $\frac{1}{8}$  in. wrought iron clips; fourth, fifth, and sixth bows to extend to bottom of the deck sills, fastened in same manner. Mouldings over curtains all around top securely fastened with screws.

6. Panels: Panelling at side of driver's seat, between first and second bows, 22 in. from bottom of  $\frac{1}{2}$  in. basswood. At right-hand side of seat there is to be a locker with three shelves for carrying supplies, 1 $\frac{1}{2}$  in. strips on 2 lower compartments, 4 in. strips on two upper. This locker to open over front seat and to be fastened with a hasp and staple.

Between first and third bows, there are to be compartments on each side for water tanks. Doors in front of these compartments to swing and to be provided with hook and cockeye. On these doors are two thin iron plates, 1 $\frac{1}{8}$  x  $\frac{1}{8}$  in., fastened with rivets. There are also to be compartments directly under longitudinal seats with doors hinging from bottom of body and opening toward the center of body, fastened by hasp and lock to seat-sill. Trap door front section of seat, hasp and staple on top.

There is to be a division one-half way between driver's seat and tail gate in each of these compartments. Lower side panel,  $\frac{3}{4}$  in. hard wood; the side panels above deck to be  $\frac{1}{2}$  in. basswood. Lazy back at side to be of hard wood,  $\frac{3}{4}$  x 6 in. wide. These lazy backs are upholstered on the inside as specified in No. 15 of General Provisions.

Lazy backs are to be notched  $\frac{1}{4}$  in. over bows to make them flush with panel. Rear posts are to be bound with angle iron to prevent splitting. Hinges are to be above rear sills, tail gate the same height as deck, making proper allowances for iron. Hooks are to be bolted to tail gate and made to engage with cockeyes to fasten when closed.

7. Step-board: Is to be made independent from tail gate and to fold up with same. To be built so as to close automatically when tail gate is thrown up. To be thoroughly braced with folding irons.

8. Litter irons: Are to be provided on each side of the body and are to be fastened to the third and fifth bows with 5/16 in. bolts. Irons are to be made of 1 $\frac{3}{8}$  x  $\frac{3}{8}$  in. steel, 13 in. high, 3 in. wide on the inside, to have a strap attached to bows to retain litters in place.

9. Center posts supporting litter carriers are to be made of best quality northern white ash and ironed solid to bottom and top.

### Trimmings

1. Front cushion: To be 18 x 48 in., made regular style with springs, to be covered with heavy canvas. Tops and side of this cushion to be covered with Spanish leather of quality submitted with order. Regular roll on the front edge of cushion. Top of cushion is to be stuffed with hair not less than 3 in. in thickness. Lazy back is to be covered with Spanish leather and padded 3 in. thick with hair. Inside seats are to be made 17 in. wide, furnished with box seat cushions, same general make as sample body. These springs are to be placed three springs on a drop-bar. Springs are 3 $\frac{1}{2}$  in. high, placed 4 in. from center to center, filling the entire top of seats. Depth of frame for spring is 2 in. Springs are to be covered with

STANDARD UNITED STATES ARMY AMBULANCE

(Description on opposite page)

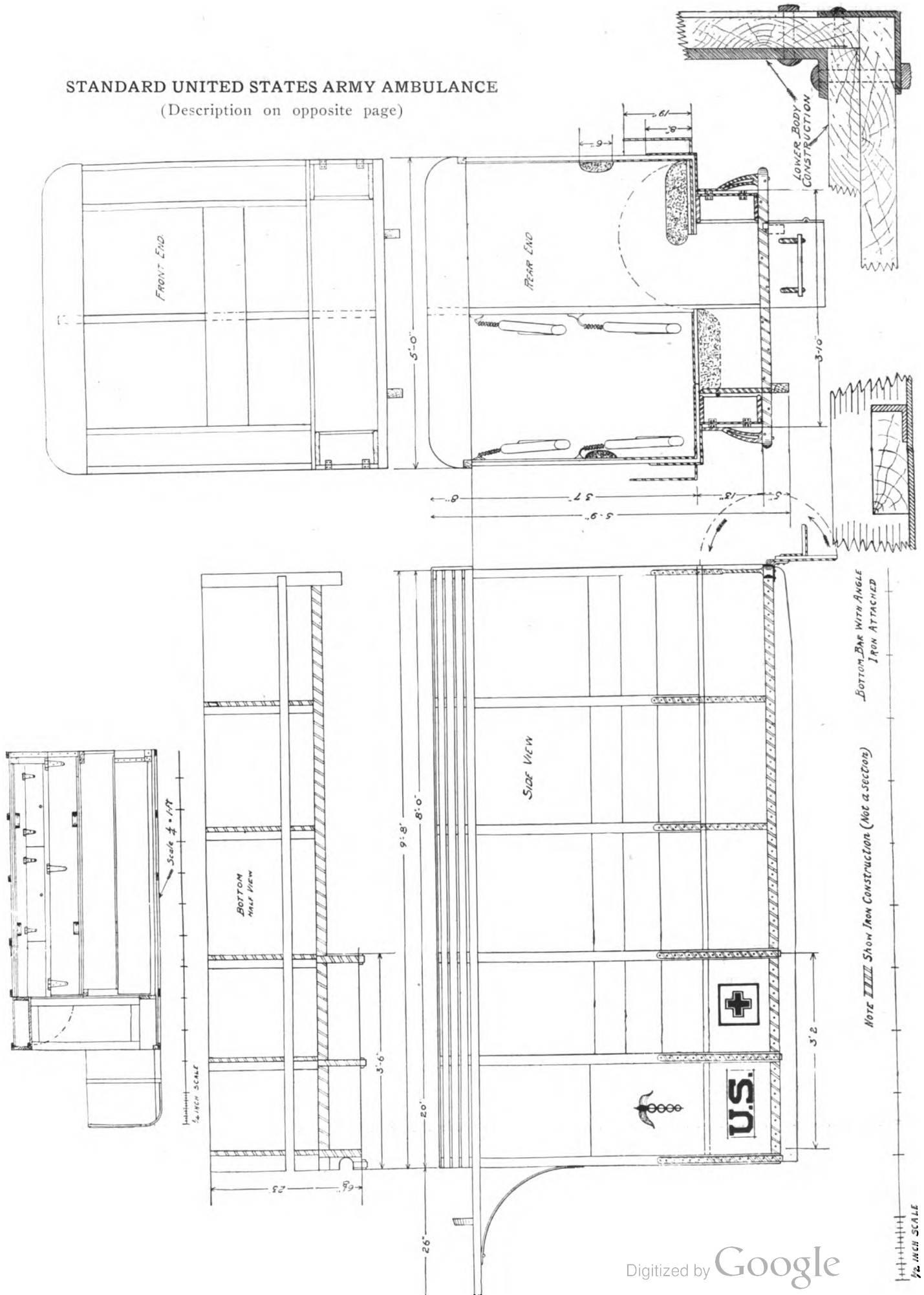

heavy canvas, securely attached to frame. On this is placed a hair filling of sufficient thickness to make a comfortable cushion. Top and sides of cushion are to be covered with Spanish leather; lazy backs are to be made same as front lazy back.

Spring roller curtain, made of canvas, provided with snaps to fasten down. This canvas to be selvaged on both edges and a hem turned up at bottom so as to receive an iron strip. (This curtain is placed back of driver's seat. Rear curtain to be made of brown canvas tacked to rear head piece). This curtain to roll up and fasten with three straps, hooks and rings. Curtain hemmed all around with 2 in. hem. Curtain to extend 4 in. below deck and 4 in. around with a 2 in. hem. Brass grommet eyelets in bottom corners. These eyelets are provided with tie-ropes. All ropes spliced in grommet and around at end to prevent unwinding. Where a curtain is tacked on to head-piece, there is to be a drip molding screwed over curtain.

Side curtains are to extend 4 in. front of second bow and to rear of body and 4 in. below deck panel. These curtains are tacked on top and side rail. 2 in. hem on ends and bottom. Three grommet eyelets with rings furnished with tie-ropes at bottom of curtain. These curtains roll up and are held in position by five straps, hooks and rings. One small curtain by driver's seat to extend front of body and lap over front storm curtain, tacked on the inside of side top rail and extend to chassis frame. 2 in. hem on side and bottom of curtain; 20 x 21 in. pyraline, light sewed in and reinforced. Curtains held in place by brass fasteners on front of post and front curtain. These curtains roll up and fasten with two straps, hooks, and rings. Front storm curtain to extend from hood to 4 in. below the top of dash, and to be the width of hood. 4 in. hem on both sides and bottom; 40 x 21 in. pyraline, light sewed on this curtain and reinforced.

2. All canvas to be special No. 95 tan textol, waterproof, and mildew proof, and all seams and hems to be double stitched, all same as in sample body. Straps to litters in outside carriers. Curtain straps with hooks in place of buckles. Straps, leather, front and rear, fastened to side board to hold lowest litter in place. Corrugated rubber on front and rear lower tier. Irons to hold litters—upper tier curved. Bolt and cotter pin to hold seat when turned back.

#### Painting

All woodwork to be primed with a coat of pure linseed oil and lead and stand until thoroughly dry before the irons are put on the inside body. To be finished natural wood with three coats of varnish and to be thoroughly dry between coats and sanded. All other parts are to receive two coats of pure lead and oil and all defects puttied and sanded. Then two coats of olive green, one coat of glaze, one coat of finishing varnish. Ample time should be given between each coat to dry.

#### Lettering

The letters "U. S." are to be laid on in aluminum leaf, full block letters, 4½ in. high with a 1 in. square period after each letter. All work to be done in a workmanlike manner.

Number of plate on body.

"Maximum, 8 patients" placed on outside rail (stencil).

Red Cross: In the second panel from front, lay on an 8 in. square aluminum leaf. In the center of this panel a

red cross, each bar 6 in. long and 2 in. wide. Then dry and varnish.

Caduceus: In the first panel, above "U. S.," to have a caduceus 6 in. high in maroon laid on aluminum leaf.

#### Blue Prints

Blue Prints: Drawings of elevations, sections and minor details of the ambulance referred to accompany and form a part of this specification. They are to be considered in connection therewith.

#### Repair Body

The specifications of the repair body are to be the same as the ambulance body, with the exceptions of drawers and work bench on interior of body. The chest of drawers, eight in number (six only shown in blue print, the upper two being made into four), is 21 in. high, 24 in. deep, and made to fit inside the body inside the seat line. These drawers are made of ¾ in. maple and the top of the chest is made of 1¾ in. maple, as this is used for a tool bench. Between the seats at the bottom, another drawer is made of ¾ in. maple, which works in a frame to fit this space.

When bodies are furnished for this purpose, the compartments underneath the seat are made full width, the spring cushions are to be left out and loose canvas cushions furnished instead. The compartments underneath the seat and drawers are suitably divided into smaller compartments for carrying spare parts. Right and left-hand sides front ends of longitudinal seats to have base trap doors opening toward floor with hasp and staple. Left-hand rear to be made without divisions and to have trap door under seat. Right-hand rear to be divided into four compartments of equal size and to have trap door from top. The drawers are to be fitted with two drawer pulls, hasps, staples for padlocks, card holders on the outside of drawers. Ample space should be allowed in construction of drawers to admit of their being easily opened under variable weather conditions.

[Side and rear views of United States Standard Army Ambulance, built by the H. H. Babcock Co., Watertown, N. Y., were shown in the April issue of *The Hub*.]

### Would Invest Big in Auto Plant

It was recently announced by Tampton Aubuchon, general manager of the Louisville Industrial Foundation (Million Dollar Factory Fund), that a special committee was appointed to prepare a brief on Louisville as an automobile manufacturing center, and to make a special effort to secure a large automobile factory. The brief is being prepared now by the Foundation statistician and will shortly be published and distributed among the automobile fraternity throughout the country.

The committee, because of the increasing purchasing power of the south, the development of good roads, and the fact that Louisville is a good distributing point and also a good location in which to assemble raw materials, has concluded that an automobile factory may be successfully operated there.

Recently the Ford Motor Co. established an assembling plant in Louisville, and the Dixie Motor Car Co., a manufactory capitalized at \$400,000, also began operations and has been, thus far, very successful.

The Foundation plans an extensive advertising campaign and is prepared to invest a considerable sum of money in an automobile factory.

# The Coloring and Coating of Metals

## Various Processes of Producing Surface Finishes on Metals to Improve Their Appearance, Including Japanning and Lacquering

By W. A. Ehlers

The coloring and coating of metal is so closely associated with the art of metal treating by heat that any discussion of the latter would scarcely be complete without a brief review at least of the process of finishing metals by coloring and coating. Some of this work requires very little heat. The demand for more artistic and decorative finishes on shop products and the keen competition in the industrial world have given a great impetus to this specialty. Metal coloring and coating not only serve to decorate, but they are often useful in preserving against disintegrating agencies.

All grease and foreign matter must be completely removed before the color or coating is applied.

One of the most common ways of coloring iron and steel is by heat treating the material while in the presence of an excessive amount of air. If large quantities of small parts are to be colored they may be placed in a rotating drum and heated to the proper temperature by means of a gas flame. It is generally desirable to place the work in sand to prevent scratching and produce a more uniform heated product. When only occasional pieces are to be treated the work may be done over a bunsen flame. The temperatures of coloring depend upon the color desired, but steel should not be heated over 600 deg. F., as above that temperature the surface changes back to its original color. The following table gives good average practice:

Color	Temperature, Deg. F.
Pale yellow	430 to 450
Straw yellow	460 to 470
Dark straw	470 to 480
Purple	500 to 540
Blue	550
Dark blue	560
Pale blue	600

Spring steel and wire are often colored by passing the strands through a hot lead bath and then cooling in the air. This method, however, is not entirely satisfactory on account of the tendency for the lead to stick to the metal. Also it is not an efficient method because the temperature carried in the lead is considerably higher than that required to color steel.

Bluing in Nitrate of Potash or Salt—Not always practicable or possible to treat the work by tumbling as indicated above. A bath consisting of sodium nitrate and potassium nitrate heated to the desired temperature in a suitable cauldron furnace is often used instead. The work is plunged into the bath, and after being brought to the proper temperature is cooled by dipping in boiling water.

Bluing in Nitrate of Potash or Saltpetre—A very successful method for bluing iron and steel is to heat the parts in a melted solution of saltpetre, consisting of 10

parts of saltpetre to 1 part of black oxide of manganese. When thoroughly heated to a temperature of 600 deg. F., they are removed from the bath and quenched in plain water. After this the work is dipped in a tank of lard oil and then washed off in hot soda water, using about 1 lb. of soda to 1 gal. of water. After cleaning, the work should be well dried in sawdust and covered with linseed oil to prevent rusting. This method, like the other dipping method, is slow, but it gives a superior finish and one that is used extensively in the manufacture of firearms.

Bluing in Charcoal—Another method of bluing used extensively in the manufacture of firearms is by the use of charcoal. Large cast iron or steel pans containing charcoal to a depth of about 6 in. are placed over a bed of fuel and heated until the charcoal begins to glow or burn slightly. The steel work is imbedded in the hot

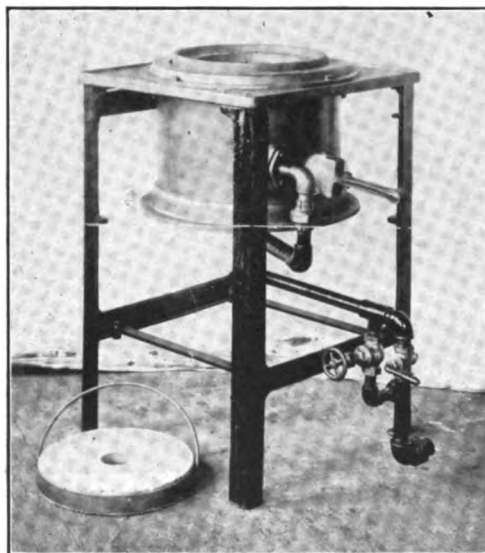

Soft metal furnace for tinning or galvanizing. Also for use with potash or salt

charcoal and when well heated is removed and rubbed briskly with a soft cloth. This operation is repeated a number of times before the proper finish is obtained. The operation is slow and better suited to large pieces of work than small, but the finish is even better than that obtained by means of the saltpetre bath.

Mottling—A very desirable finish is obtained by mottling. The steel parts are heated to a cherry red in a bath of cyanide potassium and then cooled in clear water. A better finish may be obtained if the parts are further treated by boiling them in water, then drying and oiling while hot.

Black or Gun-Metal Finish—This gun-metal finish is employed extensively on many classes of work. It not

Courtesy of Industrial Management.

only gives materials an excellent appearance but serves to prevent them from rusting for a short time.

For rough work where it is not so necessary to have a very good finish the parts are heated in an over furnace to a cherry red and then quenched in cold lard oil. After removing from the oil the work is put back in the furnace, the oil burned off and the pieces quenched in clean cold water.

For a better class of work what is known as a gun-metal finish is used. It consists in giving the surface of the material a thin coating of a chemical solution applied with a brush or sponge. After coating, the work is placed in a steam bath and maintained at a temperature of 100 deg. F. After a slight rust appears covering the entire surface, the work is taken out, placed in boiling water for about 20 minutes and then dried. When this is done a

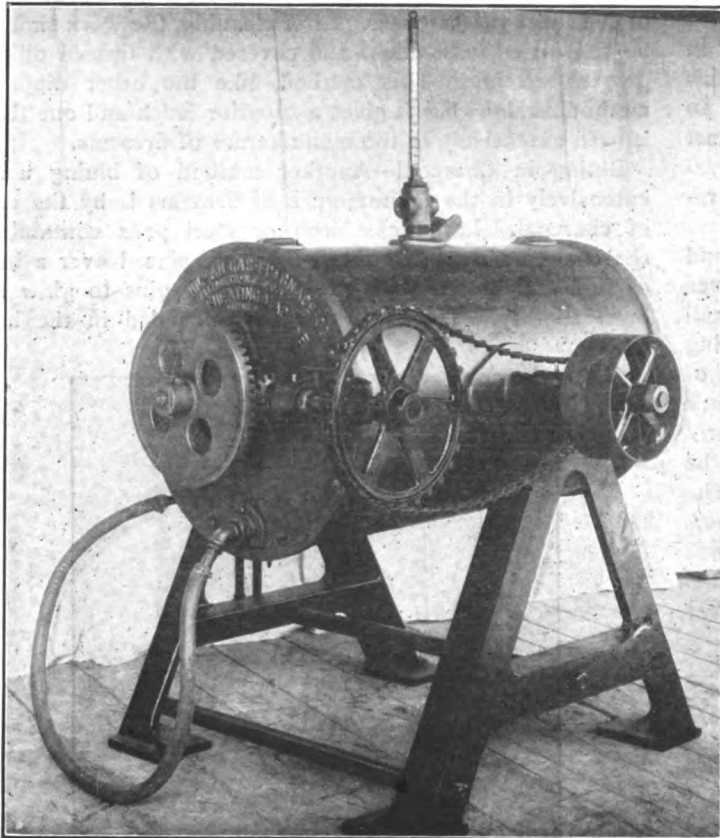

Heating machine to temper colors—gun metal or carbonia finish

coating of black oxide will appear covering the surface. The operation must be repeated several times, scratch brushing the surface between each coating.

Several chemical solutions may be used to produce this "gun-metal" finish, of which the following represent good practice:

Eight parts alcohol, 1 part ferric chloride, 8 parts water; or 3 parts hydrochloric acid, 4 parts nitric acid, 2 parts copper sulphate and 80 parts perchloride of iron; or 1 part each of chloride of copper and chloride of bismuth, 2 parts chloride of mercury, 6 parts hydrochloric acid and 50 parts of water.

With all of the above methods a very thin coating is formed on the surface of the steel. A process adopted by the French government consists in applying chemical solutions which act on the metal causing a thin layer to change its color, the shade depending upon the time of

treating and the temperature. The exact formula for the chemical solutions used is not known.

In all metal coloring of this kind it is of the greatest importance to have the work clean of all grease, dirt, scale and oxide. Grease may be easily removed by boiling the work in hot soda water, rinsing at least three times to make sure that all traces have been removed, and drying. To remove scale from iron use a bath or pickle of 1 part of sulphuric acid to 20 parts of water. After the scale is loosened place the work in a bath consisting of 1 gal. of water to which has been added 2 oz. of zinc and 1 lb. of sulphuric acid, and after the zinc has been dissolved,  $\frac{1}{2}$  lb. of nitric acid.

"Carbonia" Finish—"Carbonia" finish is a process developed by the American Gas Furnace Co., and consists in heating the work in a closed chamber or tumbling barrel in the presence of ground bone and carbonia oil. This method gives a deep black or blue black finish to the steel, and may be varied from a dead black to a lustrous finish. Under the action of heat a portion of the ingredients is absorbed by the metal and gives more of a casing than a coloring coat to the steel.

Small parts may be thrown in loosely and tumbled, but material having projecting surfaces and parts too large and cumbersome to tumble are placed on racks in the machine and held rigidly while the drum revolves. This method is used extensively by one of the largest gun manufacturers for finishing all of the metal work on rifles. It is also widely used on many other lines of work.

Browning and Bronzing Finishes—Several methods of producing a brown color have been tried. The one adopted by the United States government gives fairly good success when used for browning gun barrels. The formula reads: Take 3 oz. each of alcohol, sweet spirits of nitre, tincture of iron and corrosive sublimate; to this mixture add  $\frac{1}{2}$  oz. of nitric acid, and 2 qt. of warm water. The solution is applied with a brush, allowed to dry and brushed out. The operation is repeated several times and then the work is boiled in water and dried. After this treatment the parts are covered with boiled linseed oil to prevent rusting.

A good bronze color on steel may be obtained by covering the work with bronzing salts or a paste of chloride of antimony and letting the parts stand until the desired color is reached. A little nitric acid will add to the color and produce better results.

#### Coloring Copper, Bronze and Brass

Copper is much easier to color than iron or steel and many pleasing effects may be obtained in its treatment. Salts are used principally for this work because they produce the best results.

It is very important to have all copper, bronze or brass thoroughly clean before attempting to color it. The action of the atmosphere on copper causes the formation of oxides and carbonate of copper; sulphur compounds are formed also when the work is exposed to products of combustion. If these coatings are not removed they will cause a streaked appearance on the finished work.

For many purposes the many shades of green are pleasing and desirable. These are produced naturally by the action of moist sea air in contact with copper. The first color to appear is a rust green, which gradually changes



to brown and then to black. To produce the rust green color use 2 oz. chloride of ammonia, 2 oz. common salt, 4 oz. aqua ammonia and 1 gal. of water. This solution will doubtless require more than one application.

Browns are produced in different shades on copper depending upon the length of time the work is immersed. Excellent results are obtained by using  $\frac{1}{4}$  oz. of potassium or sodium sulphide mixed with 1 gal. of clean water. After immersing the work should be dipped in a solution of nitric acid in order to set the color.

Brass is turned gray by using a solution of  $\frac{1}{2}$  oz. of potassium sulphide in 1 gal. of water applied when the work is cold. If the brass is heated to a temperature of 100 deg. F. the color begins to darken and at 180 deg. F. it changes to black.

To produce the black colors many different processes may be used. Two oz. of white arsenic and 5 oz. of potassium cyanide mixed with 1 gal. of water, heated to the boiling point and applied hot will give good results.

Heat-Black Finish—A dead black finish may be applied to brass, bronze or copper and is commonly called "heat-black." It is used for a variety of purposes and in some instances in preference to nickel plating. This process, however, does not work successfully on iron or steel.

The coloring solution is made up of 3 parts water, 2 parts copper nitrate solution and 1 part silver nitrate solution. The nitrate of copper solution is composed of equal parts of water and nitrate of copper. In like manner the nitrate of silver solution is made up of equal parts of water and nitrate of silver. The work to be colored is heated to a temperature of about 250 deg. F. and the solution applied with a brush. Not more than two coats are necessary. After the work has dried and the surface has been rubbed off, a brownish black color will appear. If this color is desired it may be preserved by coating the surface with lacquer. If, however, a dead black finish is preferred, the work must be dipped in a solution of sulphide of potassium. As a final treatment the material is dipped in a solution of 2 oz. of potassium sulphide dissolved in 1 gal. of water, and left in this solution for several minutes. It is then removed, dried in an oven and given a coat of lacquer or wax.

Blue and Violet Color—A blue color on brass or copper may be produced by immersing the parts in a solution consisting of 25 oz. of water and 1 oz. of chloride of antimony, to which is added 4 oz. of hydrochloric acid. The parts should be warmed before dipping and after being removed from the solution they should be rinsed in water and dried in sawdust.

Violet colors may be obtained on polished brass in the following manner: Take 1 oz. of sugar of lead and dissolve it in a quart of water; then dissolve 4 oz. of sodium hyposulphite in another quart of water. Mix these two

solutions together and after heating the parts to be treated to about 175 deg. F. dip in the solution for the proper length of time to give the violet color.

Silver color—For certain purposes a silver color may be desired. The coloring material required for this purpose consists of 3 oz. common salt, 2 oz. cream of tartar and 1 oz. pulverized dry chloride of silver. These are mixed together and brought to the proper consistency by adding water.

Oxidizing—Oxidizing is done much in the same manner as that used to produce green colors. Mix together 8 oz. of hyposulphite of sodium, 8 oz. of double nickel salts and 1 gallon of water, and heat the mixture to a temperature between 150 and 180 deg. F. After removing the parts from the bath, rinse them in water and rub with pumice stone. Browns and blacks are produced in the same way as the normal oxide color.

Mottling—A very pleasing effect is produced by mottling. To do this properly the surface of the brass or copper must be buffed and cleaned thoroughly. Then dip

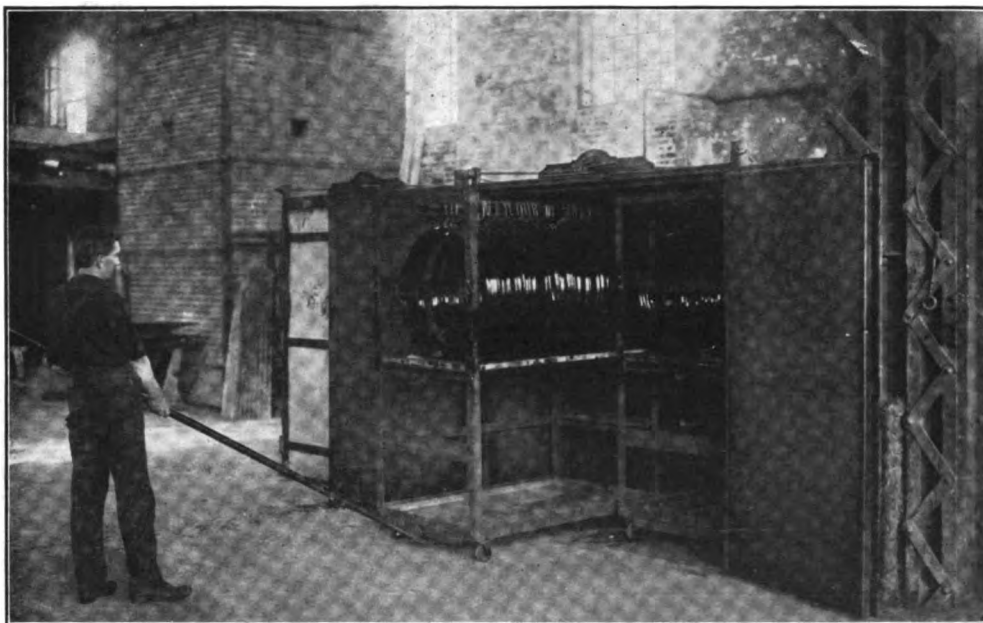

Tire japanning cabinet. Ovens with work charge in same on truck

the parts in a solution consisting of 2 oz. of sal ammoniac, 8 oz. of copper sulphate and 1 gal. of water. After the appearance of a light yellow color dip the work in a solution composed of 4 oz. of salsoda and 1 gal. of water. The surface of this last solution should be covered with lard oil. After removing the parts from the second solution they are put back in the first solution until the green shade appears. The oil will prevent the last operation from spreading over the entire surface and hence produce a mottled effect.

### Japanning

There are many kinds of products requiring a more substantial finish than can be obtained with ordinary air-dried paint. It is often desirable to cover the surface of metal, wood, leather and paper with a hard, strong and well wearing coat. This can be accomplished by what is known as japanning.

Japanning is unfortunately often confused and spoken of as enameling. The two processes are entirely different.

Japanning consists in applying to the surface of an article an adhesive coating and then baking the coating

in an oven at a proper temperature and for a suitable length of time, depending on the character of the work and the color of the japan. When this is done properly it gives to the material a hard wearing surface which is both pleasing and protective.

Enameling, when considered in the true sense of the word, consists in covering a metal surface with a high temperature clay compound and then baking or fusing it in an oven under high temperature, usually around 2,200 to 2,400 deg. F. This process produces a very different surface than japanning.

Japanning has come into prominence recently with the development of the automobile and other mechanical industries, where a hard, protective and pleasing surface is desired. There are a number of so-called air-drying japans. They produce an inferior finish as compared to baked japans and require much longer to dry.

The surface of the material to be japanned must first be properly cleaned and prepared to receive the coating. Cast iron parts should be thoroughly cleaned and also

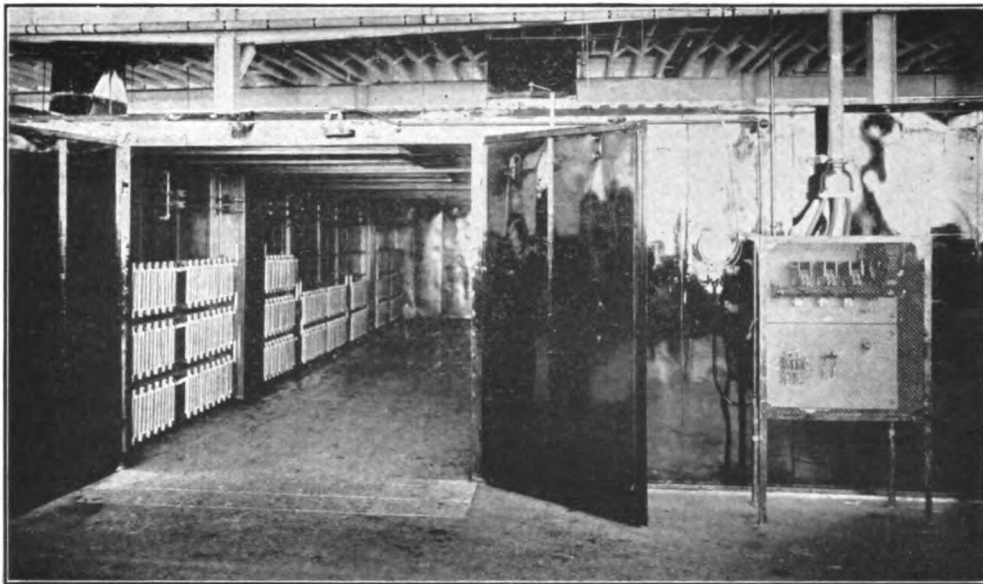

Interior of half of automobile body baking oven with General Electric Co. heaters and automatic control panels. Oven 40 x 20 ft.; 441 k.w.

given a good coat of iron filler. All work should be cleaned of dirt, scale and grease before applying the japan. Dirt and grease may be effectively removed by plunging the work in a solution of boiling lye or caustic soda. Scale and rust may be removed by subjecting the work to a sand blast. Wooden parts are best prepared to receive the japan by giving them several coats of wood filler mixed with oil and then allowing them to dry before coating with japan.

The japan may be applied in three or four ways—brushing, spraying, dipping and tumbling. For the best work and finish the coating is applied with a brush and carefully spread over the surface. It requires a great deal of skill, however, to do this properly.

On large work, particularly where labor is a consideration, the japan may be applied by means of a spray. The liquid is placed in a suitable receptacle and blown out or drawn out in a fine spray covering the work thoroughly and in much less time than it would take to brush it on. There is considerable loss, however, in this method as it is difficult to confine the spray to the work and much

japan is deposited on the surrounding screen. But a large part of this may be recovered and used over again.

Automobile bodies are sometimes coated with japan by using the "Floco" process which consists in "flowing" the liquid on the surface to be covered. The liquid is forced from a tank by a pump and motor into a flexible hose attached to the "Floco" nozzle. The flow is adjusted by a regulator which is under the control of the operator.

The character of finish and grade of workmanship largely determines the number of coats to be given to work in japanning. The first coat is no more than a filler, and covers the pores and rough places on the surface of the material. Each additional coat must be baked and rubbed down before the next coat is applied, and each succeeding coat gives a better and more durable finish.

The baking of japanned work varies according to the color of the coat, the size of the pieces and the character of the work. When the work is placed in the oven and heated the volatile oils which act as the vehicle for the gums are driven off in a smoky vapor, after which the gummy residue of the japan adapts itself to all the inequalities of the surface and on further heating the surface becomes hard and glossy, a condition that it retains after cooling.

The temperature and time of baking depend upon the color and great care must be employed. If heated too long at too high a heat the coatings lose their brilliancy and turn black.

Black japans are usually brought up to 350 deg. F. slowly and the increase then stopped, as experience has shown that this method gives excellent results.

Temperature control is important in baking japans, especially in the lighter

shades. Great care must be taken not to overheat the work; for this reason japanning ovens should be heated by gas fuel and the temperature regulated by thermostats. There are a number of special preparations of japan on the market.

The following table represents good average practice:

Color	Deg. F.	Time to Bake in hours
White .....	160	4
Pale blue .....	175	2 to 3
Pale green .....	175	2 to 3
Pale yellow .....	175	2 to 3
Dark blue .....	225	3 to 4
Dark yellow .....	225	3 to 4
Dark green .....	225	3 to 4
Dark red .....	225	3 to 4
Dark gray .....	225	3 to 4
Dark green .....	250	3 to 4
Maroon .....	275	3 to 4
Brown .....	275	3 to 4
Black .....	up to 600	depending on temperature.

However, there is no secret about compounding such

material and the following recipes for the different colors will give good results:

**Black Japan for Metal**—3 oz. asphaltum, 12 oz. burnt umber, ½ pt. boiled oil, 2 oz. rosin. Melt the asphaltum, stir in the heated oil and umber and thin when cool with 16 oz. of turpentine.

**Black Japan for Leather**—2 oz. asphaltum, 4 oz. burnt umber, 2 pt. boiled oil. Dissolve the asphaltum by heat in a little oil and add the umber ground in oil, then add the balance of the oil and when cool thin with turpentine.

**Black Japan Ground**—1 lb. of asphaltum, 1 lb. balsam of copaibe. Thin with hot oil of turpentine, mix lamp black with oil of turpentine, grind and thin with copal varnish.

**Green Japan Ground**—The desired shade of green may be obtained by mixing together in proper proportions Kings yellow and Prussian blue and the necessary amount of shellac to get the proper consistency.

**Blue Japan Ground**—Use Prussian blue mixed with shellac varnish. To obtain a polish coat add several coats of seedlac varnish.

**Red Japan Ground**—For the first coat use madder lake ground in oil of turpentine. After drying, apply a second coat of lake and white copal varnish; then apply a mixture of copal and turpentine mixed with lake.

**Yellow Japan Ground**—Take Kings yellow and mix with the proper amount of shellac.

**White Japan Ground**—Take 1 part of flaked white of lead and 1/6 its weight of starch, dry both and mix with fine gum ground in parts of 1 oz. of gum to ½ rectified turpentine. After mixing and grinding apply to the work. Then varnish the work with several coats of the following: 2 oz. of seedlac to 3 oz. of gum anise ground to a fine powder and dissolved in 1 qt. of alcohol.

**Lacquering**

In order to preserve the appearance of certain metal articles and prevent deterioration the surface is covered with a thin coating of lacquer and baked. Lacquers are transparent and differ but slightly from varnish, except that the solvent for lacquer is alcohol, while turpentine is generally used to cut varnish. Lacquers are of two

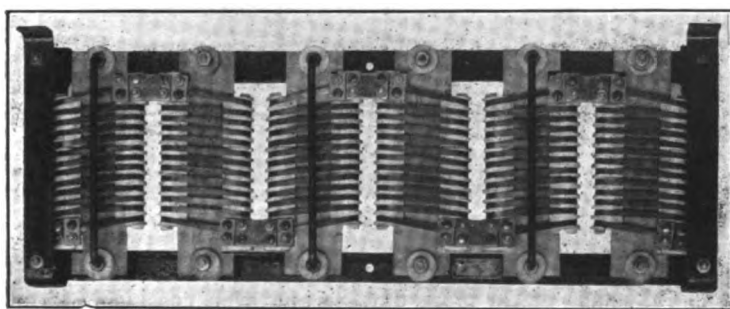

Type A H 3.5/4.2 k.w. 220/240 volts Form B electric air heater General Electric Co.

kinds—pyroxylin lacquer made from cotton fibre, and shellac lacquer which is made from lac, the secretion of an insect found in India. The commercial brands of shellac in use are too numerous to mention here.

Surfaces for lacquering, like japanning, should be thoroughly cleaned and all traces of grease removed. Even

the impression of the finger will often show on the work, and care should be taken to avoid handling the work with the bare hand.

Lacquer is applied by dipping, brushing or spraying. Dipping is used only for the cheaper grade of goods. The object should first be dipped in a bath of equal parts of sulphuric and nitric acid, rinsed in cold water, then

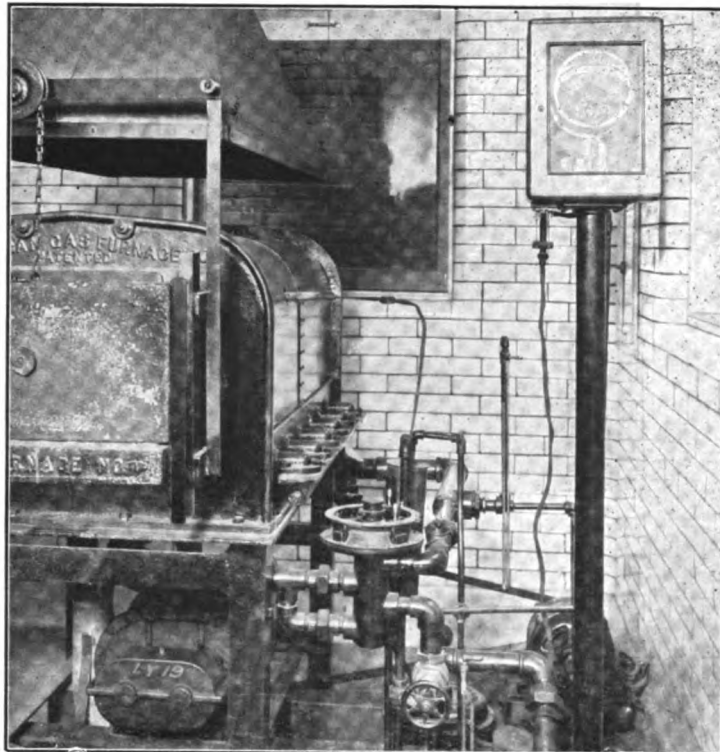

Gas furnace equipped with automatic heat control This device also used for regulating temperatures in japanning ovens—controls temperature to within 5 deg. F.

dipped in hot water, rinsed in alcohol and then dipped in lacquer.

The brushing and spraying operations are simple and similar to those used in the applications of japans. One of the most important things to be considered in baking lacquer is a properly constructed oven. It should be well ventilated so that all moisture and volatile gases may be removed. On first placing the work in the oven, the ventilating damper should be opened wide for a short period and then nearly closed for the remainder of the bake.

Air drying was the customary method used until within the past few years, and the operation was then principally drying or evaporating. More recent developments in the preparation of lacquers require that the drying operation be replaced by a baking operation at a temperature of about 300 deg. F. By this method the lacquer is baked into a solid coat producing a glassy hardness that will withstand almost any test.

**Tinning**

Tinning consists in coating the surface of cast iron, wrought iron, steel, copper, brass, etc., with pure tin or a mixture of tin and lead. The preparation of these metals for receiving the coating consists in removing all grease by dipping in a hot solution of caustic soda and then rinsing in clean hot water. Rust and scale should be entirely removed by a sand blast or by dipping in a hot

solution of weak sulphuric acid (about 1 part of acid to 30 parts of water).

Castings are coated by dipping them in a boiling solution of block tin and cream of tartar. Articles of wrought iron and steel are coated by first cleaning thoroughly; depositing on the surface a thin copper coat by electrolytic or blue vitriol solution; rinsing in water, drying and

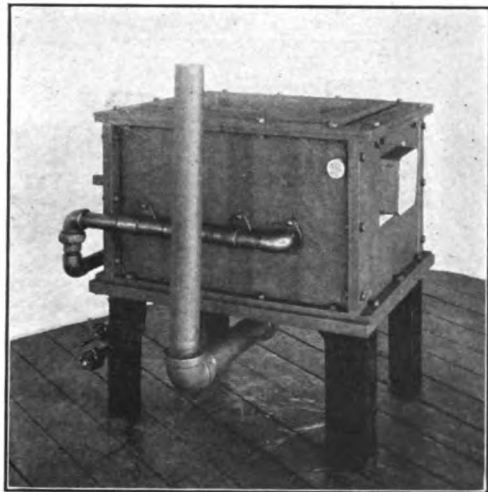

No. 10. Soft metal furnace used for tinning and galvanizing

dusting with powdered sal ammoniac; then dipping in a tinning bath which is covered with tallow. Finally, remove and swing or shake the piece violently to remove surplus tin, and dry in sawdust.

#### Galvanizing

Iron and steel when exposed to the action of the atmosphere without any surface coating will oxidize freely and a coating of rust will form. This is not only deteriorating in effect, but in most cases makes the metal unfit for use. Painting only partially overcomes this trouble as the paint soon deteriorates and the metal is exposed; besides every particle of the surface is not always covered.

Galvanizing forms a coating over iron or steel articles which preserves the metal against the oxidizing effect of the atmosphere. It consists in coating the surface of the metal with a thin covering of zinc. Galvanizing adds about one-sixth of a pound per square foot of surface to sheet metal when applied on one side only and, of course, double this amount must be allowed for when applied to both sides.

To galvanize steel, clean the surface thoroughly by boiling in caustic soda and dipping in sulphuric acid. When dry dip in a bath of molten zinc at a temperature of about 840 deg. F. and drain. The hotter the zinc the thinner the coating and the shorter the time for galvanizing.

Sheet iron is prepared for galvanizing by dipping it in a bath of 1 part muriatic acid to 4 parts of water. After all scale is removed redip in the same solution to which is added about 4 oz. of sal ammoniac to the gallon. When dry dip in molten zinc. Iron plate is prepared for galvanizing by cleaning in a mixture of dilute sulphuric and hydrochloric acids, rinsing, drying, glazing, cold rolling, again dipping and finally rinsing. After this, it is treated with a solution composed of 50 parts hydrochloric acid, 3 parts chloride of zinc,  $1\frac{1}{2}$  parts chloride of ammonia and 50 parts water. When dry it is immersed in the bath

of molten zinc. The zinc bath should be covered with sal ammoniac to prevent oxidation, an important detail.

New galvanized surfaces will not take paint unless treated with a coat consisting of 1 part each of copper chloride, copper nitrate and sal ammoniac dissolved in 64 parts water to which has been added 1 part commercial hydrochloric acid.

Cold galvanizing is accomplished by an electrolytic bath containing a 10 per cent solution of crystalline zinc sulphate. This bath is kept neutral or slightly acid.

#### Dry Galvanizing or Sherardizing

This method has come into commercial use extensively in recent years because of its many advantages over other protective coatings. The method consists in producing a zinc vapor within a closed retort and causing it to unite with the iron under the action of heat.

The metal to be treated is placed in a retort containing zinc dust. The retort is sealed and heated to a temperature of from 500 to 700 deg. F., depending upon the character of the work. The retort is either turned intermittently or rotated back and forth slowly so that all the parts are subjected alike to the zinc vapor.

In this process the zinc dust is vaporized under the influence of the heat; while in this state there is formed on the surface of the iron a layer of zinc-iron alloy together with an outer coating of zinc which gives additional protection. After the work has remained in the retort for several hours, depending on the thickness of the material, the retorts are opened and the metal allowed to cool.

This method of coating metals is not only economical but furnishes a superior finish. Its economy over other methods is evident by the low heat required as against a temperature of 840 deg. F. used in dip galvanizing. The coating is much thinner, therefore much less zinc is required. A coating of  $\frac{1}{2}$  oz. per sq. ft. is equal to or better than three times that weight in dip galvanizing. The

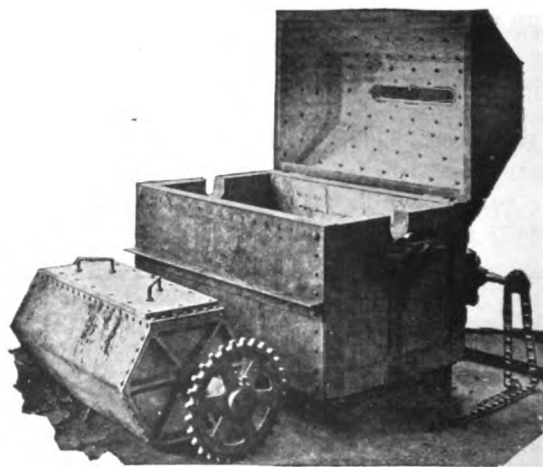

Sherardizing Furnace

superiority of sherardizing over other coatings is due to the fact that a more durable and even coating is formed as it is so driven into the metal that it does not materially change the exterior surface of the article. It may be applied to fine pitch screws and other accurately finished parts without the necessity of refinishing them.

#### Electroplating

Electroplating consists in coating metals with a deposit of gold, silver, copper, nickel or other metal by means of an electrolytic process. Surfaces to be electroplated must

be thoroughly scoured, polished and all grease and dirt removed by washing in a hot alkali solution and rinsing in clean hot water. The articles to be plated are dipped in a chemical solution suitable for the metal to be treated and are then suspended in a tank containing some of the metal to be deposited. The metal to be coated known in this process as the cathode is connected by a low voltage electrical circuit to the plates of the metal to be deposited called the anode. After the required amount of deposit has taken place the material is removed and cleaned in clear water.

#### Calorizing

This process consists of producing an alloy of aluminum on the surface of metals to prevent their oxidation when exposed to the atmosphere at temperatures above a red heat. The process is particularly useful in the treatment of iron and steel.

Pieces to be calorized are packed in a mixture containing powdered aluminum and aluminum with 1 per cent of ammonium chloride. The proportion of aluminum varies from 5 to 50 per cent by weight, depending upon the service to which the piece is put.

The operation consists in packing the parts to be calorized in the above mixture within a gas-tight box that is filled with a reducing or inert gas to prevent burning of the aluminum, then heated slowly to a temperature of from 1,300 to 1,750 deg. F. The time of firing depends upon the depth of coating required, but is usually about two or three hours. The process is useful in preserving the surface of boxes for case hardening and other uses.

#### Gas Heat-Treating Furnaces for Axles

In a paper on "Producer Gas and Its Industrial Uses," read before the Society of Detroit Chemists, a local section of the American Chemical Society, F. W. Steere, president of the Steere Engineering Co., Detroit, illustrated the possibilities of producer gas firing for heat treating front axles by the use of a set of furnaces which his company built for the Ford Motor Co., Detroit, as follows:

"Three heat treatments are required. After the first heating, the axles are allowed to cool in air by radiation. After the second heating, they are quenched. After which, they are again heated to a lower temperature and allowed to air cool. These furnaces are so designed and laid out that the axles are pushed mechanically through the first furnace and kept moving for a space of about 10 ft., until they reach a temperature within 50 deg. of room temperature. They are then mechanically fed into the second furnace, pushed through and quenched. A conveyor carries them from the quenching tank to the feeding mechanism of the third furnace, where they receive their final heating and are pushed out the rear end ready for the machine operations.

"It will be noted that the axles are handled mechanically throughout the process, and after being fed into the first furnace, do not stop until the three heat-treating operations are complete. These three furnaces have a capacity of completely heating one front axle per minute. Although the heats are different in each furnace, the three furnaces are duplicates, with the exception of the draft and damper settings to bring about the required temperatures.

"The hearth is 5 ft. wide by 14 ft. long. The axles are placed on specially designed cast-iron ways with the forks

hanging down. When the furnace is filled with these axles, the axles themselves form a practically solid floor which moves along through the furnace over the ways. Small pieces, such as cam shafts, spiders, spindles, etc., are piled on top of the axle and are carried through the furnace, receiving exactly the same heat treatment as the axles. These small parts are handled by hand between each furnace, as no mechanism has, so far, been designed to handle them mechanically. The gas and air are delivered through the reversing valves to the regenerators at a pressure of approximately 3 in. of water. The four regenerators are placed directly under the hearth, the gas on the inside and the air on the outside. There is one combustion chamber immediately over each pair of regenerators and immediately under one-half of the hearth and extending under its entire length.

"The products of combustion pass through flues along the sides of the hearth, sweep over the hearth, down through the flues on the opposite sides, divide after passing through the opposite combustion chamber, and pass down through the opposite pair of regenerators, through the reversing valves and out the stack. The furnace is reversed on an average of every 15 to 20 minutes. The products of combustion, while passing over the hearth, are directed by a series of jack arches placed every two feet at right angles to the movement of material over the furnace hearth. A solid division wall, built from the foundation to the hearth, separates the two pairs of regenerators. The furnace is inclosed in a steel jacket with  $2\frac{1}{2}$  in. of insulating material between steel and brick work.

"We have built this type of furnace with a muffle to prevent the products of combustion from coming in contact with the steel, the idea of the muffle being to reduce the scaling to a minimum. The average gas consumption with the muffle was 264 cu. ft. of gas per minute, the average cubic feet of gas per ton of stock being 22,970. The efficiency of the furnace was 14½ per cent.

"With the same type of furnace, running under exactly the same temperature conditions and delivering the same amount of stock, without the muffle, that is, the products of combustion coming in contact with the steel, we find that the average gas consumption was 73 cu. ft. of gas per minute, or 11,500 cu. ft. of gas per ton of stock, with a furnace efficiency of 26 per cent as compared with 14½ per cent as stated above. By furnace efficiency is meant the total amount of heat put into the stock, divided by the total amount of heat delivered to the furnace in the gas.

"From these comparisons, the cost of operating is very much greater when the muffle is used and the practical results on this kind of stock, with skillful operation, are about the same in both cases. We find that the temperature of the stock heated in the furnace can easily be kept within a variation of 10 or 15 deg. By skillful operation there is no difficulty in keeping the temperature variation within 5 deg. These results have been obtained over tests of several months' duration. The Ford Motor Co. is adding six additional front axle heat-treating units of the Steere Engineering Co. design, which will probably be in operation by the first of July."

Included in the various buildings being erected at the River Rouge by Henry Ford will be a very large unit devoted to tire manufacturing. Tires made in this factory will be manufactured exclusively for Ford cars.



## Bonus Payments in Making Dies

The bonus system as applied to die sinking was the subject of a paper by A. A. Motherwell, Buick Motor Co., Flint, Mich., at the convention of the American Drop Forge Association, held in Cleveland recently. The die bonus system, he explained, is a method of placing all die work and machine work on a piece-work basis, thereby putting it up to the worker to do his very best in the work for his own interest. When the system was first worked out the efficiency and cost departments in conjunction made a search of old records to arrive at the average time spent on all jobs when they were working on a day-work basis.

In setting the standard time for jobs about 50 to 60 per cent of the day-work average was taken. For instance, on connecting rods, the average time consumed on each set of dies on a day-work basis was about 140 hours. In setting standard time on the job we used 75 hours or a little more than one-half of the former average time. On connecting rods we therefore have a standard time of 75 hours per set for all work on the impression, edges and fuller. If a die sinker attains 75 hours in sinking a set of these dies he has attained 100 per cent of efficiency and is paid 20 per cent bonus. The money value of each set is, therefore, equivalent to the day-work amount of the worker plus 20 per cent.

For example, on connecting rods with 75 hours set for the time, the job is worth to a 60 cent per hour die sinker 75 hours at 60 cents (or \$45) plus 20 per cent, or a total of \$54. Now if a die sinker finishes a set of connecting rod dies in 40 hours he has been paid \$24 in day work while doing this work, so he has \$30 in bonus due, as the job pays him \$54.

Again, if a die sinker does it in 75 hours, the exact time given, he will get a bonus of 20 per cent for attaining this figure, or a bonus of \$9. Therefore, a die sinker will always get \$54 for one set of these dies, including the day rate paid him for his actual work. It is, therefore, evident that he will make a special effort to finish a set of dies as soon as possible to attain a good hourly average for his payroll.

The bonus system has worked advantageously with us. One set of axles was finished completely in 49½ hours for which we paid \$108 in day rate and bonus. When the job was done on a day-work basis it averaged 340 hours and cost \$204. Jobs are being done in one-fifth the time formerly consumed and the die sinkers are still maintaining a high quality of workmanship, as the work is checked up closely and no flaws of any sort or careless finishings are passed. All classes of die work are on the same sort of basis, including planing, cherrying, trimmer and punch work, and we are even carrying it out with small repair work. Since the introduction of the bonus system the efficiency of the die shop as far as production is concerned has increased about 300 per cent, and the men are satisfied and strive to make the jobs as quickly as possible, as no cut is probable in the standard time as set.

Mr. Motherwell emphasized that die sinking has always been a bugaboo. Often plants are out of dies and hammers, and therefore idle. Something has to be done to have the dies waiting on the hammers, instead of the hammers waiting on the dies. He raised the wages several times and finally put the die sinkers on the piece-work bonus system, and finds that the men are satisfied, and

he has no trouble in getting help. A production board is maintained and the work is taken out in regular order so that no favoritism is shown. During the past few months die sinkers have averaged \$1.05 an hour. At first under the system some bad work was done, but this has been eliminated by inspection. Work is not paid for until approved by the department.

George Desautels, Imperial Drop Forge Co., doubted whether a premium system could work in the jobbing shop, unless the same product is being made over and over again, and did not think it fair to put the jobbing shop against the big production shop. Mr. Horne said that the premium system had been working successfully for a year in the die sinking department of the Packard plant. Exceptionally good men get exorbitant wages, which the company was glad to pay as the men were earning them. Mr. Motherwell declared that the time is coming when the bonus system will be a back number and every employe will be one of the stockholders in the company. He believed that the bonus system could be worked out as well in a little shop as in a large shop. He stated that 95 per cent of the work done in the Buick plant is on the piece-work basis, this including men who handle steel and cut steel and handle scrap. He wished that the remaining 5 per cent could be put on piece work.

## Adjustable Suspension Device

A suspension device which is adjustable to varying loads has been patented in England by M. P. J. Van Geert, of Birmingham. Its principal object is to arrange for facile adjustment of the resistance of the springs on a road vehicle. Various arrangements are described, but the drawing here reproduced shows one which is especially applicable to a motor vehicle.

The suspension in this case consists of a pair of levers, one at each side of the chassis, one-half of each lever is rigid, the other half is flexible and may be formed in the same manner as a laminated spring. The pivot of the lever occurs at the juncture of the flexible and rigid por-

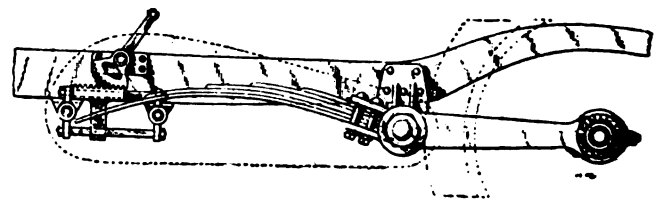

tions. The axle is attached to the free end of the rigid portion; the opposite end, or the free end of the flexible portion, is held between guides, which permit of motion in a horizontal direction, but not in a vertical one. By adjusting the position of these guides horizontally, the stiffness of the spring is affected.

The illustration shows one method whereby it is proposed easily to effect this adjustment; others are illustrated and described. It will be gathered that, as applied to the rear axle of a power-driven vehicle, such as a motor car or truck of the usual type, the two rigid portions of the levers may serve as radius rods. In such a case, spherical bearings would be of advantage, so that no opposition would be afforded to one wheel rising higher than the other one. Such provision is covered by the patentee in his specification.



War Department Drawings for Transport Bodies

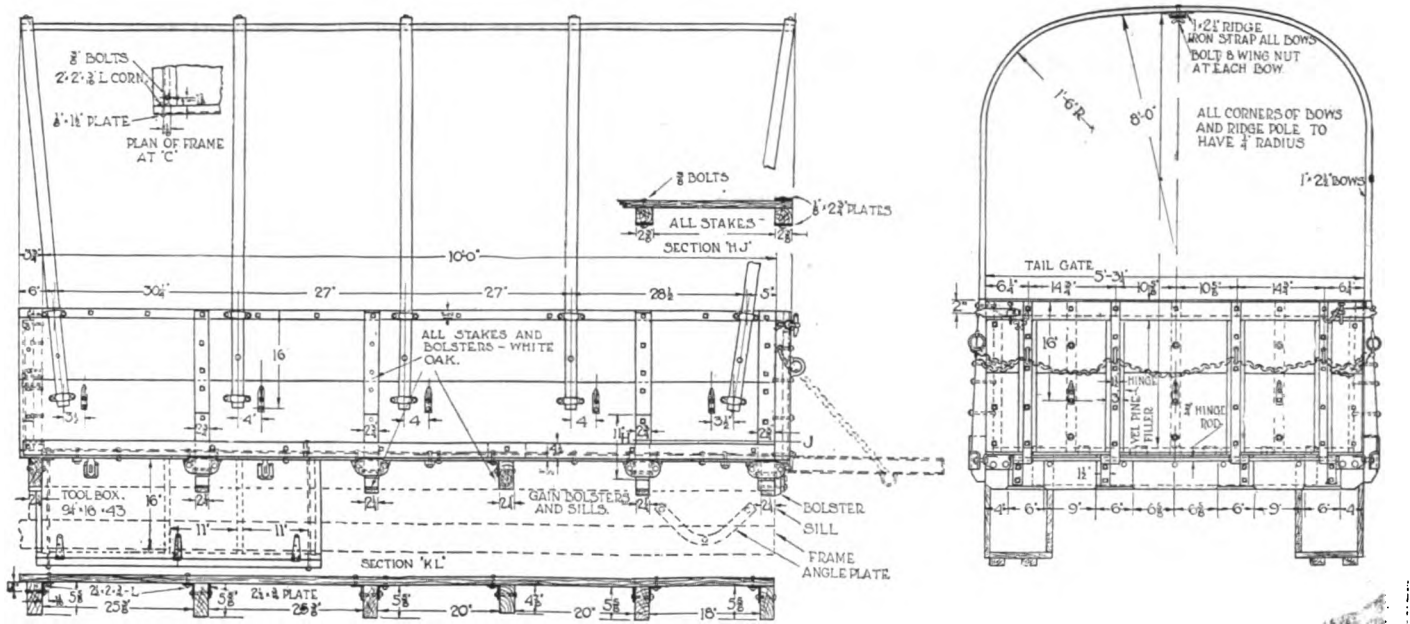

CLASS A MILITARY TRUCK

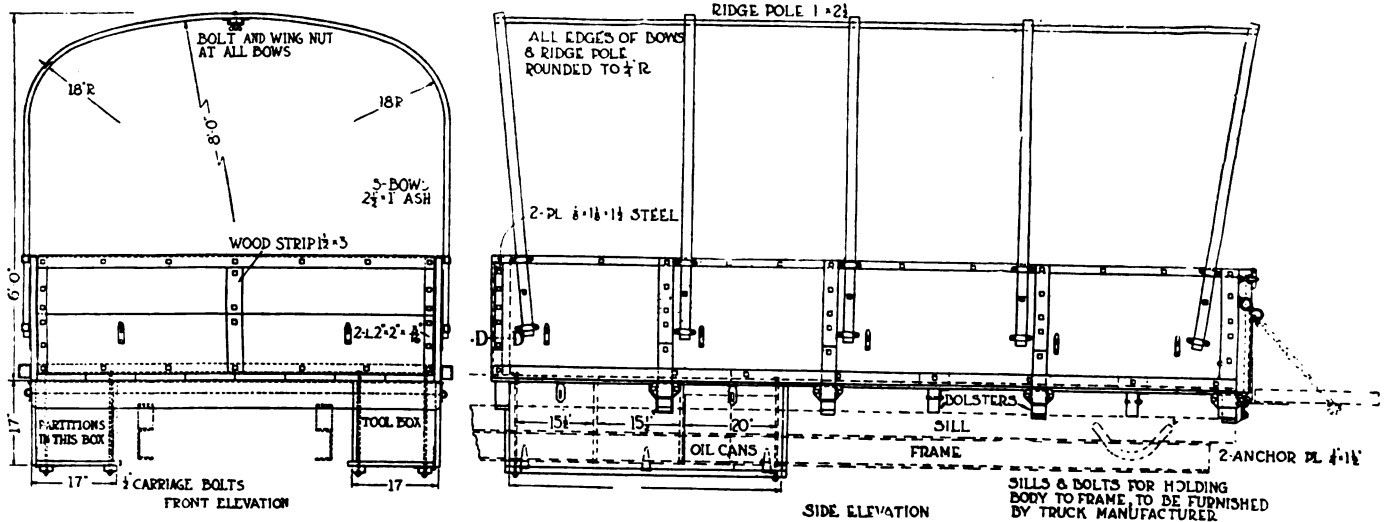

CLASS B MILITARY TRUCK

Carriage Manufacture in Guatemala

All kinds of vehicles from the oxcart to the limousine may be seen daily on the streets of Guatemala City. The country can exhibit some very stylish turnouts, and imported horses are constantly improving the domestic strain. Last year an American imported a number of Kentucky stallions, selling them at prices ranging from \$1,400 to \$1,600.

Guatemala City has four factories for the making of carriages and wagons, with an aggregate output of less than 100 vehicles per year. The customs record shows no separate importation of carriages or other vehicles for the year 1915. Under the classifications of "Accessories for vehicles" the customs record for that year shows a total importation of \$14,714 United States gold, of which \$11,054 represents the importation from the United States, \$3,389 from Germany, and the item of \$170 from Holland.

All the articles entering into carriage and wagon manufacture in Guatemala City, including spokes, rims, tires, springs, shafts, poles, harness, etc., are imported at this time chiefly from New York. Steel tires and steel axles are imported chiefly from Pennsylvania. A considerable quantity of hickory in the rough is also imported from the United States. About the only material supplied by Guatemala used in carriage making is mahogany, used for making carriage bodies, and a species of native hard wood known as "Guachipilin," used somewhat as a substitute for hickory.

Local manufacturers report a sharp decline in the demand for carriages and wagons within the past few years, due to the financial depression in Guatemala.

An ordinary surrey made in Guatemala retails at from \$250 to \$300 U. S. gold. Cabriolets and the better classes of carriages sell at from \$400 to \$750. Guatemala farm

wagons sell at from \$250 to \$300. Notwithstanding the lack of smooth-paved streets in Guatemala City, the local vehicles are so well constructed that they are said to last often from 20 to 25 years.

### Efficient Wagon Makers' Organization

Recently the wagon department of the National Implementation and Vehicle Association was signally recognized by the government because of the efficiency of that organization, which represents a large majority of wagon manufacturers throughout the country.

In an effort to secure the allotment to manufacturers of over 30,000 army transport wagons and over 70,000 motor bodies, as well as a vast volume of accessories, the wagon organization was the instrument used to bring together the manufacturers of the country in these lines in conference, so that a clear understanding of the specifications and conditions might be had. This was accomplished so successfully that the allotment of orders was made satisfactorily to both the government and the manufacturers.

The magnitude of this business may be realized through the fact that in the manufacture of the motor bodies alone approximately 20,000 tons of iron and steel and 37,000,000 feet of lumber will be used.

The advantages of industrial organization are fittingly illustrated in this circumstance, which enabled these manufacturers to respond so effectively to the government's call.

The association is now endeavoring to co-ordinate its work with the efforts of the government to increase and conserve food supplies in which agricultural implements and farm operating equipment are such important factors.

### New Radiator Center

An invention, the object of which is to improve the construction of the vertical tube type of radiator, has been

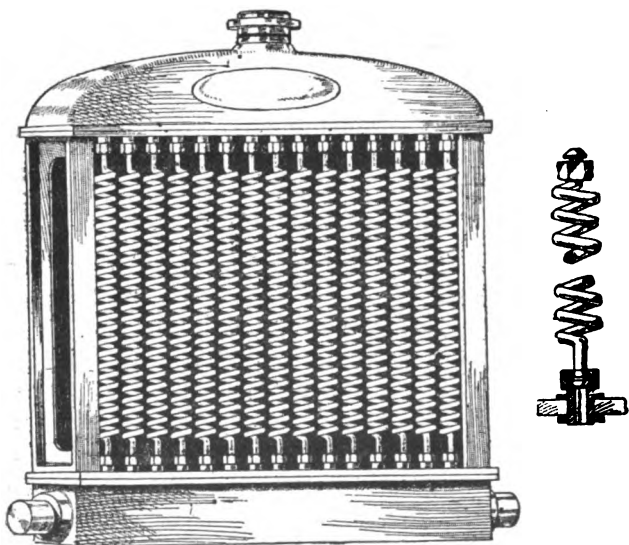

patented in England by Mechanist Sergeant-Major W. F. S. Harding, M.T., A.S.C.

The novelty of this device consists of the utilization of helical coil tubes instead of the plain or straight ones; moreover, the tube is secured in the tube plates, both top and bottom, by means of the ordinary type of union nipple.

Any of the front tubes which may be damaged as the result of accident can be removed and replaced in a few

minutes, and if renewals are not at the moment available, it is an easy matter to close up the end of that portion of the union left in the tube plate by means of a rubber or fibre washer held in place by the union nut. If any of the inner tubes are damaged as a result of frost, they are accessible merely by removing two or three of the tubes in front of them, and they can be renewed or the holes stopped in the same manner. The removal and replacement of the front row of tubes is simple and can be accomplished rapidly.

These are the advantages claimed for this type of radiator in connection with the affecting of repairs. It is also claimed that a tube of the form shown presents much more cooling surface to the air, and, in consequence, the number of tubes may be considerably reduced, the expense of fitting likewise decreased, and since the size of the top and bottom headers and the width of the side plates depend upon the number of tubes these can be reduced accordingly, and a saving effected in the overall weight of the radiator and the water carried. As a result of the cooling of the tubes in the manner shown, it is said they are considerably less likely to suffer from the effects of vibration, a slight shock is not likely to cause a breakage, as the tubes will give, and any deleterious effects of vibration of the chassis will be lessened because of the springiness of this form of construction.

### C. E. Adams on After-War Competition

Charles E. Adams, of the Cleveland Hardware Co., sounded a note of warning as to conditions when the war is over, in an address before the American Drop Forge Association convention held in Cleveland in June. When all plants are endeavoring to get production it is the time for manufacturers, with a view to the future, he said, to work out the best and most economical way of doing things. He predicted that manufacturers will face the same conditions as existed before the war, and possibly worse conditions. He spoke of being offered \$38 per ton for steel scrap that he had formerly sold as low as \$8 and said that he would not be surprised to see the price drop back as low as \$7 a ton. At present about 15,000,000 men are engaged in the war and much of their work at home is being done by women and boys. These 15,000,000 men will be looking for jobs as soon as the war is over. Manufacturers should plan economical ways of doing things by cheapening labor, not by paying labor less per hour, but by getting from one man and the machinery as much output as two or three men are turning out now. He did not believe in placing a stone wall around a manufacturing plant so that competitors could not ascertain how work is being done and announced that his plant was open to the inspection of everybody interested.

### Ralph D. Mock an American Motors Director

Ralph D. Mock, treasurer of the Hydraulic Pressed Steel Co., Cleveland, O., has been elected a director of the American Motors Corp., Plainfield, N. J. Louis Chevrolet, vice-president of the company, reports that cars are being turned out at the rate of four a day and that business is good with the distributors. The company is developing a two-passenger sporting body in addition to the four-passenger roadster which is now ready, and is prepared to supply cars in all colors, white excepted, up to September 1.

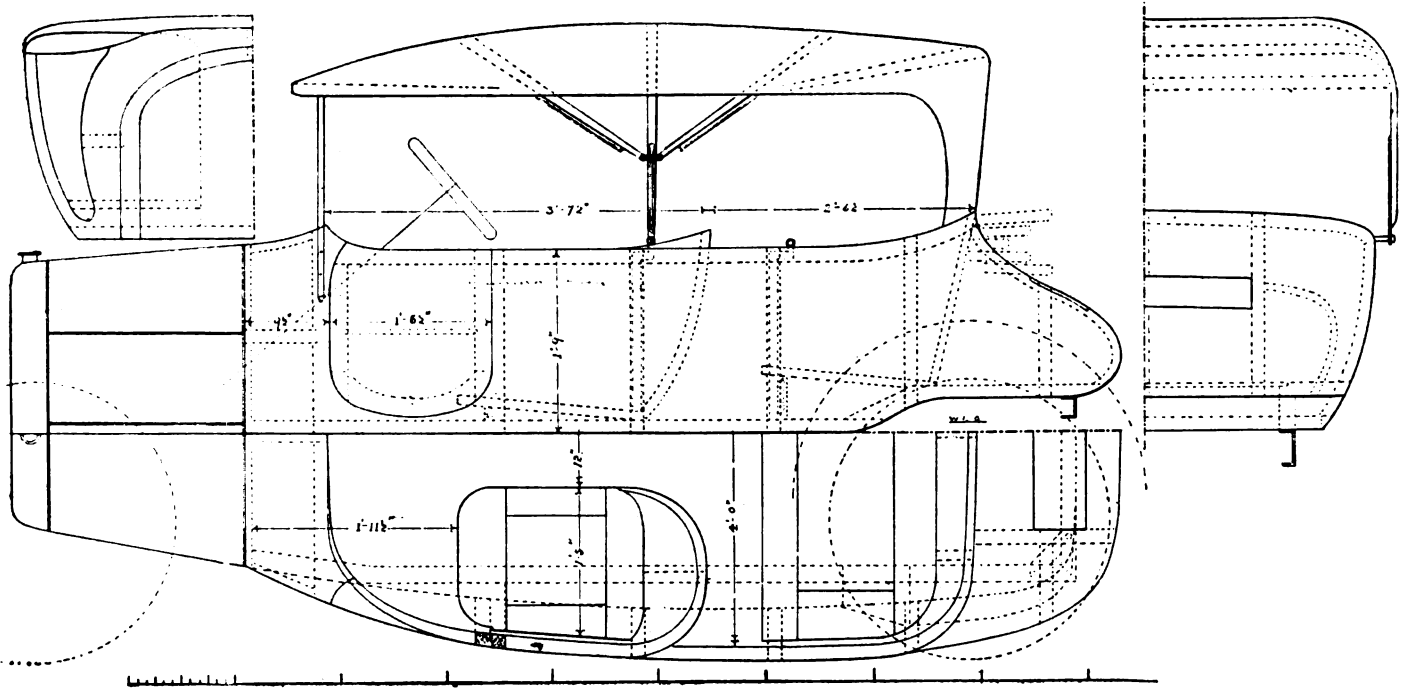

### Double Seater Body

The double-seater body shown on this page is spaced off to give seating accommodation for four passengers, and a boot at the back for small parcels, etc. The construction is simple, and should be made as light as possible, for this style of body is mounted on a small chassis. The one shown has a body space of 7 ft. 9½ in.

The bottom side rails are cut to suit the up-rise of the chassis, and are beveled to suit the layout of the side pillars. This bevel is shown in side elevation. As there is a passage between the front seats, a cross-bar is advisable to hold the body together, and this bar is fitted to suit the access to gear box on the chassis.

The back cross-bar is fitted and cut to suit the round back of the boot, and the pillars are cut to the pattern shown in side elevation, and the doorway pillar checked to hold the door. The top rails are cut and shaped as shown in plan. The top cross rails are fitted and the elbow corners. The boot is made up by fitting two rails from back top cross rail to the back cross-bar. The rails are spliced and dressed to the shape required. A cross rail is fitted on each side in alignment with the side pillars rounded off to suit the top shape of boot. Two cross battens fitted between center rails make the door opening. The front seats are separate, and are built to suit the steering position. Revolving chair seats are very suitable, for then passengers can face in which direction they choose. The scuttle dash is next built on, and the door rockers fitted. The doors are made and fitted, and the framing dressed off ready for paneling.

A good way to fasten the panels is to beat them over the edge, top and bottom, and if neatly done, the need for molding is done away with. The hood is simple and effective. The sticks are all worked off the center one, and they work up and down on a slide rail, similar to the peak. The back of the hood is worked in the same way, and when folded down, is lifted out and put into a socket fitted to receive it, a suitable distance from the back, thus making it very compact when folded. The screen is a matter of taste, and any pattern can be adopted. The

panels being on, all joints are sweated, and the first coat of paint is put on.—Australian Coachbuilder and Wheelwright.

### Text Book for Commercial Body Work

A new text book dealing with the construction of all types of bodies for business purposes entitled, "Motor Body Work for Commercial Cars," has been issued by Cooper's Vehicle Journal, Ltd., 19 Garrick street, Long Acre, London, W.C. The author of the book, C. W. Terry, chief designer of the aforementioned publication, is well qualified to appreciate the needs of the apprentice and student, for his work as inspector of all technical carriage and body building classes organized throughout the kingdom under the City and Guilds of London Institute has given him unique qualifications in this direction, not to overlook the advantages of the splendid organization of the Cooper's Vehicle Journal.

The book contains working drawings, diagrams and sketches, as well as a glossary of technical terms. It can be secured by addressing as above upon the remittance of \$1.56, which includes postage.

### Tire Makers to Form Association

A division of the Rubber Association of America is being organized by tire makers. This move was approved at a recent meeting of most of the principal tire makers. The new division will be similar in organization and purpose to the other existing divisions of the association. It will take up the problems of the tire maker with a view to solving them in a manner acceptable to all. At the meeting it was also decided to adopt a standard contract cause covering fluctuations in tire prices, which provides that if a maker finds it possible to reduce the price to the dealer he will give the dealer the benefit of the reduction, and if the maker increases the price the dealer is to have the choice of accepting the balance of unfilled contracts at the advanced rates or of cancelling the balance of the contract.

## "Electric" Makes Long Run in Record Time

That the electric automobile is admirably adapted for long runs has just been proven by an inter-city run made from Atlantic City to New York City on Tuesday, June 19, under the auspices of the New York Electric Vehicle Association. The run is a blow to old traditions about the electric passenger car being favorable for only short trips. Its performance compared creditably with the best performances of gasoline-driven cars over the same route. It is even doubtful if a greater speed than was accomplished by this electric would be demanded by the average motorist, and it is certain that a greater speed would not be legal. The run was made in a Baker, R. & L. stock car, model Bx 7, which is a new model and which this run practically introduces to the public. The features of this model are that it is lower hung, offering consequently less wind resistance and increased battery space.

The car left New York on Monday morning, June 18, driven by Edward Smith of the Baker R. & L. Co., with Waldo W. Sellow, a passenger, as official observer for the New York Electric Vehicle Association. The trip to Atlantic City, which was chiefly to investigate road conditions, was made in the comfortable time of less than eight hours, no special effort being made to make a record in speed, the plan being to make the speed effort on the return trip.

The run from Atlantic City to New York was made in five hours and 58 minutes actual running time, with a boost of 1½ hours at Lakewood. The mileage covered by the car from Atlantic City to New York was 123½ miles, making the average running time 20½ miles per hour. The entire distance was covered with the car running at fifth and sixth speed. It is claimed that the current used to drive the car from Atlantic City to New York cost less than half the price of enough gasoline to drive a gas car over the same route. 283 ampere hours were used in the run, an average of 2.29 per mile, the cost of which at a five cent kilowatt hour rate, which is the maximum charging rate in New York City, would make the cost \$1.55.

---

## Annual Meeting of Vehicle League

Twelve members were represented personally and two by proxy at the annual meeting of the Vehicle League, the southern association of vehicle manufacturers, held at Greensboro, N. C., May 23. A portion of President Hackney's annual address is as follows:

"During the past year our business has been exceptionally good, better than we expected, being from 60 to 70 per cent of normal. We could have increased our sales very near normal by accepting certain orders from dealers who wanted the same old price—but our old price is gone never to return, and the manufacturer who has not advanced his price from 12 per cent on up can look for a loss at inventory time, and it is going to be a long, long time before prices ever get back again, if they ever do."

The governing board recommended the election of new officers for the ensuing year, and the following were unanimously elected: President, W. B. Waddill; vice-president, P. P. Hunter; secretary and treasurer, C. P. Heindel  
Board of governors: W. B. Waddill, P. P. Hunter, H. A. White, A. L. Black, B. F. Taylor, F. H. Delker, T. J. Hackney, W. G. Norman.

The commissioner was instructed to mail the following

letter to all dealers, as members present stated that the dealers need exactly such an influence as the league exerts in order to keep accounts paid up promptly:

"The regular annual meeting of the Vehicle League was held May 23 at Greensboro, at which meeting the improved business methods of the vehicle dealers were especially commented upon, and in order to convey the appreciation of the manufacturers to the dealers, the following resolution was adopted:

"Resolved, That the Vehicle League, comprising buggy, wagon and saddle manufacturers, in meeting assembled, hereby pass a resolution expressing their appreciation of the co-operation of the vehicle dealers in the shortening of terms and the noticeable improvement in their business methods, as our accounts have been paid more promptly according to terms and contract than ever before, and it is evident that the dealers are realizing the fact that materials are purchased by the manufacturers on a cash basis—10 to 30 days, with no past dating—and that long dating is now a thing of the past.

"Trade abuses are few and far between, as the majority of complaints brought to a dealer's attention are now known to be not the fault of the manufacturers but rather the careless misuse of the vehicle by the user.

"The vehicle manufacturers are cognizant of the very evident and noticeable improvement in the dealers' business methods, and desire to express our appreciation to each dealer personally."

Commissioner was instructed to write former president George Hackney conveying the league's appreciation for his faithful service to the association.

A full and free discussion was entered into by all members on the subject of costs and terms, which developed the fact that old-time long dating is now a thing of the past, most members stating that as their supplies, etc., must now be bought on 10 and 30-day terms, they have reduced selling terms to 30 and 60 days, eliminating dating entirely.

The value of the league's service was favorably mentioned.

---

## Electric Transportation for Explosives

A truck for the transportation of explosives must be as nearly fireproof and collision-proof as is possible to make it, and the electric vehicle is therefore particularly adaptable because of its lack of fire danger, and its fixed maximum speed and easy control which lessen the chance of collision.

To meet the strict specifications the body of the truck must be very carefully constructed—a heavy steel frame entirely lined with wood in such a way that absolutely no metal is exposed, then all parts thoroughly covered with fireproof lining, including every wire and even the control. Special designed shock absorbers and patent bumpers are attached, and four fire extinguishers must be carried for any emergency.

The smooth running and easily managed "electric" readily negotiates congested traffic, and seems to possess all the necessary features for transportation of this type. These electric trucks are used in New York City by a large manufacturer of explosives, and are accepted by the Bureau of Combustibles of the New York Fire Department as the safest means of transporting explosives through the city streets.

### Body Design for An Ice Wagon

The design is for a wagon body shown in the illustration that can be used to carry ice, and is constructed according to the design of the ice wagons used in cities. The length of this body outside of the corner posts is 9 ft. 4 in. The width outside of top rail is 52 in. The

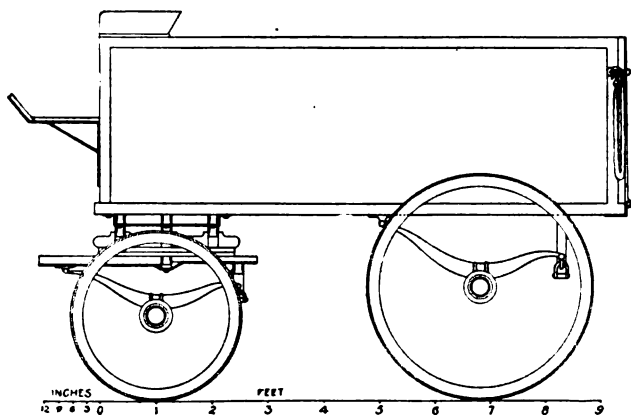

Fig. 1

extreme height of the sides of the body is 3 ft. The size of the sills is  $1\frac{7}{8} \times 4$  in. with cross bars framed into them, but they are not all of the same thickness, nor of the same widths. The front cross bar is  $1\frac{7}{8} \times 5$  in. wide, mortised into the sills, level top and bottom. The bottom cross bars, which are directly above the spring bar, are also

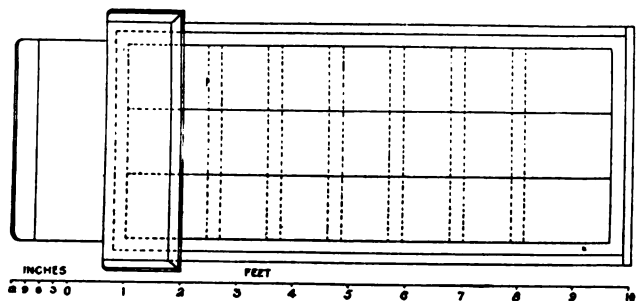

Fig. 2

level with the bottom surface of the rocker. The two in front and two in the rear of the spring bar are  $\frac{3}{8}$  in. below the bottom surface of the rocker, making a cross bar  $1\frac{5}{8}$  in. thick. The reason for this is on account of the wide body, which weakens the cross bar. The rear spring bar is used for a cross bar and therefore must be

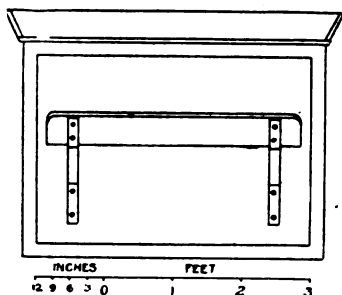

Fig. 3

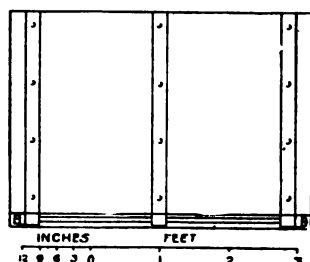

Fig. 4

notched in  $\frac{5}{8}$  in. below the top surface of the sills, if the bottom boards are  $\frac{5}{8}$  in. thick. The rear end cross bar is  $1\frac{7}{8} \times 5$  in., lapping over the bottom surface of the sill  $\frac{1}{4}$  in. The front posts are  $2\frac{1}{8} \times 3\frac{1}{8}$  in. The rear corner posts are of the same size. The panel sides are  $\frac{3}{4}$  in.,

rabbeted and grooved into the sills and strengthened with strap bolts. There are six bottom cross bars,  $4 \times 2\frac{1}{2}$  in. Fig. 1 is a side view. Fig. 2 is a plan view showing cross bars and the general construction of the flooring. Fig. 3 is a front view. Fig. 4 is a rear view. This style of ice wagon is generally covered with a piece of canvas after the ice is loaded in, to prevent the ice from melting. The seat is low so that the driver, if he should care to, can easily spring to the seat from the inside of the body instead of climbing up on the wheels.—Blacksmith and Wheelwright.

### The Motor Industry in the United States

There are in the United States 450 automobile and motor truck plants, and 825 body, parts and accessory plants. Automobile and truck dealers number 25,924, and garages 23,868. There are 12,171 automobile machine shops and 2,500 exclusive automobile supply houses. It is estimated that there are 915,000 wage earners in the automobile industry in the United States.

During 1916, 1,493,000 passenger cars were manufactured and 90,576 commercial vehicles. The average wholesale value of passenger cars produced in 1916 was \$575. On December 1, 1916, there were registered motor vehicles to the number of 3,541,738, of which it is estimated that 40 per cent are owned by farmers. In Iowa there is a car to every 13 individuals.

The total registration and other fees paid by motor owners last year amounted to \$28,889,167. The 12 largest companies produced in 1916 80 per cent of the total output of cars, 438 concerns producing 20 per cent between them. Passenger cars to the number of 61,941 were exported, and trucks to the number of 18,903, a total export value of \$96,595,861.

In the last five years 718 companies in the motor vehicle business have gone out of business. The average per cent of profit made by automobile manufacturers during 1916 was 12 per cent, and the percentage of advertising appropriation to the total sales was 2 per cent.

In the last two years the cost of labor has advanced 25 per cent, and the cost of materials from 30 to 400 per cent, dependent on the type of material. Automobile plants are now located in 32 states.

### The Electric Taxicab

The most recent installation of electric taxicabs, which have met with phenomenal success in Detroit, is in St. Louis, where six cars make up the nucleus of a fleet. The clean, silent, smooth running attractive electric taxicab has made a strong and immediate appeal, and has proven itself to be extremely well fitted for this service, especially because of its low operating cost, and its simplicity of operation through congested streets, insuring safety to its occupants. The mileage of these electrics is practically unlimited, as facilities for "boosting" are situated in various parts of the city, so that the cab may be charged while it is waiting, even though it may be only a few minutes.

An electric taxicab company is now being organized in Mexico City, is also in successful operation in Shanghai, China, where it has to a great extent replaced the quaint and quite inexpensive jinrickshaw.

Progress is being made in the matter of the initial fleet of about 500 electric taxicabs of the most advanced type, which it is intended to install in New York City.

## Large Increase in U. S. Motor Cars in New Zealand

The sale of motor cars, trucks, etc., in New Zealand has practically doubled during the past two years, and the 1917 outlook is promising, according to Consul General Alfred A. Winsow, for there is plenty of money in the country, and a largely increased number of machines is being made use of by the farmers and stock raisers in the Dominion. They are useful and economical, for they save much time, and time now means money to these people.

The increased imports of automobiles during the past three years by number and factory value are shown in statistics which include bodies and chassis separately for 1914 and jointly for 1916; but these give a very poor idea of the real cost to the consumer in this country, since one American five-passenger touring car sells at port of arrival for \$875; another five-passenger car of 35 h.p. at \$1,640; a five-passenger four-cylinder car at \$1,605; a six-cylinder car at \$2,116; a five-passenger eight-cylinder car at \$3,771; and so on through the list. The figures are:

Countries.	1914		1916		Complete motor car.	
	No.	Value.	No.	Value.	No.	Value.
United Kingdom..	921	\$311,802	1,094	\$1,225,010	228	\$321,550
Canada .....	872	127,381	881	359,722	1,630	681,344
Belgium .....	5	1,431	24	37,034	1	973
France .....	57	15,592	134	147,922	12	14,600
Germany .....	15	6,127	22	42,402	.....	.....
Italy .....	10	2,604	11	12,687	16	25,578
United States ....	1,247	352,743	1,308	986,255	4,286	2,903,291
All other .....	.....	.....	1	1,460	1	973
Total .....	3,127	\$17,680	3,475	2,812,492	6,174	3,948,318

American manufacturers have greatly increased their business here, while motor car imports from the United Kingdom have fallen off about 75 per cent, and those from Canada have increased.

Practically all of the motor cars have been of the internal combustion type, but electric for city use in the more important centers should find a fair opening, since the cost of benzine, gasoline, etc., is very high, and electricity comparatively reasonable. At Christchurch, current for power purposes sells at 1 to 2 cents per unit, while at Auckland it ranges from 2 to 2½ cents per unit. It would seem worth while to make an effort to open up this business for electric automobiles.

There should be a fairly good field here for motor trucks and motor delivery wagons. A few are in use now, but there ought to be room for many more.

Motor vehicles for road traffic, including motor cars and motor carriages, pay a duty of 10 per cent from the United Kingdom and possessions, and 20 per cent from all other countries; also a special war tax of 1 per cent which is collected on all imports.

### Will Survey Export Possibilities

The Bureau of Foreign and Domestic Commerce, Department of Commerce, will furnish automobile manufacturers with first hand information in regard to conditions governing the sale, use and demand for motor vehicles and allied lines in Russia and the Far East. These reports will be obtained by Tom O. Jones, who has been appointed trade commissioner to investigate conditions, and they will be published in the Daily Commerce reports.

His investigations in relation to industrial vehicles will cover the following subjects:

1. Sizes that will have the biggest demand.
2. Preference for bevel gear, worm, chain, or internal gear rear drive.

3. Demands for transmission as to location and number of speeds.
4. Climatic conditions regulating cooling.
5. Makes or types of carbureters and magnetos preferred.
6. Lighting requirements.
7. Type of tires demanded.
8. Demand for towing hooks, trailers, etc.
9. Facilities for building bodies.

Tractors:

1. What advance, if any, has been made in using tractors for farm work and the possibility of development as indicated by the size of farms and general conditions of ownership.

2. Road tractor possibilities in any contemplated development or in general hauling.

The survey will also include the possibilities of the sale of steam and electric vehicles.

Reports will also be made on tire equipment in most general use, classes of accessories in demand for replacement of original equipment of machines now in use and what will probably be required for future purchases. Fuel supply problems, customs, charges, and freight rates, and similar information will also be given careful study.

### Automobile Sales Reflect Holland's Prosperity

The automobile trade of Holland prospered during the past year. Representatives of American manufacturers enjoyed a record business in spite of difficulty in getting sufficient supplies of tires. Often a shipment of automobiles without tires would arrive from the United States, only to be stored away until tires arrived; even then long delays were frequently caused by the requirement of satisfactory guaranties that the tires would be used solely in Holland.

The automobile factory in Amsterdam (Trompenburg) was unable to obtain certain materials formerly imported from belligerent countries and Holland could not furnish them. Consequently several hundred partly built automobiles remain undeliverable to purchasers. This factory was hampered likewise in the manufacture of aeroplanes, of which it hopes to deliver a considerable number in 1917, with the aid of the Dutch Government in obtaining the required material.

The active demand for automobiles in 1916 was due to the generally increased wealth of all classes. Farmers bought automobiles for the first time.

### Receiver Disputes Enger's Notes

If disputed claims for \$160,000 are disallowed, the stockholders of the Enger Motor Co., Cincinnati, O., will receive the return of practically their whole investment. The real estate of the company has been sold for \$70,000, and other assets brought \$140,173. There is now a balance on hand of \$88,129, and \$21,188 in accounts receivable, cars, car parts and office fixtures. Of the disputed claims against the company, \$150,000 is in the form of notes signed by Frank J. Enger as president of the company, and held by three banks. Enger committed suicide last January, leaving minute directions for the continuance of the business. The receiver for the company claims that his notes should be charged against his personal estate, not against the company, and is now awaiting the decision of the court.



## Government Orders 10,550 Trucks

The chief of staff of the army on July 17 approved contracts submitted to him by the transportation branch quartermasters corps of the army for a total of 10,550 truck chassis as follows:

Packard Motor Car Co., 300 Class B chassis in accordance with schedule L and government specifications as modified by exceptions in Packard exhibit D; delivery to be 100 in August and 200 in September; price \$2,803.81 each.

Packard company, 1,500 Class B chassis in accordance with schedule N and government specifications as modified by Packard exhibit E; delivery to be 500 per month beginning with October; price \$3,197.37 each.

Locomobile company, 400 Class B chassis with electric light equipment, according to government specifications as modified by manufacturers' specifications; delivery to be 125 in October and a similar number each month until contract is completed; price \$4,224.57 each.

Four-Wheel-Drive Auto Co., 3,750 Class B chassis as per proposal No. 1 with the addition of rear bumpers and ordinance towing hooks at \$48 each, total, with bumpers and hooks, \$3,248; delivery to be 175 in August and an equal number each month until contract is completed.

Pierce-Arrow Motor Car Corp., 700 Class A in accordance with proposal No. 2, delivery in accordance with proposal \$3,500 each. Order to be increased to total of 800 on same terms if agreeable to the Pierce-Arrow corporation.

Nash Motors Co., 3,000 Jeffery Quad Class A chassis according to specifications as modified by bidder's proposal; delivery according to proposal, complete by July 1, 1918; price \$2,805 each.

Garford Motor Truck Co., 900 Class A chassis in accordance with exception by bidder; delivery as per proposal, completed by end of December, 1917; price \$2,730 each.

Motocycles, 3,500 Indians and 1,500 Harley-Davidsons, \$247.50 each, outside price.

All deliveries of truck chassis are f.o.b. factory, shipping instructions to follow later.

These orders go to makers able to deliver quantities around 1,000 or over. The vehicles are in almost every case standard commercial products plus a few details such as special gasoline tanks, extra wide seats, radiator guards and so on. There has been no announcement regarding the bodies which, without doubt, will be of all sorts, with the majority the regulation stake type most required for general purposes.

The four-wheel-drive machines are mainly for the ordinance department for work in connection with guns.

## A Very Serviceable Product

Certainly the motor car builder is most fortunate in being able to draw on the manufacturers of parts for some very intricate, and at times, difficult fitments. We have seen no more interesting development along such lines than the way metal is shaped under rolls. Some of it looks to be a puzzle for such treatment, but skill appears to have prevailed, at any rate in the mills of the Empire Art Metal Co., Inc., at College Point, N. Y. Some of their published announcements give a pictured idea of what we are trying to express, and it is a better effort than ours. The automobile furnishings such as running, foot and dash boards, wind shields, channels, and many special

shapes from builders' blue prints are worth attention, we think. What we have mentioned is but one branch of a varied industry that calls for thousands of rolls, yet the company is always ready to figure on blue-print specifications for a customer, with prompt deliveries assured.

## Still Considering German Patents

German patents so far have not had their status altered in any way by the United States; eventually, however, some arrangement probably will be made that will open them to American manufacturers. At present the Department of Justice is working on a measure that will define the position of German patents. According to all indications, it is probable that it will open the use of the patents to American firms on the payment of suitable royalties, which will be placed to the credit of the German owners. Thereby American users of the patented constructions will be able to secure necessary supplies, the owners of the rights protected, and Germany given no grounds for acting to the detriment of American owners of German patents. The automobile industry is the user of a number of German patented constructions, notably in the bearing field, some of which have been manufactured in this country since the war started, under royalty arrangements.

## Over 3,500,000 Motor Cars in U. S.

In 1916 there were 1,067,332 more motor cars registered in the United States than in 1915. This was an increase of 43 per cent. The gross total of registered cars, including commercial cars, was 3,512,996; the number of motor cycles registered was 250,820. The several states collected in registration and license fees, including those of chauffeurs and operators, a total gross revenue of \$25,865,369.75. Of this amount 92 per cent, or \$23,910,811, was applied directly to construction, improvement, or maintenance of the public roads in 43 states.

The figures for 1916 correspond very closely with the annual percentage increase of motor car registration of the last three years. This yearly increase has averaged 40 per cent in the number of cars and 50 per cent in revenues.

## Fifth Avenue Coach to Build Its Trucks

The Fifth Avenue Coach Co., New York, has been forced to manufacture its own trucks on account of war conditions. It has acquired property at 132d street and Broadway for the erection of a four-story plant for the manufacture of motor buses. The plant is estimated to cost about \$1,000,000.

The company has already assembled about 60 of its new trucks, and is planning to produce 200 in all, under its own specifications. The Moline-Knight engine will be continued with certain modifications.

Before the war started the company imported hundreds of buses from France, the majority of them being De Dions. Since then it has designed its own trucks.

## New York Show Dates January 5 to 12

January 5 to 12 are the dates for the 1918 New York National Automobile Show in the Grand Central Palace, announced by the National Automobile Chamber of Commerce.

### Trade in Motor Vehicles in Australia

Imports of automobiles and accessories from the United States into Australia during the past two years were as follows: Motor chassis, \$1,812,912 in 1915 and \$4,749,104 in 1916; motor car bodies, \$472,994 and \$1,521,141; motor-cycles, \$138,393 and \$588,705; and manufactures of rubber, \$832,735 and \$2,939,131.

The imports from the United States into New South Wales were: Motor chassis, \$712,791 in 1915 and \$1,965,695 in 1916; motor car bodies, \$175,374 and \$619,227; motor-cycles, \$19,684 and \$160,929; and manufactures of rubber, \$1,217,398 and \$2,012,560.

According to The Australian Motorist the demand is for low priced cars and the American manufacturers are getting the business. It is stated that there is not an American car in the Commonwealth costing more than \$2,554.

### Free Admission of Vehicles Into Mexico

The American charge d'affaires at Mexico City reports that there has been published in the local press a circular of the Mexican Treasury Department, dated June 29, 1917, permitting the free importation until December 31, 1917, of the vehicles specified in Nos. 624, 625 and 627-629 of the Mexican customs tariff. The items referred to include carts, wagons, motor trucks, and other vehicles of all kinds for commercial and agricultural use and for the transportation of goods, and carriages and automobiles for passenger use, the duties remitted varying from \$5.65 to \$16.94 per 100 pounds. A circular issued in March, 1917, exempted from duty motor vehicles other than pleasure cars imported during April, May and June of the present year. This later circular apparently extends the scope as well as the duration of the previous exemption, but this is subject to official confirmation.

### All Ambulance Assembly at Kentucky Wagon Plant

All motor ambulances hereafter bought for the United States army will be assembled at the Kentucky Wagon Mfg. Co., Louisville. The contract between the government and the Louisville concern covers a period of years and specifies several thousand cars per annum. The parts of the ambulances, made by many factories, will be shipped to Louisville for assembling. The work will require the employment of scores of expert mechanics, in addition to those already connected with the Kentucky Wagon Co.

### Morgan Potter Will Not Build Automobiles

The Morgan Potter Mfg. Co., Beacon, N. Y., which recently changed its name to the Morgan Potter Motor Co. to devote its plant to the manufacture of a four-cylinder five-passenger touring car, a light truck and truck converters, has decided to abandon all such plans. It will continue to make brakes for trucks.

### Studebaker Gives Color Options

The Studebaker Corp., South Bend, Ind., is now giving its purchasers of series 18 cars four options in colors and has a new top known as a gypsy top of semi-permanent type with the front part extended to cover the entire body of the car to the windshield. It is an evolution of the old victoria type.

### Robert Cartmell Moves Up

Robert Cartmell, who has made a splendid record in the Los Angeles branch of the Kelly-Springfield Tire Co., has been promoted to a more important post at the general sales offices of the company at Cleveland, where he has been placed in charge of the sales of solid truck tires. He now comes directly under the wing of General Sales Manager Otis R. Cook, through whom the appointment was made.

### N. I. V. A. Will Meet in Chicago

The executive committee of the National Implement and Vehicle Association consider it expedient to change the place of meeting for the annual convention this year, and in place of going to Atlantic City, as voted by the association at the convention last fall, the meeting will be held in Chicago. The convention will open Wednesday, October 17, and plans for all sessions will be announced later.

### Trailmobile in Cape Town

A short time ago the South African agent of an American trailmobile company held several exhibitions in Cape Town to demonstrate the practicability of the trailmobile for use in that country. The demonstration created considerable interest. The agent states that to date about 20 have been sold as a result of the exhibition and frequent advertising. Efforts are now being made to bring it before the farming communities of the Cape Province.

### Fisk Buys Gibney Tire

The assets of the Gibney Tire Rubber Co., Conshohocken, Pa., have been purchased by the Fisk Rubber Co. for \$408,187. The manufacture of solid tires will be continued to the fullest capacity of the plant and for the present as a branch factory of the Fisk company. The product will be marketed by the Fisk Rubber Co. of New York through its branch houses and through branches already established by the Gibney concern.

### Wisconsin Carriage Co. Changes Name

The Wisconsin Carriage Co., Janesville, Wis., well known manufacturers of fine carriages and vehicles, has changed its name to Janesville Products Co. and increased its capital stock from \$100,000 to \$130,000. The company has adjusted itself to the newer conditions created by the automobile industry and will devote its attention mainly to this line.

The customs officials in India are instructed to license importation of motor accessories and parts, provided they are imported genuinely for the purpose of repair and not for assembling into new cars. There is no intention of placing any material restrictions on the importation of bona fide accessories, even if these go into stock, so long as they are not apparently intended for assembling into new cars.

No more automobile trucks will be built for the present at the Ohio penitentiary at Columbus because of inability to get parts. If any more trucks are needed by the state they will be purchased. The penitentiary has made more than a dozen heavy trucks during the past two years.

# Vehicle Industry News in Brief

## Truck Builders

Brockway Motor Truck Co., Cortland, N. Y., has increased its capital from \$100,000 to \$500,000.

Landover Autotruck Co., Chicago, a Delaware incorporation, has increased its capital stock from \$300,000 to \$1,500,000.

Peerless Truck & Motor Corp., Cleveland, O., has been shipping 80 trucks a week since January 1, this being a new shipping record.

Hayes Motor Truck & Wheel Co., St. Johns, Mich., is erecting five dry kilns and has planned four more. Additional men are being employed.

Triangle Motor Truck Co., St. Johns, Mich., is planning to erect a factory, 60 x 150 ft., to turn out 900 one-ton trucks per year. Dr. Eugene Hart is president.

Union Truck Co., Morgantown, W. Va., has been incorporated, capital \$25,000, to manufacture motor trucks, by C. C. Brown, M. L. Clovis and E. M. Everly.

General Motors Truck Co., Pontiac, Mich., has received an order for 1,000 1½-ton chassis to be used for ambulances in the Medical Corps, United States Army.

Kissel Motor Car Co., Hartford, Wis., announces longer wheelbase and loading space and the all year cab as the outstanding features of the new line of Kissel trucks.

W. J. B. Motor Truck Co., Newark, N. J., has been incorporated with a capital of \$100,000. W. J. Baxter, H. F. Gleason and J. J. Bergen are the incorporators.

Hamilton Motors Co., Grand Haven, Mich., has about completed its factory buildings and will shortly turn out trucks in large numbers. It is capitalized at \$500,000.

Winther Motor Truck Co., Kenosha, Wis., is having plans prepared for the first unit of its motor truck factory. The building will be 100 x 500 ft., one story, and cost \$100,000 with equipment.

Brinton Motor Truck Co., Downingtown, Pa., recently incorporated, capital \$20,000, to manufacture motor trucks, has opened an office at 5740 Cherry street, Philadelphia. W. G. Edge is treasurer.

Bethlehem Truck Co., New York, has been incorporated with a capital of \$50,000, to manufacture motor trucks. J. T. Abeles, S. M. Lazarus and W. P. Riley, 2 Rector street, are the incorporators.

Trans-Mo Truck Co., Nashville, Tenn., has been incorporated with a capital stock of \$20,000, to build automobile trucks. The incorporators are S. O. Edwards, Charles H. Simpson, Anthony Sudekum and others.

Duplex Truck Co., Lansing, Mich., has started work on its new factory, which will be equipped and ready for operation by January 1. It will be two stories, of brick and steel, with 90,000 ft. of floor space and cost \$200,000. It plans to turn out ten trucks per day.

Sanford Motor Truck Co., Syracuse, N. Y., has been

reorganized to increase the capacity of its works and for general expansion. It will specialize in the production of one and two-ton internal gear drive trucks, and 2½ and 5-ton worm drive trucks. J. F. Durston is president; E. A. Kingsbury is treasurer and general manager.

Crescent Motor Truck Co. has been incorporated in New York state to manufacture a 1,500 lb. delivery car to be an assembled proposition and to sell around \$1,000. The company has taken temporary quarters at 1457 Broadway. Production is expected to start by September 1. The company is a closed corporation with a nominal capital of \$6,000. J. W. Brooks is president.

Lapeer (Mich.) Tractor Truck Co. has been organized with offices at 2058 Penobscot Building, Detroit, and a service station at 22-32 Brady street. Benjamin W. Cutting is president; Thomas W. Payne, vice-president; M. E. Ryan, Jr., secretary and treasurer. S. B. Winn, formerly connected with the Packard and Studebaker companies, will be manager of the Detroit sales office.

Muskegon (Mich.) Engine Co., maker of valveless four-cycle engines, will soon begin the manufacture of motor trucks of one and two-ton capacity. The general offices, formerly in Grand Rapids, have been removed to Muskegon, and a new factory will be erected. C. E. Johnson, Muskegon, is president; H. L. Smith, Grand Rapids, vice-president, and Harry D. Hansen, Muskegon, secretary and treasurer.

The Reya Co., capital \$800,000, has been organized to take over the truck end of the Napoleon (O.) Co. The company is financed largely by eastern capital, and is now building a light special truck of unusual design and appearance. It will also build a ton and a ton and a half attachment. The president is J. J. Mullan, of the Wheellet Mfg. Co., 114 Liberty street, New York. The Reya truck will have a 3¼ x 4½ in. motor; Dyneto electric and starting system; Dixie high tension magneto; Peru axle; 117 in. wheelbase; standard tread; Babcock special bodies. The demands for the Napoleon trucks were so great the new company was organized to greatly increase the production, and deliveries are now being made.

## Body Builders

Lansing (Mich.) Body Co. is manufacturing ambulance bodies for the government.

Dayton (O.) Body Co.'s new plant is nearing completion and installation of machinery will be begun at an early date.

Wadsworth Mfg. Co., Detroit, maker of automobile bodies, tops, etc., has increased its capital stock from \$250,000 to \$650,000.

Hoskins Body Co., Chicago, has been incorporated with a capital stock of \$10,000, by J. C. and Byron Hoskins and J. G. Grogan, of Chicago.

Fleetwood (Pa.) Metal Body Co.'s new plant, to re-

place the one recently destroyed by fire, will be of brick, three stories, about 104 x 290 ft.

Wilson Body Co.'s plant, construction of which recently started in Bay City, Mich., is being rushed to completion and will be ready for occupancy by August 1.

All Season Body Co., Marshall, Mich., completed its first shipment of bodies June 30 and made shipment of them to the Briscoe Motor Co., Jackson, Mich.

Donald Schachinger has been appointed manager of the body building department of the Porter Mfg. Co., Ann Arbor, Mich. Mr. Schachinger was formerly with the Griswold Body Co.

Rex Mfg. Co., Connersville, Ind., maker of sedan tops, will erect an addition to its plant. The building, which will be of brick and concrete, will be three stories high with full basement, 100 x 60 ft.

Van Allen's Convertible Automobile Body Co., 133 Broadway, Paterson, N. J., has been incorporated with a capital of \$50,000, to manufacture automobile bodies. Charles H. Van Allen, Alfred H. Post and Alfred H. Post, Jr., are the incorporators.

Rinehart-Droxler Wagon and Auto Body Builders, Inc., Philadelphia, has been incorporated in Delaware with a capital of \$25,000, to build automobile and wagon bodies. George H. Rinehart, Edward M. Droxler and Charles M. Hogarth, Philadelphia, are the incorporators.

Appleton (Wis.) Body Co., which established a plant at Fremont and Jefferson streets in leased quarters in February, is having tentative plans prepared for a manufacturing plant, with wood and metal working shops, to be erected during the fall and winter. C. C. Seeger is vice-president and general manager.

Detroit Auto Products Co., Detroit, is rounding out its line of bodies. Two, and possibly three, closed bodies are to be added shortly, and the company is now branching out with a special department to produce custom bodies for the general trade in larger cars as well as small ones. The company reports a tendency of car buyers to seek light, economical machines with a touch of individuality to them.

### Car Builders

Biddle Motor Car Co., Philadelphia, has increased its capital from \$100,000 to \$250,000 for proposed expansion.

Russell Motor Car Co., 276 King street West, Toronto, will build a frame addition to its factory at a cost of \$7,500.

Dodge Brothers, Detroit, are taking bids for the erection of a seven-story brick and concrete addition to their plant, about 165 x 275 ft.

Carhart Motor, Oklahoma City, Okla., has been incorporated with a capital of \$500,000, by E. K. Seack, E. E. Beake and others, to manufacture motor cars.

Autocar Co., Lancaster avenue, Ardmore, Pa., manufacturer of automobiles and parts, is having plans prepared for a five-story reinforced concrete addition.

The Multi-Battery System, Chicago, is laying plans for the production of 1,000 electric runabouts. The machines are to be of a light type, weighing about 1,800 lbs., and will have chain-driven rear axles.

### Parts Makers

Spring Perch Co., Bridgeport, has increased its capital from \$50,000 to \$100,000.

Zenith Carbureter Co., Detroit, has contracted for the erection of a new four-story factory.

Ohio Carriage Mfg. Co., Columbus, is developing in connection with its own business an automobile robe and coat department.

Hayes Motor Truck Wheel Co., St. Johns, Mich., is planning to increase its equipment to manufacture 500 wheels a day instead of 200.

Silvex Co. has purchased ten acres of land adjacent to South Bethlehem, Pa., and will erect a new plant with a capacity of 12,000,000 spark plugs a year.

The factory to be erected on Calvert street by the Baltimore Buggy Top Co., 107 West Mount Royal avenue, Baltimore, Md., will consist of a four-story reinforced concrete building, about 75 x 120 ft.

Niswander Mfg. Co., Quincy, Ill., has been incorporated with a capital of \$7,000, to manufacture demountable rims for automobiles. The incorporators are John L. Niswander, Harry L. Bert and Fred C. Scholz.

William Brummeller Sons Co. began operations the last week of June in its new factory at Grand Rapids, Mich., where the company manufactures automobile fenders, running boards and other sheet metal parts. Twenty workers are employed.

Service Auto Wheel Co., Grand Rapids, Mich., has been organized with \$10,000 capital to manufacture demountable wheels and other appliances. The stockholders are Russell A. Bates, Thomas Vander May, Harry E. Draa and Edward S. Kinnie.

### Miscellaneous

Michigan Auto Trailer Co., Detroit, has filed a petition of bankruptcy. Liabilities, \$5,993.31; assets, \$10,088.27.

John Deere Wagon Co., Moline, Ill., has received an order for 850 army transport wagons to be completed immediately. About a year ago the company rushed an order of 1,000 wagons of this type through in a comparatively short time. The company expects to complete this order within a very few weeks.

### Battery Rental Plan for New Electrics

The Fashion Automobile Station, Inc., of Chicago, which is also an agency for electric automobiles, has developed a battery rental and exchange plan in connection with the sale of new cars.

Under this plan the new "electric" minus the battery is sold for \$1,485. The battery for the car is then rented for \$15 per month plus \$1 per battery change. The cars are equipped with a specially designed battery rack so that the battery may be changed in two and five-tenths minutes, or in less time than it takes to fill a gasoline tank. Changes can be made at any of the five stations strategically located in Chicago and its suburbs.

### Death of J. G. Delker

John G. Delker, founder of the Delker Buggy Co., Owensboro, Ky., died at his home in that city on June 9. He had been in ill health for several weeks from heart disease. He was born in Henderson county, December 9, 1842, and went to Owensboro to engage in business in 1863. Mr. Delker was prominent in business affairs in Owensboro, and at the time of his death was the president of the Owensboro Ice Co. and Owensboro Sewer Pipe Co., both of which institutions he organized many years ago. Other institutions closely connected with the industrial life of the city which Mr. Delker was instrumental in organizing, and of which he was an officer in time, were: The Owensboro Wheel Co., Owensboro City Railway Co., Owensboro Furniture Co., Delker Buggy Co., Delker Bicycle Works, and the Tanning Company.

### Death of J. W. McLetchie

J. W. McLetchie, for the past ten years representing the St. Marys (O.) Wheel & Spoke Co. on the road, died at the Hotel Normandie, Detroit, on Wednesday, April 11. "Mac," as he was commonly called, will be sadly missed by the vehicle industry and his place will be difficult to fill because of the close friendship in which he was held by members of the industry.

Earl W. Essman, who has been with the company for a number of years in the office and factory, will cover Mr. McLetchie's territory.

### Death of E. W. Ansted

Edward W. Ansted, president of the Lexington-Howard Co., Connersville, Ind., died the latter part of June, leaving behind a large array of business interests in addition to the Lexington-Howard car. He first started in business over 30 years ago in Racine, Wis., where he made springs. From this he went naturally into the manufacture of other wagon parts and finally complete carriages. When the demand for automobile parts arose he made those too, and even turned out complete cars for others, finally forming the Lexington-Howard Co.

### Death of W. H. Bowman

The death of W. H. Bowman, well known traveling representative of the Sheldon Axle & Spring Co., Wilkes-Barre, Pa., has been announced. The deceased was a familiar figure at the conventions of the Carriage Builders' National Association.

### Racine Tire to Manufacture on Large Scale

Plans have been adopted for newer larger buildings for The Racine (Wis.) Auto Tire Co. that will enable it to increase its daily production to 7,500 tires and tubes. The new plant will be five stories and basement and will be divided into units 60 ft. wide with courts 30 ft. wide between sections covering a plot 260 x 320 ft. The building will be constructed of reinforced concrete, and in equipping the power house electrical equipment of the latest patterns will be adopted. The working force will be increased from the present payroll of about 150 men to between 3,000 and 4,000. With complete equipment the cost of the new plant is estimated at \$300,000. Construction will begin about August 15.

The company was organized in 1910 to take over the

Beebe-Elliott Co., at which time it also discontinued the manufacture of leather treads which the old company made. In each of the past three years it is reported to have practically tripled its output. Figures for sales up to June 1 of this year are said to be greater than those for the entire year in 1916.

Clarence Wright, secretary-treasurer, has been manager since the company's formation. Other officers are: L. J. Elliott, president, and J. H. Wright, vice-president. In addition to the officers the board of directors contains the following names: T. H. Spence, Milwaukee; F. L. Sivyer, Northwestern Malleable Iron Co., Milwaukee; H. P. Andrae, Julius Andrae & Sons, Milwaukee; and Albert Brehm, Brehm Bros., Burlington.

### Patent and Enameled Leather Manufacturers Meet

At the regular spring meeting of the Patent and Enameled Leather Manufacturers' Association, held at the Downtown Club in Newark, N. J., May 16, the following officers were elected:

President, R. G. Good, Lackawanna Leather Co., Hackensack, N. J.; first vice-president, A. Rothschild, Stengel Rothschild Co., Newark, N. J.; second vice-president, Fred C. Fabel, American Oak Leather Co., Cincinnati; secretary, treasurer and counsel, James B. Reilly (re-elected). Directors: Harry N. Hill, Cleveland (O.) Tanning Co.; Max Hertz, Max Hertz Co.; Robertson S. Ward, General Leather Co.; Theo. S. Miller, John Reilly Co.; Herbert Gay, Blanchard Bro. & Lane; and B. W. Strauss, M. Strauss & Sons, Newark, N. J.

The following resolution was adopted:

"Resolved: That while we oppose at all times any and all taxes or tariff duties on foreign hides, and only accede to the proposed war measure tariff of 10 per cent on imported hides through a realization of our patriotic and citizenship duties, we strongly condemn any plan or proposition to tax domestic hides to like amount of 10 per cent, as we consider such action as militating against our better industrial interests."

Luncheon was served preliminary to holding of the meeting.

## WANTS

Help and situation wanted advertisements, 1 cent a word; all other advertisements in this department, 5 cents a word; initials and figures count as words. Minimum price, 30 cents for each advertisement.

**Wanted**—Copies of The Hub of May and July, 1916. Must be in good condition. Address Trade News Publishing Co., corner Elm and Duane streets, N. Y. City.

### PATENTS

**Patents**—H. W. T. Jenner, patent attorney and mechanical expert, 606 F St., Washington, D. C. Established 1883. I make a free examination and report if a patent can be had and exactly what it will cost. Send for circular.

### FOR SALE

**For Sale**—"Motor Body Work for Commercial Cars," a new text book dealing with the construction of all types of bodies for business purposes. Contains also six working drawings and a glossary of technical terms, together with diagrams and sketches. Price, \$1.20 net; by post, \$1.56. Orders should be accompanied by remittance. Cooper's Vehicle Journal, Ltd., 19 Garrick street, Long Acre, London, England.

# SHEET METAL STAMPINGS AND SPECIALTIES

Send us your inquiries and specifications for Sheet Metal Stampings of any kind. Our experience covers 40 years in this class of work in all kinds of metals.

Our equipment includes not only presses but electric welding machines, japanning ovens, etc., enabling us to finish complete any parts ready for immediate use, saving you this additional cost.

Our capacity for this class of work enables us to produce several hundred thousand pieces per day. Special attention is given rush orders. Catalog sent on application.



**Peter Gray & Sons, Inc.**  
Cambridge, Mass.



## Acme Die-Castings Superior for Automobile Parts Accuracy Guaranteed

Acme Die-Castings combine accuracy, strength, toughness and beauty of finish. Acme Die-Castings are accurate to the thousandth of an inch. They are clean, smooth, free from defects—ready for assembling when delivered. Send a model or blue print of your work for estimate.



Boston  
Philadelphia  
New York  
St. Louis

Detroit  
Chicago  
Rochester  
Pittsburgh

### Index To Advertisers

Acme Die-Casting Corporation.....	36
American Motors Corporation.....	4
Barrell Co., Wm. L.....	42
Bay State Pump Co.....	39
Bela Body Co., The.....	43
Bliss, E. W., Co.....	3
Bookwalter Wheel Co.....	44
Bradley, C. C., & Son.....	45
Brennan Motor Mfg. Co.....	47
Bridgeport Coach Lace Co.....	37
Columbus Bolt Works.....	Back cover
Cowles, C., & Co.....	44
Crane & MacMahon, Inc.....	Back cover
Decker, J. C.....	44
Dixon, Joseph, Crucible Co.....	8 and 9
Dowler, Chas. L.....	44
DuPont Fabrikoid Co.....	42
Eccles, Richard, Co.....	46
Empire Art Metal Co., Inc., The.....	40
G & O Mfg. Co.....	47
Gray, Peter, & Sons, Inc.....	36
Hartford Auto Parts Co.....	3
Hoopes Bro. & Darlington.....	47
Hotel Brunswick.....	45
Hotel Tuller.....	38
Jenner, H. W. T.....	35
Johnston, R. F., Paint Co.....	44
Keratol Co., The.....	42
Laidlaw Co., The.....	2
Lumen Bearing Co.....	41
Millersburg Fifth Wheel Co.....	44
Mulholland Co., The.....	44
Murcott-Duden Co., The.....	2
Norton Grinding Co.....	5
Parrott Varnish Co., The.....	2
Pettingell Machine Co.....	7
Pittsfield Spark Coil Co.....	38
Porter, H. K.....	45
Pressed Steel Co.....	2
Quickwork Co., The.....	45
Rhodes Mfg. Co., The.....	45
Rome-Turney Radiator Co.....	46
Russell, Burdsall & Ward Bolt & Nut Co.....	45
Sheldon Axle & Spring Co.....	Front cover
Sherwin-Williams Co., The.....	41
Standard Oil Cloth Co., Inc.....	6
West Tire Setter Co.....	47
White-Quehl Mfg. Co.....	44
Wilcox Mfg. Co., D.....	47
Willey Co., C. A.....	46
Williams, J. H., & Co.....	10
Wing, Chas., Co.....	44
Yoder Company, The.....	Back cover



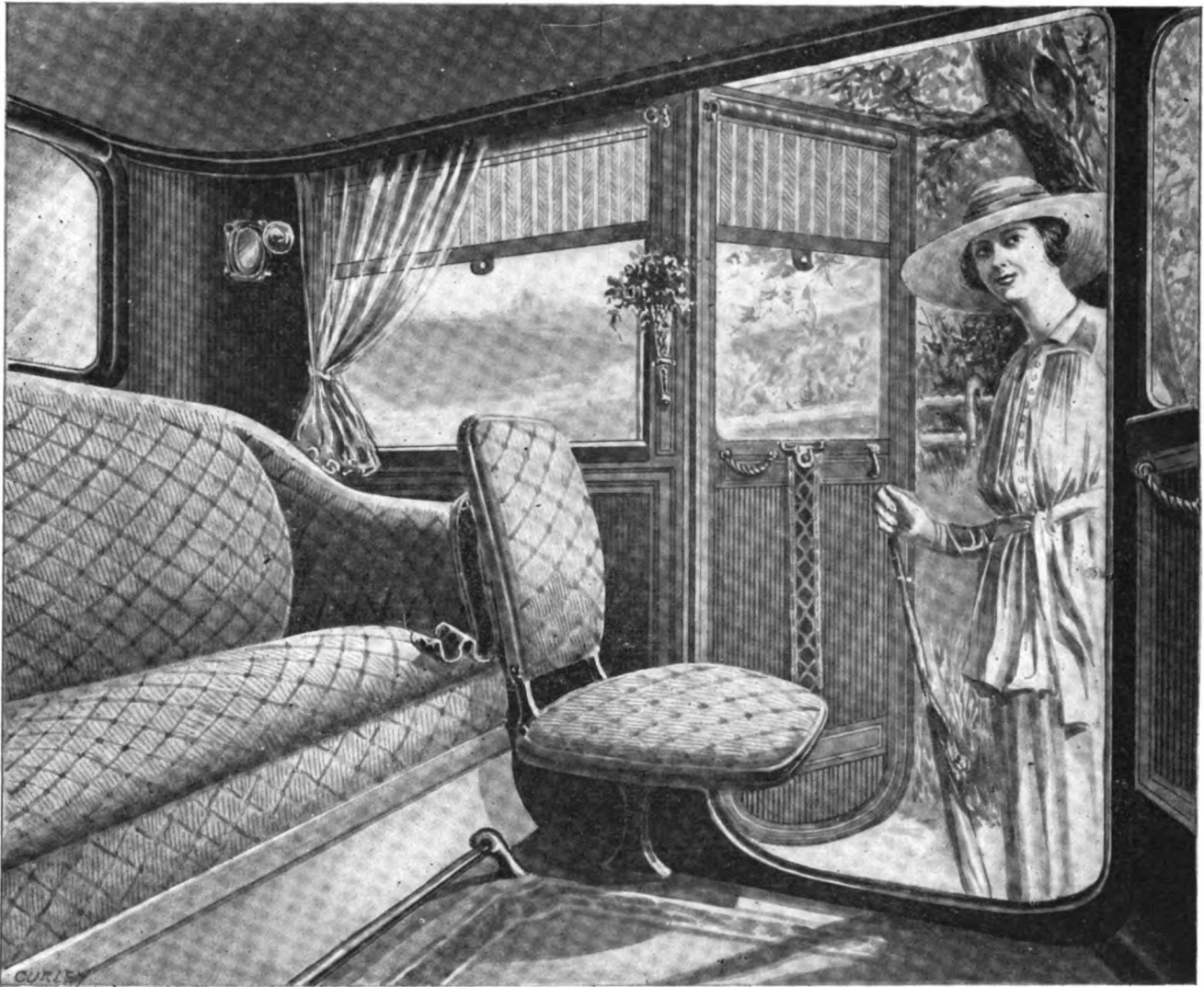

*Bridgeport Fabrics* are designed to meet the demands of the most exacting class of customers and are a requisite in the finishing of the finest motor car bodies.

## FABRICS BRIDGEPORT FABRICS

add the final touch of luxuriousness, quality and style to the handiwork of skilled workmen. A wide range of patterns and colors offers possibilities for the development of individual ideas almost without limit.

We invite an inspection of our samples.

**BRIDGEPORT COACH LACE COMPANY**  
**BRIDGEPORT, CONN.**

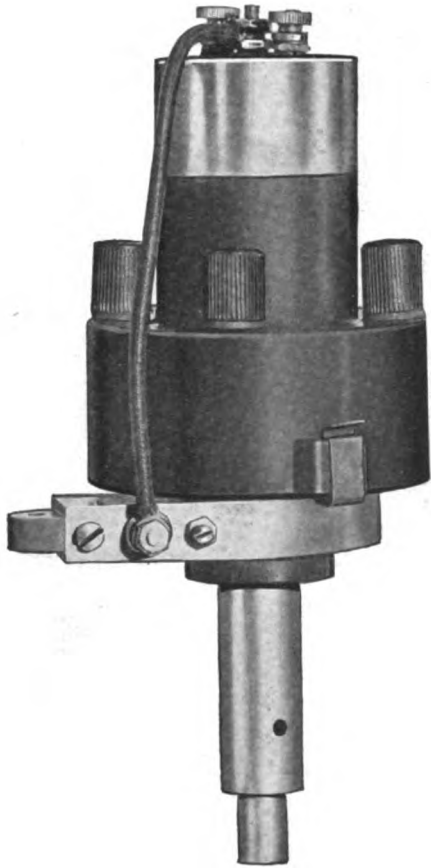

## A Perfectly Synchronized Spark at ALL Speeds

"Pittsfield" Distributor is of unit construction. It has an absolutely mechanical make and break which is positive and independent of spring action. No trips, hammers or other unreliable devices are required or used.

Its make and break is positive, giving a perfectly synchronized spark at all speeds. There is no lag in the spark—no automatic advances required.

Send for folder fully describing the "Pittsfield"

### FORD OWNERS

We have developed a special bracket for installing the "Pittsfield" Distributor on Ford Cars. Send for Folder.

Also manufacturers of "Pittsfield" Coils, Timers, Switches, "Berkshire," "Jewell," and "Micatite" Spark Plugs.

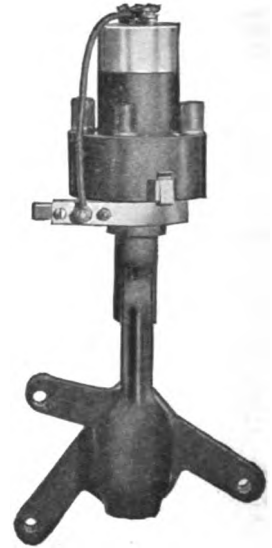

**PITTSFIELD SPARK COIL CO.**  
PITTSFIELD, MASS.



Meet me at the Tuller for Value, Service, Home Comforts

NEW  
**HOTEL TULLER**  
Detroit, Michigan

Center of business on Grand Circus Park. Take Woodward car, get off at Adams Avenue.

ABSOLUTELY FIREPROOF

200 Rooms, Private Bath,	\$1.50	Single,	\$3.00	Up Double
200 " " " "	2.00	"	4.00	" "
100 " " " "	2.50	"	4.50	" "
100 " " " "	3.50 to 5.00	"	5.00	" "

Total, 600 Outside Rooms

ALL ABSOLUTELY QUIET

Two Floors—Agents' Sample Rooms

New Unique Cafes and Cabaret Exellente

## Vehicle Mechanics

Desiring to improve their present Condition should attend the

## TECHNICAL SCHOOL

For

## Automobile Draftsmen and Mechanics

Supported by the

The National Automobile Chamber of Commerce, Inc.

The object of the School is to teach men to design vehicles and make working drawings, and to otherwise facilitate their work in the shop. Only those men employed in carriage or automobile building or their accessory trades are admitted to its privileges.

The classes are conducted in three divisions, viz.: Corresponding, Day, and Evening. The former is open during the entire year, while the day and evening classes are in session only from October 1 to April 1.

The tuition is moderate.

For prospectus and full particulars, write to the instructor,

ANDREW F. JOHNSON,

20 West Forty-fourth St.,

NEW YORK CITY

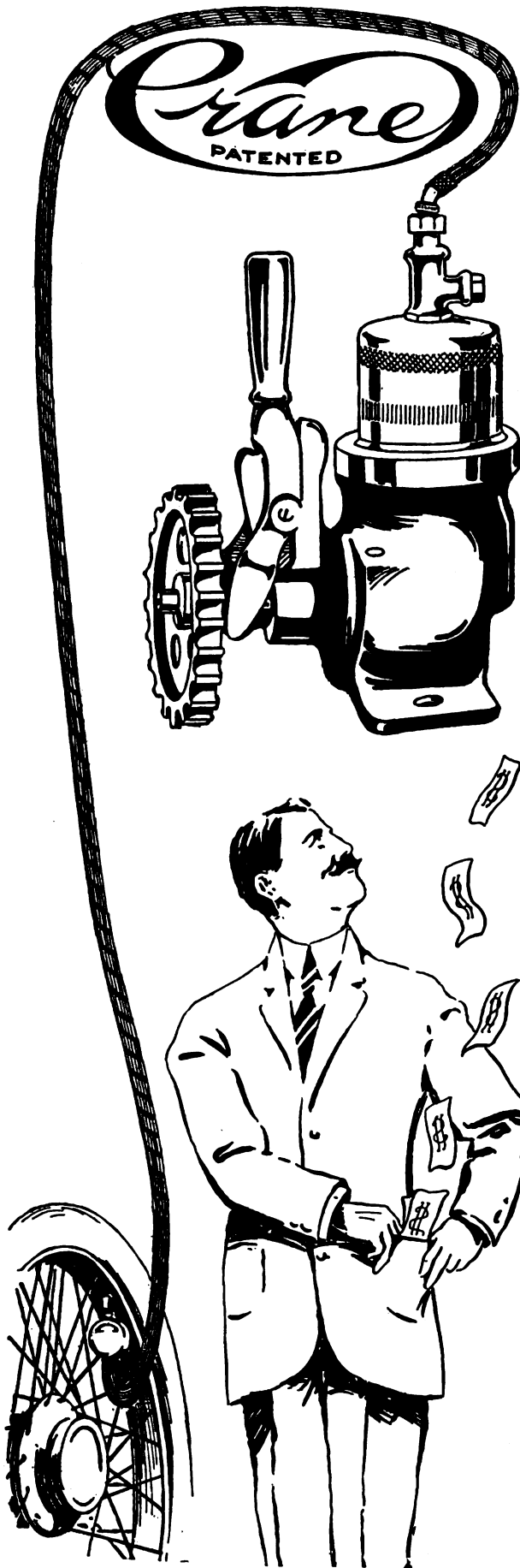

# 50 per cent More Efficient

## In Putting Air Into Tires and Profits Into Pockets

CRANE is the swiftest-selling tire-pump. Because it's 50% more efficient. And costs 50% less.

It delivers 50% more air than any other same-size pump. Because of its patented packing ring.

It puts more mileage into tires--by keeping oil out of the tubes.

It lasts longer and runs smoother--because every moving part is bathed in oil.

It adds less weight and requires less power--because it's HALF the size and has ONE-FOURTH the parts.

High efficiency is the result of simplicity. And simplicity means lower cost.

That's why you can sell more CRANES at \$10 COMPLETE--than other pumps costing twice the price.

Price includes Hose, Pressure-Gauge and Special Fittings for nearly every make and model car.

No holes to drill; no studs to drive. Attached in a jiffy. And sells on sight.

ORDER FROM YOUR JOBBER  
OR WRITE US

**BAY STATE PUMP COMPANY**  
100 Purchase Street                      Boston, Mass.



## Rapid Service

... on ...

## Steel Sash

Assembled or Unassembled

## We Are Prepared

To render rapid service on Special Wind Shields, Steel Mouldings, Angles, Channels and Irregular Shapes made to special requirements.

We have over 2,000 sets of rolls made for almost every conceivable requirement, such as are required in the construction of Automobiles, Bodies, etc.

Send us your blue prints.

We also solicit your inquiries on Special Steel Tubing, Round or Square.

## Empire Art Metal Co.

Incorporated

College Point - - New York



# SHERWIN-WILLIAMS VEHICLE FINISHES

A PRODUCT FOR EVERY PURPOSE, PRODUCING DISTINCTIVE RESULTS

*S-W METAL PRIMERS S-W BODY AND GEAR UNDERCOATINGS*

*S-W Q. D. COLORS S-W COLOR VARNISHES*

*S-W FINISHING VARNISHES*

EFFICIENT IN QUALITY AND UNIFORMITY

*THE SHERWIN-WILLIAMS Co.*

CLEVELAND

CHICAGO

NEWARK

MONTREAL

LONDON, ENG.

# MACHINEBRONZE

THE UNIVERSAL  
BEARING BRONZE



Carried in stock in solid and cored bars of 12" lengths—  
1/4" to 4 1/2" diameter, inclusive, by 1/8ths

Are Your Machines  
*Making Money, or  
Costing Money?*

Are your machines running steadily and MAKING money, or are they continually "down" for repairs and thus COSTING money?

If they are "down," worn bearings is probably the cause, as is the case nine out of ten times.

If you put cheap bearings in those machines that are "down," you'll no doubt have them "down" again in a short while.

It always pays to build them up with the best bearings you can buy. Bearings made of Machinebronze will cost you a little more, but consider the future shutdowns and overhauls they will save you.

You will be interested in our booklets.  
Send for them today

LUMEN BEARING COMPANY

BRASS FOUNDERS

BUFFALO

# Keratol LEATHER SKINS

For the car where leather has always been used



THE HOME OF KERATOL

PRICE

*Within Reason*

QUALITY

*Maintained*

W<sup>m</sup> L. BARRELL Co. 8 THOMAS ST.  
NEW YORK

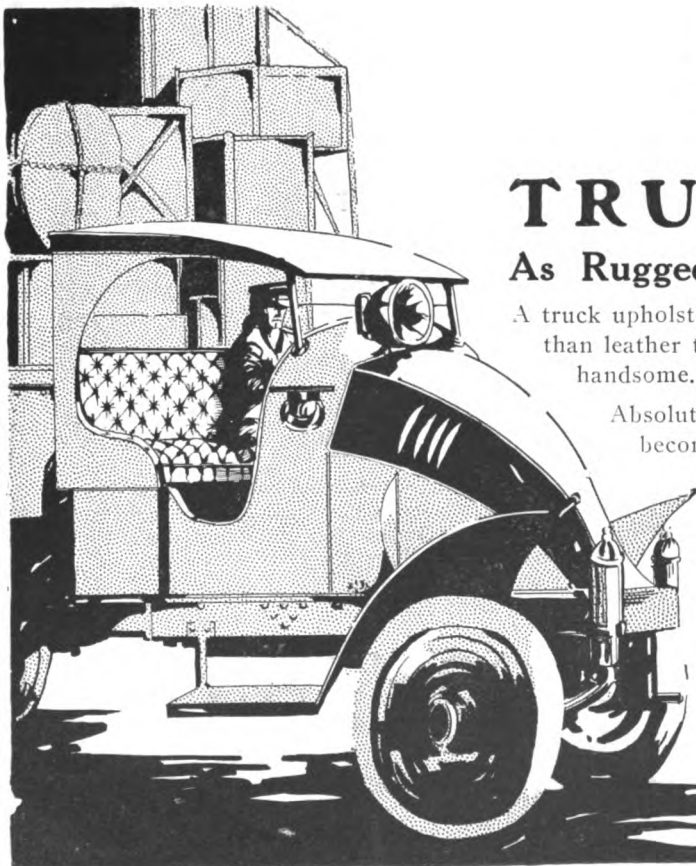

**F DU PONT  
FABRIKOID**

REG. U. S. PAT. OFF.

## TRUCK SPECIAL

As Rugged As the Service It Is Made For

A truck upholstery material that is built for business—far better suited than leather to extreme conditions of work and weather and just as handsome.

Absolutely waterproof, grease proof and washable—cannot become unsanitary.

Comes in 60 yard rolls, 50 inches wide, uniform in strength and thickness.

Cuts in multiples without waste.

TRUCK SPECIAL FABRIKOID makes for comfort, cleanliness and economy.

You should use it to save money

You should use it to save leather

Write for Truck Special booklet, samples and prices.

**DuPont Fabrikoid Co.**  
Wilmington, Delaware



# Distinctive Motor Bodies

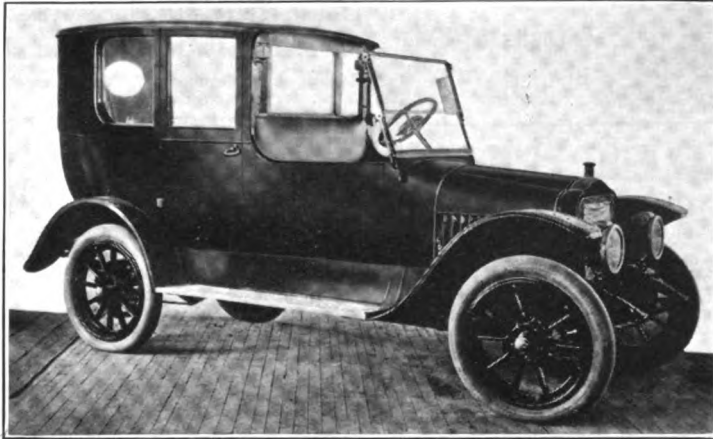

Seven-Passenger Town Car mounted on White Chassis

... FOR ...

Touring Cars

Landaulets

Limousines

Town Cars

Sedans, etc.

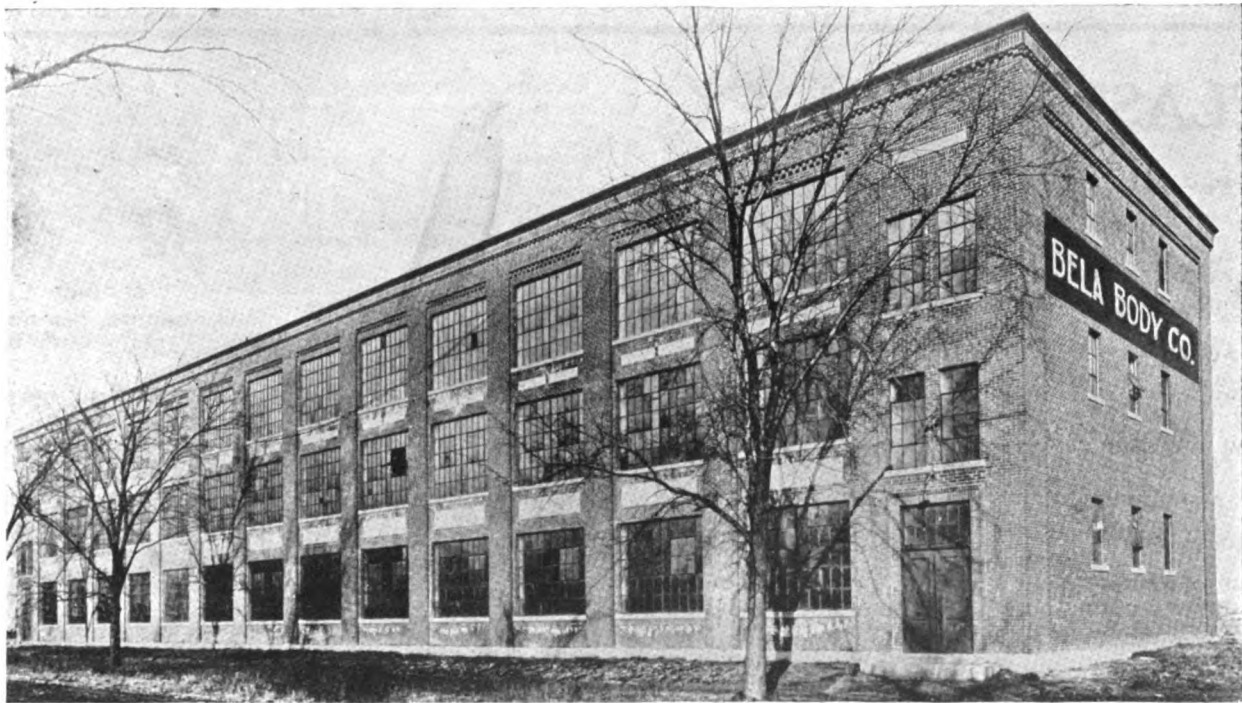

Our New Plant at Framingham, Massachusetts

This new up-to-date factory is used for the painting and trimming of our Bela Bodies, also for the final assembling and mounting.

Our new addition to this plant, 150 x 200 ft., will take care of our metal and woodworking departments, and there will be a full force of body builders in it in about three weeks.

The shipping facilities are ideal, being able to load our finished work on our own track on the B. & A. R. R. and the N. Y., N. H. & H. R. R. The whole plant is designed and built to give SERVICE and QUALITY WORK.

## BELA BODY COMPANY

FRAMINGHAM, MASS.

Please mention "The Hub" when you write

# BUSY BUYERS BRIEFS



Manufacturers  
**FIFTH WHEELS**  
All Varieties  
Heavy Goods a  
Specialty

Iron and Steel Rings from 4 to  
60 inches wide  
**MILLERSBURG FIFTH WHEEL CO.**  
Millersburg, Pa.

WE MANUFACTURE

**FINE VEHICLE  
WHEELS**

The Bookwalter Wheel Co.  
MIAMISBURG, OHIO

**JOHNSTON'S  
KRAKNO**

Color Card Free  
**\$3.50 per gallon**  
The R. F. Johnston Paint Co.  
Cincinnati, Ohio

**Why Not Have the Best?**



One of a Large Variety

**C. Cowles & Co.**  
NEW HAVEN,  
CONN.

**J. C. DECKER**

MONTGOMERY, PA.

Manufacturer of

**Carriage, Skate and Pad Straps**

Side Loops, Bridle Fronts, Tail Ties, etc.

**THE CHARLES WING CO.**

Established 1848

Manufacturers and Wholesale Dealers in  
**AUTOMOBILE AND CARRIAGE  
HARDWARE AND TRIMMINGS**  
AMESBURY, MASS., U. S. A.

**CHARLES L. DOWLER**

CARRIAGE AND WAGON HARDWARE

108 North Third St., Philadelphia, Pa.

**CUSHION MANUFACTURER**

Pure Stearic Acid Candles. Wheel Stock. Snow  
Flake Axle Grease.

**MULHOLLAND  
BUGGY SPRING**

Reduces weight of springs one-half.  
Made in one size only but will fit bodies  
of all widths.  
Write for further particulars and prices.  
**THE MULHOLLAND CO. DUNKIRK, N. Y.**

**White's Brazing Sleeves**



LINED

For applying Rubber Tires  
Send for Samples.



UNLINED

**WHITE-QUEHL MFG. CO.**

431 E. Pearl St.  
CINCINNATI, OHIO

## CLASSIFIED INDEX

For Addresses See Alphabetical Index  
and Advertising Pages

### AUTOMOBILES

American Motors Corp., Plain-  
field, N. J.

### AUTO FABRICS

Barrell, Wm. L., Co., New York  
Keratol Co., The, Newark, N. J.  
Laidlaw Co., Inc., The, New  
York.  
Standard Oil Cloth Co., New  
York City.

### AUTO PARTS

Hartford Auto Parts Co., Hart-  
ford, Conn.

### AXLES (Including Ball and Roller Bearing)

Sheldon Axle & Spring Co.,  
Wilkes-Barre, Pa.

### BODIES

Bela Body Co., Framingham,  
Mass.

### BOLTS AND NUTS

Columbus (O.) Bolt Works Co.  
Russell, Burdall & Ward Bolt  
& Nut Co., Port Chester, N.Y.

### BOLT CLIPPERS

Porter, H. K., Everett, Mass.

### BRAZING SLEEVES

White-Quehl Mfg. Co., Cincin-  
nati, O.

### BRONZE BEARINGS

Lumen Bearing Co., Buffalo.

### DIE CASTINGS

Acme Die Casting Corp., Brook-  
lyn, N. Y.

### DIES

Bliss Co., E. W., Brooklyn, N.Y.  
(Sheet Metal Working).

### FORGINGS

Eccles, Richard, Auburn, N. Y.  
(Carriage, Drop).  
Williams, J. H., & Co. Brook-  
lyn, N.Y. (Automobile, Drop)

### FIFTH WHEELS

Millersburg Fifth Wheel Co.,  
The, Millersburg, Pa.  
Wilcox Mfg. Co., D., Mechanic-  
sburg, Pa.

### HARDWARE (Carriage, Wagon and Automobile)

Columbus (O.) Bolt Works Co.  
Dowler, Chas. L., Philadelphia.  
Eccles Co., Richard, Auburn,  
N. Y.  
Wilcox Mfg. Co., D., Mechanic-  
sburg, Pa.  
Wing Co., Chas., Amesbury,  
Mass.  
Cowles, C., & Co., New Haven,  
Conn.

### LEATHER SUBSTITUTES

Barrell Co., Wm. L., New York.  
Keratol Co., The, Newark, N. J.  
Standard Oil Cloth Co., New  
York.  
DuPont Fabrikoid Co., Wil-  
mingt, Del.

### LUBRICANTS

Dixon, Jos., Crucible Co., Jer-  
sey City, N. Y.

### MACHINERY AND TOOLS

Bliss Co., E. W., Brooklyn, N.Y.  
Norton Grinding Co., Worces-  
ter, Mass.  
Pettingell Machine Co., Ames-  
bury, Mass.  
Rhodes Mfg. Co., The, Hart-  
ford, Conn.  
Smith, H. Collier Detroit, Mich.  
West Tire Setter Co., Roches-  
ter, N. Y.  
Williams, J. H., & Co., Brook-  
lyn, N. Y.  
White-Quehl Mfg. Co., Cincin-  
nati, O.  
Yoder Co., The, Cleveland, O.

### MACHINERY (Metal Working)

Bliss Co., E. W., Brooklyn, N.Y.  
Pettingell Machine Co., Ames-  
bury, Mass.  
Quickwork Company, Detroit,  
Mich.  
Yoder Co., The, Cleveland, O.

### METAL STAMPINGS AND NOVELTIES

Gray, Peter, & Sons, Inc., Cam-  
bridge, Mass.  
Murcott-Duden Co., Inc., New  
York.  
Pressed Steel Co. of New York,  
New York City.

### MOTORS

Brennan Motor Mfg. Co. Syra-  
cuse, N. Y.

### PATENTS

Jenner, H. W. T., Washington,  
D. C.

### PAINTS AND COLORS

Johnston Paint Co., R. F., Cincin-  
nati, O.  
Pierce Co., F. O., New York.  
Sherwin-Williams Co., Cleve-  
land, O.  
Wiley Co., C. A., Hunter's  
Point, N. Y.

### PRESSES

Bliss Co., E. W., Brooklyn, N.Y.  
(Drop, Power).

### RADIATORS

G. & O. Mfg. Co., New Haven,  
Conn.

Rome-Turney Co., Rome, N. Y.

### SCHOOL FOR DRAUGHTS- MEN

Mechanics' Institute, New York

### SHAFT COUPLINGS

Bradley & Son, C. C., Syracuse,  
N. Y.  
Eccles Co., Richard, Auburn,  
N. Y.

### SPARK COILS

Pittsfield Spark Coil Co., Pitts-  
field, Mass.

### SPRINGS

Mulholland Co., Dunkirk, N. Y.  
Sheldon Axle & Spring Co.,  
Wilkes-Barre, Pa.

### TIRE PUMPS

Bay State Pump Co., Boston,  
Mass.

### TOOLS

Williams, J. H., & Co. Brook-  
lyn, N. Y.

### TRIMMING MATERIAL

Bridgeport (Conn.) Coach Lace  
Co.  
Decker, J. C., Montgomery, Pa.  
Wing Co., Chas., Amesbury,  
Mass.

### UNIVERSAL JOINTS

Hartford (Conn.) Auto Parts  
Co.

### VARNISH AND JAPAN

Parrott Varnish Co., Bridgeport,  
Conn.  
Pierce Co., F. O., New York.  
Sherwin-Williams Co., Cleve-  
land, O.  
Wiley Co., C. A., Hunter's  
Point, N. Y.

### WHEELS

Bookwalter Wheel Co., Miamis-  
burg, O.  
Crane & MacMahon, Inc., New  
York City.  
Hoopes Bros. & Darlington,  
Inc., West Chester, Pa.

### WOOD BENDINGS, WHEEL STOCK, ETC.

Crane & MacMahon, Inc., New  
York City.

Please mention "The Hub" when you write



TEMPERED STEEL RING



LEATHER PACKING

The Only One-piece Moulded Leather Packing

## The Bradley Carriage Coupler

*All-Steel    Noiseless    Quick-Shifting    Ball-Bearing*

(MADE IN FIVE SIZES FOR AXLES 1/4 INCH TO 2 1/4 INCH)

The only carriage coupler that is furnished with a ONE-PIECE MOULDED LEATHER PACKING

**C. C. BRADLEY & SON, Syracuse, N. Y.**



SHAFT    LEATHER PACKING    AXLE

**The Bradley Carriage Coupler**

## THE BRUNSWICK



**Boylston Street, Corner Clarendon,**  
(Facing Copley Square)

**BOSTON - - MASS.**

High class modern house, intelligent service,  
pleasant rooms, superior cuisine.

Ladies traveling alone are assured courteous attention

European plan, single rooms, \$1.50 up; with bath,  
\$2 up; double, \$2 up; with bath, \$3 up.

American plan, \$4 per day up.

**FRED E. JONES - Proprietor**

## RHODES

### 7 in. Crank Shaper

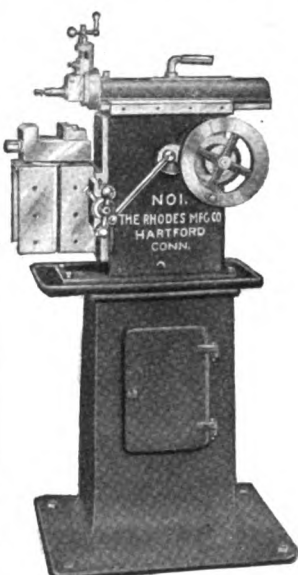

Designed and constructed for light and thoroughly accurate work, this small shaper has all the essential features of the large, high-priced machines. We build them horizontal, vertical, and a combination of the two.

They are light running and easy to handle, and for economical work on dies, tools, models, etc., their equal does not exist today.

Let us send you full description of these modern, improved machines.

**Rhodes Manufacturing Co.**  
**Hartford, Conn.**

**“Quickwork”**      Sheet Metal Working Machinery

For Automobile and Carriage Bodies, Fenders, Hoods, etc.

**THE QUICKWORK CO.**

H. COLLIER SMITH, Pres. and Gen. Mgr. ST. MARYS, O.

**PORTER'S BOLT CLIPPERS**  
“Easy” “New Easy” Allen-Randall



To Cut 5-16, 3-8, 1-2, 5-8, 3-4 Inch.

**H. K. PORTER,      EVERETT, MASS.**

# RUSSELL, BURDSALL & WARD BOLT & NUT CO.

Established 1845      PORT CHESTER, N. Y.

**MAKERS OF THE CELEBRATED EMPIRE BOLTS AND NUTS**

Western Office: Continental & Commercial Bank Bldg., Chicago, Ill. Branch Works: Rock Falls, Ill.

Please mention “The Hub” when you write

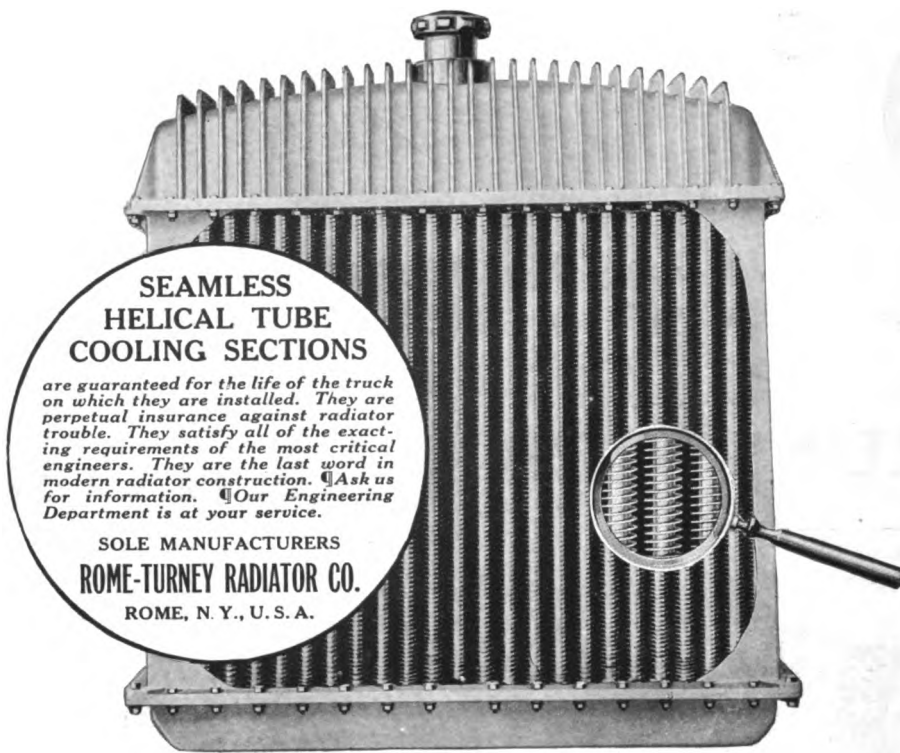

**SEAMLESS  
HELICAL TUBE  
COOLING SECTIONS**

*are guaranteed for the life of the truck on which they are installed. They are perpetual insurance against radiator trouble. They satisfy all of the exacting requirements of the most critical engineers. They are the last word in modern radiator construction. Ask us for information. Our Engineering Department is at your service.*

SOLE MANUFACTURERS  
**ROME-TURNEY RADIATOR CO.**  
ROME, N. Y., U. S. A.

**WILLEY'S  
COLORS**

The Recognized Standard



**C. A. WILLEY CO.**  
COLOR GRINDERS

and Manufacturers of Specialties in

**CARRIAGE, AUTOMOBILE and CAR**

**PAINTS**

**COLORS, VARNISHES, ETC.**

**HUNTER'S POINT, NEW YORK CITY**

**High Grade Forgings**

for **CARRIAGE, WAGON, AUTO-MOBILE** and **SPECIAL WORK**

**ECCLES BALL-BEARING COUPLINGS** are the **BEST** on the **MARKET** for **DURABILITY** and **EASE OF ADJUSTMENT**

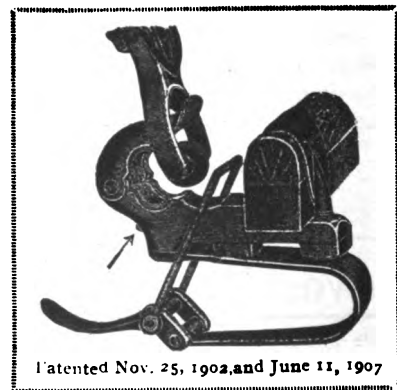

LEATHER BUSHINGS ARE FAST-ENED IN THE SOCKET WHERE THEY BELONG

SPECIAL FEATURE—THE SPRING IS PIVOTED AT THE FRONT TO ALLOW EASY ADJUSTMENT

Patented Nov. 25, 1902, and June 11, 1907

Please bear in mind that we make a **FULL LINE** of Carriage and Wagon Forgings, also many of those for Auto and Special Work.

Send for our new Catalogs showing our Regular and Special Forgings.

QUALITY GUARANTEED.

SERVICE—THE BEST

**Richard Eccles Co.**  
AUBURN, NEW YORK



# HOOPES BRO. & DARLINGTON

(INCORPORATED)

WEST CHESTER, PA.

WE ARE MAKING

# AUTOMOBILE WHEELS

Forty Years' Experience as WHEEL MAKERS is guarantee we can make good ones.  
Will not make any other kind. Try them.

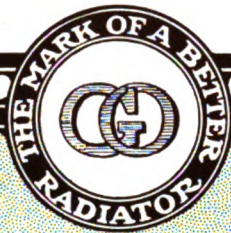

ENGINE COOLING

## RADIATORS

FOR PLEASURE CAR AND HEAVY DUTY SERVICE

G & O MFG. CO. - New Haven, Conn.

## WILCOX

FINE  
FINISHED  
FORGED

CARRIAGE HARDWARE  
AND GEAR IRONS

Write for Prices and Catalog

The D. Wilcox Mfg. Co.

MECHANICSBURG, PA.

## The WEST Hydraulic Tire Setter

WILL CUT DOWN EXPENSE

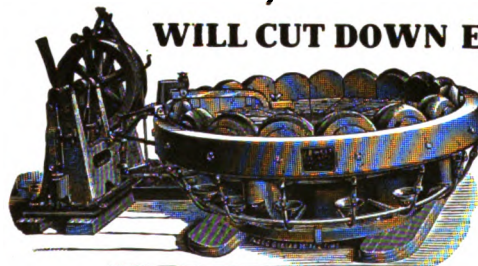

Tires set cold in one minute. This machine saves time—does the work better and quicker, does away with burned streaks. Only necessary to measure one wheel in a lot. Does not char the rim, and

thus make the tire loosen prematurely. Saves resandpapering of wheels. This machine is now increasing the profits of many manufacturers. Send for catalog and read about it.

WEST TIRE SETTER CO., ROCHESTER, NEW YORK

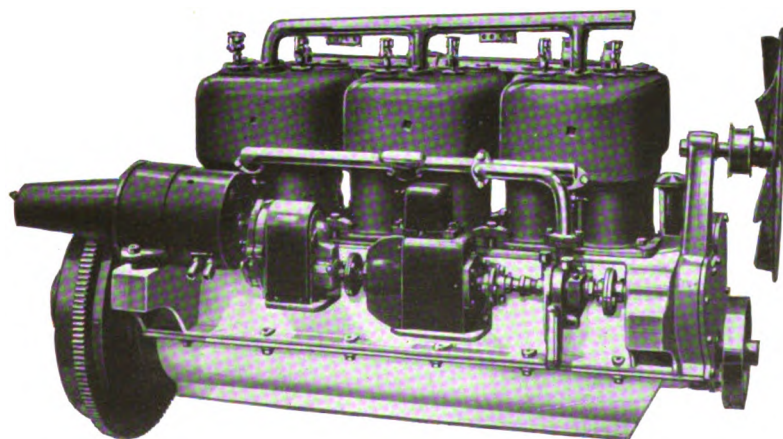

Model 6B Motor, 4 1/2" bore by 5" stroke

## Quality and Service

are the two essentials that for 17 years have been built into

## BRENNAN STANDARD MOTORS

The manufacturer of Commercial or Pleasure cars who equips his product with Brennan Standard Motors can feel assured his every requirement regarding this vital part has been fulfilled.

Built in the following sizes:  
4 Cylinder Model M—4 x 5    4 Cylinder Model 12—5 1/2 x 6  
4 Cylinder Model B—4 1/2 x 5    4 Cylinder Model 12—6 x 6  
4 Cylinder Model 11—5 x 5    6 Cylinder Model 6B—4 1/2 x 5

Let us send bulletins telling WHY Brennan Motors are STANDARD motors

Brennan Motor Mfg. Co., Syracuse, N. Y.

Please mention "The Hub" when you write

## The Hub

### AUTOTRUCK

#### Hickory Nut and

BEST QUALITY STOCK  
TOUGH AND HEAVY  
BONE DRY

MANUFACTURED BY  
CAPABLE MECHANICS  
AND MOST  
IMPROVED MACHINERY

WHEELS WHICH ADD TO  
THE LIFE OF YOUR TRUCK

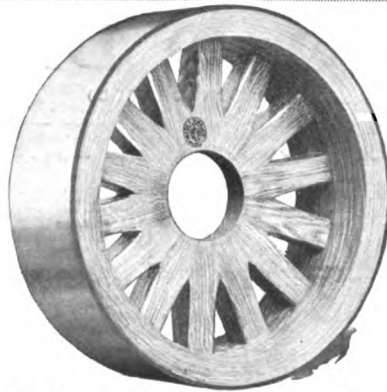

### W H E E L S

#### Acorn Brands

HORSE-DRAWN  
VEHICLE WHEELS  
ALL STYLES

TRAILER WHEELS:  
SARVEN AND  
ARTILLERY TYPES

HIGH STANDARD OF  
QUALITY AND  
WORKMANSHIP  
MAINTAINED

ST. MARYS, OHIO

CRANE & MacMAHON, Inc.

8 BRIDGE ST., N. Y. CITY

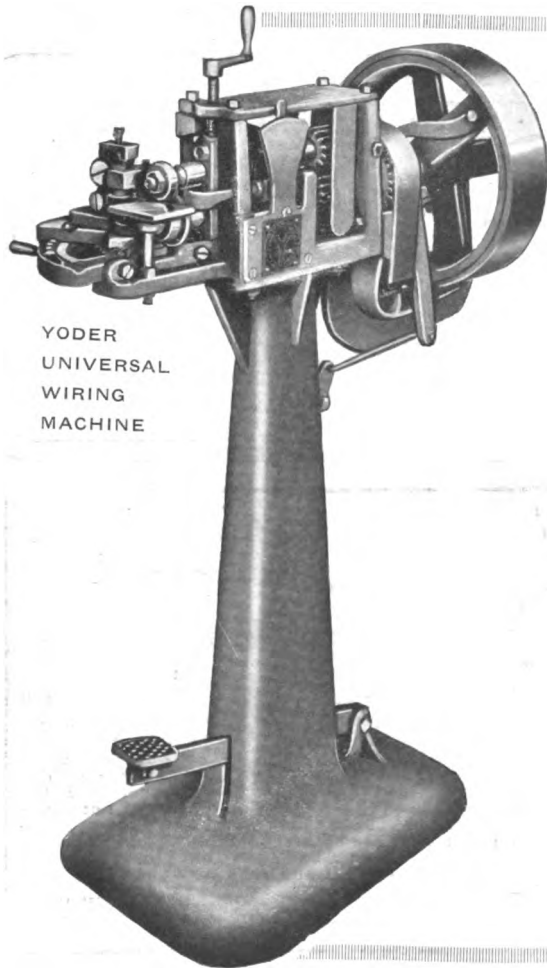

YODER  
UNIVERSAL  
WIRING  
MACHINE

## Yoder Sheet Metal Machinery

Our line of Auto Sheet Metal Working Machinery is efficient in every detail.

Every machine is constructed with the objective of producing perfect results at a minimum cost of material and labor.

The Yoder Company guarantees its machinery to produce results satisfactory to the purchaser.

We are glad to consider your Sheet Metal Machinery needs, as well as your requirements for special machines.

If you are thinking of making your own sheet metal parts or producing sheet metal products for the trade, get in touch with us at once. We can save you money and furnish a most satisfactory and complete equipment.

Catalog and prices furnished on request

## The Yoder Company

Engineers Building

CLEVELAND - - OHIO

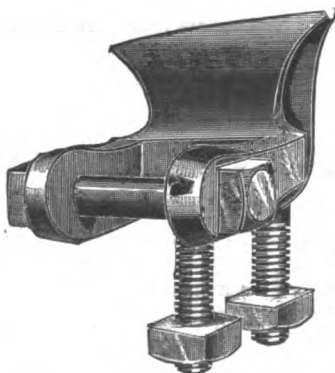

### Skewed Shaft Couplings

#### Regular or Oval Patterns For High Arched Axles

Furnished in rights and lefts for any height of arch.  
Oval Axle Clips  $\frac{5}{8}$  or  $\frac{3}{4}$  width to match Oval  
Couplings. Bolts, Clips, Couplings, Carriage  
Hardware and Special Forgings

Catalogue "H" and Prices on Application

**COLUMBUS BOLT WORKS COMPANY**

COLUMBUS, OHIO

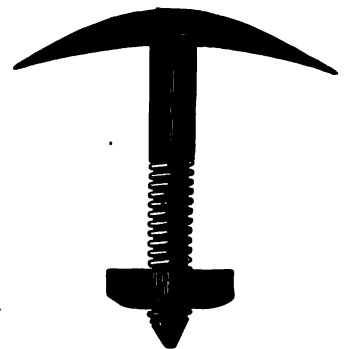



# The Hub

*First Journal of the Vehicle Industry*

Vol. LIX

NEW YORK, AUGUST, 1917

No. 5

**Witness  
a  
Drop-Forge  
Shop  
in action**

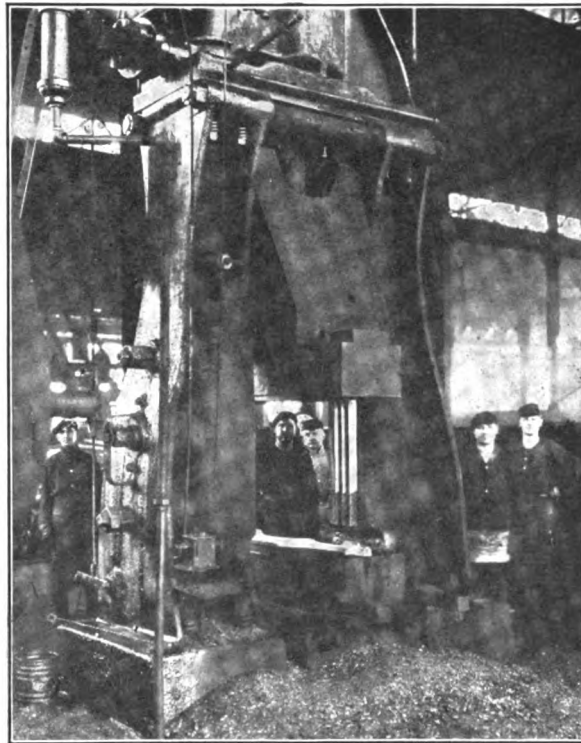

12,000 LB. DROP HAMMER

WHAT DROP-FORGINGS ENDURE THERE EXPLAINS WHY  
"SUPERIOR DROP-FORGINGS" ENDURE EVERYWHERE

**And  
you acquire  
a new idea  
of  
endurance**

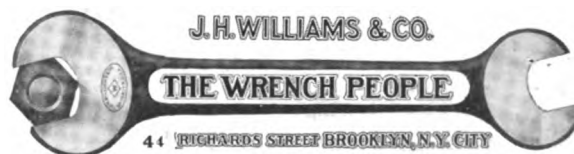
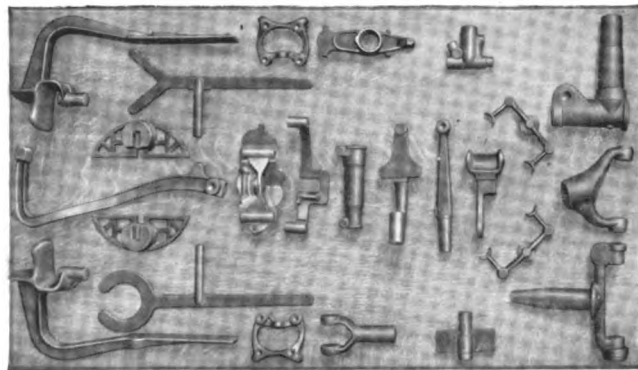

# PARROTT VARNISHES



.. Unequaled for ..

**Automobile  
and  
Carriage  
Finishing**

**The Parrott Varnish Co.  
Bridgeport, Conn.**



## SEAMLESS TUBING STEEL—BRASS—COPPER

**Send Us Your Specifications  
for Rush Requirements**

**MURCOTT-DUDEN CO., Inc.  
253 Broadway New York**



# steel stampings

*especially for*  
**COMMERCIAL TRUCKS**

**The Pressed Steel Company  
Wilkes-Barre, Pa.**

## The Laidlaw Company Inc.

New York City

.....

**Automobile  
Fabrics**

.....

**A Fabric for  
Every Purpose  
For Closed, Open or  
Convertible Bodies**

# A sure way to reduce your costs!

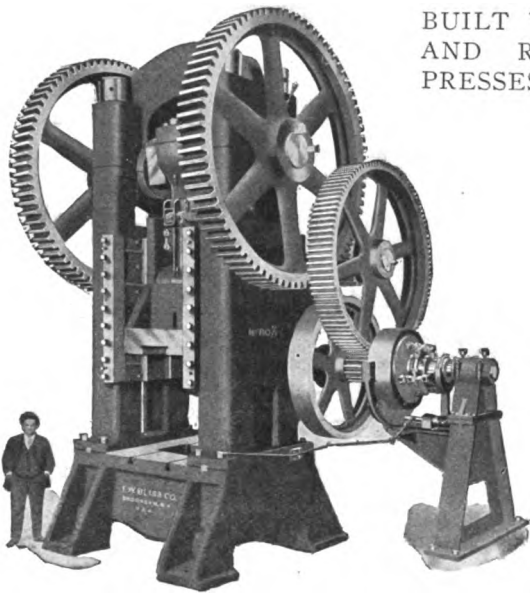

"Bliss" No. 80 1/2 Straight Side Press  
Weight, 175,000 Pounds

BUILT WITH THE GREATEST POSSIBLE STRENGTH AND RIGIDITY, BLISS STRAIGHT-SIDE POWER PRESSES MINIMIZE THE MAINTENANCE COST OF BOTH MACHINE AND TOOLS.

## Bliss Straight-Side POWER PRESSES

are being widely used for heavy punching, piercing, shaping, stamping and drawing operations in the manufacture of automobile parts, agricultural implements, electrical instruments, cutlery and heavy hardware. They are also adapted for trimming drop forgings, hot or cold.

Built in various sizes ranging in weight from 5,000 to 175,000 pounds.

**We are anxious to send you full details.**

Let us know your requirements and we'll be glad to offer you a few valuable suggestions. Write us at once.

### E. W. BLISS CO.

38 ADAMS ST., BROOKLYN, N. Y., U. S. A.

Chicago Office: Peoples Gas Building

Detroit Office: Dime Bank Building

Cleveland Office: Union Bank Building

Offices in Europe: 100 Boulevard Victor-Hugo, St. Ouen.

Paris: Poccock St., Blackfriars Road, London, S. E.



## Maximum Bearing Surface for Every Given Size

All unnecessary parts have been eliminated from Hartford UNIVERSAL DRIVES AND CONE CLUTCHES. They are light, yet exceedingly strong—simple in design—bearings are self-oiling.

They are high in quality, too—.40 carbon cold drawn seamless steel tubes being used for all shafts. The high carbon steel is made to special order by Carnegie Steel Co. and is always first analysed before being used.

Hartford UNIVERSAL DRIVES AND CONE CLUTCHES are used by some of the largest automobile manufacturers in this country. You, too, can use them to great advantage. INVESTIGATE!

## Hartford Auto Parts Co.

Hartford, Conn.

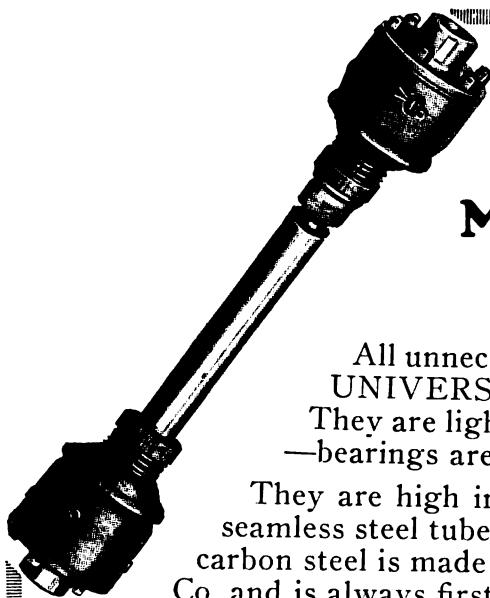

Please mention "The Hub" when you write

# LOOK INTO IT

---

**The Sales agency for the AMERICAN SIX represents an unusual money-making opportunity for readers of The Hub.**

**Get the whole proposition from the factory, Plainfield, N. J.**

**The car is six-cylindered, of beautiful design, big, roomy and mechanically right.**

45 horsepower  
122 in. wheelbase

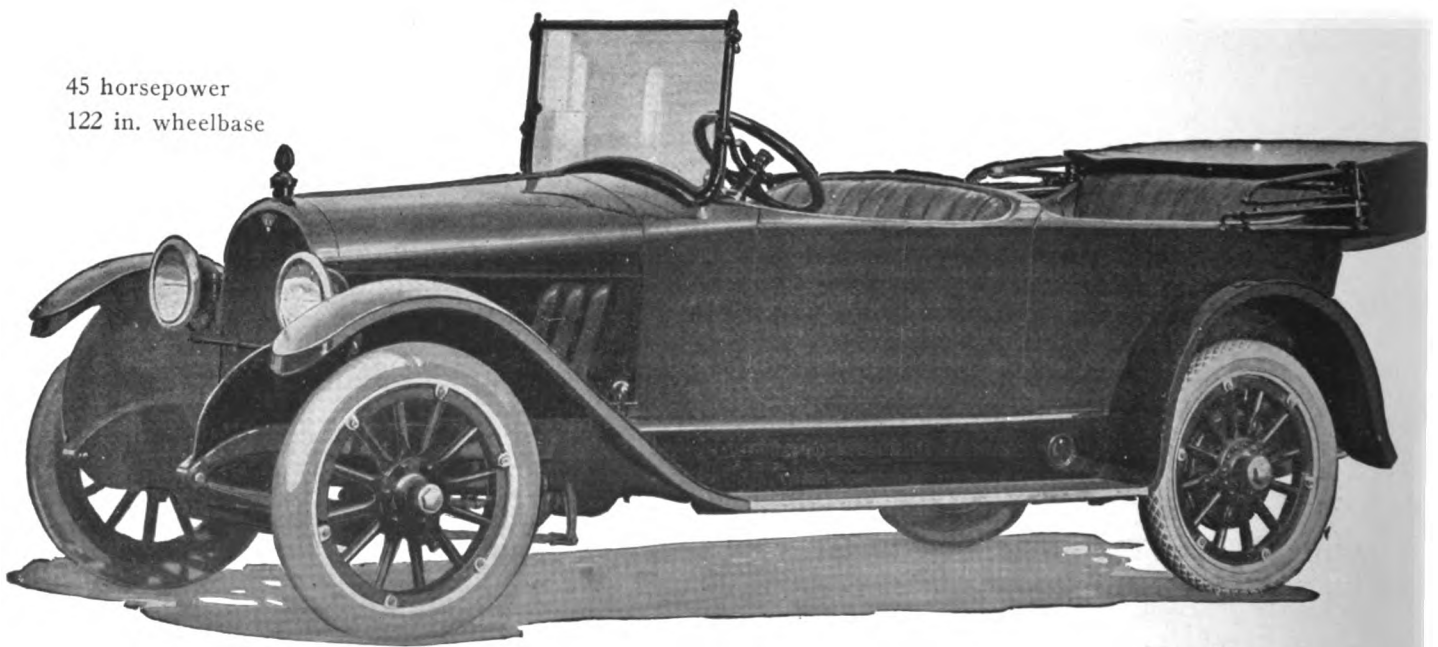

## AMERICAN SIX \$1375

---

**AMERICAN MOTORS CORPORATION, Plainfield, N. J.**

(25 miles from New York City)

Please mention "The Hub" when you write.

Digitized by Google

# Wanted!

## Quality Plus Quantity

At the plant of the Maxwell Motor Company, New Castle, Indiana, they wanted to increase their production and yet maintain the quality of the output. They did it by using a Norton Grinding Machine.

The parts ground are universal joint yokes. With a 60 M. wheel 2 1/4 in. face, 18 in. diameter, running about 1,500 r.p.m., with work rotating at 100 r.p.m., the output is 15 yokes an hour.

Have you a similar problem which requires speed as well as precision?

You will find the answer in a Norton Grinding Machine. Ask one of our special service men to talk it over with you.

**Norton  
Grinding  
Machine**

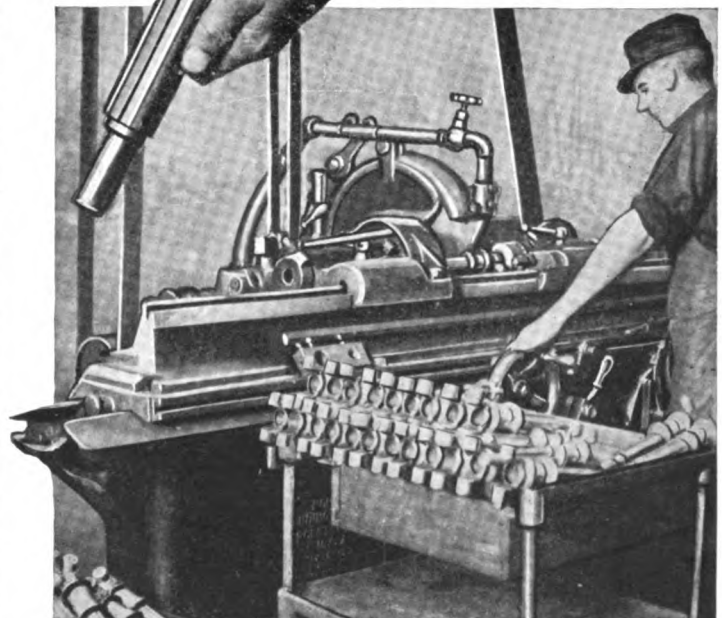
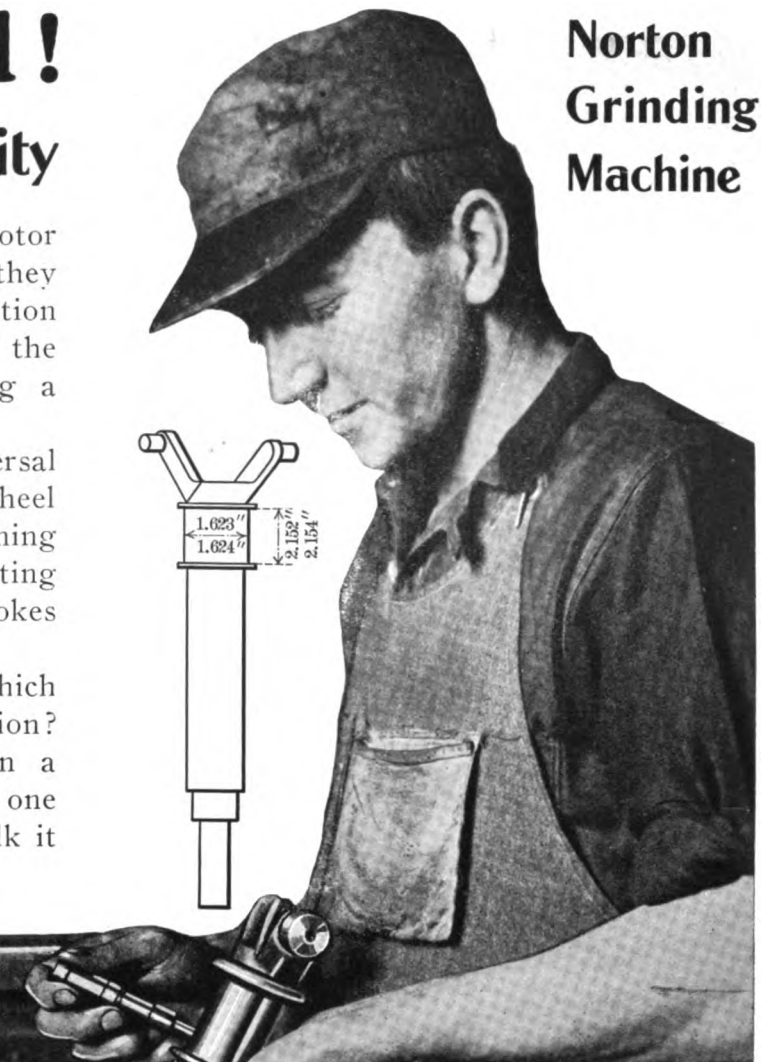
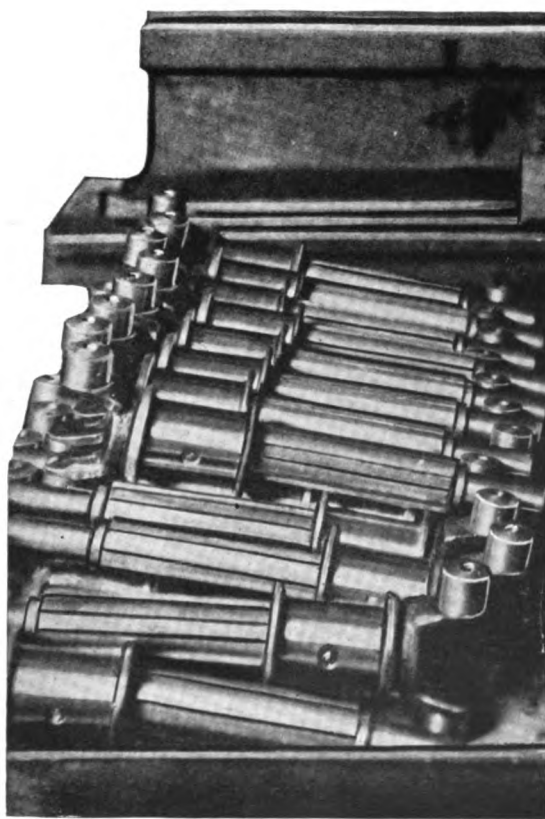
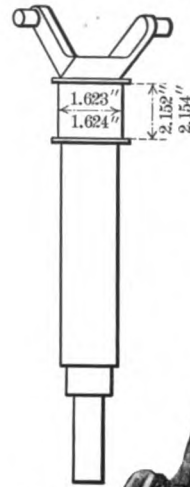

**NORTON GRINDING CO., Worcester, Mass.**

Chicago Store—11 North Jefferson Street

AGENTS—Vonnegut Machinery Co., Indianapolis; Robinson, Carey & Sands Co., St. Paul and Duluth; Manning, Maxwell & Moore, Inc., St. Louis; The Motch & Merryweather Machinery Co., Cleveland, Pittsburgh, Cincinnati and Detroit; Eccles & Smith Co., San Francisco, Portland (Oregon) and Los Angeles; Henry Prentiss & Co., Inc., New York, Boston, Rochester, Buffalo, Syracuse, Scranton; Canadian Fairbanks, Morse Co., Montreal, Toronto, Winnipeg, Vancouver; Alfred Herbert, Ltd., Coventry (England), Paris and Milan; F. W. Horne Co., Tokio, Japan; The W. E. Shipley Machinery Co., Philadelphia; Kemp Machinery Co., Baltimore; C. T. Patterson Co., New Orleans; Post Van der Burg & Co., Rotterdam; Iznosskoff & Co., Petrograd, Moscow and Ekaterinbourg, Russia.



# MERITAS

---

## LEATHER CLOTH

### The Leading Leather Substitute For Your Purpose

Whatever weight, color or finish you require in a dependable leather substitute you'll find it in the Meritas Leather Cloth line.

For years Meritas Leather Cloth has given complete satisfaction and service to hundreds of carriage and automobile manufacturers.

The quality is standard—every yard must pass our exacting inspection before it gets our trademark stamp of approval.

Look for the Meritas quality mark on the back of the goods.

#### Samples on Request

Simply state your requirements—we can deliver the right goods.

**The Standard Oil Cloth Company**

INCORPORATED

320 Broadway

New York





===== THE =====

# United States Government Canadian Government British Government

have all ordered and are using Pettingell Machines, and will soon place orders for many more.

If you want dependable machines that are recognized as the Standard for quality and production the world over—you will

## Eventually Buy Pettingell Machines

If you would save time, money and disappointments do it now  
Over 7,500 in daily use and not a disappointed customer

THIS FACT SPEAKS VOLUMES  
When you want the best order PETTINGELL Machines

Bevel and Mitre Saw Tables                      Improved Saw Tenoners  
Irregular Shapers

---

Automatic Power Hammers                      Friction Drive Rotary Metal Cutters  
Beading and Moulding Formers                      Rolling Machines  
Foot Presses                      Cornice Brakes, Etc.

---

MANUFACTURED BY

# THE PETTINGELL MACHINE CO.

AMESBURY, MASSACHUSETTS

Please mention "The Hub" when you write

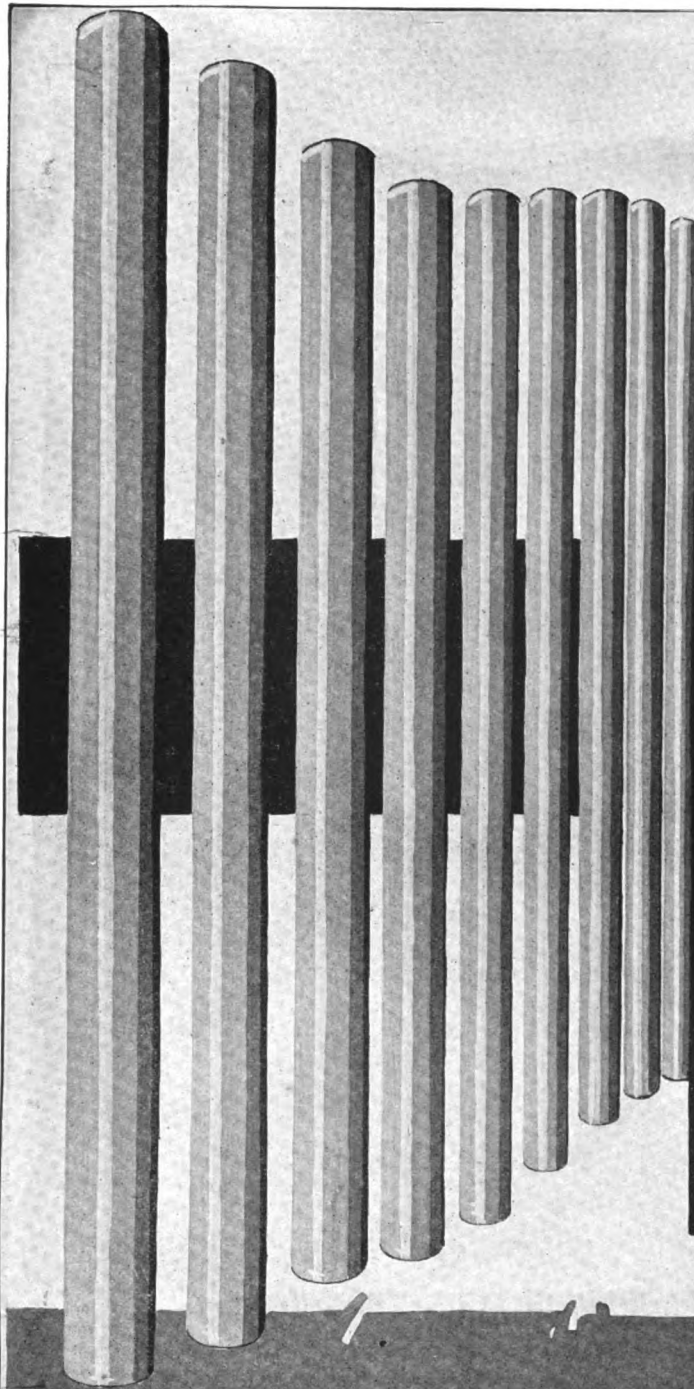

# EMPIRE STEEL TUBING

far excels ordinary tubing. It is especially prepared for the manufacture of *Automobiles, Auto Trucks, Aeroplanes, Motorcycles, Bicycles, Tricycles, Velocipedes, Beds, Baby Carriages, Pumps, etc.*

Made round or square, with welded, lock or open seams.

If you wish to manufacture products of the highest character insist upon *Empire Steel Tubing.*



**EMPIRE**  
**ART METAL CO**  
 INCORPORATED  
**COLLEGE POINT, N.Y.**

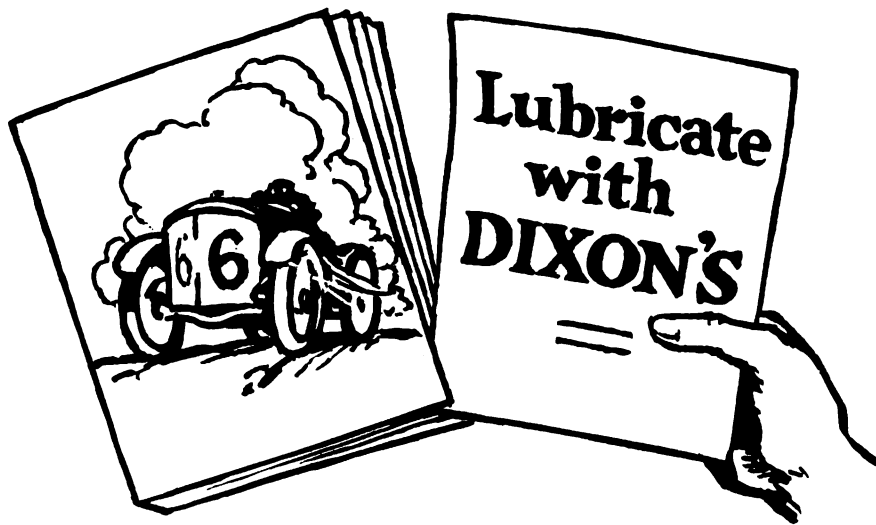

## A Lesson in Lubrication

Lubrication has been fifty years behind the science of mechanics. But the advent of the automobile caused an awakening. Since the first squeak was greased with a piece of Dinosaur fat, the greatest advance in lubrication has been the discovery of the value of flake graphite as a lubricant.

The squeak is the cry of the wear and tear of friction, caused by the grinding one over the other of microscopic spurs, pock-pits and other roughnesses that are present in even the most highly polished bearings. Oil and grease stop the squeak, but do not eliminate the grinding.

*Dixon's selected flake graphite fills up these irregularities of surface and makes a smooth, oily veneer that becomes harder and smoother and finer the more it is rubbed and used*

But all graphite is not lubricating graphite. To lubricate without balling up or packing, the flakes must be peculiarly thin, flexible and absolutely free from harmful impurities. Dixon's Selected Flake Graphite is absolutely the only graphite produced that has these qualities.

If you will put Dixon's Graphite Transmission and Differential Grease No. 677 into your cars, we guarantee you will live to swear by graphite lubrication.

Write to Dept. 123-G and find out how you can help your cars maintain their reputation.

**DIXON'S**  
GRAPHITE  
Automobile  
**LUBRICANTS**

Made in Jersey City, N. J., by the

**Joseph Dixon Crucible Company**



Established 1827



Please mention "The Hub" when you write

11

**T**HE average motor car in private use is lucky if it gets overhauled once a year. But how much better it would run could it but have the twenty-six thorough inspections and overhauls which are received, one every fortnight, by every

## *Fifth Avenue Bus*

**T**HIS IS THE DISCOVERY of the Fifth Avenue Coach Company after three years' thorough test of every type of axle and drive available. As the result of this test they have decided to use Sheldon Worm Drive Rear Axles exclusively in the future.

Sheldon Worm Gear Rear Axles are superior from the operating standpoint because they save maintenance costs in the following ways:

- 1—By permitting a demountable wheel, allowing inspection and wheel changes with minimum cost for labor and depreciation.
- 2—By having their wheel bearings enclosed in the main casing, protecting them from grit and thereby reducing the cost of bearing maintenance significantly.

Reduce Upkeep Costs Materially Because They Facilitate Frequent Inspection and Overhauling

3—By the superior construction of Sheldon brakes, giving longer service with maximum efficiency and requiring a minimum of inspection, adjustment and repair.

4—By securing the silent operation that the public is coming to demand.

THE SIGNIFICANCE of this three-year test by the Fifth Avenue Coach Co. is doubled by the fact that very few firms in the United States are in a posi-

tion to make so exhaustive a test. It brings out facts no manufacturer of trucks and heavy service vehicles can afford to neglect.

IF YOU ARE INTERESTED we can send you a reprint of a letter from the Fifth Avenue Coach Company giving their reasons for the adoption of Sheldon Axles in detail

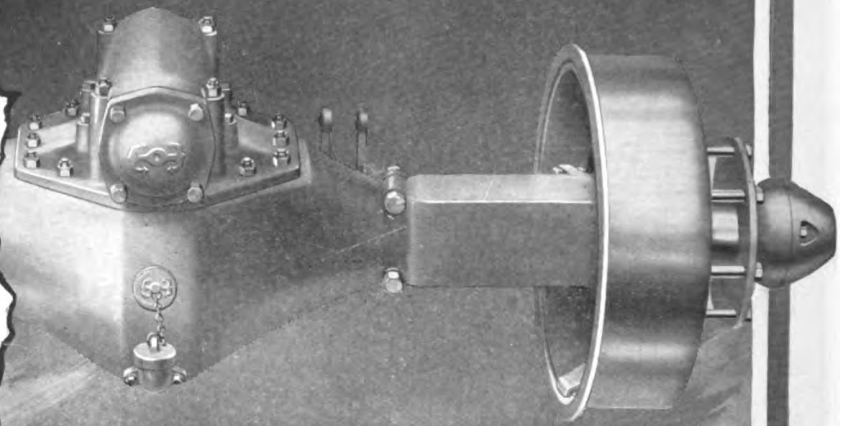

# SHELDON

## Worm Gear Rear Axles

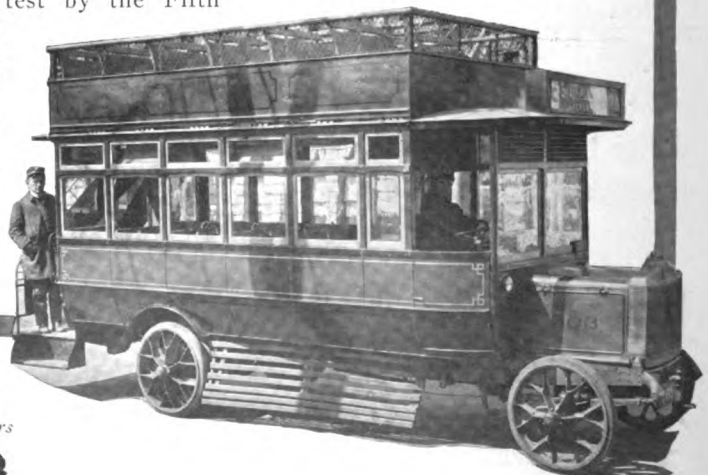

## Sheldon Axle & Spring Co.

Makers of Springs and Axles for Heavy Duty Service for over Fifty Years



WILKES-BARRE, PA.



# The Hub

Vol. LIX

NEW YORK, AUGUST, 1917

No. 5

Published Monthly by

## THE TRADE NEWS PUBLISHING CO. OF N. Y.

PAUL MORSE RICHARDS, *President* G. A. TANNER, *Secretary and Treasurer*

EDISON BUILDING, COR. ELM AND DUANE STS., NEW YORK

THE HUB, a monthly authoritative journal on all subjects pertaining to the vehicle industry from its engineering and construction viewpoints. It publishes information of live interest to manufacturers of motor vehicles, trailers, carriages, wagons, the accessory trades, repair shops and garages.

Subscription price for the United States, Mexico, Cuba, Porto Rico, Guam, the Philippines, and the Hawaiian Islands, \$2.00; Canada, \$2.50; payable strictly in advance. Single copies, 25 cents. Remittances at risk of subscriber, unless by registered letter, or by draft, check, express or post-office order, payable to the order of THE TRADE NEWS PUBLISHING CO.

For advertising rates apply to the publishers. Advertisements must be acceptable to publishers. Copy for new advertisements must be received by the 25th of the preceding month. All communications must be accompanied by the full name and address of writer.

Entered in the New York Post Office as Second-class Matter

### General Business Conditions

General trade has slackened somewhat, as is usual in mid-summer, but there is no let-up of activity in the industries, and no prospect of any. Labor difficulties are the most disquieting feature of the situation. The I. W. W. has been successful in temporarily paralyzing the copper mining industry in Montana and Arizona and the lumber industry in the Pacific northwest. Fortunately crop prospects give encouragement to the hope that the cost of living will be less this coming winter than last.

Efforts of government officials to control prices not only to the government but to the general trade have had some effect in influencing buyers, particularly in the steel trade, to hold off on purchases; but for months steel producers have had little to sell except for far-off deliveries. The mills are crowded to their capacity, with no prospect of relaxation while the war lasts. They are loaded up with government business and declining private orders, although trying as best they can to take care of regular trade. There is a great congestion of private business, and where so many people are wanting a commodity, willing to pay high prices to get it, and trying to outwit each other in getting it, prices inevitably rise.

Millions are being expended without regard to expense to enlarge the steel and iron capacity to supply the demand. At the moment it looks as though the high prices and uncertainty of deliveries had put an effective check on demand, and some weakening of prices is noticed; but it should be remembered that quotations in recent months have signified but little as to actual prices upon the bulk of production. Building operations in which steel is required have been brought almost to a standstill, so far as new work is concerned, and if this attitude is main-

tained by the public generally, a few months will bring about a readjustment of prices on a more practical basis. The August bulletin of the National City Bank of New York says that the most effective way of holding down prices is by having the buyers who can do so postpone their purchases. If consumption was not curtailed by high prices it would have to be arbitrarily curtailed by a selected distribution. The American public must reduce its competition with the government for the materials that are required for war use.

The transportation situation is much better, and the railroad committee at Washington is constantly developing its scheme of harmonious operation, but the volume of traffic is beyond all records, and an expansion of all facilities is very much needed.

### Business Genius Enlisted for the War

The government is going ahead with contracts in many lines, notably for aeroplanes, motor trucks, and miscellaneous supplies, and it is reasonable to expect that a fair basis of compensation will be reached upon all commodities.

The probability is that the industries and the government, as they work together for results, will come to a better understanding. The business men and engineers who have been called to Washington are rendering inestimable service. In providing for the supply of trucks the manufacturers have agreed to lay aside their own patterns and to all build a standardized truck, so that all parts will be interchangeable. The same thing will be done upon the aeroplanes, so that any number of factories can run on them. A new standard engine has been designed, known as the United States engine, which the experts do not doubt will be equal to any engine now made, and it will be used in all aeroplanes. The energy and genius of American business is enlisted for the war, and the resources of American industry are unreservedly at the government's command.

Orders for no less than 24,050 bodies for motor trucks have been placed by the government. The International Harvester Co., Chicago, will build more than a third of the bodies, its contract being for 10,000. The next largest contract is with the Grand Rapids School Equipment Co., of Michigan, for 6,400. The other awards follow: London Auto Supply Co., Chicago, 1,900; Mulholland & Co., Dunkirk, N. Y., 500; Hercules Buggy Co., Evansville, Ind., 400; Theodor Kundtz Co., Cleveland, 550; G. W. Stratton Co., Defiance, O., 1,000; Eagle Wagon Works, Albany, N. Y., 1,200; the Continental Car Co., Louisville, Ky., 2,000.



## Truck Building Program for Army Agreed On

The committee on automotive transport of the Council of National Defense on July 27 announced that, as an outcome of a conference of motor truck manufacturers, engineers, representatives of the Quartermaster Corps of the Army and of the committee held at Columbus, O., recently, the results of which have since been approved by the War Department, the truck makers of the country have agreed voluntarily to co-operate with the War Department in carrying through a continuing standardized truck building program for the requirements of the American army. The Columbus meeting was well attended by representatives of the industry, and its action, according to the committee, insures the organized assistance of the country's truck makers in providing an ample supply of military trucks for government service.

For immediate service in France, the government either already has ordered or will place orders in the near future for enough trucks of modified commercial type to take care of the first expeditionary forces. Even after the standardized truck is approved, such orders will be continued, so that the fullest possible use will be made of trucks of types now in the service of the Allies, which some American firms are now building.

In the meantime the Secretary of War has set aside from the contingent fund a sum sufficient to complete the work of standardizing parts for a military truck, based on the best American and foreign experience, which will serve in the future as the standard American army truck. Much of this work already has been carried out voluntarily by the members of the Society of Automotive Engineers, co-operating with the officials of the Quartermaster Corps. It is hoped that under the new authorization of the War Department the entire work of designing and testing will be completed before January 1 and that construction of the new standardized trucks can then begin.

The experts of the Quartermaster Corps, together with their civilian advisers, have reached the conclusion that it is only by a thorough standardization program, by which manufacturers of parts can all be turned to making the same interchangeable designs, that the army can be assured of ample supplies for possible greater demands on the capacity of the industry in the future. It is pointed out that not only will the demand for trucks grow as more American troops go abroad, but that, if future allied offensives should drive the fighting more into the open, more rapid and extensive supply transport facilities will be needed. The standardized truck whose design is finally to be completed under the department's authorization will be entirely suitable for commercial purposes, as well as being the best military truck yet designed.

### Coal Gas for Automobile Fuel

In England the gasoline situation is so acute that coal gas—the sort that is burned for illumination—is now being used for propelling automobiles.

Imagine a Ford car equipped with four uprights supporting a platform, or top, carrying a flexible gas holder 12 ft. long; the diameter, when fully inflated, 5 ft., and filled with 200 ft. of gas costing 12 cents sufficient to run the car with five passengers 17 miles over give-and-take roads. Our Ford friend in its latest design somewhat resembles a miniature "Zep."

The buses, so characteristic of English transportation (in 1913 they carried 750,000,000 people, 90 per cent as much as the electric tramways and 60 per cent more than the railroads) are reflecting the influence of the "Zeppelins," and more particularly the shortage of gasoline.

### Flexible Gas Holders

The Great Grimsby Street Tramways Co., Cleethorpes, have fitted some of their fleet with flexible gas holders, holding 600 cubic feet and requiring 12½ minutes to fill. These cars are of the Daimler make with 40 h.p. motors. No alteration to the carbureter was necessary beyond fitting a butterfly valve in the air-intake pipe, in order to enable the driver to regulate the air supply as required, and it was found that the best results are obtained with the valve nearly half closed.

Mr. White, of the above company, according to the London Commercial Motor, states that "the Daimler engine runs very smoothly on gas, accelerating with the same ease as when running on petrol (gasoline), and its pulling powers with a full load, both on the level and on hills, are the same as when on petrol."

Experience with this vehicle has shown a reduction in fuel cost per mile run from 9 cents to 3 cents, with petrol at 52 cents per gallon and gas at 60 cents per 1,000 cubic feet.

### Coal Gas Satisfactory

It is reported that the Grimsby company is so well satisfied with the results on coal gas that it is quite possible this fuel will be retained in preference when the supply of petrol returns to normal. Mr. White reckons that petrol will have to fall to 14 cents a gallon, or a reduction of 271 per cent from the prevailing cost, before he will be inclined to go back to it. The only disadvantages, to his mind, is the sacrifice of the top deck in order to allow the holder to be carried. He considers that with larger single deck bodies this difficulty will right itself.

Among the advantages in favor of gas which strongly appeal to the Grimsby officials are the following: (1) The engine keeps cleaner than with petrol, and the valves do not require grinding so frequently; (2) choked jets, punctured floats and other carbureter troubles are eliminated; (3) the lubricating oil in the engine keeps in better condition and lasts longer.

There is one trouble with the gas holder—the fabric is sometimes worn by its catching sharp projections. This is particularly noticeable when the container is confined within the usual top deck guard. The additional rubbing surface rapidly impairs the container by wearing out the fabric.

### May Produce Aluminum From Kaolin

Dr. F. C. Weber, a Chicago industrial chemist, says that it may be found necessary to produce aluminum from kaolin or fire clay in the near future instead of from bauxite, its present source. Owing to the enormous increase in the demand for aluminum for use in airplanes and automobiles, Germany has been obtaining aluminum from kaolin since its supply of French bauxite was cut off. According to Dr. Weber, this country's supply of kaolin is practically inexhaustible. The largest deposits are in Illinois. Weber has submitted his theory to the Society of Industrial Engineers, which, in turn, will take it up with the Council of National Defense.



Examples  
of  
Fine  
Custom  
Body  
Work

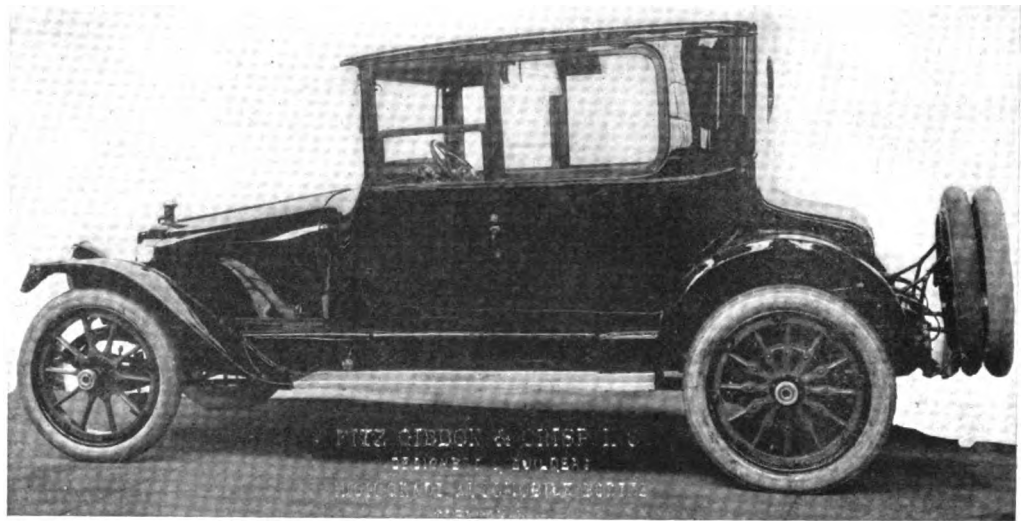

The first two illustrations on this page show exterior and interior views of a coupe body built by FitzGibbon & Crisp, Inc., Trenton, N. J. The coupe is mounted on a Packard chassis and has individual front seats with seat for two in the rear. The rear sash are removable and go in back of the rear seat. Sash in the doors drop and can be regulated according to the driver's convenience. The body is upholstered in cloth, and electric lights, toilet cases, smoking sets and all conveniences to bring it thoroughly up to date.

The sedan body in the lower illustration was built by the same company. It is mounted on a Stanley steam car chassis, and has ventilator in cowl, double rain vision windshield, sash to drop in the door, other sash removable, with Yale lock in the doors, upholstered in grain Spanish leather, electric dome light, also step lights.

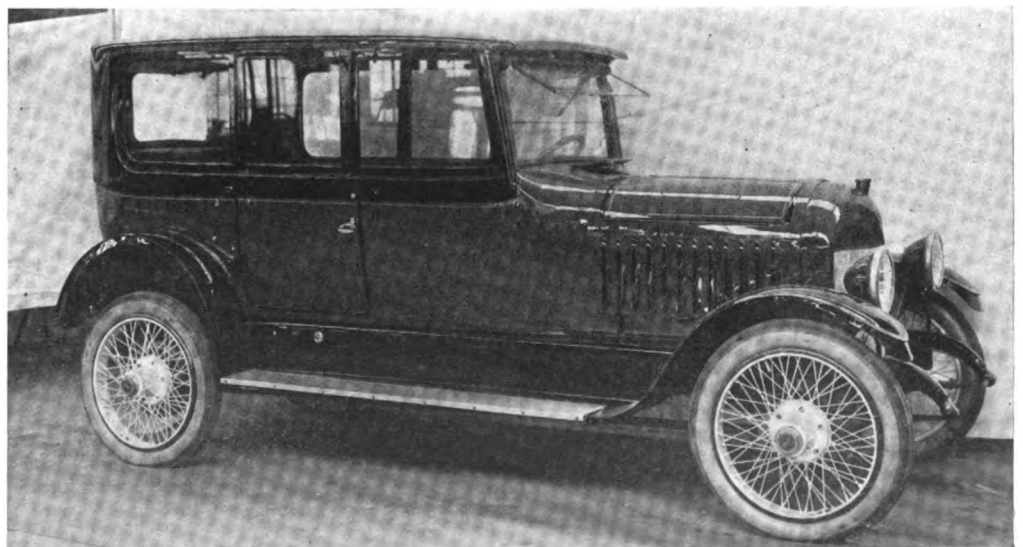

### Third Series Packard Twin Six

Changes in body lines are the principal features of the 1918 Packard—a new creation, yet distinctly Packard. A streamline design has been produced by a higher and narrower radiator, the top line of the body carrying back in an unbroken sweep to the rear curve of the car. The cowl has been merged into a combination of the hood.

Seven passengers can ride in perfect comfort in the roomy body of the standard touring car. The extra seats are of the forward-folding disappearing type. Both front and rear compartments are upholstered in hand-buffed, straight-grain leather in the new plaited style.

The running board has been cleared by removing the battery to the right side of the frame, under the front floor boards. The control board has been removed from the steering column and the controls conveniently located on a cowl board. The windshield has been closely fitted, set at an angle, and in the open cars both halves are fully adjustable. Fenders are of new design, semi-crowned.

The electrical system is a single-wire system with a grounded return instead of the two-wire system. The chassis is made in two wheelbase lengths instead of four, as last season. The engine has a hot spot in the intake manifold to assist in vaporizing the inlet gases, and there

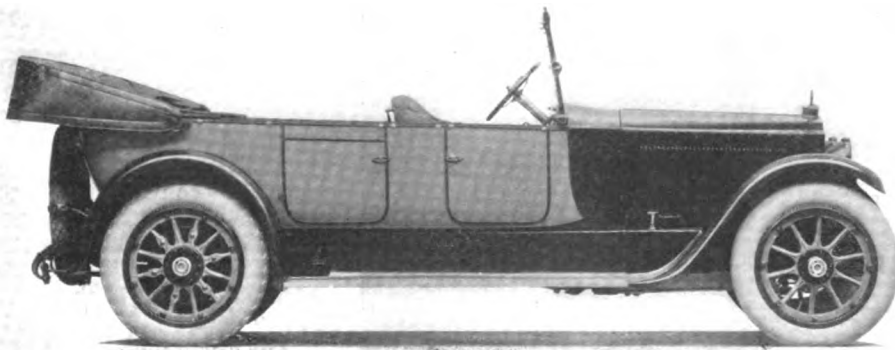

1918 Packard seven passenger touring car

is also a difference in the arrangement of the inlet passages to permit a better distribution of the gases.

No extra charge is made for special painting when it is confined to body panels, door panels, wheels, bonnet, moldings and cowl. Door handles on all open and closed bodies are black rubber, except where extremely light colors are desired, when they will be furnished in nickel. For special colored leathers a charge of \$25 is made.

### Motor Vehicles in Jamaica

American cars have won preference over all other foreign makes in Jamaica to such an extent that during 1915 fully 95 per cent of the total imports of cars and trucks and 80 per cent of the motorcycles came from the United States.

The latest official census gives a total of 833 cars and trucks, 70 motorcycles, and 15 traction engines in the island.

During the year 1909, when motor cars first began to become popular in Jamaica, the total imports of "carriages for pleasure, including motor cars," amounted to \$74,783. In 1910 the imports were valued at \$149,389, an increase of 100 per cent; and again in 1911 the imports amounted to \$207,543. There are no means of ascertaining just what

proportion of these figures is represented by motor cars alone, but if the figures for 1912 are taken as a basis of consideration the remarkable increases above noted may be attributed to motor cars.

Registration statistics do not segregate motor cars and motor trucks, but with a grand total of 833 vehicles it may be estimated that there are not more than 30 motor trucks (probably less) in the island, including those owned and operated by the government for mail transport.

There are no electric vehicles in use in Jamaica, and at present there appears to be no market for this class of vehicle. Steep grades, mountainous roads, and the lack of electricity on a commercial basis are factors that effectually operate against the introduction of electric vehicles into Jamaica.

### Predicts Metric Measurements Will Follow War

That the increase of exports due to the war will have a strong influence upon manufacturers of this country in adopting metric measurements is the opinion of R. L. Heising, chief engineer of the Moon Motor Car Co., St. Louis, Mo., which has experienced difficulty in the matter of mixing measurement systems.

"I predict that we will fall into the metric system, in order to meet the world-wide demand for American-made motor cars," says Heising. "My own company is developing a very large business in shipping cars to foreign countries, such as Spain, Norway, Sweden, the West Indies, and all of the South American countries. We find that our difficulty lies in the fact that unless we send parts to our agents in these countries, they are handicapped because miscellaneous parts needed by them, such as

nuts, bolts, etc., are all cut on the metric system, and they must have American parts because they cannot use the metric. The mechanics in these countries cannot even cut threads to fit American cars because all of their dies are metric."

### More Motor Truck Contracts Placed

In addition to the \$23,000,000 worth of motor trucks recently ordered for the War Department, orders have been placed for 5,750 vehicles at an aggregate cost of \$21,000,000, making about \$44,000,000 worth of army motor trucks now under contract. The quartermaster's depot in Chicago has also been advised to buy 192 light trucks of large chassis and Babcock delivery bodies for the army cantonments, 12 to be used in each place, the cost being \$750 each.

The Packard Motor Car Co., Detroit, received a contract for 3,000 trucks of three-tons capacity, of which 1,200 will cost \$3,197.39 each, and 1,800 will cost \$3,836.87 each. The Locomobile Co. of America, Bridgeport, Conn., received a contract for 1,250 trucks at \$4,071.38 each, and the Pierce-Arrow Motor Car Co., Buffalo, 1,500 trucks at \$3,500 each, all of 1½ tons capacity.

# Trimming a Limousine

Trimming is a branch in which there are many different ideas regarding designs, and also the quickest and most satisfactory ways of doing a job. Motor trimming is a work affording great scope for the taste of a workman. A car that is not properly trimmed will mar the well-finished work of the body maker and painter. In nine cases out of ten the trimming of a car goes a long way toward selling it, especially if it is nicely padded and well sprung. I propose giving a few hints, taking as my subject a closed-in car, such as a limousine.

For the back squab cut off a piece of canvas 6 in. deeper than the depth of the body inside at seat, and about 4 in. longer than its length. First, tack this on the bottom of the seat, allow 1 in. for tacking; draw your canvas up to the top of the seat, and fix it with a few tacks. Mark the pattern of the back on your canvas top and sides, the bottom is already marked. Tack out the canvas and lay it on your bench; draw it out straight, and with a few tacks here and there secure it from moving. Measure up your canvas and strike the center, A, Fig. 1. Draw up a straight line, A, allowing 1 in. at each end to allow for contraction when stuffed up. Measure 3 in. above the top line, and strike a line, B, which will be your top line, and will make sufficient allowance for the springs. You then begin to mark off the rows for your buttons. From the last line you made, mark down 7 in. to C, and then 4 in., D, and then 16 in. to E, reckoning that this back is 28 in. deep finished. This will leave 4 in. to the bottom, F, making in all 31 in., including the 3 in. allowed for the

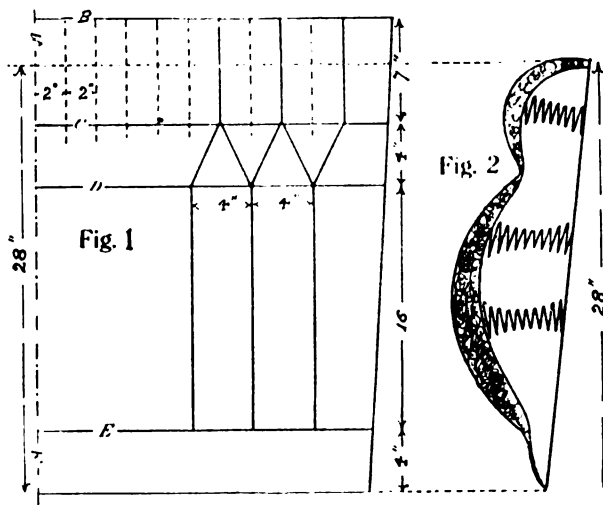

springs. Strike lines B, C, D and E across at all these marks.

We will also assume this back to be 44 in. across. To divide this up into 4 in. flutes, mark off along the top and bottom button lines 2 in. spaces on each side of center. Then with a straight edge and starting at the right, leaving a space of 4 in. from the ends, mark a line from the top line to the top button line. At this next mark strike a line from the middle button line down to the bottom, and so on alternately right across. Now fill

in your half-diamond by joining the top lines with the bottom lines, and stamp out your button marks with a small punch or a stout garnish awl. Fig. 1 explains this process.

## Cutting and Marking Out

To cut out your material, proceed on the same principle as for marking out, only using the fold of the cloth for the center. Mark out half the squab and stamp through, thus marking the two halves at once. Allow  $1\frac{5}{8}$  in. fullness across each flute, 3 in. at each end, and  $1\frac{1}{4}$  in. fullness in the swell, that is, between the bottom row of buttons and the middle row. Allow  $\frac{1}{2}$  in. fullness between the half diamond and allow 4 in. on the top and 1 in. at the bottom. This will make a nice comfortable squab with a big swell and a thick top sinking well in at the half-diamonds, as seen by the drawing, Fig. 2. If a flat squab is desired, allow  $1\frac{1}{4}$  in. across the flutes,  $\frac{1}{2}$  in. in the swell,  $\frac{1}{2}$  in. in the half-diamonds, and  $1\frac{1}{2}$  in. on the top. A medium squab can be got with  $1\frac{1}{2}$  fullness across the flutes, 1 in. in the swells, nothing in the half-diamonds, and  $2\frac{1}{2}$  in. on the top.

## Marking Out Morocco

In marking out morocco, the method is a little different. The best medium for marking this material is a black pencil such as is used by the leather merchants, and cut down to a chisel edge. This marks easily and very plainly, and is much better than a pencil. Lay out the skin on the bench with the tail end toward you; strike a line across this edge to make your top, and measure off 10 in., then  $3\frac{1}{2}$  in., then  $17\frac{1}{2}$  in., then 3 in. This allows 3 in. on the top, taking  $\frac{1}{2}$  in. out of the half-diamonds, with  $1\frac{1}{2}$  in. fullness in the swell and 1 in. on the bottom. Now from the left and along the top button line measure 7 in. from the edge of the skin; lay the square-board to this, then mark off on to the bottom button line; and from these two marks measure off 3 in. spaces. Lay the straight-edge at the first two marks, starting from the left; and strike a line from the top button line to the top line. At the next mark strike a line from the middle button line right to the bottom. Do this alternately across the skin and then mark in the half-diamonds by joining up these lines. Now lay this skin face to face on another one and stamp through the button holes, which will give you the two ends of the squab to be joined up, after seeing that the two halves pair to correspond with the canvas.

## Quarter Squabs

In making quarter squabs they have to be kept thin so that too much room is not taken up in the width of the body. When the canvas is fitted in the body for taking the size, mark off for  $3\frac{1}{2}$  in. flutes and half-diamonds  $3\frac{1}{2}$  in. deep, allowing for fullness 1 in. across flutes,  $\frac{1}{4}$  in. in half-diamonds vertically, and  $\frac{1}{4}$  in. between bottom row of buttons and middle row. This will make a squab of nice thickness, and not too thick. Fig. 3 illustrates the method of marking out. The fashion now is for quarters to be trimmed plain with an elbow fixed on.

Elbows are always fixed on when squab sides are used. Plain trimmed interiors have only the back squab, cushion and auxiliary seats stuffed with hair. For all other parts felt or wadding are used. This style is not only simple, but more quickly executed, besides meeting the desire for cleanliness.

The front squab is cut out on the same lines as above mentioned, only this cannot have a lot of swell, if any at all. Mark out to about  $3\frac{1}{2}$  in. or  $3\frac{3}{4}$  in. flutes, with half-diamonds of the same depth, allowing  $\frac{1}{4}$  in. fullness across the flutes and  $\frac{3}{8}$  in. in the half-diamonds vertically. This squab is often made with straight flutes, which are easier to clean.

### Stuffing and Finishing Squabs and Quarters

The stuffing of squabs can be done in two ways, either by nailing to the bench or on a frame. If the former method is used, the ends of the back squabs and back ends of quarters should first be sewn up, and either bound with a piece of pasting lace, or have a piece of seaming lace sewn on. This, however, is only necessary for the back squab. Lay your canvas on the bench, the linen on top, then the wadding, then the material, all pleats having been sewn by machine, as this makes them form better. Then put in all the buttons, sew up and bind the ends, nail out on the bench, and stuff, with the bottom toward the workman, leaving the top part of the half-diamonds till the last, if it is desired to stuff these when the squab is in the body. But if the squab is to be stuffed on a frame, stretch the canvas on the frame, and after putting in the two top rows of buttons, stuff the half-diamonds; then put the bottom row of buttons in and stuff up the swell, afterward arranging the ends to suit the swell of the squab before sewing up and binding.

Now turn the squab over and sew on a strip of canvas about 4 in. wide at the back of the half-diamonds, just at the top row of buttons. This is to be sewn strongly with twine. This squab is intended to have three rows of springs, viz., two rows of long springs in the swell, about 7 in. long, and one row of 3 in. at the top above the half-diamonds. When these are fixed, put in your squab, securing it firmly at the bottom, and nail to the back board the piece of canvas you have sewn on the back, so that the back canvas stands out 3 in. from the board in Fig. 2. This gives the squab nice free play. Pull up the top and nail in. Then stuff up and finish off. This gives a squab of complete comfort fitting into the occupant's back and affording easy riding.

The quarters can be stuffed up on the bench and finished off in the body; so also can the front seat squab. The quarters of the front seat can either be stuffed or plain, but if the front seat has only one squab all around care must be taken with the corners, not to have them too full.

### Trimming of Doors

In the making of doors there are very many different methods. The door is a thing which, if not done well, will always be an eyesore. I will endeavor to explain the trimming of a few doors of simple design, yet good and commanding attention.

The first door (Fig. 4) can be done in two styles, namely, stuffed with hair or done with a thick felt and wadding. In doing it with hair, first fix your pasting lace all around the door. Then mark up from the bottom of the door for the carpet. Now nail on the broad lace, with the tape

to finish under the pasting lace. Now draw a pencil line around the inside edge of the broad lace. Measure off a piece of material  $1\frac{1}{2}$  in. larger all round than the size of the space between the laces. That makes about 3 in. each way. Now measure off a piece of linen and wadding; lay the linen on the bench, then the wadding, and then the material on top. Paste all round the edges; next fix them on the door with a tack at each corner. Measure off two pieces of cord the length required, measuring from corner to corner. Fix the cords on the door, straining them across the doors from corner to corner. Nail the

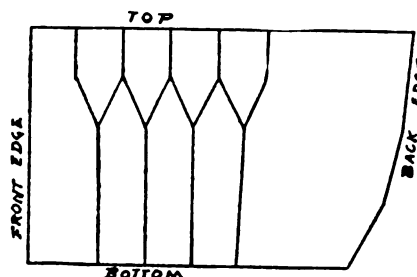

Fig. 3

cord securely under the broad lace and also in the center of the door where the laces cross one another. The tighter the cords are pulled the better it is for the trimmer. Now stuff up evenly with horse hair. Do not let any hair get under the cords if possible, but fill up each division a little at a time, until all divisions are evenly stuffed up. Next proceed to finish off one division at a time, easing the material in at the edges, so that it stands up bold. Finally, fix the rosette in the center. This makes a nice door and catches the eye very quickly.

In doing the same door with thick felt paste a piece of canvas across the door where the pad is to be made up, but allowing it a bit bigger all round. Fix on the laces as before and let the paste dry. Mark the pencil line around the inside edge of broad lace, and also two lines across the door from corner to corner. Fit pieces of felt 1 in. thick and a shade smaller than each of the four spaces. Before fixing the felt spread rubber solution along the cross lines to a width of about 1 in. and also around the edge lines. Solution the material in the same way and lay it by to dry. Fix the pieces of felt with paste, putting the paste on the felt and lay a piece of wadding on each section. Take care not to cut the wadding as large as the felt, or it will get in between the crevices of the felt and prevent the material from sticking. When your solutioned material is just tacky for sticking, cut a small hole about  $\frac{3}{4}$  in. in diameter, out of the center of material. sew the edge of the hole round with a running thread, and secure after pulling up tight. This makes a series of wrinkles, which will afford sufficient fullness to allow the material to go down between the felt, without dragging. Fix in the center with a tack, lay the material in the crevices between the felt and rub it well to make sure it sticks. It is necessary to see that the center points are neat and have no wrinkles. After this the cords may be strained tight across the doors. Finish off the edges and corners, fix the boards under the broad lace, and fix the lace down, and then fix the rosette in the center. This makes a very attractive door if neatly done.

The next door, Fig. 5, is a pattern with a pocket and squab. To make up, fix a piece of buckram canvas inside the broad lace and mark around the edge of the lace.

Take off and lay on the bench, to mark off the size of pocket and pad. Supposing the door to be 2 ft.  $2\frac{1}{2}$  in. wide, the size inside the marks on the canvas will be  $19\frac{1}{2}$  in. across and  $18\frac{1}{4}$  in. deep. Strike a line down the center, measuring  $6\frac{1}{2}$  in. each side of the center line, and then another  $\frac{1}{4}$  in. for the seaming lace. From the top measure down 11 in., then  $\frac{1}{4}$  in. below that, drawing lines to these marks. This will give the size of pocket and flap, with a seaming lace around the sides and bottom. A space of 3 in. is left at the side and 7 in. at the bottom. Divide the length between the top of pocket and top of pad into four, and mark short lines on each side of the pocket, to mark the pleats. Next mark out the bottom pad by dividing across the width of the pocket into four equal parts. Square off lines from top to bottom. Just under the pad draw a line through the center of the upright lines and cross your lines to form the diamonds. You now have your pocket and flap and pad complete. Now start to make up pocket. Cut out a piece of buckram canvas the size of the flap. By marking round the edge of a penny or similar coin you can get the exact curve for

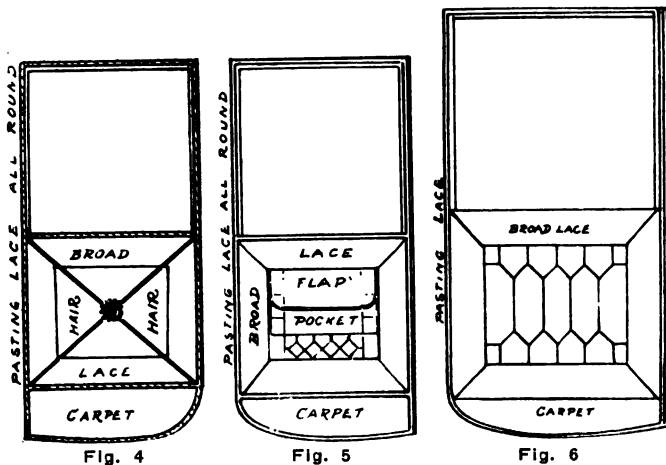

both corners. Also cut another piece the size and shape of the pocket for the flap. Cut one piece of material 1 in. longer than the canvas along the top, and the other piece 1 in. larger all round. For the inside of the pocket, cut a piece the exact size of the canvas and another piece allowing  $2\frac{3}{4}$  in. on sides and bottom to allow for a gusset and 1 in. around the top edge for the turn over. Make the gusset 1 in. deep. For cloth it is better to be stitched and pressed with a hot iron, but if leather or morocco is used creasing will do. Stitch gusset on to the pocket and then on to the mark on the canvas the size of the pocket. Cut out the corners of gusset and stitch neatly together, and then press them to flatten them out nice and true. Now cut and fit up side pieces, that is, the pleats, allowing  $\frac{3}{4}$  in. fullness for each space and a little extra for the end ones. To mark out the pad on bottom of pocket, allow  $\frac{5}{8}$  in. across the diamonds and  $\frac{1}{2}$  in. top to bottom, and about 1 in. on top and bottom edge of material. Make all pleats and button and stuff up. Everything is now ready to fix on the door. First lay a piece of wadding in the space marked for the pocket and cover with a piece of material 1 in. larger all round. Baste the material to the canvas, keeping it taut all the time. Now fix the pocket and flap in their places. Baste a piece of seaming round the sides and bottom, taking care to keep the corners square. Then sew the material for the squab part into the seaming lace with good thread and fix the

pleats as you go along. Put in the buttons and nail on the door, and stuff up and finish under broad lace, the same as in door in Fig. 3.—Australasian Coachbuilder and Wheelwright.

### Germany's Motor Industry

Once more the Germans are reviewing the financial condition of their motor industry during another year of war. The Daimler-Mercedes, with 8,000,000 marks capital, has doubled its pre-war profit (3,214,168 marks), the profits in the last working year being 6,620,104 marks—over 80 per cent on the capital employed. During all this time the dividends have risen, starting from 14, proceeding to 16, and then to 25 per cent. How the Germans view their industries is incidentally revealed by the fact that the quotation for the shares is practically a reflection of the profits, having been 328 marks per 100 mark share the year before the war, and 630 marks at the end of last year. German policy, of course, aims at enabling their manufacturing enterprises to put themselves in as strong a financial position as possible during the war instead of subjecting them to excess profits duty to the extent that obtains in this country.

It is not generally known here that the Benz firm is a much larger enterprise than the Daimler-Mercedes, but, as a matter of fact, it has a capital of 22,000,000 marks. The magnitude of the Benz concern is due in a large measure to amalgamations. Though possessing nearly three times the amount of capital that suffices for the Daimler, the Benz firm is today making only half the profits, and only two-fifths of the profits made in the pre-war year. On the other hand, the greatest profits so far returned by any of the German motor enterprises was secured in 1914 by the Benz—8,898,549 marks, against 5,012,644 marks in 1913, and 3,019,466 marks in 1915. In spite of this striking diminution of profits, the dividend has risen from 10 per cent in 1913 to 20 per cent in the last financial year; and the price of the 100 mark shares from 141.5 marks when the war broke out to 280 marks at the end of 1916.

The third large German motor manufacturing enterprise is the Adler, which has 13,000,000 marks capital. Its profits show a distinct increase on the pre-war period, though its dividends have gone down. The figures for 1913 were 4,191,327 marks, when a dividend of 25 per cent was paid, against 5,598,481 marks for the last completed financial year, and a 22 per cent dividend. The price of the 100 mark shares when the war broke out was 250 marks, and is today 350 marks. The general conclusion to draw from this and from the case of the three next most important motor manufacturing firms in Germany is that the majority of them are conserving their financial resources, and building up very strong positions for the post-war period.—H. Massac Buist, in London Post.

### Tuthill Spring Co. Is Oversold

The Tuthill Spring Co., Chicago, Ill., has so many orders on hand for truck and pleasure car springs that it will not accept any more contracts for 1917. A total of 52 fuel oil furnaces are now being operated at full time in the forging and heat treating departments. Owing to the excessive price of fuel oils the company has been conducting a series of experiments on a new type of gas furnace, which so far indicates more perfect combustion at lower cost than has heretofore been possible.

**Single Seat Body, Bucket Type**

This body is made on ordinary V lines, excepting the scuttle, which is round. The bottom frame is blocked up to rise on chassis over hind axle as follows: Framing runs right through outside, being shaped to plan. It is cut away to fit rise, still running straight on the inside; a block is fitted on top of framing to cover rise, and cleaned off on the outside to side bevel. Back bar is halved on to side framing and rounded to plan. On extreme tail of boot is fitted a 3 in. block (pine for preference) cleaned off to meet round on both sides and top of boot. To this block is fixed elbow rails and center rail, thus giving desired sweep of body. Across back of seat is framing V type rail, which is halved on to pillars, thus giving lines on the widest part of the body. Between V type rail and block on end of boot are two or three cross frames and pillars to give desired strength.

wide enough to admit carrying spare wheel.—Australasian Coachbuilder and Wheelwright.

**Natural Wood Finish for the Car Interior**

The natural wood finish found in the car interior today represents a bit of the finest class of work in wood finishing. It demands a grade of skill second to none. That its popularity is to increase there is abundant evidence. That it is to furnish the men capable of doing it a source of profitable revenue is also evident. Taken by and long, then, it is surely worth the thought and attention of all engaged in the repainting business.

The first process of importance in the natural wood finishing art consists in filling the wood. The choice of a filler is one step; this should be a mineral paste filler for all open-grained woods such as, for example, walnut, mahogany, oak, chestnut, ash, etc. Cherry, maple, birch,

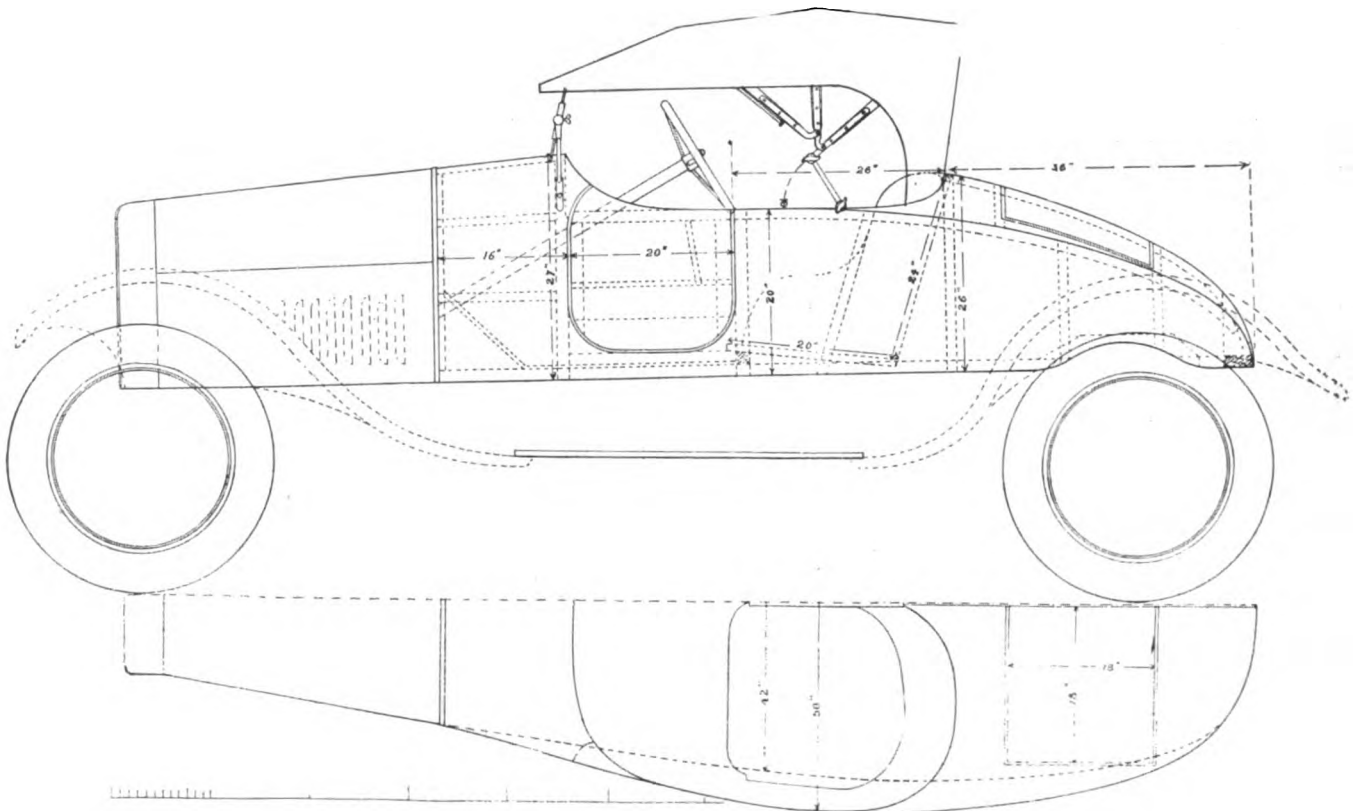

Elbow rails are fitted on to shut pillars. These elbow rails run from shut pillar to block on tail, and they give desired sweep on one side. Round on corners of seat is made by fitting in 9 in. bent round corners, which are finished by fitting a block in center to desired shape and size of bucket. Scuttle and doors are framed up in the ordinary way. As this body is made for lightness, either 24 gauge iron can be fitted all through, or 24 gauge iron on scuttle and three-ply wood on side quarters and on top of boot. Panels are turned under on bottom, side panels being put on first, boot tops next and turned over on edge, a 1/2 holding being fitted on elbow edges.

Boot lid is made in ordinary way, but only on side for preference and accessibility, etc. A dicky seat can be very easily fitted if desired. A small frameless screen is fitted and the top is made with movable arms to make top lie down as forward as possible, thus making the body look more compact, etc. If desired the boot lid could be made

beech, etc., are called close-grained woods, but personally we prefer to use a paste filler for the beech, and cherry, and some of the samples of maple. There is never any danger of overfilling the wood, and very great danger of insufficiently filling it, and for this reason we choose, as a rule, to use a paste filler and choke up any vestige of open grain. The liquid elements will serve to filter into the close grain, and work in the nature of a liquid filler, which gives the paste filler additional value in this work. The mineral paste filler made up of atoms of silex ground into needle-shaped fragments capable of extreme penetration furnish the best material for filling the wood. This filler is nonbleaching, indestructible, stays in place, and fills the wood.

Perhaps the most economical way to buy the filler, when it is not extensively used, is in the ready-to-use form—that is, mixed ready to be stirred into a consistency for application. If shop mixed of the raw material use the



following proportions: Any given quantity of, say, No. 1 silex, mixed thoroughly in equal parts of raw linseed oil, pale drying japan, and turpentine. Such a filler should dry or set up for wiping across the grain in about 20 or 25 minutes. Use for wiping a ball of tow, or cotton waste. Apply the filler with a partly worn brush, and as soon as it begins to take on a dry or dead appearance proceed to wipe it in and across the grain of the wood in a manner to fill up the cells and grain. After completing the filling process stand the surface aside over night to allow the filler to become fully dry before working over it.

Directly over the filler apply a couple of coats of orange gum shellac. For inside work nothing equals shellac for quick and sure sealing up of the pores, and fetching the surface out round and solid and compact for the varnish. The shelac is quicker in its action than any other known material, bodies up promptly, and holds out the varnish to the best possible extent. Use a shellac cut with a first class denatured alcohol so that in working over large panels the shellac may be brushed freely without roughing or piling up on the surface. For good work anywhere from three to six or more coats of varnish will be needed to develop the body to rub and polish on.

For all surfaces to be polished bring the coats along in rubbing varnish as usual to the final coat which should be a straight polishing varnish. For good work all the way long sandpaper the first coat of varnish; then with pumice stone and water rub the others keeping the surface clean and free from dirt nibs, runs, etc., so that when the last coat is reached, whether rubbing or polishing varnish, the surface shows fine and full and amply rounded out. For a simple dull varnish finish omit the polishing varnish; rub the varnish with water and pumice stone flour to a flat, lustreless condition, and then wipe to a semi-lustre with some good varnish renovator; if preferred, take some rotten stone and dipping the rubbing pad in this, and then in sweet oil, bring out the degree of gloss desired by a smart rubbing. When polishing varnish has been used catch off the outer lustre with water and pumice stone flour, and then with a ball of raw cotton dipped in the polishing mixture proceed by rubbing with a rotary motion which, as friction develops, the high, sharp polish comes out. Polishing is performed by means of friction; when the rubbing or polishing ball of cotton creaks and snaps dryly the polishing is proceeding finely. Hard pressure—elbow grease it used to be termed—is required to develop this friction. The advantage of the polished surface is that it can be handled without marring or soiling the finish, and the high lustre stays on the surface. For the interior of the car this is an important feature, and one which the owner or user will appreciate.

In all natural wood finishing it will be necessary to keep the wood clean and free from stains, finger marks, and discolorations; this is an indispensable need, at least until the shellac coats have been put in place and the raw wood surface protected from contact with the air, hands, and other mediums which prove destructive to the appearance of the work. Woods which require filling also often require certain wood effects obtained only through first staining the wood. When this is done the filler is then stained with the balance of the stain. In this manner the effects are harmonized. The stains consist of three kinds, to wit: Oil stains, acid stains, and aniline stains. The aniline stains are made from a coal tar base and have

the reputation of bleeding out under varnish. The oil stains are made by reducing pigments with oil, turpentine and other thinners. These stains retain their color durably, but from their use the true wood tint is rarely developed. Moreover, these stains lack the depth and brilliancy of the acid or aniline stains.

The point may be made that while the aniline stains produce, if anything, too brilliant effects the oil stains produce an insufficient amount of such effects. Acid stains are principally used in finishing woods employed in the interior construction of automobiles. They raise the grain of the wood to some extent, but this may be prevented very largely by first sponging the wood with cold water. Then when the surface is dry proceed to sandpaper it with fine sandpaper before staining. The acid stains are preferred by expert wood finishers because they produce clean, beautiful wood tone and effects. The raising of the grain is said by these finishers to be an advantage in that it brings out certain details of the wood effects which otherwise would not be disclosed. When the paste filler is to be used without having the wood previously stained, and, for example, mahogany is the wood to be filled, a little burnt sienna should be stirred in to give the tone and color to the filler. For black walnut use burnt umber. Mahogany can be given a fine touch of brilliancy by adding a touch of Bismarck brown. For antique mahogany use a reduced golden oak stain.

In staining the wood the essential point needs to be kept in mind, namely, that the object of staining is to emphasize and add to the natural beauty of the timber. Of course, time itself is the most wonderful stainer; in some woods it produces incomparably fine effects. Oak, for example, under the touch of time, becomes almost black of a most splendid brilliancy; mahogany takes on a magnificent deep red tone, maple a deep buff brown, etc. One word in concluding: Use for all this class of work the best obtainable stock, fillers, stains, shellac, varnish, oils, turpentine, etc. They are the basic things in wood finishing.

---

### Ford Accessory Exhibition

The National Exposition for Ford Accessories has been incorporated and will hold a show in the Chicago Coliseum, September 22-29, which will be devoted exclusively to the display and demonstration of accessories, equipment and attachments for Ford cars.

The management is already assured of upward of 250 exhibitors, who will occupy all the main floor of the Coliseum. The Annex will be used for demonstrations and automobile college exhibits, lectures and motion pictures featuring the industry. 500,000 tickets, distributed through accessory dealers in the 13 states of the middle west, will be given to owners of Ford cars.

Officers of the exposition are: President, J. E. Duffield, treasurer and general manager of the Bailey Non-Stall Differential Corp., Chicago; first vice-president, Charles Johnson, general manager of the Maltby Auto Specialty Co., Detroit; second vice-president, H. S. Irving, vice-president of the Advance Automobile Accessories Corp., Chicago; secretary, W. Ralph, manager of News-about Fords, Chicago; treasurer, B. L. Gray, president of the Gray-Heath Co., Chicago; general manager, H. V. Buelow, Toledo, O.

### Co-operation With the Spring Maker

By E. B. Flanigan\*

There can be no doubt that a major portion of the suspension troubles of a great many truck builders could be avoided if there were more co-operation with the spring manufacturers. In a great many cases the designer of the springs has little or no information as to the type of vehicle he is working on. It very often happens that the designer imagines that he has the data for a light worm-drive truck taking the drive through the springs when, in fact, the springs he designs are used on a trailer, and

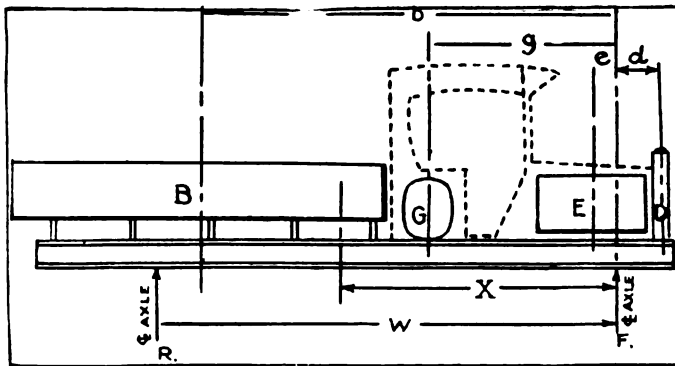

Fig. 1

on which an entirely different spring may be used. This necessitates needless correspondence, and then, in some cases, incomplete data. If the spring maker has a fair amount of information he can very easily design a satisfactory arrangement. It seems very unfortunate that the spring designer in so many cases is left in the dark.

If the truck is only laid out on paper considerable valuable information can be given to the spring maker.

In the preliminary design the maximum and minimum lengths of both front and rear springs may be decided on, and the maximum width of the springs. It is also necessary at this time to determine the loaded heights of the springs. Probably the best arrangement would be to so design the chassis that the springs, particularly the rears, ride flat or with no camber with the full rated load on the truck. This is to be advised not only because a flat spring gives a more satisfactory suspension (particularly when the springs are driven through), but also it is a warning to the truck owner when the truck is overloaded. The average truck operator will hesitate to load a truck to a point where the spring begins to reverse its camber.

The next question to be determined is the size of the end bolts. If the springs are not driven through these bolts may be the same size at both ends. On a worm drive job, on the rear springs, it is customary to make the bolt larger to reduce the bearing pressure due to the drive and enable the bolt to be well lubricated. This bolt, however, must not be made an excessive size, as it calls for a large eye rolled up from the main plate. If this eye is too large there is danger of eye breakage or of the eye opening up. The bolts on both ends of the front springs may be the same diameter. In deciding the sizes of the end bolts the S. A. E. standards, or the spring makers may be consulted.

(a) Load on Springs—The next and most important consideration is the weight coming on front and rear

springs. Suppose the job is just laid out on paper as in Fig. 1.

Let B = Weight of empty body.

G = Weight of filled tank.

E = Weight of engine.

D = Weight of radiator.

X = Weight of frame.

R = Proportional weight of above that comes on rear springs.

F = Proportional weight of above that comes on front springs.

b = Distribution from center of gravity of body to center line of front axle.

g = Distribution from center of gravity of tank.

e = Distribution from center of gravity of engine.

d = Distribution from center of gravity of radiator.

x = Distribution from center of gravity of frame.

w = Length of wheelbase.

Now, if we take moment about the center line of the front axle

$$Rw = Bb + Gg - Dd + Ee + Xx, \text{ or}$$

$$R = \frac{Bb + Gg - Dd + Ee + Xx}{w}$$

Then,  $F = (B + G + D + E + X) - R$ .

In this way the weights on the front and rear end may quite readily be determined for the truck without the payload. Any other parts of the truck may be very easily added to the above computations.

If a truck is partially built the values F and R may be determined directly by platform scales placed at the axle centers. Also, if a truck is entirely finished, it may be run on scales and the front end and rear end weighed. Subtract from these weights the weights of wheels and axles at each end, or in other words, the unsprung weights, and the values F and R are obtained again.

(b) Load on Springs—(Pay Load). Having obtained

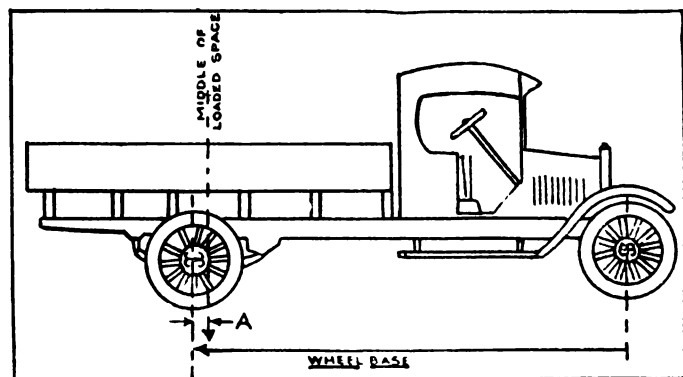

Fig. 2

the above data, it is very easy to determine the pay load on the springs. In Fig. 2 we see the finished truck.

Suspend a plumb bob from the center of the body and measure the distance "A" to the center of the rear axle. This may also be done on the drawing. (Fig. 1.) Then

$$\text{the proportion of pay load on rear springs} = \frac{w - A}{w}$$

(c) Load on Springs—The load on springs will then be the sum of the loads F and R, and the load due to the pay load.

Clearance—The clearance is another item that is very

\*Spring engineering department, Sheldon Axle and Spring Co., in Motor Truck.

important to the spring designer, as this influences the flexibility that can be given to a spring. The maximum amount that a spring may deflect below its position with the full rated load on the truck should be given.

Data to Send to Spring Maker—The thickness of the spring at the center, as well as the number of plates should be left to the spring designer to determine. It would be well to fill out a form similar to that given below. If the widths and lengths of the springs have been determined on these should be given in the place of limits. It should be remembered, however, that the longer the spring the more flexibility may be given to it for the same stress in the steel. Also that the wider the spring the stronger the spring eyes at the end will be.

#### Truck Manufacturer

Rated capacity of truck.  
 Model number of truck.  
 Speed of truck.  
 Wheelbase.  
 Spring material.  
 Maximum length of front spring.  
 Minimum length of front spring.  
 Maximum length of rear spring.  
 Minimum length of rear spring.  
 Maximum width of front spring.  
 Minimum width of front spring.  
 Maximum width of rear spring.  
 Minimum width of rear spring.  
 Diameter of end bolt on front end of rear spring.  
 Diameter of end bolt on rear end of rear spring.  
 Diameter of end bolt on front end of front spring.  
 Diameter of end bolt on rear end of front spring.  
 Load on each rear spring truck empty.  
 Load on each front spring truck empty.  
 Load on each front spring with full rated load on truck.  
 Load on each rear spring with full rated load on truck.  
 Height of front spring under full rated load. (Outside height if overslung, open height if underslung.)  
 Height of rear spring under full rated load. (Outside height if overslung, open height if underslung.)  
 Clearance front end.  
 Clearance rear end.  
 Part number of front springs.  
 Part number of rear springs.  
 Do the rear springs take drive?  
 Do the rear springs take torque?  
 Minimum distance from center of eye to rebound clips.  
 If the data given above were given to the spring maker there is absolutely no reason why the truck builder would not have just the spring desired, and all misunderstanding would be entirely eliminated.

#### How the Upholstery Question Is Being Settled

While not a new subject, one that is receiving a great deal of consideration from the builders of railway and steam cars is upholstery. Prices of construction materials are constantly advancing, and upholstery is one of the top notchers. The increasing shortage of hides is the chief cause. Large users of leather are being forced to other markets for material to take its place. Leather substitutes are coming into more general use every day.

The upholstery end of the railway business is receiving particular attention. For years most all upholstering was

of plush. A few years ago leather was given a trial. To meet the demand for economy, the leather manufacturer was forced to make rock bottom prices. He soon found that these prices wouldn't pay for the best leather, and eventually the car builders were being supplied with split leather instead of grain leather. This at first answered the purpose, but it did not take long for it to crack and peel.

Cane upholstery was also tried, but like plush, it wasn't vermin-proof, nor sanitary. Dust and dirt stuck to it.

Leather substitutes have now come to the front and are proving satisfactory, especially for smoking cars, and cars on roads using soft coal. A high grade leather substitute is stronger than split leather because the latter is merely a sectional sheet of a hide surfaced with practically the same coating that is used to coat the substitute, and embossed in the same way. It is uniform in thickness, comes to the purchaser in a roll and thus eliminates waste in cutting it; it is waterproof and washable, and in the better grades, is guaranteed superior to split leather.

The fact that it is waterproof puts it far above other upholstery. While it will not hold dust like plush or cane, it naturally gets dirty, but can easily be cleaned with a wet cloth.

Double texture artificial leather used for curtains will stand both hottest and coldest weather. If the rain happens to beat in the window, its waterproof qualities prevent damage, and its embossing is not hurt by sun heat. As it is not affected by heat, the warmth of the car in winter will not injure it.

High grade leather substitutes answers the economy question by being much cheaper than any other guaranteed upholstery.

With the progress being made in the manufacture of leather substitutes and the fact that the material is cheaper than any other upholstery it certainly looks as if it had made its mark in the industrial and mercantile world. Other grades are used for upholstering household furniture and automobiles, as well as bookbinding.

#### Wisconsin Has Another Sleigh Law

The Wisconsin legislature again has enacted a so-called "wide sleigh" law which will go into actual effect on January 1, 1919. The legislature of 1913 passed such a law, but it was repealed by the 1915 session. The new law reads as follows:

"On and after the first day of January, 1919, it shall be unlawful for any person, firm or corporation in this state to sell any new or first-hand draft sleigh, No. 5 and upwards, manufactured after said date, to any person or persons residing in this state for use herein, unless the runners of such sleigh shall measure from center to center 4 feet and 6 inches. And on and after such date it shall be unlawful for any person or persons to use upon any of the public highways of this state any such sleigh, purchased at first hand after said first day of January, 1919, unless the runners shall measure from center to center 4 feet and 6 inches.

"Any person, firm or corporation violating any of the provisions of this section shall be guilty of a misdemeanor and upon conviction thereof shall be fined not less than \$5 nor more than \$25."

## Government to Ask for Ordnance Truck Body Bids

The ordnance branch of the army is preparing to buy considerable quantities of ammunition bodies for three-ton and five-ton trucks, and also supply and repair trucks. Specifications for these are now completed and Major Moody, in charge of the work, expects soon to ask for bids.

The first bids will call for about 1,000 ammunition bodies, probably 700 supply trucks and 500 repair types. Exceptionally substantial construction will be required of the supply and repair trucks, as they will be called on in service to carry a load of from 4,000 to 5,000 lbs.

Standard specifications for these motor truck ammunition bodies as approved by the Chief of Ordnance follow:

### General Conditions

1. **Quality of Materials**—Except it be otherwise specified, all materials are to be the best of their respective kinds, and all labor is to be done in the most thorough and workmanlike manner. In all cases where an article is mentioned in these specifications in connection with the words "best quality," "best make," "proper," or "suitable," the ordnance department or its authorized representative shall decide what is best and most suitable to use.

2. **Award of Contract**—The bodies herein specified are to be used in the field service of the ordnance department, and in the selection of bodies and award of contract, the quality of material, design, workmanship, and suitability for use in field service will be given due weight in determining which proposal shall be accepted.

3. **Employment of Convict Labor**—In the performance of work herein specified, the contractor shall not directly or indirectly employ any person undergoing sentence of imprisonment at hard labor which may have been imposed by a court of any state, territory or municipality having jurisdiction, nor permit such employment by any person furnishing labor or material to said contractor in fulfillment of this agreement.

4. **Patents**—The contractor shall for all time secure to the government the free and undisputed right to use any and all patented articles used in the work, and shall defend at his own expense any and all suits for infringement of any patent or patents, and in case of adverse claims under patents, the contractor shall pay all awards.

### Description

5. **General Requirements**—These specifications contemplate the furnishing, f.o.b. factory, of the number of bodies stated in the "Instruction to Bidders." The bodies shall be complete in every respect, and ready for installation on the chassis frame. It is intended that these bodies shall be so constructed as to permit of their installation on any chassis frame irrespective of the width or height of frame, and at the same time permit of ready access to the transmission and rear axle, and to give a proper clearance between the rear wheels and truck body when the truck is fully loaded. The body shall be constructed in accordance with details shown on drawings, Nos. 00.

6. **Material**—The entire body, sides, end and rear doors are to be made of No. 10 flange steel commercial or best quality No. 10 hot rolled, smooth finish, medium temper steel of 0.5 to 0.15 carbon; 0.10 desired.

7. All iron or steel used in construction of bodies must be free from rust, corrosion or pitting, and must not be bent or warped. Where malleable castings are used they must be thoroughly annealed. The special body parts shown on the drawings, including fastening brackets of body to chassis, hinges and hinge butts must be made of forged steel.

8. The body shall be reinforced at proper intervals as shown in sketch "No. B," July 14, 1917, with 3 in. 4-lb. standard steel channels thoroughly fastened to the body with hot 7/16 in. rivets. All holes in the body shall be 1/32 in. larger in diameter than rivets, and will be punched and reamed.

9. All parts of the body must be connected by 7/16 in. hot rivets. Fastening brackets of body to chassis will be riveted to body with hot 7/16 in. rivets.

10. All steel floor plates, loading plate, body side and end top angles or channel, and all other steel strips or sections shall be in continuous lengths. No piecing of these parts will be permitted.

11. Brackets for securing various implements to body will be installed in such locations as shown by drawing and will conform to drawing Nos. 00.

### Covers

12. **Materials**—The body covers must be of best quality No. 6 standard cotton duck, made from American cotton, woven in a workmanship manner and free from imperfections, thoroughly brushed to remove motes or other foreign substances, and must be waterproofed. No pieced lengths will be allowed.

13. The covers must have grommets worked over 5/8 in. galvanized rings. Ropes to be 3/8 in. of best quality manila. All side ropes to be neatly spliced into grommets, all face ends to be well whipped with well waxed thread.

14. **Lettering**—All covers must be stenciled in two places with "U. S." with 6 in. black doric letters, and "ORD." and "DEPT." with 4 in. black doric letters, the whole to be arranged symmetrically, as shown in drawing.

15. **General Provisions**—The covers must be made in accordance with the dimensions shown on drawings. All work to be done in the best workmanlike manner. Covers to be subject to the usual inspection.

16. **Painting**—The bodies must be painted all over, as per drawing 27-26-1 (prints of which specifications will be sent on request), each coat of paint being permitted to thoroughly dry before applying the succeeding coat.

17. All iron and steel must be given one good coat of lead and oil, and permitted to thoroughly dry before assembling.

## Willys-Overland Controls Curtiss Co.

Arrangements have been completed by which the Willys-Overland Co. assumes virtual control of the Curtiss Aeroplane and Motors Co. The two companies have been practically allied ever since the formation of the Curtiss company in January, 1916, and it now has the same officials and board of directors as the Willys-Overland Co.

All the stock in the Curtiss company is held in a voting trust. By action of the board of directors of the Willys-Overland company a considerable block of Curtiss stock was purchased for the treasury of the Willys-Overland company, and at the same time C. M. Keys, of New York, resigned as one of the three voting trustees. James E. Kepperley, vice-president of the Willys-Overland company, was immediately elected to succeed him, thus giving the Willys-Overland company two of the three trustees and making their control complete for all practical purposes.

The Curtiss company was formed to take over the airplane and motor business of Glenn H. Curtiss, who assigned his patents to it upon its formation. A month after its formation it also acquired the capital stock of the Burgess Aeroplane Co., of Marblehead, Mass. Besides the Burgess factory, it operates the original Curtiss plant at Hammondsport, N. Y., and factories at Buffalo and Toronto.

## Nebraska Leads in Motor Cars

Nebraska has one automobile for every 9.25 persons and therefore heads the list of states in per capita ownership of motor cars. The secretary of state of Nebraska had issued 129,000 automobile registration certificates up to July 16, the state's population being given as 1,192,214

## Paint and Varnish

### Two Famous Blues

Prussian blue among the many blue pigments deserves first notice, largely because it is most extensively used in painting and decorating. It has many virtues and at least two serious faults, but both virtues and defects are also to be found in the other blue pigments, so a knowledge of the properties and peculiarities of each is invaluable to the best use of the blues. The coloring strength of prussian blue is truly remarkable. One pound of it will tint 2,000 lbs. of white lead to a sky-blue color.

Prussian blue is so fine that it may be thinned greatly; it absorbs an enormous amount of linseed oil and at the same time possesses very great covering capacity. It is of the clear, transparent blue color that is so acceptable to the interior decorator for glazing.

When used with an understanding of its shortcomings it produces tints that are fairly permanent in strong light, such as for porch ceilings, but prussian blue does not compare at all favorably from the viewpoint of permanency with such earth pigments as the umbers and siennas. It is satisfactory largely because there is nothing better to take its place. Ultramarine blue is quite permanent in sunlight and a more beautiful blue color, but because it contains sulphur, which may darken the white lead base of paint, its use is limited to interior decorating of ornaments and panels where zinc may be used as the white base.

The permanence of prussian blue tints is affected by alkalis. They fade quickly when they come in contact with the lime of new plaster walls which have not yet lost their causticity. When mixed for distemper or water paints with whiting or asbestine base which contains alkali, prussian blue takes on a reddish tinge.

Two grades of this color are found on the market. The better quality is very clear and transparent. Its unusual covering power is easily noticeable. The second quality is just about worthless for tinting, as it produces muddy colors of a purplish, dirty blue-black tone.

Prussian blue is sold under many proprietary and trade names, such as Paris, Chinese, Antwerp, Berlin, Brunswick, Celestial, Bronze, Steel, Reflex, and Night Blue. Each product, however, is prussian blue in one form or another, more or less extended, or changed in tone by the addition of other substances. Very little chemically pure prussian blue is used by the painting trade. The extended article is the product commonly known. It is ground in linseed oil, japan, varnish, and water.

The manufacturing process by which prussian blue is produced is quite simple. Commercial potash is fused in large vats with animal blood or other animal refuse, and the resulting product is prussiate of potash of a yellow color.

The prussiate of potash is added to a solution of two parts of alum and one part of sulphate of iron. Prussiate of iron and alumina are precipitated or thrown down to the bottom of the vats in an intimate mixture, and after washing, drying, and grinding are ready for the market as prussian blue.

Chinese blue is the name given to a very fine grade of prussian blue, having a better lustre and clearer tone than the ordinary product. Prussian blue that is soluble in water is also designated by the same name.

Ultramarine blue is of quite ancient origin, having first been extracted from a semi-precious stone bearing the name "lapis lazuli" and worth 5s. an ounce. The stone is usually found in the form of pebbles with iron pyrites, limestone, and rock formation in China, Thibet, Persia, Siberia, and in the Andes Mountains of South America. While being made only by this natural process the cost was too great to permit of any extended use, and today it has but a limited use among artists.

Chemists, however, revealed the composition of the precious stone, and since then ultramarine blue has been made artificially at low cost. The pigment produced from the stone is coarse in texture and not so clear and brilliant in tone as that produced artificially. Ground in oil, the artificial product is more opaque and possesses greater tinting strength.

Ultramarine blue may be made very opaque to cover well or quite transparent for glazing by changing the base material by which it is ground. It is made in many shades from a clear, real blue to reddish tones of blue near to purple; the former, of course, is more valuable. Certain kinds of ultramarine have a greenish cast.

The tinting strength and covering capacity of ultramarine are not nearly so great as of prussian blue, but it is a satisfactory pigment from this standpoint. Ultramarine blue is permanent in sunlight, is not affected by lime, alkalis, or sulphuretted hydrogen. It is, however, adversely affected by vinegar and other pigments or colors containing acetic acid.

Ultramarine can be so carefully made that it may be successfully used with white-lead paint, but the ordinary commercial grades are not satisfactory for tinting because the sulphur contained may change the lead carbonate to lead sulphide, which latter is black, and thus cause the paint to dark in tone. This blue is ground in linseed oil, japan, varnish, and water, and is the blue pigment used mostly in distemper and water paints.

The processes of manufacturing it are quite complicated, and may be briefly described as follows: The raw materials are china clay or calcined alum, silica, sodium sulphate, sodium carbonate, sulphur charcoal, and resin.

These substances are mixed and heated in crucibles, and when cool a greenish, porous cake results. The cake is crushed and powdered, sulphur is added, and it is again roasted for a few hours. After being crushed and powdered, washed, dried, and roasted several times, a color pigment of the correct blue color is produced.—Carter Times.

### Heat An Efficient Medium in Quick Finishing

Where time is an all important factor in painting and finishing the automobile, heat may rightly be esteemed a prime essential. The baking oven, to which these columns, in succeeding numbers, will make detailed refer-

ence, is not always available in the jobbing paint shop of moderate dimensions, hence some other plan, if possible, must be devised to furnish some measure of the quick results obtained from the employment of the baking oven. This plan is simply the one which carriage painters of a former period made effective use of, and consists of introducing into the shop, or, at any rate, into the apartment, a greatly increased quantity of fresh air heated to a temperature running not less than 90 deg. uniformly sustained.

If the shop is sufficiently well made, with doors and windows tight enough to keep the hot air in, the temperature may rightly be sustained at 100 deg. In an apartment heated to this degree, all varnish coats can be greatly accelerated in drying, and an important amount of time gained in all cases of a hurry up nature. In the priming and primary surfacing coats, for rapid drying, this degree of heat may be used effectively, and these slower drying coats brought along at a rapid pace and in a hard, fine condition. We personally have used this plan to good effect in connection with the quick painting and finishing of carriages, and it is our privilege to know some very able car painters who have used it with equally good effects. It is an exceedingly good substitute for the baking oven; it costs a comparatively small amount to demonstrate, and it may be tried in any shop.

To try the plan it will, of course, be necessary to have an extra varnish room in which to work, and a room in which to run the freshly coated work and in which the high temperature may be maintained. It must be understood that this degree of heat should be kept at a uniform point. A small variation, with a little cooling temperature, will work disastrously for the varnish, and especially for the finishing varnish. While it is not quite so important that the degree of heat be kept at a uniform level when the primary surfacing coats are being given their Trukish bath, still it is not desirable to have the heat vary to any considerable extent. In the case of the finishing varnish: it were better for the lustre of the varnish if the heated room be kept dark while the varnish goes to a dust proof condition.

---

### Plaid Painting

Lately some exceptionally attractive effects have been produced by plaid painting over natural wood finished grounds. In this class of painting it is necessary that between both the horizontal and vertical stripes the wood ground should be plainly shown. The squares of natural wood should have a very distinct individuality as distinguished from the plaids of color. When the work has been nicely brought out, with accuracy in the lines, and brilliancy in the color, the effects are sure to be something quite out of the ordinary. The stripes, as a rule, show to finest advantage when drawn anywhere from  $1\frac{3}{4}$  to  $2\frac{1}{2}$  in., the 2 in. stripe being the happy medium. To illustrate. Take a panel well finished in natural wood. Now prepare, say, four different shades of verdigris, a transparent green of fine resources in the matter of color effects. Thin the pigment to the proper striping consistency with turpentine, and then with a swan quill camel's hair pencil proceed to lay in the lightest shade of the verdigris. Use the next darker shade for the second line, the next darker for the third line, and so on until the fourth and darkest shade has been laid. Then from the darkest shade ascend to the lightest, and vice versa, until

the entire panel has been filled up. In drawing the vertical or right angle lines reverse the order of the shades, starting with the darkest and running out to the lightest.

Some additional color tone may be thrown into the field by adding some of the verdigris to the rubbing coat of varnish. The number of plaids for a given width of surface may be suited to the taste of the workman, and the number needed will be governed by the width given the stripes. A measurement of the surface will enable the workman to compute very readily the number of stripes of a given width needed. When color is added to the varnish great care will need to be exercised to prevent clouding and roiling of the effects. For the beginner, it were perhaps best to omit the use of the pigment in the varnish, using the latter clear.

---

### Some Details of the Finish

It always pays well to give attention to the detailed effects of the finish applied to the car. Nothing counts for more in the estimation of a majority of car owners than these little attentions to what are sometimes deemed the minor things of the finish. The upholstery, for example, needs to always be brushed out carefully, or gone over with the vacuum cleaner, to restore and brighten up the effect. The carpet should be cleaned, and the other furnishings given some renovation, to the end that the car interior may look quite in harmony with the painting. Perhaps the top may need renovating; at least it will require sponging and drying off. If worn much, and of leather or substitute leather, or artificial leather, a dressing of some good, dependable sort will probably be due. The fabric composing the top will naturally determine the medium best adapted to it.

Then about the finished car, as it stands ready to leave the shop, will be found, it is safe to conjecture, places here and there needing a bit of this or that paint or stain to fetch out all the balance needed to give the finished effect. Some men are very deft in doing this class of work; appearing to know by intuition the exact needs of the surface. Some one with this special gift should be detailed to take charge of this work. It will result in turning out work with no necessary detail escaping attention.

---

### Effective Painting at Small Cost

This is an item, during war times at least, worth looking into. Quite a number of cars come to the shop with surfaces lightly cut up with cracks, and stricken with a minor bit of decay, which with some brief processes of treatment may be turned out at comparatively small cost. As a matter of fact, these surfaces showing slight signs of degeneration, may be lightly sandpapered, or rubbed with pulverized pumice stone and water, and then coated with one coat of color and one coat of varnish-color, the latter being freely flowed on to help the bodying up work. Then follow with a coat of rubbing varnish in which some color had best be carried. Then after rubbing again with the water and pumice stone flour clean up and flow on the finishing varnish. If the checks are too deep to be bridged over successfully in the above way, sandpaper the surface and coat with a thin vesture of lampblack. This will get into the checks and choke them up to such an extent that after a light sandpapering, the finish can be brought out as here stated.



## Novelty in Spring Suspension

English Design Features Automatic Graduation of Effective Length—Equal Efficiency Claimed Under Varying Loads

During the past 20 years we have seen a growth of improvements and modifications in chassis design which has embodied advanced ideas and greater efficiency in almost every detail. It is quite generally recognized, however, that insofar as spring suspension is concerned, there is still room for a deal of improvement, for in this direction there has not been a progress equal to that along other general lines.

It is not to be inferred, though, that there are no better suspension systems in use today than those of a decade or more ago. Quite the contrary is true. Particularly in the case of heavy touring cars do we find a number of vehicles with suspensions of an admirable design. What is said to be an inherent defect of the ordinary laminated spring seems to be present in even the best of present day systems. The impossibility of constructing a spring of a given working length which will be equally sensitive under varying loads is something that has yet to be overcome. Maximum efficiency and the ability to stand up under its given work requires that a leaf spring be designed of a strength sufficient to resist the maximum load and still allow of a margin to take care of extraordinary stresses which are always to be encountered in traveling over bad roads.

A criticism of the general run of spring suspensions, as in use at the present time, brings out the fact that the necessary spring strength and stiffness required to carry maximum loads are not, generally speaking, reduced with a reduction of the weight carried, and consequently under a light load the spring is quite too strong, which results in its practically ceasing to prevent the shocks of bad roads, etc., being transmitted to both the chassis and the passengers.

Up to the present time it seems there has been no system devised which embodies the qualities necessary to provide for equal sensitiveness under varying loads, and yet strength enough under maximum loads to withstand any stress that may reasonably be anticipated.

A suspension system has been designed by E. B. Killen, and described in an English contemporary. It is a system in which considerable of merit deserves the attention of chassis designers and builders. Mr. Killen believes that success in spring design can be achieved along lines calculated to make the spring automatically change its length according to the load carried. He states, however, that the spring must not be graduated in the ordinary way—that is to say, in the case of a quarter-elliptic spring, from the extremity to the thick root portion attached to the frame.

The type of spring designed by Mr. Killen is well illustrated in the accompanying drawings. Fig. 1 shows, diagrammatically, a spring constructed on the principle advocated. F represents the point of attachment of the spring to the rear axle and E is a rigid abutment fastened above the top plate of the spring. The relative positions of the spring and abutment under light load are as shown by the full lines. It will be noted that the abutment is clear of the top plate of the spring behind the spring clip. It can readily be seen that, with an increasing load the spring will be deflected, and will come gradually into contact

with the abutment. Under a full load the effective length of the spring will be as indicated by dotted lines, or equivalent to the distance between B and F, and under full load and maximum shocks for which the spring is constructed the effective length is represented by the distance between C and F.

It will be noted that this spring differs from others of an apparently similar design in that it is designed with ordinary graduation and of an effective length equivalent to the distance between B and F; that is to say, it is so graduated as to be of this length when carrying maximum loads, and it also has a margin of safety for extraordinary shocks. The aim has been to provide a spring with the length from B to F equal to the length of the flexible portion of an ordinary spring designed to carry the same load. In other words, if an ordinary spring, adapted for a particular work, should be 3 ft. long, the distance between B and F would be of an equal length.

At this point the spring is lengthened from B to G, and it is to be specially noted that this extension does not carry on the graduation of the spring, the portion between B and G being constant. The result is that, be-

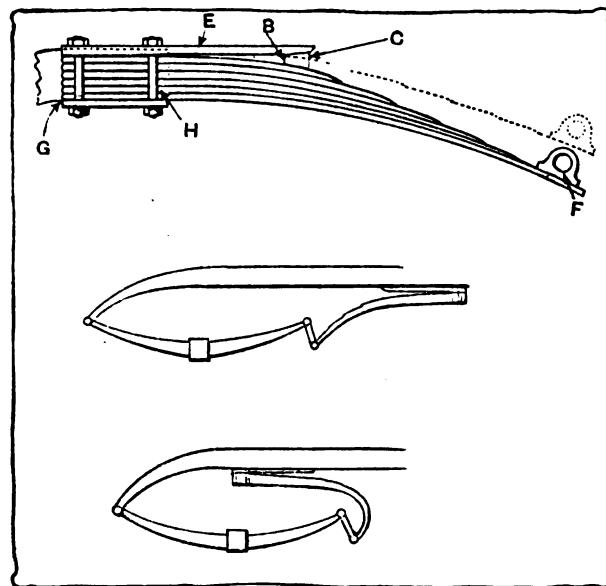

Fig. 1

tween B and H there remains an ungraduated portion of spring, which, when free to work, renders the whole spring more flexible than it is between B and F.

When under a light load the section of the spring between B and H is free of support by the abutment and consequently the reduction of stiffness serves to provide the extra flexibility required for the reduction in load. It is obvious that, as the load increases, more and more of the ungraduated section of the spring comes under the support of the abutment E and an increasing stiffness of the spring takes place. The result is plainly apparent, and there is, in effect, under a maximum load, provided a spring as originally designed to carry the maximum load.

The designer of this spring claims that, while designed to carry maximum loads with a safe margin for extraordinary stresses, it will automatically increase in effective length with a decrease of the load carried and as it increases its length, its effective stiffness decreases, thus providing an equality in sensitiveness regardless of its length or of the load carried.

Replying to the just criticism that rolling and lateral instability will result from the long and "flabby" spring under light loads, the designer asserts that all tendency to roll can be eliminated by providing adequate check devices to absorb vibrations of the spring as rapidly as possible without impairing its ability to absorb the initial shock that starts the vibrations.

The designer has found that the abutment E adequately serves the purpose of a check to the upward movement of the axle, and states that it is only necessary to attach some form of check device that will prevent too great a recoil of the spring. A piece of rope around the axle and frame was used by Mr. Killen to demonstrate the feasibility of such attachment. It appeared to serve the purpose quite satisfactorily, making an excellent snubber.

The foregoing comment is in connection with the application of the graduated spring principle to quarter-elliptic springs. A system has been perfected by the designer, adaptable to any other style of spring, including semi-elliptic, three-quarter-elliptic, cantilever, etc., and also combinations of springs, the automatic alteration in the effective length of the spring being easily attained in any case.

A springing system designed with a view primarily to allowing a very large range of axle rise or fall with but a moderate spring deflection, has also been advanced by this designer. In order to secure this result a lever is pivoted to the side frame member, one end of which can be attached to the axle of the vehicle, while the other is in connection with leaf springs constructed on a somewhat unusual principle. The large end of the lever carries a series of platforms or abutments, and the leaf spring has

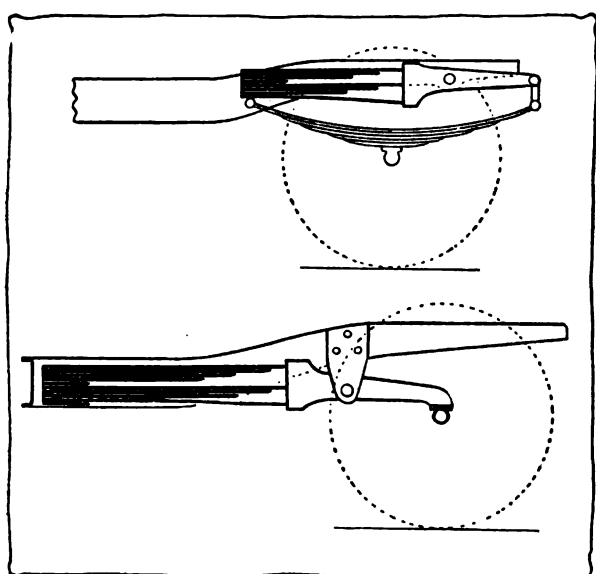

Fig. 2

several tails, one of which is in contact with each platform.

It will be appreciated that, since the lever, which may consist of an H-section beam on edge, is not pivoted centrally, a vertical movement of the longer end of the lever—the end, that is to say, connected to the axle—results in a similar movement of less extent in the shorter end that supports the tails of the leaf spring. Thus, assuming that the longer end of the lever is double the length of the shorter end, the vertical movement of the rear axle under shock is double the vertical movement of the leaf spring ends.

One of the great advantages claimed for this lever suspension is the almost entire elimination of unsprung weight so far as the springing mechanism is concerned. It will be seen, on reference to the lower illustration in Fig. 2, that the leaf spring itself, together with the bracket to which the lever is pivoted, is attached directly to the side member of the frame, and that the only mass of metal

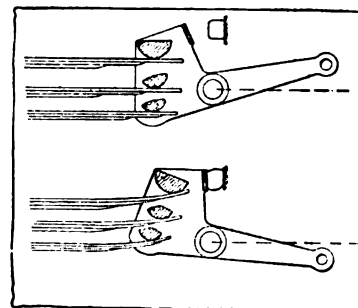

Fig. 3

that may be called unsprung is the longer part of the lever. The avoidance of unsprung weight is, of course, greatly to be desired and it is for this reason that the Killen device warrants careful consideration, as it undoubtedly points a way to improvement along this line.

Fig. 3 shows a sectional view of the large end of the lever carrying three abutments, in contact with which are three weight-supporting spring tails, and in practice there is also a fourth spring leaf which, arranged below the others, acts as a check to reduce the rebound of the spring on return. The arrangement of the spring tails and of the abutments against which they work can be such as to bring the tails into play progressively, one taking the weight under light loads, while the others come to its assistance when the stresses are increased.

Mr. Killen considers that the lever principle will be of particular advantage in connection with heavy commercial vehicles, but there is no reason why it should not be adapted to the suspension systems on private cars. It can be employed in various ways in conjunction with existing semi-elliptic springs, the lever and the tails of the additional spring then acting as a shock absorber, as suggested in the upper illustration in Fig. 2.

One of the special advantages claimed for this lever type of suspension is the relief afforded by the lever to the springs, which, when the lever end is attached direct to the rear axle, have not to transmit the drive, since this is taken by that part of the lever between the axle and the bracket holding the lever to the frame. The majority of modern cars are designed so that the rear springs are called upon not only to insulate the frame and the passengers from road shocks, but also to transmit the thrust of the back axle to the side members of the frame. In certain cases radius rods—distinct from or combined with torque members—to serve the latter purpose are provided, but these are now rather the exception than the rule.

### Electrics for Transporting Powder

The Du Pont Company, as a precaution for safety in carrying explosives, has adopted the electric truck. Special bodies have been designed with fireproof lining, covered wires and controls, and special bumpers and shock absorbers are used.

### Death of Frederick B. Hawley

Frederick Burr Hawley, president Spring Perch Co., Bridgeport, Conn., died July 19 at his home in that city of old age. He was born in Bridgeport, October 28, 1838, and succeeded his father as head of the Spring Perch Co.

### Differential Which Concentrates Power on One Wheel When the Other Loses Traction

By Marius C. Krarup

The Bailey is the name of a new differential gear for motor vehicles. It transmits power to both driving wheels when these can rotate at the same speed, but only to one wheel when the other runs faster. The power is divided at the rate at which the wheels can utilize it for traction if the wheels have the same speed but one is inclined to

of the type still used in a majority of motor vehicles the four small bevel pinions revolve on the plan of freely balancing the pressures on all teeth engaged. The engine power turns the casing which carries with it the two pivot pins on which two of the pinions are mounted. The two wheel-shaft pinions, each in mesh with both of the power-transmitting pinions, can conform with the turning of the casing by revolving, taking the wheelshafts with them. If one wheelshaft resists as much as the other, one side of the actuating pinions is resisted as much as the other, and these pinions remain balanced and unmoved in relation to their pins. The teeth engaged become mere lugs gripping the wheelshaft pinions and forcing them to follow, by revolving. But the moment one wheelshaft resists more than the other, from any cause whatsoever, the pressure on the teeth on one side of the actuating pinions becomes greater than that on the other side. These pinions are no longer balanced. They begin to revolve on their pins, toward the low-pressure side. The high-pressure side of them no longer carries its wheelshaft pinion around unyieldingly. It lags till pressures are equalized. The wheelshaft with the higher resistance turning more slowly and the other wheelshaft more rapidly in the same proportion. The total of power utilized remains unchanged, except that a portion of it is spent in overcoming the friction of the revolving pinions.

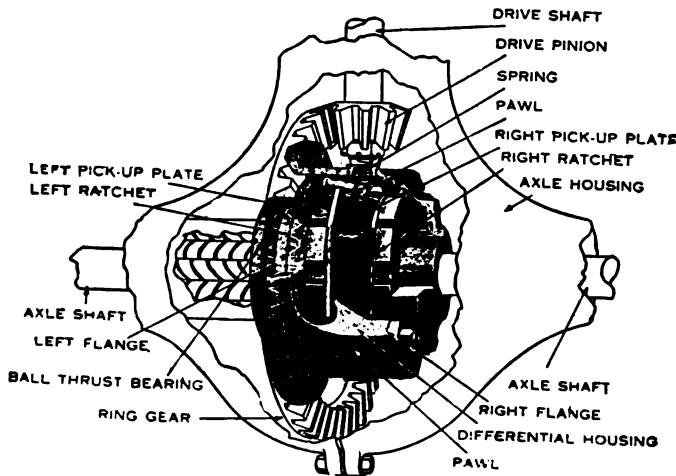

A differential which concentrates power on one wheel when the other has lost traction on a bad road

slip. Traction from one of the wheels is thus sacrificed on all curves, whether the going is good or not, in order to concentrate power and traction on one of the wheels when traction from the other is lost for lack of friction with the road surface from slippery mud or snow.

The casing is rotated by a bevel gear or worm drive, as usual. To the casing are secured two heavy pawls, of which one holds the left and the other the right wheelshaft by engaging notched discs fixed upon the ends of the shafts. The pawls are pressed against ball pivots by coil springs. Their seats in the discs are shaped so as to make the engagement hold in either direction of movement, for backward as well as forward driving; but if one of the discs is forced around by the road contact of its wheel faster than the casing and the pawl are rotated by the power, this movement is permitted by means of a cam plate that lifts the pawl out of its seat. This action seems to be as follows: The pair of cam plates is mounted on a sleeve as a rigid unit that turns around with the casing, and opposite to each pawl one of the plates has a semicircular recess that limits sideways turning of the pawl on its ball pivot, while the other plate here has a straight-line contour passing obliquely under the active end of the pawl but coming to a point directly before it. This gives the lifting action.

When both pawls drive, they stand at right angles transversely, balanced one against the other, but when one of the discs, actuated from the road, begins to push its pawl, the latter begins to turn a little on its pivot, allowing the disc the same small movement, and thereby the relatively immovable cam plate gets a higher point of support under the pawl, raising it and permitting the disc further unhindered rotation.

A comparison with other differentials illustrates the merits of each. In the ordinary balance gear differential

As friction adds tooth pressure on both sides, it may be purposely increased to modify the action of the differential. For example, if the power delivered to the casing has a numerical value of 8 and the resistance of each shaft against rotation at a certain velocity is 4, no friction in the differential arises. But when road contact interferes and one of the shafts produces increased resistance at this velocity but only 4 at a velocity 33 1/3 per cent higher, while the other shaft produces 4 at a velocity 33 1/3 per cent lower, such as may be the case when a vehicle is made to turn on a fairly sharp curve, one shaft is turned

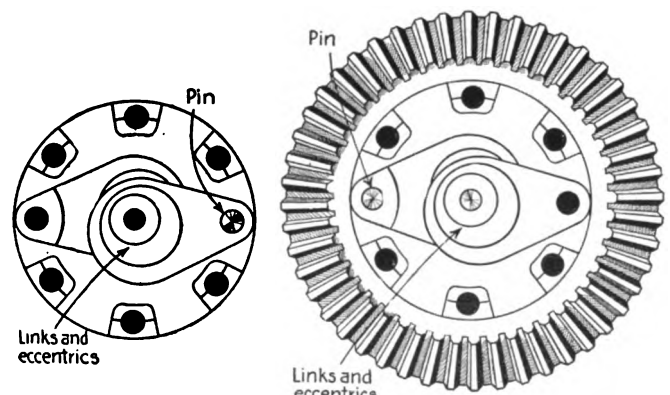

An eccentric can drive a link in and out but cannot be rotated by turning the link around

It is strong enough to resist the stresses that arise in its operation

twice as fast as the other and a certain friction is produced. In the ordinary differential this friction is negligible; but suppose it is made to have a value of 2, then there is only a power of 6 available, and there is less than 4 for each wheelshaft. The vehicle speed is reduced or more power must be turned on. Suppose, further, that one wheelshaft resists very little and does not equalize tooth pressures until it is revolved eight times as fast as the other. Then the differential works four times as much as before and the value of the friction rises rapidly.

perhaps from 2 to 8. The power is consumed. By arranging the friction on a less drastic scale, however, one can have a shaft which offers a rather small resistance under small differential action, yet equals the resistance of the other shaft as soon as its rotary velocity becomes only two or three times as high, after which no greater difference in shaft speed can be produced. The power is then divided somewhat on this plan: 2 for the slow shaft, 1 for the small friction identified with its side of the differential action, 4 for the friction of the rapid shaft and 1 for driving it. If the wheel of the rapid shaft has no traction, there is still a net power of 2 for driving.—Popular Science Monthly.

### Substitutes for Glue

A special committee of the American Chemical Society has just completed a survey of glue production and finds that with the cost of all animal products at a higher level than they have ever been in this country, glues have kept pace with the high costs of all products in this field. Animal glues have more than doubled in price in two years, and while this extreme condition is brought about entirely by the European war, due to the present condition of supply and demand, it is reasonable to expect, the report says, that in normal times animal glues will have a relatively higher cost value than ever before.

In view of the ever increasing cost of animal glue stock and the consequent higher cost of animal glues year after year, manufacturers have seen the opportunities for developing glue substitutes, the committee states. Glue substitutes are not few, but the use and application of them is not generally known and has only recently been developed commercially. Today glue substitutes are successfully used almost entirely in a wide range of industries, a brief description of which follows: In the manufacture of wall paper, for clay and ground work, for top printing and the like in paper box manufacture; on the stripping and covering machines; for all solid box work; on folding and corrugated boxes; for all hand and automatic machine work; for trunk and bag work; for drawing on canvas; leather pasting, etc.; for textiles, such as warps, and all light and heavy sizing and finishing when formerly hot animal glue was necessary; for all bookbinding work, for use on the entire book except the backing.

While the substitutes for animal glues cannot as yet be used for every purpose, they are nevertheless being successfully employed in increasing amount each year, where they are entirely supplanting the much higher-priced animal product, the report concludes.—Hide and Leather.

### To Calculate Expansion By Heat

A simple rule for calculating the expansion of iron due to raised temperature is as follows:

Multiply rise in temperature in degrees Fahr. by 7 and by the length of the iron. Mark off six decimal places on the product, and the result will be the answer in decimals of an inch.

For example, the temperature of iron at what is called a dull red is taken at 1,290 deg. F. Suppose a tire, 180 in. in circumference when measured at a temperature of 60 deg., is heated to a dull red all round, the increase will be 1,230 deg. Multiply 1,230 by 7 and by 180 and we get 1,549,800. Mark off six decimal places, counting from

the right, and we get 1,549,800, which is barely 1 9/16 in. This result is not strictly accurate. Some authorities say the multiplier should be 65 with seven decimals in the answer, and others say 68 with seven decimals. We find seven with six decimals is quite satisfactory for all practical purposes. The following is a table of colors corresponding to various degrees of temperature:

	Deg. F.
Lowest red visible in the dark.....	635
Faint red .....	960
Dull red .....	1,290
Brilliant red .....	1,470
Cherry red .....	1,650
Orange .....	2,010
Bright orange .....	2,190
White heat .....	2,370
Bright white heat.....	2,350
Dazzling white heat.....	2,730
Welding or scintillating heat.....	2,800

### Mitchell Wagon Co. Goes Out of Business

The Mitchell Wagon Co., of Racine, Wis., which was founded in 1855, has ceased to exist, as it was liquidated on July 14. All stock and much machinery has been sold to Deere & Co. for its plant at Fort Smith, Ark., and the buildings have been taken over by the Mitchell Motors Co., where automobile bodies will be constructed.

Deere & Co. have assumed the obligation of the Mitchell Wagon Co. to its customers to replace defective parts on wagons sold during the last year. Arrangements are also being made to supply wagon parts from the regular Mitchell patterns to Mitchell customers throughout the country. Correspondence with reference to Mitchell wagon repairs should be addressed to the John Deere Wagon Works, Moline, Ill.

The Mitchell Wagon Co. was founded by Henry Mitchell in 1855 and a few years later his two sons, Henry and Frank, and two sons-in-law, William T. Lewis and Calvin D. Sinclair, became associated with him in the great industry. The factory buildings covered 20 acres of land.

In 1910 the Mitchell Wagon Co. merged with the Mitchell Automobile Co. and automobiles and farm and spring wagons were manufactured. Three years ago there was a dissolution, one syndicate taking over the automobile plant and the other the wagon plant. All of the men who were interested in the original company, excepting Frank L. Mitchell, have passed away.

### C. B. N. A. Convention

The annual convention of the Carriage Builders' National Association will be held in Chicago, September 25, 26 and 27. This will be the 45th annual meeting of this association.

Beginning on September 24 and continuing through the week the annual exhibition of parts of vehicles, models, new inventions, horse equipment and materials pertaining to the carriage, wagon, automobile and accessory industries will be held. Both events will take place at the Hotel LaSalle. No finished vehicles will be exhibited. Exhibitors must be either active or associate members of the organization.

By way of entertainment there will be a banquet and smoker during the week. These also will take place at the Hotel LaSalle.

## Do Grinding Wheels Actually Grind?

By Howard W. Dunbar\*

It has been a much debated question from the early use of the grinding wheel up to the present time as to just what occurs when the grinding wheel comes in contact with a piece of steel, cast iron or other hard material, and it probably will be surprising as well as interesting to know that the opinions of almost every one on this subject are correct to a greater or lesser degree.

In the early use of the grinding wheel and grinding machine the operation was nothing more than a polishing one, in which the material removed from the work was worn away by abrasion, friction, polishing, or whatever you may desire to call it. This fact was due to various reasons. Principally, however, was the fact that the grinding machine was light, inexpensive and did not provide the proper support for the grinding wheel; and, too, the wheel in itself had not been developed to the high degree of refinement now usually found and always possible in a grinding wheel.

Even today, with good, heavy grinding machines, incorrect wheels, speed of work revolution or speed of wheel are used, which produce just as indifferent results as were always evident by the older methods. However, the reason for these indifferent results today cannot be



Photomicrograph of chips from a grinding wheel

charged to the grinding machine or grinding wheel, but rather to a lack of knowledge on the part of those responsible for such work for not selecting proper wheels or proper speeds to produce the best results.

Because of these facts, when some people say that grinding is nothing more than the rubbing away of material by abrasion they are correct; when others say that it is a polishing operation they are correct; and when still others say that it is a grinding operation which does not actually remove slivers of metal they are correct. By the ideal conditions, with the right wheel, right work speed, right type of machine, right kind of an operator, the grinding wheel actually cuts the metal and produces chips which resemble in shape and form chips produced by a lathe tool, only they are very much smaller and there are a great many more of them. These are the conditions which the grinding machine engineer always thinks of when speaking of the grinding operation. The object which should be constantly before every grinding operator is to make his wheel act in such a manner as to produce

these little chips, because under these conditions the most metal is being removed, the greatest amount of work is being produced, and the machine and wheel are being used at their highest possible efficiency.

In the illustration accompanying this article is reproduced a photomicrograph of chips removed by a grinding wheel operated under the proper conditions.

It is possible with most wheels of average grain and grade to so regulate the work speed, wheel speeds and conditions of grinding as to make the wheel actually produce these little chips. The skill of the operator and his knowledge of the art of grinding play an important part in the amount of work produced and the results accomplished. Today with a wheel 2 in. wide of the grain size commonly used, there are approximately 1,171,000 little cutting particles coming in contact with the work every minute the wheel is revolved at the recommended speeds, and accordingly there is an equal number of little steel chips removed from the work in the same time. If this width of wheel is increased, more and more particles are caused to do their share of the work, and more and more chips will be produced when the wheel is used under correct conditions. It is for this reason alone that the wide wheel is used in cylindrical work.

## Grinding as a Substitute for Milling

A radical change in the machine shop methods in the manufacture of motor trucks with a view of materially reducing the cost has recently been adopted by the Federal Motor Truck Co., Detroit, which has substituted disc and cup wheel grinding for milling wherever possible in the machining of castings. The change was decided upon when new models were developed and the design was studied from a manufacturing point of view in order to apply disc grinding to as many castings as possible. The brackets for various purposes, as well as some other parts, are now disc ground instead of milled.

The change in the method, says *Iron Age*, started with the design, and the first application is in the pattern shop where the bracket patterns are made so that the castings are relieved wherever possible and only the edges and where the bolts go through have an actual flat contact. This design reduces greatly the amount of the surface to be machined and this surface is ground on a disc grinding machine. The results obtained are claimed to be better than where a flat machined surface is provided by the milling operation.

One type of brackets used are angle brackets, such as those for the steering gear, radius rod and rear springs. It has been the general practice to mill these brackets from the solid stock and the machine work on them is claimed to have been one of the greatest problems in motor truck manufacturing, the difficulties being due to the large surfaces that have to be machined, the heavy milling machines and large diameter cutters required, expensive fixtures and high grade labor.

In making the pattern and casting no allowance is made for metal to be removed by grinding, the over size of the casting being sufficient to take care of this. Brackets are ground within 0.002 or 0.003 in., which is regarded as accurate as is necessary. Covers of transmission cases are also disc ground instead of being milled and the end flanges of transmission covers are ground instead of turned. The company is now experimenting with quick-

\*From *Grits and Grinds*. The author, Howard W. Dunbar, is with the Norton Grinding Co., Worcester, Mass.

acting cam fixtures for holding such awkward pieces as dash and cam brackets, etc., and is also experimenting in disc grinding the flat top face of transmission cases.

The grinding is done on a battery of four plain double disc grinding machines used for flat grinding, a cup wheel grinding machine for angle grinding, and a surface machine that is used for grinding small angles.

The grinding room is equipped with a very complete dust collecting system. The grinding wheels are covered, with the exception of sufficient space left for the work, and the abrasive and cuttings are drawn from the machine through 4 in. pipes which connect with a 15 in. pipe located on the floor back of the machines. This pipe is carried overhead to an adjoining room, where it connects with a dust arrester. The grinding machines are driven from one motor, which also drives the suction fan connected to the dust arrester. The arrester is equipped with special separating and baffling devices for handling the refuse. The fine particles pass directly to the hopper and into sacks beneath. The heavier material is deposited against the baffles, from which it is shaken out by a mechanical movement of the baffles after an accumulation has collected, and it drops into the hopper beneath, from which it passes into refuse sacks.

The company states that its substitution of grinding for the milling method has resulted in a very large saving in labor, doing the same work in one-sixth the time it formerly required, and a great saving in tools and material, eliminating the need of large milling machines, large diameter cutters and elaborate jigs and fixtures required in taking the heavy milling cuts.

There is also some saving of metal in the design of the castings. It is also pointed out that under the old method of milling, the casting had to be held very tightly during the milling and that it would spring back after being released, thus not retaining its shape. This is avoided in the grinding operation, as it is not necessary to hold the part as tightly as when taking a heavy milling cut.

### **Aircraft Makers Organize**

Organization of the Manufacturers' Aircraft Association will, it is believed, end the litigation over airplane patents, chiefly between the Curtiss and Wright interests. The association has opened offices at 501 Fifth avenue, New York. Membership is open to "any responsible manufacturer of aircraft, or any one who intends to become a bona fide producer, or any manufacturer to whom the United States government has given a contract for the construction of ten or more airplanes, or any person, firm or corporation owning or controlling United States patents relating to airplanes."

Fay L. Faurot, chairman of the publicity committee of the association, has made an official statement in part as follows:

"By the terms of their agreement the various patents owned by the individual members are to be taken over and so cross-licensed that their use may be made universal to all engaged in the industry. This action comes as a result of a number of conferences held in Washington by the members of the National Advisory Committee for Aeronautics and the officials of the army and navy and the Manufacturers' Aircraft Association.

"The directors of the association are: Frank H. Russell, of the Burgess Co., Marblehead, Mass.; Albert H. Flint, L. W. F. Engineering Co.; John P. Tarbox, Curtiss

Aeroplane & Motors Corp.; Harry Bowers Mingle, Standard Aero Corp.; B. S. Foss, Sturtevant Aeroplane Co.; George H. Houston, Wright-Martin Aircraft Corp., and H. E. Talbor, Jr., Dayton-Wright Aeroplane Co.

"The officers of the association are: Frank H. Russell, Burgess Co., president; Albert H. Flint, L. W. F. Engineering Co., vice-president; Harry B. Mingle, Standard Aero Corp., treasurer; Benjamin S. Foss, Sturtevant Aeroplane Co., secretary, and Benjamin L. Williams, assistant secretary.

"By the terms of the cross-licensing agreement any responsible manufacturer of aircraft, or one who intends to become a bona fide producer of same, or any manufacturer to whom the United States government has given a contract for the construction of ten or more airplanes, or any person, firm, or corporation owning or controlling United States patents relating to airplanes may become a party to the voting trust agreement, provided for in the by-laws, and can qualify as a member.

"It is the purpose of the association not to curtail, but to open up the industry in order that the government officials and airplane manufacturers may not at this time be under any improper or unfair restraint. All patent litigation relating to airplanes between members of the association ceases automatically, and the airplane industry is therefore left free to expand to any limits desired or required by the unusual demands of the war."

Secretary of the Navy Daniels has announced that the government will build an aircraft factory for the navy at a cost of about \$1,000,000 for buildings and machinery. The plant will be located at the League Island Navy Yard, Philadelphia.

### **Annual Congress of Purchasing Agents**

The National Association of Purchasing Agents will hold its annual congress at Pittsburgh, October 9, 10 and 11. The program includes business sessions for the mornings and visitation and inspection of industrial works during the afternoons.

Special features are: Tour of Pittsburgh's principal business districts by automobile during the late afternoon of the first day, and cabaret dinner in the evening to be held at one of the country clubs. The banquet will be held at the Convention Hotel the evening of the second day, October 10, with speakers of national prominence in attendance.

All purchasing agents, as well as others interested, are welcome and expected to attend and participate in the activities of the convention. Special arrangements are planned for the entertainment of the ladies.

### **Death of Roy B. Staver**

Capt. Roy B. Staver, son of the late Henry C. Staver, who for many years was head of the Staver Carriage Co., Chicago, died in New York, July 31. Capt. Staver, who was formerly commander of Battery C, Illinois Field Artillery, had just completed a course at the officers' reserve training camp at Plattsburg, N. Y., and was to have received a commission as major August 1. The decedent was a graduate of West Point, and after serving several years in the army resigned to take a position with the Staver Carriage Co., where he remained until the retirement of that concern. He is survived by Mrs. Staver, to whom he was married in 1915, and by his brother, Harry B. Staver.



## Lessons of the War in Truck Design

A lengthy address was delivered before the Society of Automotive Engineers at Washington, D. C., on June 26, by W. O. Thomas, consulting engineer, Detroit, on "Lessons of the War in Truck Design." In the main Mr. Thomas' paper was devoted to the details of the chassis, and the working parts.

It is difficult, he said, for the average engineer and writer to compare European trucks at the front with those sent over from America. They are good and bad from entirely opposite standpoints. The European trucks for the main part were better designed in detail and much more refined than the trucks sent from America, but their parts were not nearly so interchangeable, and it was more difficult to repair them on account of the hand-fitting that is an essential feature of the system under which they are manufactured. The parts of some of the American cars and trucks were interchangeable to an extent beyond the comprehension of the average British or French officer.

That portion of the paper dealing with the truck and ambulance bodies follows:

### Truck Bodies

All bodies should be wide enough to cover the rear tires in such a way that the mud will not splash on to the sides and be carried up under the cover into the body. If the treads of rear tires are standardized the bodies of both Class A and B models should be the same width. Bodies should be built as low to the ground as possible in order to assist the unloading by hand of heavy ammunition boxes.

The body parts should be strictly interchangeable. If sides are removable they should be fitted with stakes projecting both up and down in order to permit the placing of the side either way up. All of the side pieces should be absolutely interchangeable in any position, either way up.

Tail-gates particularly have been bad in detail. They should be made of hardwood, preferably white ash, not less than 1½ in. thick. The best form of hinge is made by using a 1 in. standard pipe with 3/16 x 1¼ in. strap iron bent round the pipe and extended up both sides of the gates to the top. The two straps are then bolted through, using the wood of the gate for a filler. No forgings are necessary and the strap hinges provide the necessary steel runners on the surface of the gate.

Floor boards should be uniform and each board should be provided with a steel strap runner on the center line. The boards should be protected with a thin steel U-plate, which should hold down the ends of the steel straps. The U-plates should be riveted on and the board handled as a complete unit. The cutting of trapdoors in the floor is unnecessary, because the transmission and other units have to be examined and cleaned while the truck is loaded. In reserve supply or ammunition columns especially the loads may remain in the stationary or moving trucks for weeks at a time. In normal operation the load is likely to be delivered to the first-line horse transport after dark, the truck then returns to rail-head for refilling as soon as possible and probably does not again deliver at the front until after dark the next night. Therefore all trucks should be designed to facilitate repairs and inspection while the body is loaded.

The body covers are a difficult problem. On British

trucks they are carried on front, rear angle-iron couches with longitudinal wooden purlins supporting the canvas. This system holds too much water on the top and it is common to see intermediate purlins added by the men themselves. The continuous bent-wood bow on the prairie schooner system appears to be the best. All bows should be interchangeable and the ends should be protected by metal U-plates riveted on. The rear and front flaps of the cover should be independent of the main sheet.

Bodies should be fitted with ample accommodation for the kits of four men and for tools, shovels, crowbar, axe, jack and tow rope.

All trucks at the front are crazy painted, which means that after they are painted a khaki color they are daubed irregularly with various colors to break up the surface and make them less conspicuous.

### Bodies for Ambulances

All ambulances are designed with a center aisle and a seat for the attendant on account of the number of serious cases requiring these facilities. The average ambulance is very uncomfortable for sitting cases. The best arrangement is to leave the seat in position for the lower stretchers and to hinge the back upward for the upper stretchers in the opposite manner to the ordinary upper sleeping-car berth. This arrangement provides a comfortable seat for sitting patients and also a pad under each stretcher to take the weight of stretcher patients when the ambulance strikes a bump. The side rails of the ordinary stretcher spring and the canvas sags in an uncomfortable manner without such a support.

Steel runners for the stretchers should be channel shaped on one side only and flat on the other to allow for variation in the width of the stretchers, as the stretchers stay with the patient to his journey's end.

Box or parcel bodies of practically the same type as an ambulance body are used on the same type of chassis and might just as well be interchangeable with it except for the internal fittings. These bodies are used for light service, such as mail, officers' mess cars or ammunition cars for motorcycle machine gun batteries. Their loads and speed requirements are about the same as those of an ambulance.

Special officers' bodies, some with sleeping arrangements, are also fitted to these chassis. To my mind they are better suited to the severe service than are standard touring cars. There is also the advantage of fewer types which is the real slogan the army automotive engineer must maintain.

### To Make Crucible Steel

The Century Steel Co. of America, 120 Broadway, New York, rapidly is completing its new plant at Poughkeepsie, N. Y., and expects to run the first heat August 15. The plant comprises five buildings located on a nine-acre tract at Poughkeepsie. Its output will be plain and high-speed tool steel produced in crucibles at the rate of 200 tons monthly. As soon as the present buildings are completed and in operation, the company will add an open-hearth furnace for producing special alloy steels.

The officers are as follows: President, F. B. Lown; first vice-president, H. B. Perkins; second vice-president, W. P. Hartshorne; secretary and treasurer, W. B. Dukshire; general sales manager, J. W. Phillips; works manager, W. F. Dukshire.

### Working Out a Color Scheme

Turquoise and salmon pink set off each other to perfection, but a motor car so decorated would be a white elephant in a dealer's showroom. The other extreme would be a car painted gray and brown, which, while less conspicuous, would also be less pleasing to the eye. The whole problem is to get colors which will enhance each other; to use just the shades of those colors that will blend to give perfect harmony or perfect contrast; and to tone the colors down so they will give the quietly luxurious appearance considered so essential.

Body designers in the automobile plants building the finer cars are up against this proposition continually in their efforts to create new and pleasing combinations, and it is interesting to note some of the fundamentals they must observe in working out color schemes. The chromatic chart gives fundamental rules to follow but these must be aided by sound judgment on the designer's part. It takes a man of real artistic ability and much experience to turn out the really beautiful cars.

The closer together two colors are in the chromatic scale the more they detract from each other. Colors which are complements of each other (i. e., are farthest apart in the chromatic scale) make the best looking jobs because each color sets off the other.

The use of the neutral colors introduces further limitations. While a perfect neutral neither enhances the tone of another color nor detracts from it, it itself is affected somewhat by the combination. Take a red and gray together, for instance: the red looks natural but the gray looks greenish.

It is the common practice in working out a color scheme for an enclosed car to upholster the interior in a neutral color so it will not clash with the complexions or apparel of its occupants. To secure a perfect color combination the body colors must not only go well together but must also blend properly with the interior color.

W. H. Emond, chief of the design department of the Franklin Automobile Co., Syracuse, N. Y., says that despite the limitations imposed by the chromatic laws, the possibilities for working out beautiful color schemes are endless.

The trend today is away from the ornate which formerly characterized the special enclosed jobs. A Franklin brougham, exhibited at the New York Show this year, furnished a good example of the simplicity and perfect blending of colors now considered so desirable. The interior was upholstered in neutral green Edredon and the lower body was painted sagebrush green, making a perfect match. Red being the complement of green, the correct shade, a rose lake, was chosen for the upper body. The addition of a little neutral pigment to the colors gave them the correct luster and tone.

It is Mr. Edmond's belief that the rapidly increasing number of cars in use will cause more and more motorists to turn to varied combinations of colors in order to get the desired distinctiveness.

### U. S. to Build Aircraft Factory

Secretary Daniels has authorized the construction of an aircraft factory at the League Island Navy Yard, Philadelphia, Pa.

In making the announcement Secretary Daniels said: "In view of the enormous expansion of the aeroplane

industry now being undertaken in the United States, it was felt that it was necessary to increase the navy department's facilities along these lines, not only to enable it to supply a part, at least, of its own needs, but in order that the private plants might be relieved of the experimental developments which they have hitherto undertaken and turn their whole attention to the maximum production of approved types.

"Contracts have been placed for the factory on the basis of completion of buildings and beginning of operation in less than 100 days. The total cost of the buildings and plant will be in the neighborhood of \$1,000,000, and it is expected that when the completed plant is working up to its capacity it will utilize the services of approximately 2,000 employes and be capable of producing 1,000 small planes per annum, or a corresponding output of the larger types.

"The navy department has a small flying field at the League Island yard adjacent to the factory and excellent facilities for hydroplanes, so that it will be able to utilize this plant to keep the navy in the forefront with the latest developments in aircraft."

### Removable and Divisible Wheel

From England comes the information that a patent has been issued to one W. Paddon, of Essex, covering the invention of a detachable and divisible wheel. The accompanying illustration shows quite well the type of construction of this

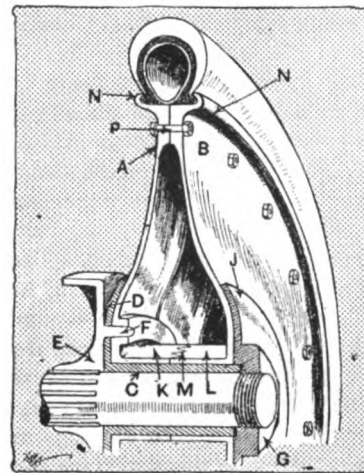

wheel. It is built up in the form of two discs, each carrying at its outer edge, formed solid with the disc itself, a half-rim. Both discs are mounted on a flanged sleeve, and are provided with teeth cut on their inner faces, which interlock with each other and aid in forming a perfect connection between the discs at their outer circumference.

Simplicity in changing tires is claimed as a merit for this type of wheel. It is only necessary to remove a few small bolts, take off the outer disc, and slip the new tire over the half-rim remaining. The valve of the air tube passes through a semi-circular channel in each half-rim and disc, access to the valve being obtained through a small door, conveniently placed in the outer disc.

### Lelands Buy Plant

Henry M. and W. C. Leland, president and vice-president of the Cadillac Motor Car Co., respectively, have purchased the old Warren-Detroit factory in Detroit, and will use it for developing and manufacturing airplane engines. The factory was used by the Rands Mfg. Co. for some time after the Warren-Detroit car went out of existence, and later by the old Lozier Motor Co., and is highly suitable for the purpose.

### Government Will Finance Manufacturers

The War Department is preparing to finance manufacturers of airplanes who are not in position to supply funds for the purchase of materials, equipment, etc., for the execution of large contracts. The aviation bill, passed by the House and signed by the President a few days ago, makes no provision for advances to manufacturers, and Section 3648 Revised Statutes specifically forbids such payments except under certain prescribed conditions which do not apply to this emergency. Many manufacturers of aircraft have valuable patents and have been building airplanes on a small scale, but lack the necessary capital to enlarge their operations and take an active part in the building program, which is counted upon to produce more than 20,000 fliers within the coming year.

To meet this emergency Representative Hulbert of New York has introduced a bill to remove the restrictions on advance payments imposed by Section 3648 Revised Statutes as they apply to the expenditure of appropriations contained in the aviation act. Quick action on this measure is looked for, and as soon as the bill is passed the War Department will be in position to place a large number of contracts which manufacturers with moderate facilities now hesitate to undertake.

### Airplane Natural Product of Vehicle Builder

The airplane propeller is clearly a job for the automobile or carriage factory's wood shop, where, with some changes in equipment and tools, the present mechanics can "produce the goods," says Aviation. Already manufacturers of wood-working machinery whose names are well known today to body builders are announcing new adaptations of their machines for airplane propeller work.

Automobile factories have become accustomed to all kinds of sheet metal stampings, both steel and aluminum, in the manufacture of the different styles of bodies. The industry has developed the stamping of motor car seats, fenders, tanks, etc., and can easily turn its attention and bring its experience to the needs of constructors of flying machines. Already we hear of at least one large body shop which is in readiness to furnish stampings in aluminum for airplanes, such as bonnets, engine under-shields, pilot screens, passenger and pilot seats, exhaust box stampings, engine back plates, etc. Metal working machinery made by firms now supplying the motor trades can be adapted to airplane requirements very readily.

### Women Employes in the United States

Figures as to the increasing employment of women in the United States are given as follows in a late census bulletin: There were 3,596,615 women over 16 years of age engaged in industrial occupations out of a total of 18,957,672 in 1890, the proportion being 19 per cent. In 1900 the number of those employed rose to 4,833,630 out of a total of 23,485,550, or 20.6 per cent. In 1910, on the other hand, the number of women over 16 years of age employed rose to 7,438,686, out of a total of 29,188,575, or 25.5 per cent. The proportion of the single women employed to the total number of such women grew from 43.1 per cent in 1890 to 45.9 per cent in 1900 and to 54 per cent in 1910. The percentage of the widowed and divorced advanced from 29.9 in 1890 to 32.5 in 1900, and to 34.1 in 1910. The proportion of the married women employed to the whole number of married women in-

creased from 4.6 per cent in 1890 to 5.6 per cent in 1900, and 10.7 per cent in 1910.

### Union Carriage and Gear Co. Insolvent

An order to show cause why the company should not be voluntarily dissolved on the ground that it is hopelessly insolvent and providing for the appointment of D. L. Cornwall as temporary receiver was entered by Justice Edgar C. Emerson, returnable August 9, upon the petition of the majority of the directors of the Union Carriage & Gear Co., Watertown, N. Y.

The company assets aggregate \$37,000, while its liabilities amount to \$55,000. The company is capitalized at \$50,000, all of which has been issued and is outstanding, and there is a mortgage on the plant of \$32,500 held by the Watertown Savings Bank. The inventory of the plant shows it to be worth \$35,000, while the company's accounts receivable amount to \$800 and its cash to \$674.27. The plant has been closed for over a year.

### Death of S. R. Bailey

Samuel R. Bailey, who a few years ago was one of the most widely known manufacturers of carriages in this country, passed away July 10 at his home in Amesbury, Mass. He was 79 years old. Mr. Bailey began his business career in East Pittston, Me., in 1856. Ten years later he moved to Bath and established a plant for building sleighs and carriages. In 1872 Mr. Bailey went to Boston, and in 1878 became a member of Wood, Bailey and Wood, of Boston. Here he introduced the Bailey sleigh to the trade. When the partnership was dissolved Mr. Bailey, in 1882, went to Amesbury to manufacture carriages, and when motor cars became popular put the Bailey electric automobile on the market. He retired from business a few years ago. A son and a daughter survive him.

### Lectured on Truck Springs and Axles

J. R. Phillips, service manager of the Sheldon Spring and Axle Co., Wilkes-Barre, Pa., and Walter Jones, sales manager of the same company, spoke on truck springs and axles at a meeting held under the auspices of the United States Motor Truck Co. at the latter concern's plant in Cincinnati, O., Friday, July 6. About 150 persons attended the lecture, representing practically every truck concern in Cincinnati. Following the lecture those present were the guests of the United States Motor Truck Co. at a luncheon.

### Defiance Machine Works Expansion

Defiance (O.) Machine Works has increased its capital stock from \$600,000 to \$1,200,000, and has acquired adjoining property on which it will erect additional two-story brick and concrete buildings, in addition to enlarging its machine shop. Special metal-working machinery will be added to its present line of wood-working machinery. Some changes in the organization have recently been made: R. P. Kettenring is vice-president, and George A. Ensign and W. F. McCarty, works manager and chief engineer, respectively.

The Electric Vehicle Section, National Electric Light Association, has authoritative statistics showing that the number of electric vehicles in operation in England has increased 536 per cent in the last three years.

# Vehicle Industry News in Brief

## Truck Builders

Indiana Truck Co., Marion, Ind., has reduced its capital stock from \$250,000 to \$1,000.

Steamotor Truck Co., Chicago, has increased its capital from \$100,000 to \$10,000,000 for expansion.

Tower Motor Truck Co., Grennville, Mich., has increased its capital stock from \$50,000 to \$100,000.

Ford Motor Co., Detroit, has begun shipments of trucks to its various branches. The chassis price has been fixed at \$600.

Forschler Motor Truck Mfg. Co., New Orleans, La., will erect a building 147 x 220 ft. for the manufacture of motor trucks.

Continental Motors Corp., Detroit, will manufacture trucks as well as passenger car engines, and will provide increased activity.

Reo Motor Car Co. plans to turn out 100 per cent more trucks and 5,000 more passenger cars. The Reo company has sufficient materials to meet needs to January, 1918.

General Motors Truck Co., Pontiac, Mich., is working on a government order for 1,000 ½-ton truck chassis for ambulances, to be used by the medical corps of the army.

Duplex Truck Co. is rushing work on the construction of its new plant at Lansing, Mich. It is expected the plant will be in operation December 30. H. M. Lee is president.

Triangle Truck Co., St. Johns, Mich., will have its new plant in operation about November 1. The concern, which was recently organized, will make 1½-ton vehicles.

Conestoga Motor Truck Co., Lancaster, Pa., has acquired about 15 acres of property with 1,200 ft. frontage on the Pennsylvania Railroad, for the construction of a new plant.

Nash Motors Co., Kenosha, Wis., has contracts for the purchase of passenger cars totalling \$32,000,000 and trucks aggregating \$10,000,000 in value, all for delivery during the coming year.

Burlington (Wis.) Truck Co. has been organized by members of the Burlington Blanket Co. and will establish a plant in the Ebbers Building to manufacture truck units for Ford chassis.

Sanford Motor Truck Co., Syracuse, N. Y., has completed plans for additions to be made to its plant on West Fayette street. It manufactures motor trucks of one to five tons capacity.

Gary (Ind.) Motor Truck Co. is installing machinery and soon will begin operations in its new plant with about 50 men. The company started in a temporary plant at Hobart over a year ago.

Peerless Truck and Motor Corp., Cleveland, O., for the six months of the present year has broken all previous shipping records for the company, having shipped an average of 80 trucks a week since January 1.

Republic Motor Truck Co., Inc., Alma, Mich., plans immediate construction of an addition to plant No. 2, which will double the capacity and add 100,000 ft. of floor space to the motor division. Charles Rhodes is secretary.

Forschler Dual Frame Truck Co., Los Angeles, has been incorporated with a capital of \$100,000, to manufacture trucks of special type. J. F. Manning, H. W. Wyatt and L. W. Van Dyke, all of Los Angeles, are the incorporators.

Stableford Truck Sales Co., Plainfield, N. J., has been incorporated with a capital of \$125,000, to manufacture motor trucks and other vehicles. Frank T. and Marcus L. Clawson, Plainfield, and Neil W. Benedict, Newark, are the incorporators.

White Co., Cleveland, will build an addition, 125 x 500 ft., of brick, steel and reinforced concrete, one and two stories with basement, to be used for a finishing department for motor trucks. Some additional equipment will probably be required.

Higrade Motors Co., Harbor Springs, Mich., manufacturer of ¾-ton trucks, has secured a tract of land in Grand Rapids, Mich., and construction work will be rushed on a factory to be ready for occupancy early in September. J. Elmer Pratt is president.

Transcontinental Motor Truck Corp., Buffalo, has been incorporated with a capital of \$1,250,000, to manufacture automobiles and motor trucks, engines and kindred specialties. The incorporators are E. S. Stengel, R. A. Schmidt and P. J. Bloxham, all of Buffalo.

Triangle Truck Co., St. Johns, Mich., has started work on its new plant and it is expected to be in operation November 1. The building is one story, brick, fire-proof construction, 70 x 236 ft. The company will manufacture 1 and 1½ ton trucks, and will start with 40 men on its pay-roll.

Guaranty Motors Co., recently organized at Cambridge, Mass., with Samuel W. Prussian as president, will make a truck attachment for use with Ford and other cars and also plans to make a complete motor truck in the near future. A Torbensen internal drive axle will be used on the unit.

White Motor Co., Cleveland, has closed an order for trucks with the French government, the first installment of which, it is understood, will call for 1,500 trucks, the full order taking 18 months to complete. Addition to the plant will be completed by early fall and will add 50 per cent to the production of trucks, increasing the output from 8,500 to 12,500 trucks per annum.

Buick Motor Co., Flint, Mich., will produce a new light truck car for the 1918 season. It will be known as model E and will have a Buick 3¾ x 4¾ in. valve-in-head engine. A loading space of 42½ x 70 in. is to be provided and it will have a carrying capacity of 1,500 lbs. The wheelbase is to be 106 in. With an open express type body, canopy top and side curtains, it will sell for \$790.

Racine (Wis.) Motor Truck Co., organized about four months ago to build commercial vehicles, and now occu-

pying temporary quarters at 1109 Sixth street, is contemplating the erection of a complete new plant during the coming year. It will then also engage in the manufacture of internal spur gear drive axles on a commercial basis. Charles H. Piggins is vice-president and chief engineer.

Four-Wheel-Drive Auto Co., Clintonville, Wis., is rushing work on the construction and equipment of a large machine-shop addition, undertaken a short time ago, to enable it to make the earliest possible delivery of 3,250 Class B army trucks to the government, at the rate of 175 trucks per month, beginning August 1. The trucks will be equipped with ordnance towing hooks and the contract price is \$3,248 each.

Taylor Motor Truck Co. has been organized by R. E. Taylor, formerly of the R. E. Taylor Corp., Garford and Gramm-Bernstein distributor in New York City. The Buford Motor Truck Co., Fremont, O., has been purchased by the new company, of which R. E. Taylor is president; E. F. Twyman, vice-president and sales manager; R. J. Willoughby, engineer, and Putnam Drew, advertising manager.

International Motor Truck Co., Allentown, Pa., has completed the order received from Great Britain for 150 Mack "Bulldog" trucks. Each will have a capacity of five tons and is meant for service at the French front. All the trucks went to New York on their own wheels for shipment across the ocean. During June the plant turned out 140 trucks, but in the future will not try to exceed the usual rate of 125 a day. The Allentown trucks are said to have proven very valuable in the moving of heavy artillery.

### Body Builders

Hercules Buggy Co., Evansville, Ind., has contracted with the government to manufacture 4,500 motor truck bodies.

Dayton (O.) Body Co.'s new plant is rapidly nearing completion and installation of machinery will be begun at an early date.

Pioneer Trailer Corp., Detroit, has been incorporated with \$30,000 by W. M. Cornelius, Daniel E. Leiderbrandt and Arthur S. Squires.

Bay City (Mich.) Auto Body Co., formerly the Kelly Body Co., has moved from the west side to the east side and is rapidly expanding its business.

Studebaker Corp., South Bend, Ind., is erecting a new building at Kendall and Garst streets, to cost \$150,000, to be used as a forge room and heating plant.

Hoskins Body Co., Chicago, has been incorporated at Springfield, Ill., with a capital stock of \$10,000, by J. C. and Byron Hoskins and P. J. Grogan, of Chicago.

Hardy Buggy Co. plant at Paducah, Ky., was destroyed by fire with a loss of \$50,000 to equipment and contents, exclusive of the buildings. W. T. Hardy is president.

Mitchell Motors Co., Racine, has purchased the plant of the Mitchell Wagon Co., Racine, and will devote it to the manufacture of automobile bodies and coach work.

Olds Motor Works, Lansing, Mich., has let contracts for the erection of factory, 80 x 400 ft., making the second building now under construction. It expects to triple its production.

Sayers & Scoville Co., Cincinnati, has acquired a manufacturing building at Gest street and the C. H. & D. R. R., and will establish an automobile plant at an early date. Particulars are not yet available.

Wilson Body Co., Bay City, Mich., has completed its new plant and is ready for the installation of machinery. The main plant has a floor space of 90,000 sq. ft. and with smaller buildings totals 114,500 sq. ft.

Mueck Auto Body Co., St. Louis, has been incorporated with capital stock of \$30,000 by Frank J. Mueck, Henry J. Happel and William Happel to manufacture vehicle bodies and is in the market for equipment.

Maibohm Wagon Co., Racine, Wis., which engaged in the manufacture of passenger automobiles about a year ago, has reorganized as the Maibohm Motors Co., with a capital stock of \$500,000, under a Maine charter.

Foley Motor Car Co., Newark, N. J., has been incorporated with a capital of \$25,000, to manufacture motor cars and parts. E. J. and F. P. Foley, Montclair; and Peter A. Bannigan, Paterson, are the incorporators.

Doble Detroit Steam Motors Co., Detroit, has been incorporated in Delaware with capital of \$10,000,000 to manufacture automobiles, trucks, airplanes, etc. Abner Doble, T. P. Myers and Claud L. Lewis are the incorporators.

American Auto Body Co., Milwaukee, has been incorporated with a capital stock of \$40,000 to manufacture passenger and commercial automobile bodies. The incorporators are David J. Borun, L. L. Gridley and Henry J. Bradley.

Samson Trailer Co., Grand Rapids, Mich., has purchased ten acres of land as a factory site and will immediately begin the erection of the first unit of its plant, 80 x 160 ft., one story. The property adjoins the plant of the United Truck Co.

C. R. Wilson Body Co. plans an addition to the Detroit plant for the purpose of increasing the facilities of the metal working department; the addition to cost \$175,000. The Bay City plant, now building, will be in operation early in August.

Wolverine Motors Co., Inc., Kalamazoo, Mich., has been organized to manufacture motor cars. The company is an outgrowth of the Wolverine Detroit Motors Corp., and is headed by A. H. Collins, formerly with the R. C. H. and Locomobile companies. The capitalization is \$125,000.

Lang Body Co., Cleveland, has purchased five acres of land near West 106th street and Loraine avenue. The first of a series of buildings will be erected, and used for the construction of automobile and airplane bodies. It will cost \$100,000. Charles E. J. Lang, of the Baker R. & L. Co., Cleveland, is president.

Appleton (Wis.) Auto Body Co. has increased its capital stock from \$10,000 to \$25,000 preparatory to erecting a complete new passenger car body plant. The present works, established in February, have been outgrown. Work will begin at once on a two-story fireproof factory, employing between 60 and 75 operatives, to be ready October 1. J. L. Tollefson and R. A. Schwartzburg have taken an interest in the company. Gustave Seeger is vice-president and general manager.

Fisher Body Corp., Detroit, has been negotiating with the government for the manufacture of airplane bodies,

which, exclusive of the engines, are estimated to cost 50 per cent of the total expense of airplane construction. The Fisher Body Corp., which has an annual capacity of 370,000 motor car bodies annually, was reported some time ago to have completed plans for entering the airplane field. The facilities of the company are well adapted to the construction of airplane bodies.

Lindsay Bros., Minneapolis, have added a line of commercial stake and dray bodies to fit extension trucks of Ford chassis. They have heretofore sold commercial bodies for Fords that are designed to be put directly on the Ford chassis after the regular body is removed. The new line is built for use in connection with extension trucks to make a vehicle of greater capacity. Lindsay Bros. have had an excellent trade on the regular commercial bodies and anticipate a good demand for the new line.

Springfield Body Corp., Detroit, has approved plans for increasing capital stock, and has placed B. F. Everitt in the presidency. Geo. W. Woods is secretary and treasurer, and the directorate includes these two with H. Bill, C. A. Macdonald, E. W. Wagner of E. W. Wagner & Co., New York and Chicago brokers; Harral S. Tenney, and E. W. McGookin. The capital stock is to be increased to \$3,250,000. In addition to body work, the company is also figuring on the manufacture of airplane parts of both wood and metal.

### Car Builders

Staver Motor Car Co., Chicago, will build a three-story 110 x 157 ft. reinforced concrete factory.

Maxwell Motor Co. will erect a new factory, two stories, 100 x 300, at Windsor, Ont., to cost \$150,000.

McLaughlin Carriage Co., Oshawa, Ont., announces a new 1918 model that will appear about September 1.

Olds Motor Works, Lansing, Mich., has broken ground for a two-story 80 x 400 ft. addition containing 60,000 sq. ft.

Saxon Motor Car Corp., Detroit, has taken a lease on the plant formerly occupied by the Abbott Motor Corp. The plant has 60,000 sq. ft. of floor space.

Stanley Motor Carriage Co., Newton, Mass., will confine its production to a single chassis with a wheelbase of 130 in. The special over-size chassis and power plant for commercial service and buses will no longer be made.

Warren-Nash Motor Corp., New York, has been incorporated with an active capital of \$78,750, to manufacture motor vehicles of different kinds. A. F. Skinner, C. B. Warren, and J. J. Jansen, Jr., 37 Wall street, are the incorporators.

Shadburne Bros. Co., which recently absorbed the Bour-Davis Motor Car Co. of Detroit, will place on the market a new car, the Shadwick Six, in August, at its new plant in Frankfort, Ind., and will continue to manufacture the Bour-Davis cars.

Moore Motor Vehicle Co., Danville, Ill., has been incorporated with a capital stock of \$100,000. It is established in a plant at Danville, and is assembling 100 machines, parts for which were made in Minneapolis. George L. Moore is president.

Autocar Co., Ardmore, Pa., has plans prepared for enlarging its plant. A five-story machine shop will be built adjoining the present factory and a sales and service

building will soon be erected in Brooklyn, N. Y. J. H. Goulding, Ardmore, is the purchasing agent.

Packard Motor Car Co., Detroit, is employing at present about 500 negro laborers in its plant. The white men are advanced to better positions due to the increased volume of work. It is estimated that Detroit's negro population has been increased 10,000 in the last year.

Grant Motor Car Co., Cleveland, will begin the erection of a one-story concrete addition, 60 x 260 ft., to be used as a machine shop, painting and enameling department. The company has under consideration the erection of five additional buildings, which may be started later this year.

Chandler Motor Car Co., Detroit, has started operations on a new four-story reinforced concrete building, 220 x 60 ft., as the first unit of a series of buildings to be erected within the coming year, increasing its capacity 200 per cent. The company now has a capacity of 150 complete sets of engines and axles per day.

Pullman Motor Car Co.'s plant at York, Pa., and other assets, were offered at receiver's sale July 23 and sold to New York and Philadelphia capitalists for \$408,597. L. Goldstein & Sons, Philadelphia, bought the service department for \$115,000; Michael Dwyer, of New York, the completed cars for \$53,597; Joseph Frankel, New York, the plant, machinery and their assets for \$240,000. The plant will continue in operation.

### Parts Makers

Hayes Wheel Works Co., Anderson, Ind., is enlarging its plant.

Victor Wire Wheel Co., Kalamazoo, Mich., has been incorporated for \$500,000.

Fafnir Bearing Co., New Britain, Conn., has awarded a contract for an addition, 50 x 80 ft., one story.

Philadelphia (Pa.) Storage Battery Co. has completed its new factory and will be able to double its production schedule.

Defiance (O.) Machine Co. is having plans prepared for an additional factory to provide about 50,000 sq. ft. of floor space.

Toledo (O.) Machine & Tool Co. is taking bids for the erection of its new one-story machine shop and foundry, about 158 x 375 ft.

Hayes Motor Truck Wheel Co., St. Johns, Mich., is using women help for the first time. Fourteen women are employed at present.

Advance Auto Sheet Metal Works has opened a factory in Jackson, Mich., for the manufacture of automobile sheet metal work.

Lee Tire & Rubber Co.'s general offices, at present located in the plant in Conshohocken, Pa., are to be moved to New York City.

Campbell Transmission Co., Buchanan, Mich., has been organized, and is erecting a plant to cost \$25,000. L. L. Campbell is president.

Mott Wheel Works, Jackson, Mich., an enterprise recently obtained by that city, is installing machinery, stock and other equipment in its new plant.

Underhood Motor Heater Corp., Detroit, has been incorporated by Stephen Kaladzie, Samuel V. Kowrack and James B. Gierm. Capital stock, \$65,000.



Clark Equipment Co., Buchanon, Mich., has started a factory addition, 36 x 120 ft., brick and steel construction. This company makes steel truck wheels.

Parsons Mfg. Co., Detroit, manufacturer of automobile hardware, has moved into its new factory at Stanley and Vermont avenue, where its capacity will be greatly increased.

Champion Spark Plug Co., Toledo, O., has acquired plots of land adjoining its plant at each side and across the street, to prepare for an indefinite expansion of future business.

Parish & Bingham Co., Cleveland, maker of automobile frames and other sheet metal parts, is planning the erection of a machine shop addition, 150 x 200 ft., with a saw-tooth roof.

Stanley Vehicle Spring Co., Syracuse, has been incorporated with a capital of \$100,000, to manufacture springs. W. H. Robinson, F. W. Green and H. P. Denison are the incorporators.

Dayton (O.) Wire Wheel Co., which has been manufacturing wire wheels for Fords since January 1, is planning to manufacture additional models in the near future for all makes of cars.

Detroit Pressed Steel Co., Detroit, is spending about \$200,000 in additions to present buildings to provide for a new tool room, stock room, receiving room and the initial unit for buildings for the manufacture of single disc steel wheels. C. H. L. Flintermann is vice-president and secretary.

### Ford Motor Output for Year

During the fiscal year ended July 31 the Ford Motor Co., Detroit, manufactured 735,000 cars, an increase of 200,000 cars as compared with the production in the previous fiscal year. The company is 80,000 cars behind in its orders. The record month of the year was May when 83,706 cars were sent out. The biggest single day's outrun was on July 25, 3,545 cars.

A one-ton motor truck to retail for \$600 will be made by the company in 1918. There will be no change in the price of cars.

## WANTS

Help and situation wanted advertisements, 1 cent a word; all other advertisements in this department, 5 cents a word; initials and figures count as words. Minimum price, 30 cents for each advertisement.

**Wanted**—Copies of The Hub of May and July, 1916. Must be in good condition. Address Trade News Publishing Co., corner Elm and Duane streets, N. Y. City.

### PATENTS

**Patents**—H. W. T. Jenner, patent attorney and mechanical expert, 606 F St., Washington, D. C. Established 1883. I make a free examination and report if a patent can be had and exactly what it will cost. Send for circular.

### FOR SALE

**For Sale**—"Motor Body Work for Commercial Cars," a new text book dealing with the construction of all types of bodies for business purposes. Contains also six working drawings and a glossary of technical terms, together with diagrams and sketches. Price, \$1.20 net; by post, \$1.56. Orders should be accompanied by remittance. Cooper's Vehicle Journal, Ltd., 19 Garrick street, Long Acre, London, England.

## Index To Advertisers

American Motors Corporation.....	4
Barrell Co., Wm. L.....	42
Bliss, E. W., Co.....	3
Bookwalter Wheel Co.....	44
Bradley, C. C., & Son.....	45
Brennan Motor Mfg. Co.....	47
Bridgeport Coach Lace Co.....	39
Century Steel Co. of America, The.....	43
Columbus Bolt Works.....	Back cover
Cowles, C., & Co.....	44
Crane & MacMahon, Inc.....	Back cover
Decker, J. C.....	44
Dixon, Joseph, Crucible Co.....	9
Dowler, Chas. L.....	44
DuPont Fabrikoid Co.....	42
Eccles, Richard, Co.....	46
Empire Art Metal Co., Inc., The.....	8
G & O Mfg. Co.....	47
Gray, Peter, & Sons, Inc.....	45
Hartford Auto Parts Co.....	3
Hoopes Bro. & Darlington.....	47
Hotel Brunswick.....	45
Hotel Tuller.....	38
Johnston, R. F., Paint Co.....	44
Keratol Co., The.....	42
Laidlaw Co., The.....	2
Lumen Bearing Co.....	41
Millersburg Fifth Wheel Co.....	44
Mulholland Co., The.....	44
Murcott-Duden Co., The.....	2
Norton Grinding Co.....	5
Parrott Varnish Co., The.....	2
Pettingell Machine Co.....	7
Pierce, F. O., Co.....	40
Pittsfield Spark Coil Co.....	40
Porter, H. K.....	45
Poughkeepsie Utilities Corp.....	38
Pressed Steel Co.....	2
Quickwork Co., The.....	45
Rome-Turney Radiator Co.....	46
Russell, Burdsall & Ward Bolt & Nut Co.....	45
Sheldon Axle & Spring Co.....	10
Sherwin-Williams Co., The.....	41
Standard Oil Cloth Co., Inc.....	6
West Tire Setter Co.....	47
White-Quehl Mfg. Co.....	44
Wilcox Mfg. Co., D.....	47
Willey Co., C. A.....	46
Williams, J. H., & Co.....	Front cover
Wing, Chas., Co.....	44
Yoder Company, The.....	Back cover

**DO YOU HEAR**  
 the **UTILITY KID** signaling  
 you to go ahead and get  
**UTILITY**  
**VARNISH**  
**RENOVATOR**



**The Particular Auto Owner**

<b>USES,</b>	<b>UTILITY</b>
<b>VALUES,</b>	<b>VARNISH</b>
<b>REQUESTS,</b>	<b>RENOVATOR</b>

The best sales proposition of the year for jobbers and dealers

List Prices:

4 ounce bottles, 25c	Quart cans, \$1.00
12 ounce bottles, 50c	Gallon cans, 3.00
Sprayer, 25c	

**POUGHKEEPSE UTILITIES CORP.**  
44 WINNIKEE AVE., POUGHKEEPSIE, N. Y.



Meet me at the Tuller for Value, Service, Home Comforts

**NEW**  
**HOTEL TULLER**  
Detroit, Michigan

Center of business on Grand Circus Park. Take Woodward car, get off at Adams Avenue.

**ABSOLUTELY FIREPROOF**

200 Rooms, Private Bath, \$1.50 Single, \$3.00 Up Double
200 " " " 2.00 " 4.00 " "
100 " " " 2.50 " 4.50 " "
100 " " " 3.50 to 5.00 " 5.00 " "

Total, 600 Outside Rooms

**ALL ABSOLUTELY QUIET**

Two Floors—Agents' Sample Rooms

New Unique Cafes and Cabaret Exellente

**Vehicle Mechanics**

Desiring to improve their present Condition should attend the

**TECHNICAL SCHOOL**

For

**Automobile Draftsmen and Mechanics**

Supported by the

The National Automobile Chamber of Commerce, Inc.

The object of the School is to teach men to design vehicles and make working drawings, and to otherwise facilitate their work in the shop. Only those men employed in carriage or automobile building or their accessory trades are admitted to its privileges.

The classes are conducted in three divisions, viz.: Corresponding, Day, and Evening. The former is open during the entire year, while the day and evening classes are in session only from October 1 to April 1.

The tuition is moderate.

For prospectus and full particulars, write to the instructor,

**ANDREW F. JOHNSON,**  
20 West Forty-fourth St.,  
**NEW YORK CITY**

Please mention "The Hub" when you write.

# FABRICS BRIDGEPORT

*The Keynote of Harmony*



There is a quaint charm, a feeling of restfulness, an air of smartness and the true personality of the owner pervading every interior fashioned with Bridgeport Fabrics.

Each Bridgeport Interior, from the luxurious carpetings to the filmiest of silk curtains, is a true expression of Decorative Art at its best. Each is free from mechanical detail, portraying an artist's conception of the blending of rare colorings, in a variety of textures to meet the requirements and taste of all motorists.

The keynote of a Bridgeport Interior is harmony, and is worked out from the raw material to the finished product on our own looms. An effect is produced which bespeaks of the individuality of your own home. Every interior is conceived for the motorists who want an inimitable and final touch to their car, that is only possible through 80 years of decorative service.

**BRIDGEPORT COACH LACE CO.**

Bridgeport, Conn.

New York Showrooms, 1731 Broadway



The Planing Tool has a serrated ring of improved steel which affords unequal variety and rapidity of adjustment. The ring is correctly hardened to resist the wear of the cutter. The body of the holder receives a very different heat treatment that prevents breakage.



# The Way We All Use Machine Tools

*May Win or Lose the War!*

Why not profit by the late experience and example of other nations and adopt tool holder economies now.

Cut out machine idleness due to shaping, sharpening and needless shifting of forged tools. Keep many machines working full time with the same tool steel and less labor than solid tools require to keep one machine busy on part time.

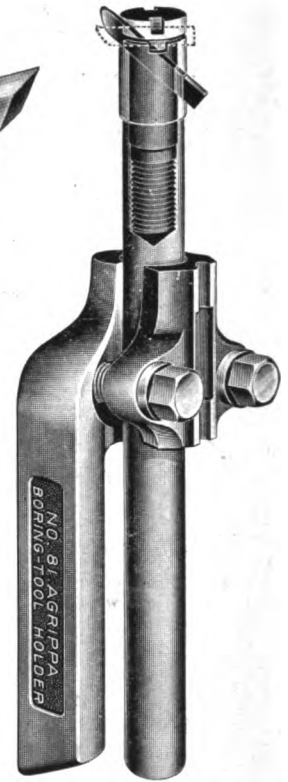

The Boring Tool takes any size or shape of bar and requires no bushings. Its sleeve bar cap admits a straight or angular cutter; either can be quickly inserted at the business end of the bar without removing the cap or disturbing the setting of either the bar or the holder.



The Threading Tool with lockable spring head will do roughing, finishing and threading at one setting of the tool post.

## Williams' "AGRIPPA" Tool Holders

**"THE HOLDERS THAT HOLD"**

save the most time and need the least shifting.

*We will ship them promptly if your dealer can't supply you from stock*



A tool that performs both cutting off and side work by the mere substitution of suitable cutters tells its own story of economy.

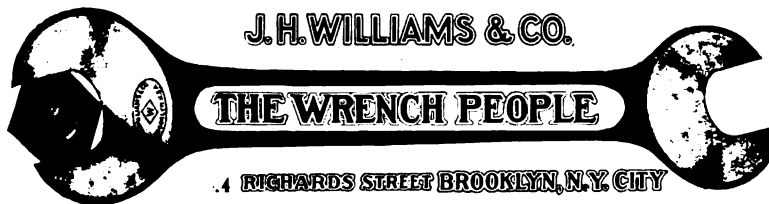

Please mention "The Hub" when you write

# The Hub

Vol. LIX

NEW YORK, SEPTEMBER, 1917

No. 6

Published Monthly by

## THE TRADE NEWS PUBLISHING CO. OF N. Y.

PAUL MORSE RICHARDS, *President* G. A. TANNER, *Secretary and Treasurer*  
EDISON BUILDING, COR. ELM AND DUANE STS., NEW YORK

THE HUB, a monthly authoritative journal on all subjects pertaining to the vehicle industry from its engineering and construction viewpoints. It publishes information of live interest to manufacturers of motor vehicles, trailers, carriages, wagons, the accessory trades, repair shops and garages.

Subscription price for the United States, Mexico, Cuba, Porto Rico, Guam, the Philippines, and the Hawaiian Islands, \$2.00; Canada, \$2.50; payable strictly in advance. Single copies, 25 cents. Remittances at risk of subscriber, unless by registered letter, or by draft, check, express or post-office order, payable to the order of THE TRADE NEWS PUBLISHING CO.

For advertising rates apply to the publishers. Advertisements must be acceptable to publishers. Copy for new advertisements must be received by the 25th of the preceding month. All communications must be accompanied by the full name and address of writer.

Entered in the New York Post Office as Second-class Matter

## War's Influence on Industries

There are many signs indicating that production in all the industries is going to be more scientifically conducted in the future than it has been in the past. Industries are not going to grow up quite so much at random or be managed quite so much by rule-of-thumb as heretofore. They will be more carefully located, methods will be more generally standardized, relations with employes will receive greater consideration, and from the beginning of the process to the end every detail will be studied to obtain greater efficiency. Many of our manufacturers have been making good progress along these lines, but the investigations of the Federal Trade Commission show that, taking the whole body, there is vast room for improvement, even in the matter of calculating costs. A majority of them, according to the commission, lack an adequate system of cost-keeping.

The war has had a great influence upon the industries of Great Britain and the other countries of Europe. They have been forced to make the best possible use of their man-power, and patriotism has prompted both employers and employes to be more conciliatory toward each other and more receptive toward the introduction of new machinery and new methods. The increase in production which has resulted has been a revelation and will have lasting results upon industry. The larger output per man reduces the cost of the product, and makes it possible either to lower the price of the product to the consumer or pay higher wages, or to divide the savings between the public, the employers and the employes. The United States must not be behind other countries in these economies. The war is causing an increase in our industrial capacity, and it will be a problem to keep this capacity

employed when the war demands fall off and the first urgent peace demands are satisfied. We must be able to hold our own in competition with other countries, and, furthermore, we must understand that the home demand for everything can be increased by reducing the cost. If everything we consume were halved in price we could buy twice as much, provided the reduction was accomplished by a corresponding reduction in production costs.

## Government Price Fixing

Price fixing at the hands of the government authorities and the new measures for taxation are still factors of uncertainty in business calculations. The authorities will closely supervise the movement of the wheat crop out of first hands, through the process of manufacture into flour, and through distribution to consumption, determining the profit of every handler.

The price of coal has now been fixed by an order of the President, varying with different fields. The price of steel is under inquiry and may be authoritatively fixed for government use. There is every reason to believe that the authorities will be guided in this policy by what they conceive to be the best interests of the public, and that they will seek to make prices that are fair to producers, but the whole policy is an experiment, and unless it is carried to extremes and the results are very pronounced it will never be known whether the experiment is successful or not. It is not by any means certain that prices made artificially low are the most desirable. Prices have an important function in bringing supply and demand into equilibrium, adjusting them to each other.

## Excellent Freight Showing

With an increase in equipment of only 3 per cent, the railroads of this country rendered nearly 26 per cent more freight service in June this year than in the same month last year.

The report on freight traffic for June was compiled by the Bureau of Railway Economics on returns from 29 railroads having a combined mileage of 125,488 miles, or approximately half the total railroad mileage of the United States.

In June, 1916, these roads gave freight service equivalent to carrying 15,650,194,737 tons of freight one mile, while for the same month this year they carried 19,676,463,348 tons one mile, an increase of 25.7 per cent.

Intensive car loading plus an increase of 13.6 per cent in the number of miles a day which the railroads have been able to make their freight cars travel is largely responsible for the excellent freight showing for June. The distribution of empty cars, irrespective of ownership, into

districts where they have been most needed, has also helped.

Intensive loading has increased the number of cars available to meet the demands of the government and the shipping public by many thousands. Prompt loading and unloading of cars and the efforts which the railroad employes are making to keep cars out of the repair shops have also done much to facilitate the movement of freight.

### C. B. N. A. Convention

The forty-fifth annual convention of the Carriage Builders' National Association will be held in the Hotel LaSalle, Chicago, September 25, 26 and 27, 1917. The annual exhibition of vehicle parts and materials will take place in the same hotel September 24 to 28. Ample space for the exhibition and a commodious hall for the convention are both provided in the hotel, and the association from past experiences has learned that this arrangement is very satisfactory to its members.

The entertainment features of the convention will be as elaborate as in the past, the annual banquet being scheduled for Thursday evening, September 27. The members of the C. B. N. A. will find a hearty welcome in Chicago and they will also discover that no more pleasant city can be found for a September vacation trip than the second city of the United States.

While it may be expected that a considerable number of firms will contract for space before the exhibition date, the number of exhibitors already booked assure an extensive and interesting showing of parts and accessories. To date of going to press the following names of exhibitors at the convention have been received:

Auto Vehicle Parts Co., Cincinnati, O.  
 Backstay Machine & Leather Co., Union City, Ind.  
 Blacksmith & Wheelwright, New York.  
 C. Bradley & Son, Syracuse, N. Y.  
 F. S. Carr Co., Boston, Mass.  
 Geo. R. Carter Co., Connersville, Ind.  
 L. C. Chase & Co., Boston, Mass.  
 Cleveland Hardware Co., Cleveland, O.  
 Conneaut Leather Co., Conneaut, O.  
 Cortland Carriage Goods Co., Cortland, N. Y.  
 Crandal-Stone & Co., Binghamton, N. Y.  
 DuPont Fabrikoid Co., Wilmington, Del.  
 Eberhard Mfg. Co., Cleveland, O.  
 Enterprise Plating & Brass Co., Cincinnati, O.  
 Federal Rubber Co., Cudahy, Wis.  
 Fernald Mfg. Co., North East, Pa.  
 Firestone Tire & Rubber Co., Akron, O.  
 Goodyear Tire & Rubber Co., Akron, O.  
 Illinois Iron & Bolt Co., Carpentersville, Ill.  
 Kelly-Springfield Tire Co., New York.  
 Keystone Forging Co., Northumberland, Pa.  
 Monarch Carriage Goods Co., Cincinnati, O.  
 Mossman-Yarnelle Co., Fort Wayne, Ind.  
 Muncie Wheel Co., Muncie, Ind.  
 Owensboro Forging Co., Owensboro, Ky.  
 Pantasote Company, New York.  
 Pioneer Pole and Shaft Co., Piqua, O.  
 Raser Tanning Co., Ashtabula, O.  
 P. Reilly & Son, Newark, N. J.  
 Royer Wheel Co., Aurora, Ind.  
 Sheldon Axle and Spring Co., Wilkes-Barre, Pa.  
 Spokesman, Cincinnati, O.

Standard Varnish Works, Chicago and New York.  
 Union Bow Co., Cleveland, O.  
 Ware Bros Co., Philadelphia, Pa.  
 Western Spring & Axle Co., Cincinnati, O.  
 D. Wilcox Mfg. Co., Mechanicsville, Pa.  
 C. A. Willey Co., Long Island City, N. Y.

### Annual Congress of Purchasing Agents

From the standpoint of practical analysis of business conditions and consequent suggestions for the shaping of a course to meet extraordinary conditions yet to come, the annual congress of the National Association of Purchasing Agents, to be held in Pittsburgh, October 9, 10 and 11, is taking on an importance which is impressing itself nationally.

It is recognized that the purchasing agent, particularly during business periods such as now prevail, must be expert not only in the unerring probing of business conditions, but must build upon the sequence of his experience, opinions which must correctly anticipate the future. Failure to anticipate the trend of business affairs, as swayed or regulated by the progress of the war, will be a blunder impossible to remedy. With this fact generally recognized there can be no doubt that out of the meetings to be held in Pittsburgh, both formal and informal, will come much of the most important industrial and commercial news of the year.

The details of the convention are being worked out by Robert F. Blair, of the Pittsburgh Gage & Supply Co., who is chairman of the convention committee. E. L. McGrew, of the Standard Underground Cable Co., is the National association's president.

The registration of delegates will take place on October 9 at the William Penn Hotel, which will be the headquarters for the convention, and where also the convention meetings, both public and closed, will be held, and where the annual banquet, with men of national prominence for speakers, will be held.

Sight-seeing tours throughout the Pittsburgh industrial district are being arranged, although it is recognized that many of the purchasing agents will prefer to arrange their own tours and business calls to suit the particular lines in which they are engaged and concerning which they prefer to gain information at first hand. Not only the purchasing agents and the concerns they represent give to the coming convention a great amount of importance, but the government also will observe the proceedings, with the aim of obtaining reliable information to be used in connection with the purchasing commission to be operated at Washington.

### Utilization of Waste

High prices and economies enforced by war conditions have brought about some surprising changes in manufacturing practice, especially as regards the utilization of waste. A shoe manufacturer had for years disposed of small scraps of leather at a low price, as they were considered worthless for any purpose except for making charred leather used in case-hardening. The high cost of leather led him to consider other possible markets for the leather scraps, and, as a result, he is today converting the scraps into straps for slippers and realizes approximately \$3,500 yearly from material that brought less than one-tenth as much before. The Ford Motor Co. utilizes



the waste textiles, pantasote and other materials used in making tops to make spark coil boxes. The material is ground fine and then is fed to a machine having a screw or worm somewhat like a sausage machine, which is capable of forcing the material under heavy pressure into separable dies. The output of the department in which this scrap material is converted into spark coil boxes is more than 3,000 boxes a day.—Machinery.

### U. S. Army Motorized Field Battery

The United States army has developed what is believed to be the first completely motorized field battery of medium caliber guns in the world. The work has been in charge of Major Lucian B. Moody, who has been assisted by the tractor standards committee of the Society of Automobile Engineers.

European armies have reduced greatly the number of horses in artillery use, but it has not been possible to eliminate them in hauling certain of the smaller and medium types of ordnance because of the lack of a proper tractor combination of speed and power. The big creeping type tractors capable of handling the heaviest guns have been unable to make the occasional bursts of speed necessary for getting the light field guns into position and using the minimum of space that conditions on the firing line frequently make vital.

The new creeping, or self-track-laying, type of small or medium size tractor developed by the American army is built without the steering arrangement in front, and while possessing relatively as much power as the type now used in Europe, is capable of turning within its own length by simply reversing or stopping one of the creeper drivers while the other side continues to move ahead. The development in this type of tractors powerful enough to haul the heaviest guns will make them available for making the sharp turns and corners and fitting into the inconvenient spaces for which horses so far had to be used at the front. The experiments have proceeded far enough to justify plans for the successive motorization of all American artillery units except the smallest calibers required to move at very high speed over bad ground.

From a scientific and military standpoint, the tractor is much more efficient than the horse. It lasts longer, is capable of performing more work in a day, and costs less for repairs and fuel than the expense of upkeep of the horse. A tractor can, if necessary, be used 24 hours a day, while the horse has to stop for rest, sleep and feeding, and can seldom be worked more than 10 or 12 hours a day at the most.

In varnish polishing a good polish is necessary, and one with which the writer has long been acquainted consists of the following ingredients: Sweet oil,  $\frac{1}{2}$  pint; vinegar,  $\frac{1}{2}$  pint; denatured alcohol,  $\frac{1}{2}$  pint; turpentine,  $\frac{1}{2}$  pint; gum arabic, 4 tablespoonfuls. Dissolve the arabic in the vinegar, then add other ingredients.

### One Wheel "Iron-Horse"

The "Iron-Horse," built by the One Wheel Truck Co., St. Louis, Mo., is a unique tractor, designed for use with varying types of animal-drawn vehicles, having from 2,000 to 10,000 lbs. capacity. The maker claims, and the accompanying illustration will show, that the machine is used exactly as are animals, being coupled to the front of the conveyance. The unit is driven by a single wheel, the assembly consisting of a frame that carries a short body and driver's cab, and in the frame are mounted the power plant, driving and steering gears, and the conventional means of control.

The power plant consists of a special Continental engine, a four-cylinder type, the horsepower being 22.5. The engine is cooled by a forced circulation of water from a 56 gallon steel tank, no radiator being used. The water tank is used also to balance the power plant and to afford weight for traction.



The iron horse, a one-wheel tractor adapted for hauling any ordinary animal vehicle with load of from one to five tons

The frame is carried on vanadium steel, semi-elliptic springs, 44 in. long and  $2\frac{1}{2}$  in. wide, and these are mounted on a heat treated nickel steel axle. The drive wheel is wood, artillery type, 34 in. diameter, with 14 spokes, and with a 34 x 10 in. solid tire of pressed-on type. There are two brakes, the service brake being an external contracting type on a drum 10 in. diameter and 3 in. face on the cross shaft, and the emergency set has an internal expanding shoe that operates within a drum 18 in. diameter and 3 in. face on the wheel. The unit is controlled by a 20 in. steering wheel and the usual hand levers and foot pedals. The cab and seat are upholstered in leatherette and the cab has an adjustable windshield and roller curtains.

H. B. Krenning, formerly president of the Dorris Motor Car Co., St. Louis, is president of the company; Louis Goodhart, who has engaged in selling motor vehicles since 1092, is secretary; B. R. Parrott is chief engineer; Walter G. Vollmer is assistant engineer, and Charles A. Merien, formerly service manager for the Dorris Motor Car Co., is factory manager and assistant to the treasurer.

Ford Motor Co., Detroit, will build a four-story addition to plant A.

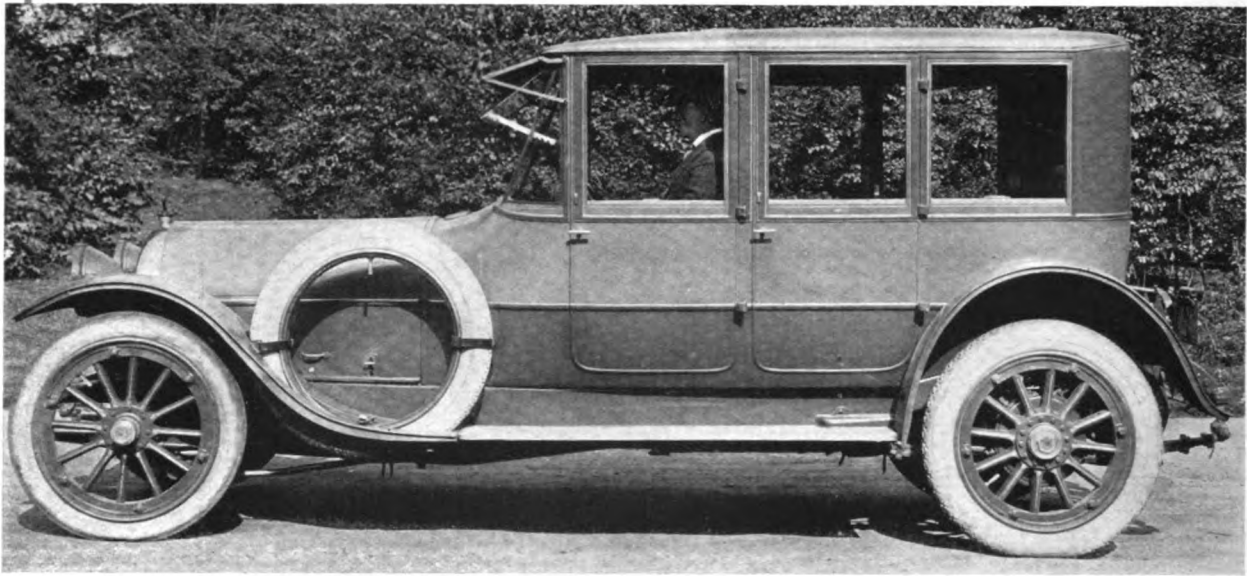

**FIVE-PASSENGER SMALL ENCLOSED DRIVE**  
 Body by Brewster, New York. Mounted on Simplex chassis

There are two extra seats in the rear compartment, one which rides backwards and the other sideways; consequently seven people can ride in the car very comfortably. The car is particularly adapted for the owner who wishes to drive personally and has been found to be an extremely popular body.

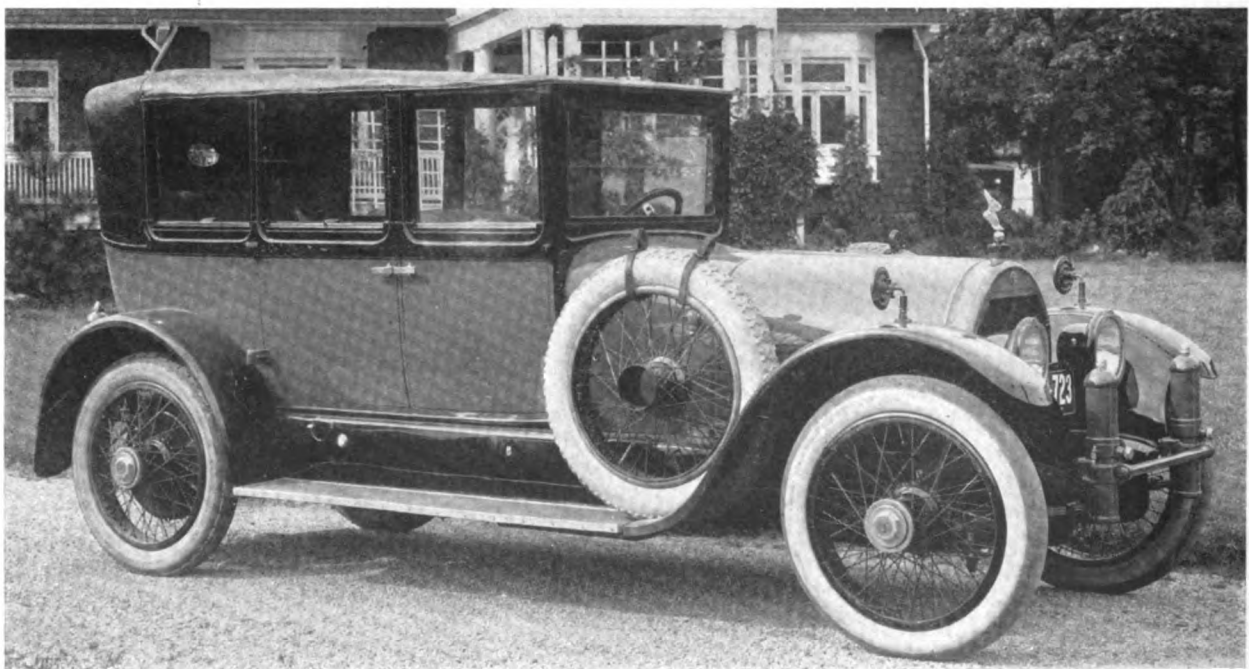

**CONVERTIBLE SEDAN**  
 Body by The Holbrook Co., New York. Mounted on Cadillac chassis

The beauty of this body is that it can be operated from the inside by one person with one hand and the entire length of time required to transform the closed body into a touring body is exactly 1½ minutes and vice versa. Another excellent point is that no pillars or glass windows have to be removed; the former holding down and the latter disappearing into the body and out of the way. The construction is most simple and a child could operate the top.

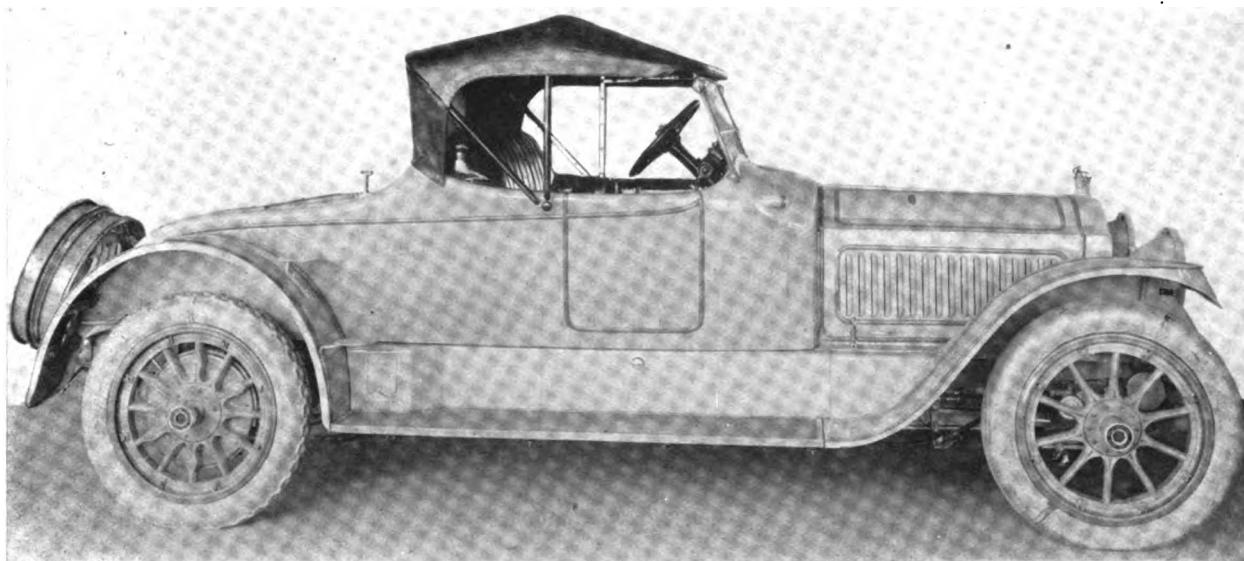
**RUNABOUT**

Body by Chauncey Thomas & Co., Inc., Boston. Mounted on Packard chassis

Has a rear folding seat to accommodate two persons and has two side steps so as to make seat more easily accessible; rear curtain rolls up at top so that conversation can be held with occupants of front seat; it has a special windshield made by Chauncey Thomas & Co., Inc., and on inside of top there is a dome light in the corner; there is a ventilating door in cowl dash and body is built of aluminum.

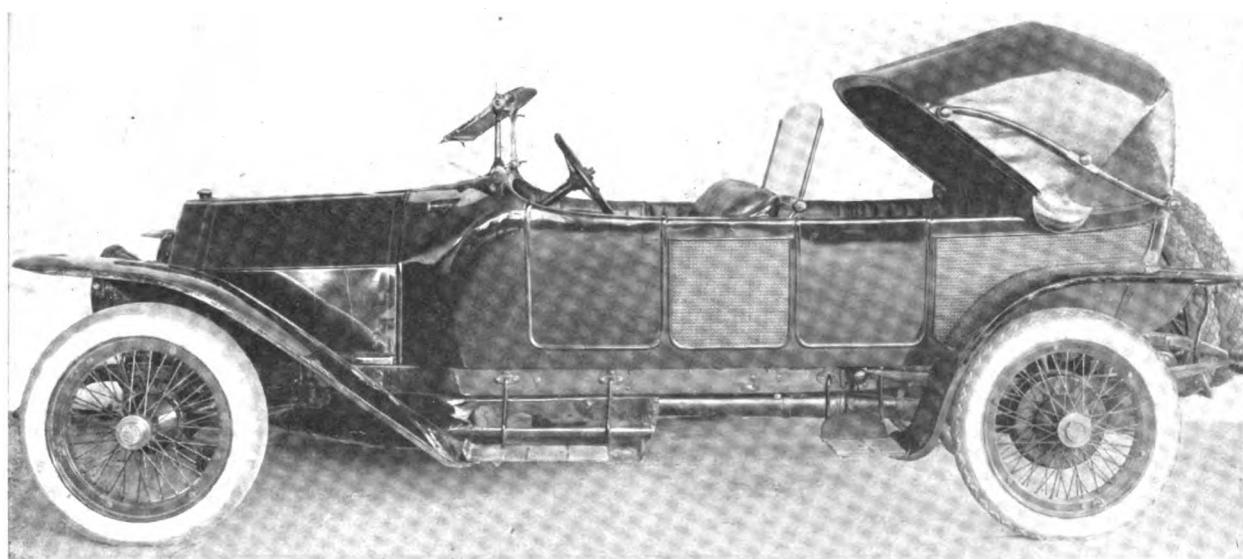
**TOURABOUT**

Body by Chauncey Thomas & Co., Inc., Boston. Mounted on Lancler chassis

Painted English purple lake; the top is built over the back, and is painted a cherry red at the belt; running gear is also painted cherry red; cane work on side is painted maroon, same color as the body. The windshield, it will be noticed, has curved top lines; the back one folds and, when in this position, can be utilized as a robe rail. This car is kept at the Massachusetts Club in Boston and is considered one of the finest turnouts on the Boston boulevards.

### Spring Welding and Tempering

Spring welding is a common feature in summer work, and when the vehicle appears the smith must either supply a new leaf for the broken one, or else effect a weld. Many men cannot agree on this matter of spring welding. You may have no steel suitable in stock, for instance, but the writer has seen a spring welded satisfactorily by upsetting in the break of each piece of broken spring, and to each piece of spring leaf that has been upset weld a small piece of soft iron. This done, weld both ends of the spring together and the leaf is O. K. and ready to be hardened. If welded in this way, the ends may be too long and require cutting and trimming down, but care must be taken not to weld in too much iron—merely a thin sheet at each broken end, weld smooth and no thicker than the spring.

If you have steel on hand to make a new spring, cut off sufficient and draw down the ends to the correct shape. Take a leaf just above or below the leaf that is broken and you have to replace, and heat the new leaf to a red heat all over. If using the fire, be careful to get a very even heat; a furnace is a very handy outfit for such a job. When you have a heat, put the leaf just where it goes above or below the leaf you are going to shape it to, and if you have a set of spring rolls, roll both leaves. If you have no rolls, take a pair of tongs and squeeze the leaves together, linking the ends of the tongs. Some men believe in hitting the leaf with a hammer to shape it to its mate, but every time you hit the hot leaf, it dents so that the concave side is marked and in bad condition.

So long as we are on the spring question, the automobile spring deserves some consideration. Some men repair automobile springs and make new ones, but do not temper them. Other men maintain that the temper should be drawn, claiming that the spring is no good unless very carefully drawn in oil. Opinions on this point differ greatly, but generally speaking a spring with the temper properly drawn is the only proper spring to make. In the way of tempering, different methods are used. One man proceeds as follows:

When the leaf is welded and shaped he clamps a bolt in the vise long enough to take two leaves, using a ring nut in the bolt. Then the main leaf of the spring is placed on the bolt and the next leaf heated to a cherry red. This is placed on the first leaf and the nut tightened up. The leaves are gripped with tongs at the tips and dipped in soft water until cold. After all the leaves are so treated, the temper is drawn, then the leaves are heated to a black and laid aside to cool. Springs tempered this way have undergone severe road tests.

Cooling in oil from a good red heat is another method, or the leaves may be hardened in oil and drawn to a single flash. Yet another: Heat the whole leaf to an even heat for its entire length, then cool in oil and flash off once. If the fit of the leaf is not perfect,peen the leaf slightly while hot. If the best steel is used and it is properly tempered the springs will stand up well. For automobile work, vanadium steel will be found preferable.

### Vehicle Taxation in Siam

The Siamese Government Gazette, of June 23, 1917, announces that motor cars of all classes, except those owned by the King, must be registered and licensed. Drivers must also pass a satisfactory examination in handling cars and must be over 16 years of age and of good moral rec-

ord. Paid drivers on applying for licenses must produce letters of recommendation from their employers, who will be held responsible for their good behavior.

The license fee per year is \$1.85 for motor-car drivers, \$0.74 for motorcyclists, \$4.44 for private cars, \$18.50 for cars for hire, \$22.20 for passenger cars, \$44.40 for lorries of three to five tons, \$29.60 for lorries of less than one ton, and \$1.85 for motorcycles, with \$1.85 extra for side car attached.

Special permits for dealers and manufacturers of motor cars will be issued at \$11.10 per year. Bicycles also must be registered and pay a yearly license fee of \$1.11. Motor cars and cycles, and bicycles, however, are not manufactured in Siam.

Horse carriages, handcarts, oxcarts, and jinrickshas, with their drivers, must also be registered and licensed at fees ranging from \$1.85 to \$5.55 for each vehicle, and \$0.37 for drivers per year.

### Motor Cars in the Federated Malay States

The last five years have witnessed a steady increase in the imports of motor cars, both in the Straits Settlements and in the Federated Malay States. There is a growing popularity for the American car in these markets, as compared with those from other countries. It is stated that the same conditions obtain in Singapore and other parts of the Straits Settlements.

The numbers of motor cars registered in the Federated States from the various countries of manufacture during the last five years, not including busses, trucks and vans, were as follows:

	1912	1913	1914	1915	1916
United Kingdom .....	340	437	512	532	587
Canada .....	12	186	187	221	462
Belgium .....	21	41	59	59	56
France .....	242	250	229	195	221
Italy .....	8	16	8	11	21
Switzerland .....	...	3	4	4	...
Germany .....	35	47	45	44	51
United States .....	143	256	294	370	719
Unknown .....	1	...	...	...	2

The reason for the popularity of the foreign-built (Non-British) cars, says the chief secretary of the Federated Malay States, in his annual report, is that they are cheaper to buy and cheaper to run and more suitable (in the opinion of those who buy them) for that country.

### Veteran Electric Vehicles in Siam

J. L. Hansen, of the Siam Electricity Co., of Bangkok, Siam, on a visit to this country, says that his company has a fleet of five electric vehicles, two of which have been in use since 1904. These 13-year-old veterans are used for lamp delivery, while the larger trucks are used by wiremen, and for various other uses of the company. They are operated by unskilled natives.

### Schwab Heads Adams-Williams Co.

At a special meeting of the board of directors of the Adams-Williams Mfg. Corp., New York City, Francis C. Schwab was elected president. C. D. Williams was re-elected as vice-president and L. W. Schwab was chosen as secretary and treasurer. The company is manufacturing and marketing a line of convertible tops or glass enclosures for several well known makes of pleasure automobiles.

# How Factory Lay-Outs Aid Production

## Problem of Transporting Materials and Products Through Plant Reduce Production Costs

By Edward K. Hammond \*

**I**N order to obtain the maximum efficiency in manufacturing it is essential for all the men and machines in a plant to be kept constantly supplied with work. No matter how cleverly methods of machining may have been worked out, nor how suitable the mechanical equipment

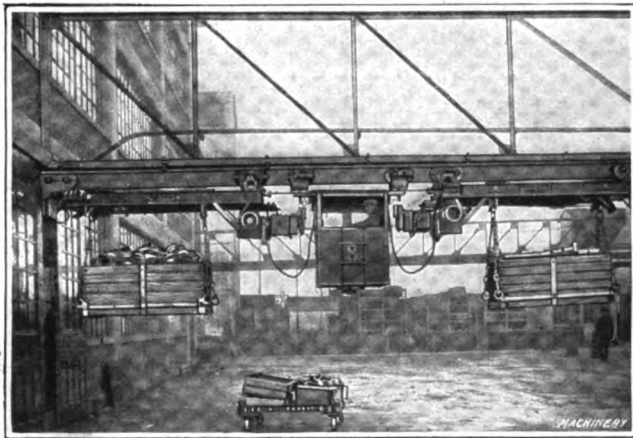

Fig. 1—Where it is desired to transport small pieces on trolleys it is necessary to equip trolleys with a carrier in order that a load approximating the trolley's capacity may be carried at each trip. This view in the Ford Motor Co.'s plant shows trolleys with carriers for handling small castings, built by the Sprague Electric Works, New York City.

may be, a satisfactory rate of production cannot be hoped for unless there is a uniform supply of raw material or pieces in course of production to keep all the machines and operators constantly at work. In studying conditions in a variety of manufacturing plants engaged in the production of many different kinds of work, it frequently becomes apparent that there is loss of production and profits due to the management's failure to appreciate the importance of this point. In such plants production may be high for periods of considerable duration, but due to lack of foresight in anticipating some unusual delay, a whole department may be held up for some time because of failure to bring a supply of work from one of the preceding departments.

### Co-operation Between Management and Workers

To successfully solve the problem of transporting material and product through an industrial plant requires a detailed study of manufacturing conditions in that plant made by experienced industrial engineers who are capable of recommending those forms of equipment best adapted to meet the requirements found. But there is one condition which the industrial engineer cannot control, namely, the intelligent use by workmen of the equipment provided.

\* Associate editor of Machinery.

This article and illustrations reproduced through the courtesy of Machinery.

Co-operation between the employes and management of an industrial plant is of primary importance in order to handle material with the maximum rapidity, and various methods of securing such co-operation have been adopted, the most successful of which is some form of bonus system. Where carefully planned methods of handling material and conducting machining operations have been worked out in sufficient detail to include giving definite instructions concerning the method of handling each piece, and where the incentive to follow these instructions is created through payment of a bonus to efficient workers, some marvelous productions have been made, and in this connection it is noteworthy that these results have been secured through the development of common-sense time-saving methods of working, and not through the expenditure of extraordinary effort on the part of the men. For the manufacturer who realizes the necessity of improving his operating conditions, the bonus system is worthy of most careful consideration, as the incentive offered a man to work for higher wages will be more effective than trying to make him work by any direct form of supervision.

### How Factory Lay-out Affects Transportation Problems

Every year industrial engineering becomes a more complex profession, because constantly increasing competition between manufacturers leads them to rely upon the indus-

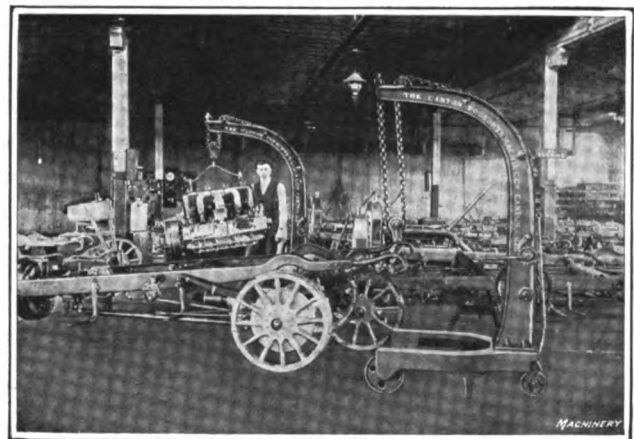

Fig. 2—Portable cranes are used for many purposes. Their chief field is for lifting work in confined spaces that cannot be served by traveling cranes or trolleys. They can also be used to advantage where there is not enough work to warrant installing a crane or trolley system. Canton Foundry & Machine Co.'s portable cranes are shown in use in a garage.

trial engineer to suggest methods of reducing production costs which would either have been considered too complicated to justify their adoption under conditions that existed a decade ago, or which were seemingly of so trivial



a nature that it took time to make apparent the savings that might be effected through their use. One of the most obvious methods of facilitating the work of handling materials and products, and one which has been made the subject of frequent comments in the technical press, is to arrange all the departments in a factory and all the machines in each department so that the work follows a continuous route through the plant without the expenditure of unnecessary time and labor in carrying it back and forth. A great deal of profitable work has been done in rearranging the lay-out of departments in factories and of the equipment in departments in order to provide a continuous route over which materials are carried without the necessity of long hauls between departments, and

aisles, the aisles are marked on each side by a white paint line; but men in a shop are only human, and if some advantage may be secured by having a box or bar of steel extend slightly over the aisle line, or if it is easier to pass another truck by running the wheels of a truck a little way into the part of the shop reserved for strictly manufacturing operations, it is not probable that the white paint line will have any great restraining influence. While these may seem trivial infractions of rules, they are likely to cause serious delays if allowed to go unheeded. Realizing this fact, the Timken-Detroit Axle Co., Detroit, Mich., adopted an expedient which has proved of material value. Down each side of all aisles in the factory 2 x 4 in. scantlings are nailed to the floor, and they are protected

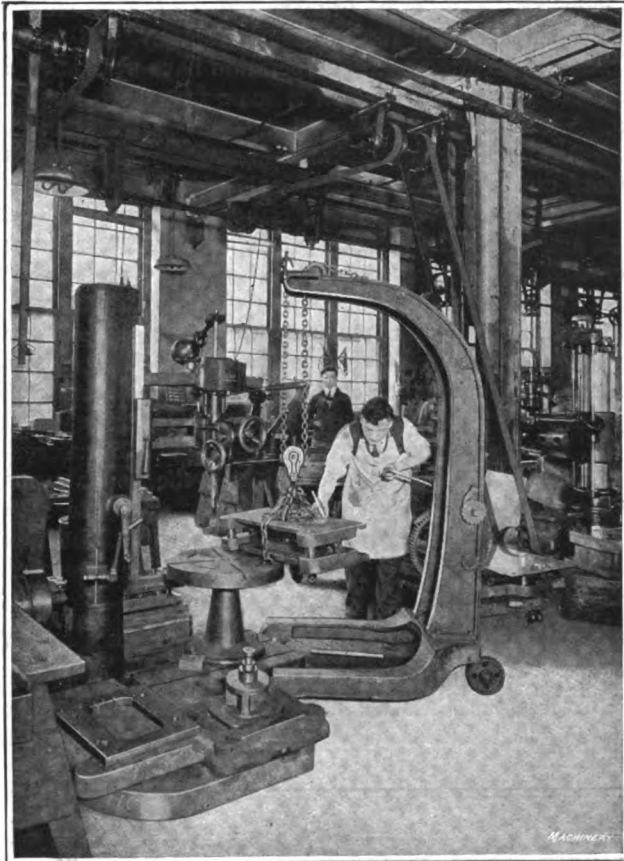

Fig. 3—In setting up heavy pieces on machine tools, it may be difficult to handle work on a traveling crane, due to the inability of that kind of equipment to reach the desired point. This illustration shows a view in the Cadillac Motor Car Co.'s factory, where a portable crane built by the Franklin Machine Works, Franklin, Pa., is engaged in setting up work on the table of a radial drilling machine

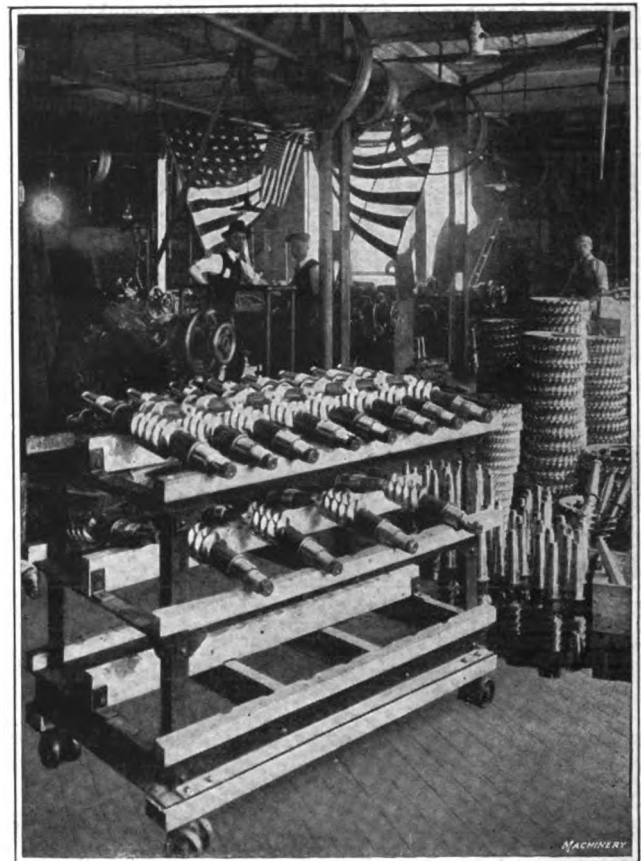

Fig. 4—Worm drives for rear axle transmissions are made in large quantities at the plant of the Timken-Detroit Axle Co. Of course, these worms and the worm-shaft bearings, etc., are carefully machined and precautions must be taken to prevent damage through one worm striking another. This is accomplished by the use of special trucks with "cradles" in which the worms are held without danger of damage

to avoid the congestion which is likely to arise when the same aisles have to be used by trucks which pass in opposite directions.

One simple expedient, which is capable of producing a marked increase in efficiency in handling materials and products on trucks, is the maintenance of open aisles in all departments and in passageways connecting different departments of the plant. This point is often entirely overlooked by the management of factories which otherwise show ample evidence of efficiency. Such shops frequently have the aisles so cluttered up with a heterogeneous collection of materials, products and tools that it is virtually a case of "breaking a trail" for a truck that must be pushed through the shop. In many factories where a decision has been reached in favor of maintaining open

by angle irons, so that they are not subjected to damage by truck wheels, etc. They are painted white so as to be always visible, and have been found an effective means of preventing minor accidents and delays caused by trucks intruding upon space in the factory reserved for manufacturing work, and also of preventing machine operators from pushing boxes of castings or partially finished work out into the aisles where they block the progress of trucks carrying work from department to department.

Rearrangement of existing plans is well worth while. We have in mind one small factory engaged in the manufacture of machine tools which has recently increased its output over 50 per cent by completely rearranging the lay-out of departments and equipment, without buying any new machinery or hiring more men. But in cases



where complete new plants are designed, built and equipped for the production of a specified quantity of work, it is possible to obtain far greater efficiency than where existing factories are remodeled with the view of increasing efficiency. This is because, under the best conditions, rearrangement of an existing plant must leave many features that could be greatly improved, while in case an entire plant is laid out on a drawing board before starting construction, every detail can be carefully considered and means provided for overcoming many difficulties which are foreseen by the industrial engineer as a result of his experience with similar problems in other factories. In the automobile industry we probably see some of the best examples of efficient methods of handling work. Viewing the subject broadly, there are several explanations which

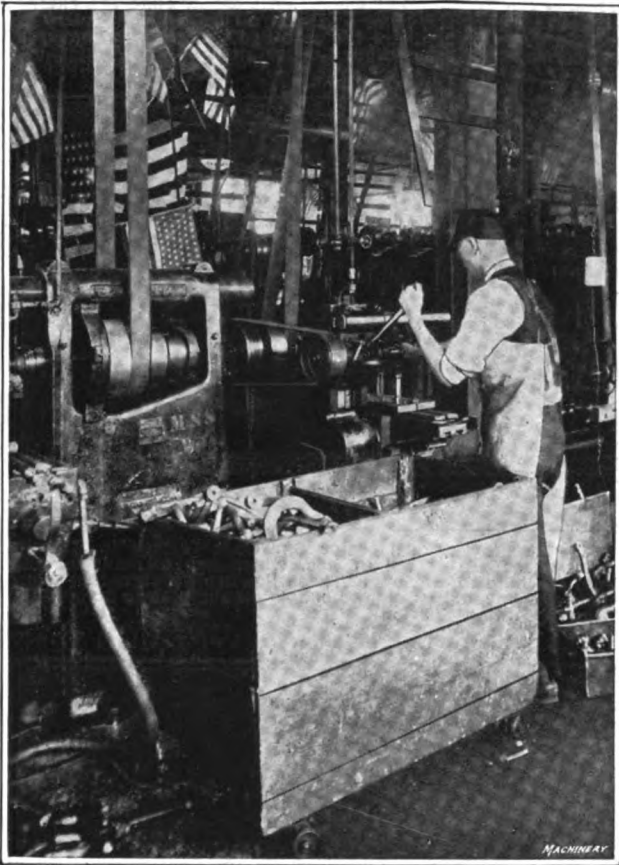

Fig. 5—Forgings, castings, etc., delivered to machines for a specified operation must be kept separate from those on which the operation has already been performed. One truck for blanks and one for machined work take up considerable space. A better method is to have one truck with a partition dividing the space into a compartment for blanks and a second compartment for finished work (Timken-Detroit Axle Co.)

may be offered for the high degree of efficiency which has been attained in this industry, but they may be narrowed down to the fact that many of these companies have been organized and their factories have been built to provide for securing a specified rate of production, and in this industry, as in no other, has the advice of the best industrial engineering talent been taken in regard to the installation of time and labor-saving appliances. A plant that is required to make and assemble the parts to turn out several hundred complete automobiles a day is certainly faced with a great task, and were it not for the fact that the automobile industry has taken advantage of every possible means of increasing production, it would have been a physical impossibility to meet the demand for motor cars that has existed during recent years.

### Methods of Transporting Work

Hand-operated trucks or power trucks are used for the miscellaneous transfer of material from point to point in a factory, and their chief virtue lies in the fact that no fixed course need be followed. Hand-operated trucks of the plain or platform type may be either pushed or pulled, and when they are pushed it is desirable to have some form of buffer at the front to provide for opening swing-

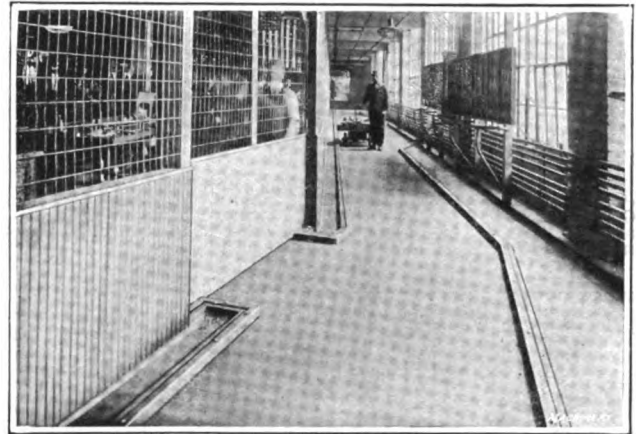

Fig. 6—In order for trucking to be done efficiently, it is of absolute importance that all aisles in the factory be kept open. Instead of a paint line down each side of the aisle, the Timken-Detroit Axle Co. uses 2 x 4 in. timbers protected with angle irons. These effectually prevent trucks running out of the aisles

ing doors without delay. This buffer should be of a curved shape, so that if the truck gets into a jam, the buffer will assist in guiding the front through a narrow passage. A curved buffer also prevents damaging swinging doors in the shop, which are often pushed open by bumping the truck against them. For short hauls, hand-operated trucks are most satisfactory because of their lower cost and small upkeep charge; but in case heavy

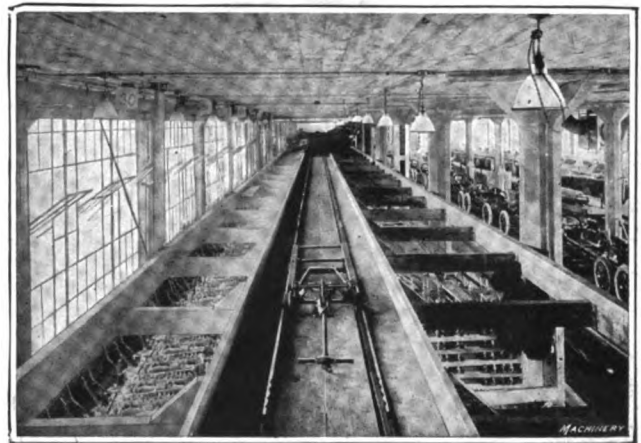

Fig. 7—The Palmer-Bee Co., of Detroit, Mich., installed conveyors and other equipment for handling work at the plant of the Paige-Detroit Motor Car Co. A rack was designed for storing automobile bodies, over which they are carried by a special elevating truck

loads have to be hauled considerable distances, it is better to use power trucks, and these are ordinarily made of the storage battery type. In the plant of the Timken-Detroit Axle Co. and elsewhere, an alternative for power trucks is provided by having platform trucks arranged with couplings, so that they may be connected in trains and pulled by an "engine" which is equipped with the motor of a discarded Ford automobile. Such trains of cars are pulled

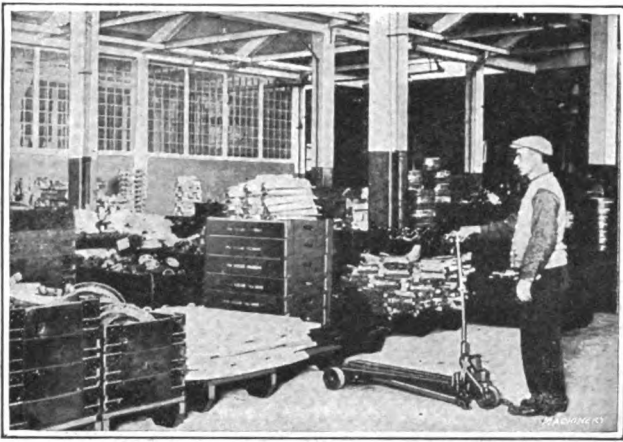

Fig. 8—Telescopic boxes on platforms are used by the Pierce-Arrow Motor Car Co., Buffalo, N. Y., in connection with Cowan elevating trucks. Box sections are of standard size and can be built up as required. Note saving of floor space made possible

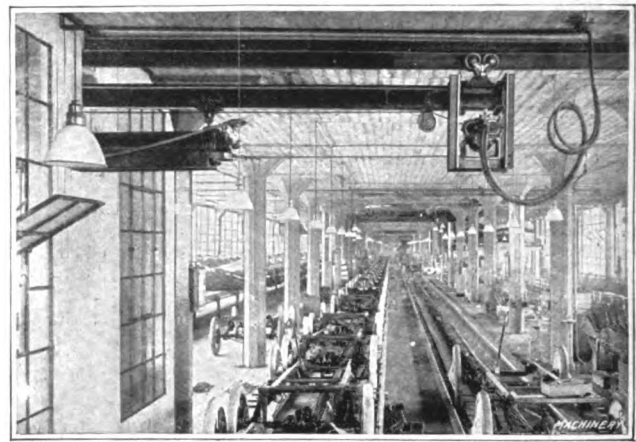

Fig. 11—In the trolley rail extension (Fig. 10), the air cylinder actuates the hoist and the pneumatic motor runs the extension out so that the hoist can pick up its load and carry it back into the shop, where the auto body is put on a conveyor and carried to the assembling department

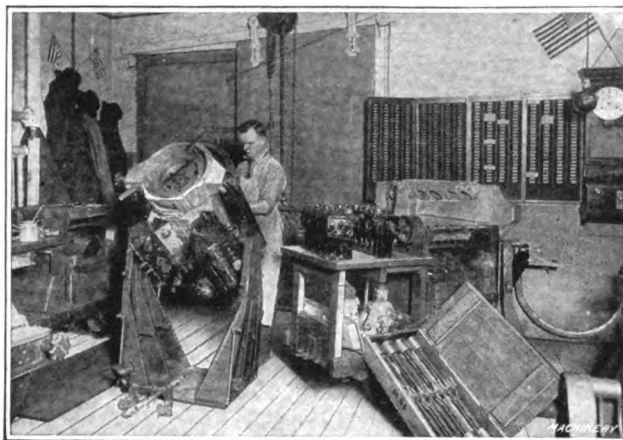

Fig. 9—Time is often lost through assemblers having to make trips to the storeroom to obtain missing parts. The Cadillac Motor Car Co. has overcome this difficulty by constructing trucks with individual compartments for carrying a complete set of parts for a motor

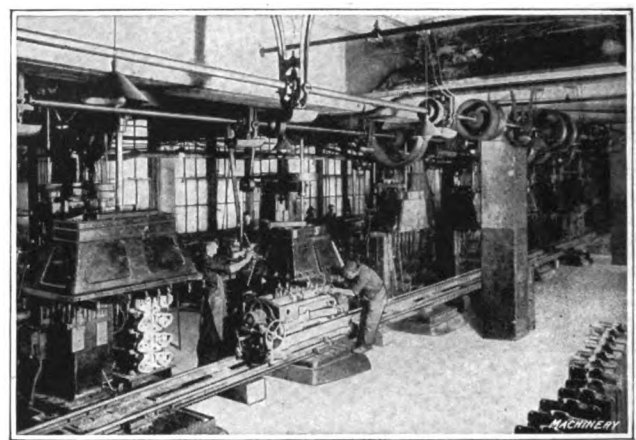

Fig. 12—At the Packard Motor Car Co.'s factory in Detroit, crank cases are drilled in jigs, which run on rails leading from machine to machine. These jigs are supported on trunnions and have index pins to enable all surfaces to be brought into the drilling position

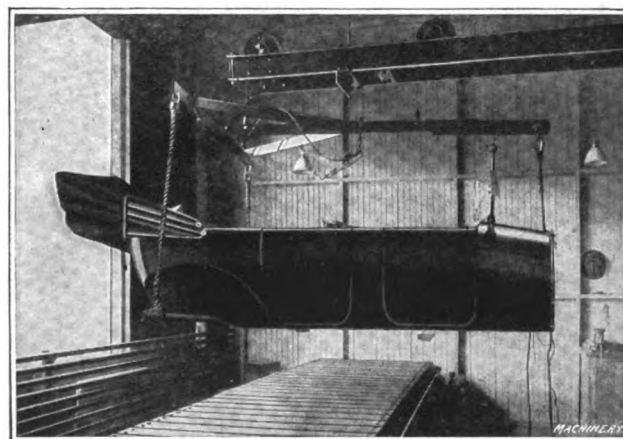

Fig. 10—In some cities municipal regulations prohibit extending a beam out over the roadway to support a trolley. The Palmer-Bee Co., of Detroit, Mich., made a movable trolley for the Palge-Detroit Motor Car Co., which can be run out over the road to pick up auto bodies

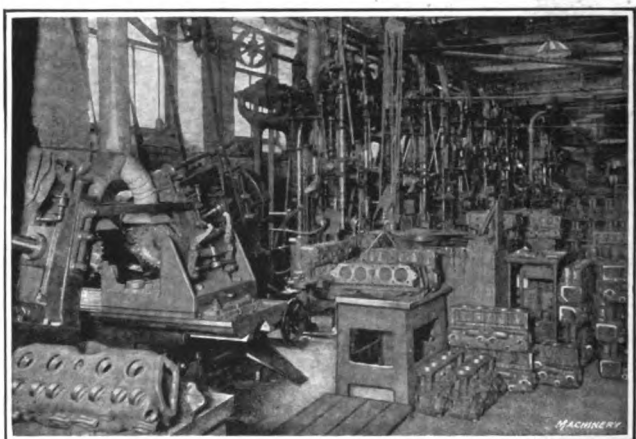

Fig. 13—In the cylinder department of the Cadillac Motor Car Co. there is a stand between each pair of machines, of the same height as the machine tables, so the operator does not have to stoop. Castings are swung from machine to stand and thence to next machine

from the forge shop to the first machine shop—a distance of about one-eighth mile—and enable material to be handled much more rapidly than it could be with hand-operated trucks.

#### Handling Work of Assembling Department

In plants engaged in the manufacture of complete products, that is, in machining parts and assembling them ready for shipment to the user, there is probably no better

method of handling than sending completed parts to what is generally known as the "finished stores" department, from which they are drawn on requisition by the assembling department as fast as they are required. The introduction of various profit sharing plans in industrial plants has been extremely valuable through its tendency to unify the interests of employer and employe, as both classes benefit through any increase of production which is made

possible. To facilitate the handling of materials and the performance of machining operations as far as possible, and to make a corresponding increase in the earnings of men and the profits of employers, most large manufacturing plants have established what are known as planning departments, which employ engineers whose duty it is to devise time and labor-saving methods.

Much has been accomplished in this way, but there is

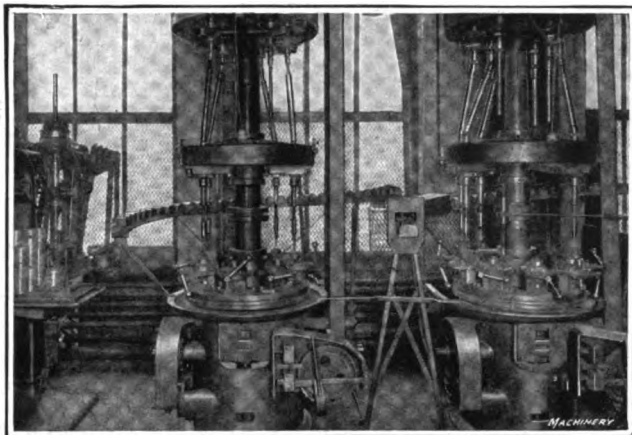

Fig. 14—In performing a sequence of operations on pistons, the Cadillac Motor Car Co. uses a trough in which the pistons are rolled from machine to machine. When an operation has been completed, the piston is removed from the machine and placed in the trough

probably no one step which has effected greater savings in the cost of production than the development of what is known as the progressive method of assembling. This was first employed in the assembling of parts to form complete motor cars, and as practiced in automobile factories, it consists of putting the automobile frame on a traveling conveyor which runs the entire length of the assembling shop. This conveyor carries the frame along, and stationed at intervals along the track are gangs of

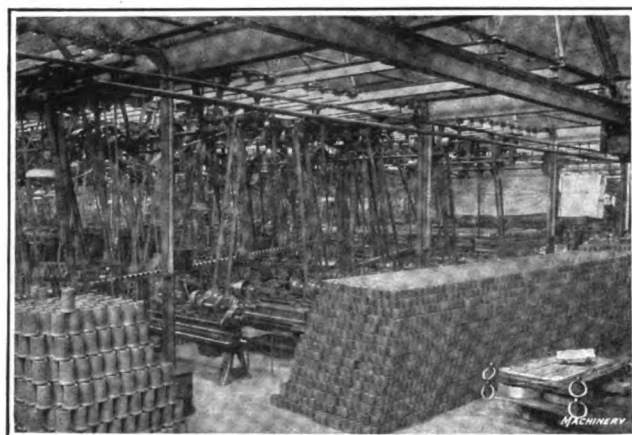

Fig. 15—Troughs are also used for carrying cylindrical work, such as pistons, from machine to machine in the plant of the Ford Motor Co. This illustration shows a somewhat different arrangement from that illustrated in the Cadillac factory. An idea of the enormous rate of production in the Ford shops will be gathered from the stack of pistons shown in the foreground of this illustration

men who perform specified parts of the work of assembling. These men are kept constantly supplied with parts, which they put in place on each car as it passes their station; thus the conveyor constitutes a pacemaker which stimulates activity on the part of the men and keeps them working at top speed.

Practice varies in the method of handling progressive

assembling in different automobile plants. In some cases the automobiles which are constantly getting nearer the completed condition are moved along the track by a power-driven conveyor, as previously mentioned, while in other cases each frame supported by the axles and wheels of the automobile is run along the track as fast as the different groups of men are through with their task. The former is usually the better method, as when

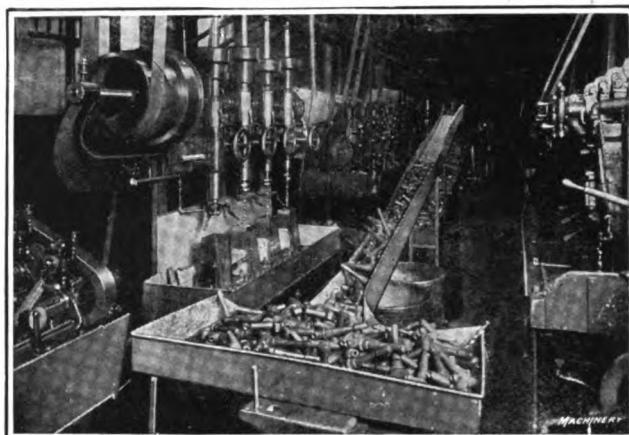

Fig. 16—In the Ford Motor Co.'s plant, application of work-carrying troughs is not limited to the handling of pieces of cylindrical form. Many small parts are carried in this way, but it is necessary to have a considerably greater pitch where the work must slide instead of roll in the trough. This idea is simple and could be used to excellent advantage in handling a great variety of work

the work is moved along by hand the personal equation becomes the determining factor in establishing rates of production, so that much of the possible benefit of the plan is lost.

An alternative method is employed in assembling automobiles in the plant of the Studebaker Corp., Detroit, Mich. Under this plan the cars are all connected to a conveyor, which, instead of running continuously, is

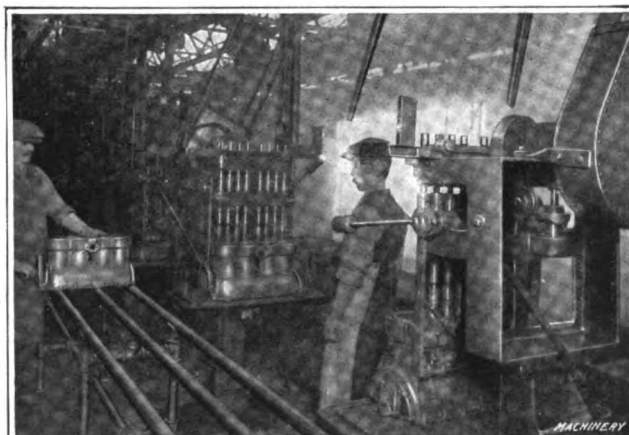

Fig. 17—For handling pieces that are too heavy to slide in troughs, and where it is only required to transport the work a short distance, rails are set up in the Ford Motor Co.'s factory, along which the work can be slid from machine to machine. This saves lost production during late hours of the afternoon which would otherwise be caused by machine operators becoming unduly fatigued

moved intermittently by a man who is stationed on a bridge at the head end of the track and operates control levers to move the cars forward one station as soon as the assembling operation has been completed by all the men along the track. Each station is given a number, and a push button is provided by which a signal is sent to the man on the bridge that the work of assembling at

that station has been completed. These signals consist of electric lights which glow as soon as the push button is pressed and show the numbers of the stations that have completed their work.

When all the lights are on, the man on the bridge immediately throws over his control lever and advances the automobiles on the assembling track to the next station. This man keeps a record of the order in which assembling operations are completed at the different stations and the number of men at each station is regulated according to the complexity of the work, the idea being to have all of the assembling operations completed at the same time. Should it happen that a given station is conspicuously behind time, an investigation is made to find whether the men at this station are taking an unnecessary amount of time or whether conditions of the work justify an increase in the time required for assembling. Upon the result of this investigation a decision is reached either to supply one or more additional men to help with the work or to replace those men who are found to be taking too much time in the performance of their task.

Mention has already been made of the fact that the progressive method was developed for the assembling of complete automobiles, but its advantages have become so conspicuous that automobile manufacturers are now using it in many other kinds of work. For instance, motors, rear axles, clutches and many other parts are assembled by the progressive method.

The Palmer-Bee Co., Detroit, Mich., had installed a number of successful conveyor systems in the Packard factory, and suggested that it would be entirely feasible to apply the progressive method of assembling in handling the clutches. The result was that stands of the same type as those originally used, except that they are made lower

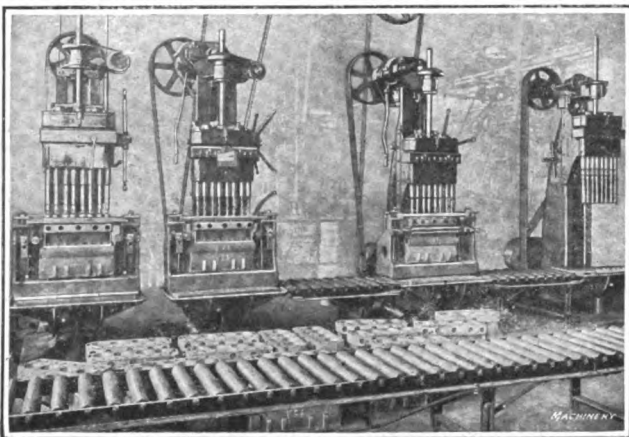

Fig. 18—Sometimes it is feasible to design jigs and fixtures in which work may be held for the performance of a number of machining operations. This illustration shows such jigs in use in the Maxwell Motor Co.'s shops in Detroit, Mich. The work and jig are pushed along from machine to machine on a roller conveyor, the operator following the jig right down the line of machines.

on account of being supported on the conveyor, were placed on the power-driven conveyor, along which groups of men are stationed to perform the assembling operations. These men are constantly supplied with the parts they are required to put together, and as the conveyor sets the pace, the rate of production in handling this work has been greatly increased.

#### Organization of Assembling Methods in Other Directions

Lack of organization in handling the work of the assembling department probably offers a better opportunity

for unconscientious employees to waste time than is the case in any other department. This is due to the fact that in assembling, certain parts are likely to be missing and this presents an opportunity for the assembler to go to the storeroom for parts and take a lot of time in getting them. With the view of overcoming trouble from this cause, many manufacturers have organized their work of assembling in such a way that a complete set of parts for a given unit is carefully made up in the finished stores department and checked over to see that nothing is missing:

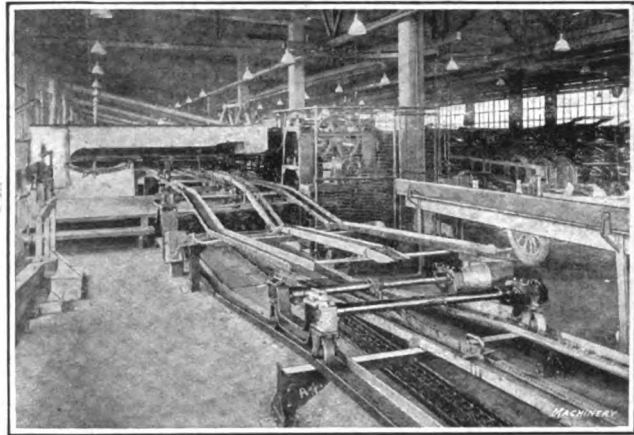

Fig. 19—Here we show a conveyor system installed by Palmer-Bee Co., of Detroit, Mich., for handling automobile frames in Paige-Detroit Motor Car Co.'s plant. Empty trucks return through tunnel and are caught by a hook on the conveyor. They run back over hinged section of track and receive frames from trolley system. One truck is coming up the incline and another is on upper level of track with a frame on it.

this set of parts is then sent up to the assembling room and can be put together without delay. A case in point is seen in the motor assembling department of the Cadillac Motor Car Co., Detroit, Mich. This firm has refused to adopt the method of progressive assembly because its engineers hold the view that a forced rate of production must, of necessity, lead to turning out work which is likely to be found unsatisfactory in service. Every effort has been made to facilitate the work of assembling by keeping the men constantly supplied with the parts they need and by every other means that cannot exert a harmful effect upon the quality of the work produced. One important step in this direction consists of providing trucks that are furnished with trays divided up into compartments for all the parts of a motor. These trucks are sent empty to the finished stores department, where a complete set of parts for a motor is loaded into the truck. By having the trucks subdivided into trays and compartments it is an easy matter for the men in the storeroom to check up the parts to see that nothing is missing. Then when the truck goes up to the assembling room there is no chance of delay through lack of parts. Work is further facilitated by providing stands mounted on joints that permit the motor to be swiveled into any position that will be found most convenient for putting each part into place.

(The second and concluding instalment of this article will appear in the October issue of The Hub.)

#### Drum to Build Buick Bodies

Charles Drum, factory manager of the Springfield Body Corp., Detroit, has resigned. On September 1 he will take charge of the body department of the Buick Motor Co., Flint, Mich., which is housed in what is known as Buick Plant No. 4.



### A Farm Truck Body for a Ford Car

The design of body shown in the illustrations can be used for farm trucking, as the body shown is that of an ordinary farm wagon mounted on a Ford chassis. The Ford truck has a wheel base of 125 in., and a tread of

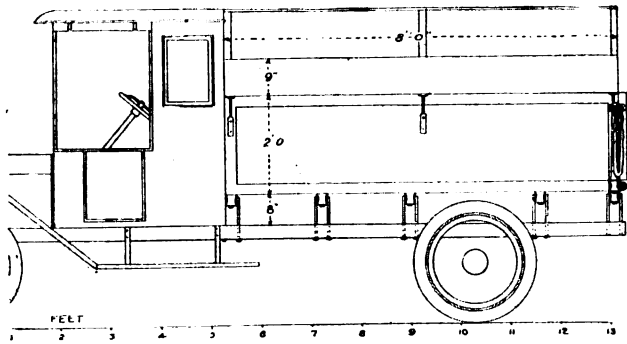

Fig. 1

56 to 60 in. Fig. 1 shows a side view, Fig. 2 is a plan view, Fig. 3 a front view, and Fig. 4 a rear view.

The size of the sills of the body is  $2\frac{1}{2} \times 2\frac{3}{4}$  in. front, and  $2\frac{1}{2} \times 4$  in. at the rear. There is one center crossbar  $2\frac{1}{2} \times 3$  in. All of the crossbars are well mortised into the sills. The floor boards are  $\frac{1}{2} \times 4$  in., and are rabbeted into the end crossbars. The front, rear, and center posts are  $2\frac{1}{2} \times 2\frac{1}{2}$  in.

There are also two side panels made from  $\frac{1}{4}$  in. hard

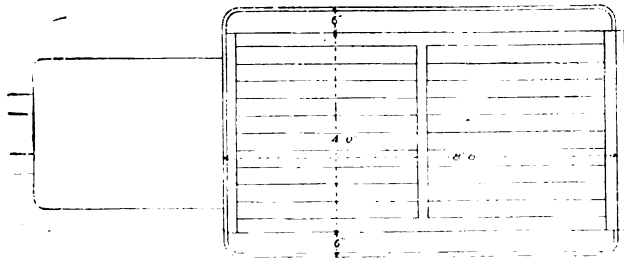

Fig. 2

wood. The top rails are  $2\frac{1}{2} \times 2\frac{1}{2}$  in. by 8 ft. long. The extension top, or barrel or box seat, is 6 in. wide by 9 in. high, and is made of  $\frac{1}{4}$  in. stock, which in turn rests on the top rails, secured thereto by six iron braces. The extension top is round at the four corners, as shown in the plan view.

The body rests on five crossbars, which are  $3 \times 8$  in.,

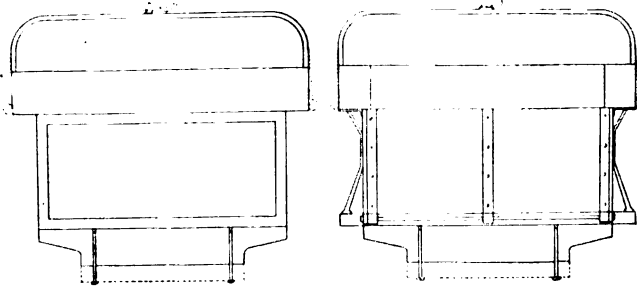

Fig. 3

Fig. 4

the five crossbars resting on the chassis frame, and secured thereto by U bolts as shown in Figs. 1, 2 and 3.

A simple method of placing the canvas covering on the load is accomplished by placing a roof bow at each end, and one at the center, with a roof board, lengthwise with

the body, secured to the three bows at the center. The canvas is nailed to this roof board at the center and dropped down at each side, covering the entire contents of the load. At the bottom on each side of the canvas covering is a long pole, answering as a weight and keeping the sides down. When the canvas is not in use it can be rolled up as shown by dotted lines in Fig. 4, which is a great improvement over the old way of fastening down the canvas.—Blacksmith and Wheelwright.

### Motor Vehicles in the Moncton District

Practically all the leading makes of American passenger cars are now sold in Moncton, New Brunswick, Canada, several of them being the products of branch factories located in Canada. Other than these, says Consul F. Verne Richardson, there are few cars sold locally, English, French, and Italian manufacturers not having met with any marked success in their attempts to introduce their lines. The lowest priced car on this market sells for about \$500 and the highest for about \$3,000, but there is little market for the latter, the average buyer not caring to spend more than \$1,000 to \$1,250.

The customs duty on cars from the United States is 35 per cent, with an additional war tax of  $7\frac{1}{2}$  per cent.

The five passenger body is the best seller, painted black or dark blue, with japanned or nickel fasteners. The one-man mohair top is preferred.

Motor vehicles of exclusively commercial types are not in general use in the Moncton district. The winters are long, with much snow and ice, during which all heavy trucking is done on runners. Nevertheless there are a few light motor trucks in service, the  $1\frac{1}{2}$  ton size being probably the leader in popularity. The Provincial government is using ten heavy-duty American trucks in its road repairing work.

### Nash Appoints Wilson Assistant Manager

J. T. Wilson has been appointed assistant manager by the Nash Motors Co., Kenosha, Wis. He first worked under Nash in 1906, as a most minor clerk in the Durant-Dort Carriage Co., of which Nash was vice-president. In 1910, when Nash became the Buick president, Wilson had reached the position of purchasing agent. Three years later he was head of the Durant-Dort motor division when Nash called him to the Buick Motor Co. to act as purchasing agent, and since then he has been continually associated with Nash, having gone over with him into the Nash Motors Co. when it was first formed to take over the Thomas B. Jeffery Co. Since September last he has been closely associated with C. W. Nash, president of the company, in the work of organizing the manufacturing schedules.

### Silver and Appersons Plan Silver-Appersons

C. T. Silver, the New York City dealer and distributor, has formed a combination with the Apperson brothers, of Kokomo, Ind., for the design, production and sale of what will be known as the Silver-Apperson car. The first model is to be exhibited at the New York show in January. The car will be an eight. Silver is an aggressive salesman and is a genius in the creation of special bodies. He has successively handled Peerless, Overland and Chalmers cars, and now handles the Dort.

## Specifications for U. S. Army Ambulance to Fit Standard Ford Chassis

Working drawing on opposite page

1. General Provisions—The materials called for must be of the best and highest grades mentioned in the specifications, and the work must be thoroughly and faithfully executed in all its parts.

2. Inspection—The material and workmanship will be inspected as work progresses, by a representative of the Medical Department.

3. Lumber—Special care must be observed that all wood is well seasoned.

4. Unless otherwise distinctly stated in the body of these specifications the kinds of lumber used for different purposes will be as follows:

5. All wood stock used in the body proper, side posts, sills, rails and corner posts to be of ash of first quality. Side panels to be  $\frac{1}{4}$  in. thick, waterproof "Vehisote" composition. Front end panel to be  $\frac{3}{8}$  in. thick of same material as side panels.

6. Top bows to be of good quality ash or oak.

7. All cross bars front and rear sills to be of best quality hard wood (ash or maple or birch).

8. Side boards, cross bars to be reinforced by angle irons of best quality of steel and of sufficient strength to carry 100 per cent overload. All other irons to be of open-hearth soft American steel unless otherwise specified.

9. Best American soft iron for clips, bolts and rivets. All fastenings of steel or wood are required to be bolted, screwed or riveted to uprights.

10. Paints and oils of best quality of their respective kinds and strictly pure.

11. All side posts of first quality ash fastened to composition paneling with screws.

12. Water tank to be 20 gage galvanized iron with cap for filling and  $\frac{1}{2}$  in. spigot opening into tool box on the left side of body. Tank to be made of proper size, 5 gal. capacity, and suitable to fit in the panel below the side door on left side of body.

### Body

1. Capacity—Three persons prone in the rear of driver's seat. Two litters on the floor of car and one carried on folding angle iron and hood rack in the center of the body. Driver's seat to be wide enough to carry two passengers in addition to the driver if necessary. Inside over all measurements of the body to be 7 ft. 6 in. long, 4 ft. high in the center and 4 ft. wide. Tail gate to be made of suitable hard wood 22 in. high, suitable pockets to be cut in same to allow litter handles to protrude, these pockets to be covered with canvas. Top of body to be slatted with ash slats with not more than 3 in. space between same. Floors to be of first grade yellow pine flooring. A side door 14 x 20 in. to be provided in each side of the body directly back of the driver's seat. Said door to be securely hung on two hinges. Provide a slatted seat 36 in. wide in each side of the body immediately back of the driver's seat, these seats to fold up when not in use. A mud guard to be provided on both sides of the car running the full length of body.

2. Bottom frame work—A  $1\frac{1}{2}$  x  $1\frac{1}{2}$  x  $\frac{1}{8}$  in. angle sill on each side of the body on the ends of the cross sills. All cross sills to be also reinforced by  $\frac{3}{4}$  x  $\frac{3}{4}$  in. angles. Tail gate to be fastened to the rear sill by two wrought iron strap hinges.

3. All studs and posts to be of ash  $1\frac{1}{4}$  in.

4. Top slats to be of ash  $1\frac{3}{4}$  x  $5/16$  in. nailed to bows 1 in. apart around bend, and 3 in. apart over the flat part of top.

5. Six ash or oak bows  $\frac{3}{4}$  x  $\frac{7}{8}$  in. halved and screwed to the horizontal side rails of the body.

6. Paneling on side of driver's seat, all medicine and tool boxes to be of bass wood, poplar or ash. Each of the tool boxes to have a padlock.

7. Step on rear tail gate to be of 1 in. angle iron around the center pocket.

8. Litters when folded to be carried on the floor held against the sides of the body by an iron at the front end and the tail board pocket in the rear.

9. The front panel to be protected from the handles of the upper litter by two 20-gage steel plates, each held in place by four wood screws.

### Trimnings

1. Cushion for driver's seat to be made in two pieces, pad style, and covered complete with black imitation leather.

2. Curtains to be made of Tan Textol, waterproof, and mildew duck.

3. Curtains on each side of driver's seat to have suitable size celluloid lights and to be fastened securely by brass grommets and curtain fasteners. Curtains to be hem stitched all around. All edges around the lights to be carefully sewed back to prevent ravelling.

4. Cover over driver's seat to be supported by a standard Ford top bow and sockets. Curtain in front of driver to be held in place by two webbing straps and fastened to the side curtains and cowl with grommets and curtain fasteners.

5. Curtain in the rear of the car to have a pocket of sufficient size to cover the handles of the upper litter.

6. Hand straps to be provided on the roof of the car in such a position that the patient in the upper litter can reach them conveniently for support. Provide three webbing straps on the right-hand side of the body to hold one extra tire. Provide webbing straps inside the body to hold upper litter rails against the side of body when not in use.

All wood work to be primed with a coat of oil primer colored to make a background for the finished coat. Outside to be painted one coat of olive green, inside one coat of dark cream color. All iron work to be japanned two coats. All paint to be a good outside waterproof paint.

In the panel of each side door place a caduceus 6 in. high in maroon, laid on a background of aluminum leaf. In the center of the second panel  $2\frac{1}{2}$  in. from the top rail place a Red Cross 8 in. square on aluminum leaf. Each bar of cross to be 6 in. long and 2 in. wide. Four inches below this 8 in. square the letters "U. S." are to be laid on aluminum leaf. Full block letters  $4\frac{1}{2}$  in. high with a 1 in. square period after each letter. All work to be done in a workmanlike manner.

### Babcock to Go to France as Major

George de A. Babcock, production manager of H. H. Franklin Mfg. Co., automobile manufacturer, Syracuse, N. Y., has been commissioned a major to go to France in the supply division of the ordnance section of the U. S. army. He is on an indefinite leave of absence from the company.



# U. S. Army Ambulance to Fit Standard Ford Chassis

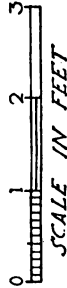
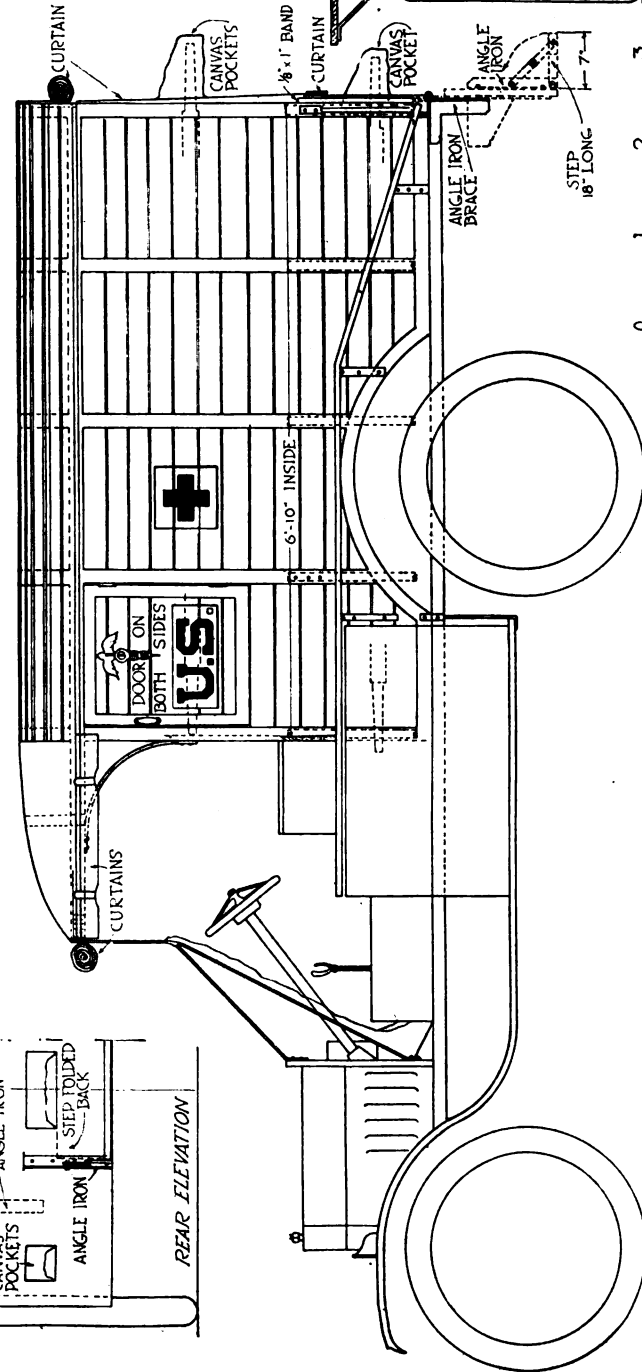
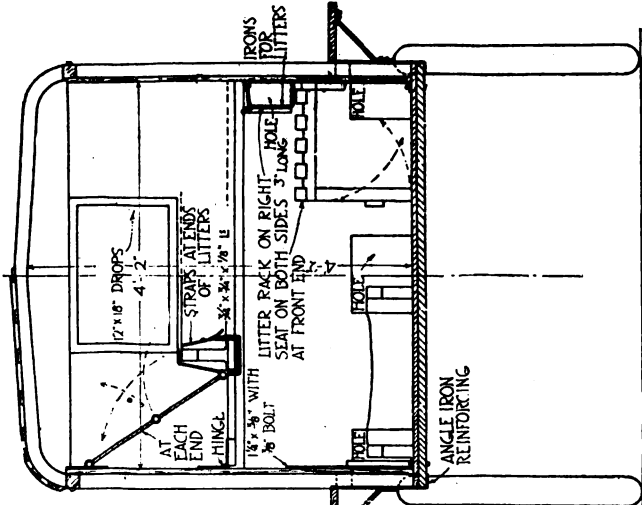
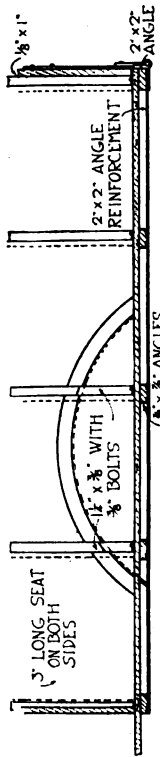
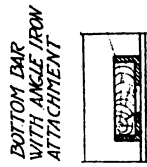
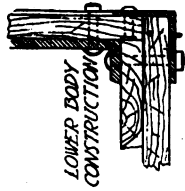
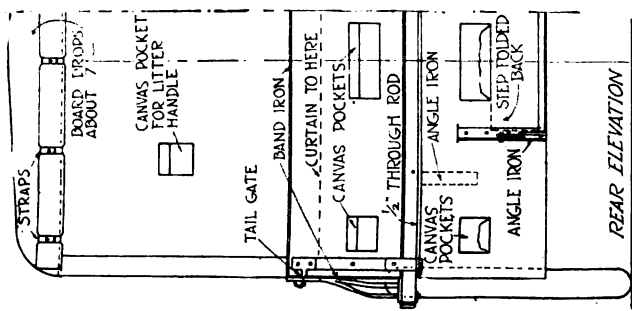

### Truck Unit Organized in New York

The New York Truck Manufacturers' and Dealers' Association has been organized in New York City for the special purpose of considering problems of those engaged in manufacturing and dealing in attachment units to convert passenger cars into commercial vehicles.

At the organization meeting some 30 members were secured. L. Willard Mulford, of the Mulford, Haas Co., Brooklyn, N. Y., was elected president; A. S. Rampell, of the United Auto Dealers' Mfg. Co., vice-president; F. R. Valpey, of Graham Bros.' Sales Co., secretary; Frederick G. Cole, of Cole & Dickerson, treasurer. The objects of the association include plans for regulating sales and service for standardization of commercial bodies, etc., and the elimination of existing trade evils.

### Electric Vehicles in Bradford

The fact that inferior grades of gasoline are now selling at 80 cents a gallon and consumers are strictly rationed as to the amounts obtainable has led to a large demand for electrically-driven vehicles, writes Consul Augustus E. Ingram, Bradford, Eng. The demand for commercial vehicles, such as delivery wagons, trucks, and lorries, is especially noteworthy. There is said to be an opportunity for good electric road lorries, trucks, and wagons of all types and bodies, electric tractors for road and rail, industrial trucks, motor busses, and passenger vehicles. Catalogs and descriptive literature of electric vehicles are desired by the Bradford consulate and will be placed in the hands of interested dealers.

### Grinding Wheel Balance

Howard W. Dunbar calls attention to the need of perfect grinding wheel balance in Grits and Grinds, asserting that probably nine-tenths of all trouble with cylindrical grinding machines is caused by the efforts of the operator to obtain good work by tightening the boxes so as to prevent an out-of-balance wheel causing marks on the work. Out-of-balance wheels set up vibrations throughout the whole machine, which cause chatter marks in the work; they are more likely to break than wheels in balance; they wear out the spindle boxes rapidly; and are more destructive to diamond truing tools, requiring more frequent dressing. Out-of-balance wheels, therefore, are more expensive than wheels in balance because of more rapid wear and their deteriorating effect on grinding machinery.

### Raise Ford Plant Rating \$35,000,000

The state board of review has raised the value of the Ford plant \$35,000,000 above the township board rating. The township board rated the plant at \$42,500,000 and the state board raised it to \$77,500,000. The board also raised the township board's valuation of the Dodge plant from \$7,500,000 to \$13,000,000.

### Anderson Granted Body Patent

The Anderson Motor Co., of Rock Hill, S. C., has patented a motor vehicle body which may be converted from a two-passenger into a five-passenger vehicle. The patent was taken out for a convertible sport body, and is No. 1,233,957.

### New "Nash" Car

The purchase of the Jeffery factory by C. W. Nash last August immediately gave rise to persistent rumors that the Nash Motors Co. would undoubtedly bring out a new Nash car which would reflect the ideals of Mr. Nash and his organization of automobile experts. A new Nash car has now been designed and built, and its specifications and price will soon be announced. Thirty Nash distributors were recently shown the new car. It is generally believed that this car will sell at well under \$2,000. The 671 Jeffery model will be continued as the seven-passenger car of the Nash line, probably bearing the Nash name plate.

### Frank Ansted Heads Lexington

Frank B. Ansted has been elected president of the Lexington-Howard Co., Connersville, Ind., succeeding his father, the late Edward W. Ansted. As general manager of the company, the new president has been the active head of the company for some time. Emery Huston, advertising and assistant sales manager, has been elected second vice-president, filling the place opened by Ansted's elevation, retaining his former duties; J. E. Huston remains as first vice-president, and Arthur A. Ansted, a brother of the new president, is added to the directorate to succeed his father.

### New Canadian Vehicle Company

The Dominion Carriage Co. has been organized and incorporated at Montreal, Canada, with a capital stock of \$500,000 to manufacture carriages of all kinds, also automobiles. A large plant will be constructed. The promoters of this new enterprise are P. T. Legare and J. H. Fortier, who are the principal owners of the large wholesale implement and vehicle concern, P. T. Legare, Ltd., Quebec. The manager of the Dominion Carriage Co. is Fred Arthur, of Montreal, who for some time has been general manager of the Heney Carriage & Harness Co.

### Opening for Automobiles in Guayaquil

Consul General Frederic W. Goding reports from Guayaquil, Ecuador, that some of the principal streets of that city have recently been paved and that American manufacturers of automobiles should take advantage of the increased demand for motor cars that will follow. A list of firms that would be interested in such agencies was transmitted, a copy of which can be obtained at the Bureau of Foreign and Domestic Commerce or its district or co-operative offices by referring to file No. 90007.

### Body Imports Barred by Australia

Under the decree of the Luxury Board the importation of complete motor vehicles into Australia is prohibited, although manufacturers may continue to ship chassis without bodies. All complete motor vehicles now in transit can enter Australia, the ruling applying only to shipments made after August 13. Less than 20 per cent of the American-built motor vehicles imported into Australia have been shipped without bodies.

**Close-Coupled Body**

The close-coupled body, a cross between the touring and runabout, is a conception that has always had a promising look to the prospective automobile buyer. From the beginning manufacturers have brought out from time to time a few bodies on this plan and they have always been successful, but it remained for the time when the divided front seat with the aisle between to make it a practical success.

This style of body is applicable for the short wheelbase chassis and the early body models of this class had four doors, for which there is not sufficient room. The difficulties of entering and leaving the rear compartment

fault has been to make the bodies high looking by the use of the cowl at the rear of the front seat. In spite of these drawbacks this body has increased in numbers and is now a permanent type and it is reasonable to predict that it will supersede the runabout for all except the sport type or so-called semi-racing body.

Economy of operation and the lower initial outlay compel many to buy a small car, at the same time the needs to which this car are to be put will cover as large, if not a larger field, than the owner of a large car will require. The most suitable body for a small car is a difficult problem; it must be light in weight, not too expensive in outlay, it must be suitable for business or pleasure, and very

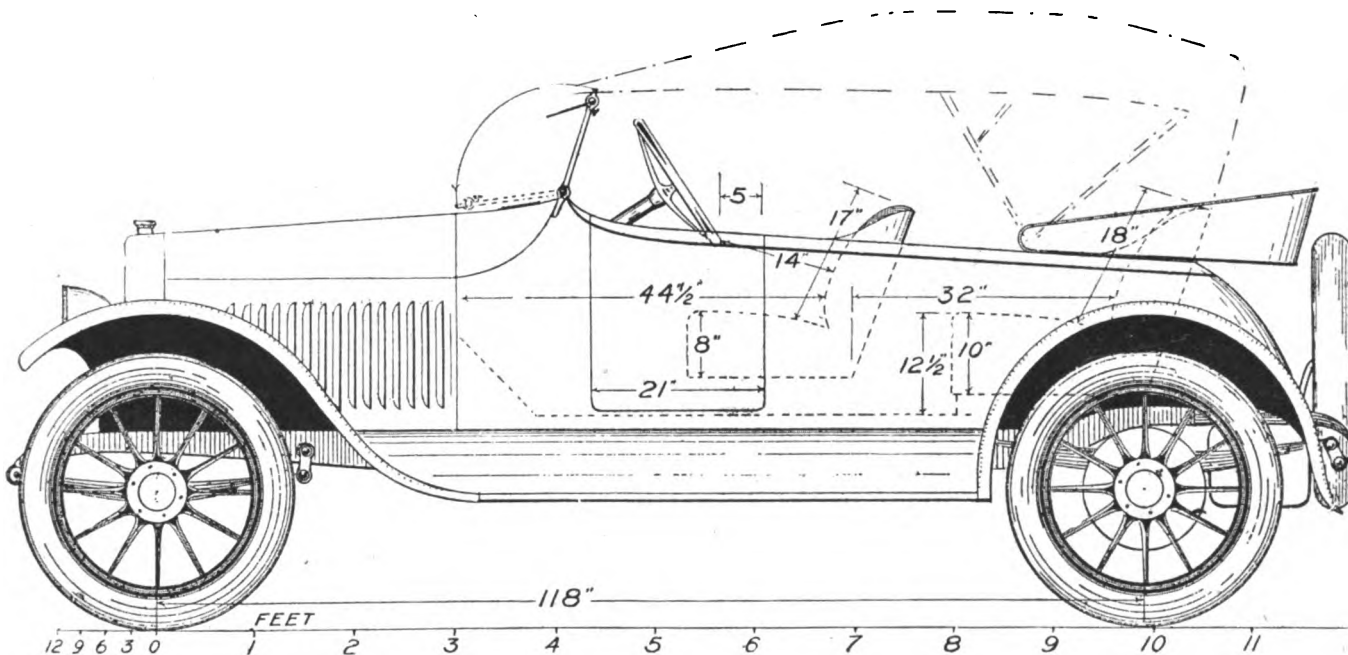
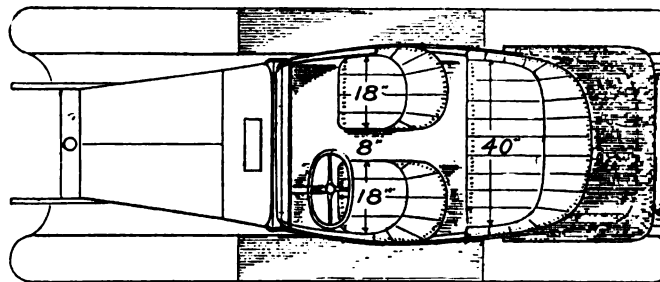

**An Attractive Close-Coupled Four-Passenger Body Designed by George J. Mercer**

This body is intended for all year service. The body is designed for 118 in. wheelbase, and is as small as will be practical. If a slightly larger wheelbase is used it will improve the design by giving it that long sweep that is so much sought after.

through a cramped door space prevented this body from becoming more popular, but with the advent of the divided front seat, many forms of this body have been introduced, of which the so-called clover leaf is the most numerous.

The clover leaf, which was originally a three-passenger job and strictly a runabout, has been increased in size to accommodate four people; in the majority of these, however, two mistakes have been made, the rear seat is not far enough back to allow full grown persons to sit comfortably; in fact, the three-passenger rear seat has simply been made wider, forgetting that on the three-passenger body the occupant of this seat used the aisle for leg room, which is not possible for two people to do. The other

often it must do service all the year round. The all-year service has generally been bridged by having a demountable top fitted to the open body. This latter has many drawbacks as far as a neat appearance goes, but it has been the only real solution so far found to make one body applicable for summer and winter use.

The design of a close-coupled body, herewith illustrated, is one that is not too extreme, yet it has the advantages that are asked for in the newest designs of open bodies. It is low appearing and at the same time there is plenty of room above the seat cushions. These are the medium height above the floor with a drop of 3 in. from front to back and the seat backs are high enough for comfort and

have a good rake backward to insure a restful position. The lines graduate toward the front and rear, both on the side and top lines. On the side elevation the highest point is at the windshield base. The latter has an angle from the perpendicular of 17 degrees; the straight line of demarcation on the engine hood is carried to a finish at the shield. This body is today the most popular cowl, it adds to the length of the hood and gives a clean-cut termination to the round of the top of the hood without confusing it with the straighter lines of the body; the shield is set at the top of this and this is the starting point from which all lines graduate. The seats are set within the body top line, so that the latter is unbroken to the rear and below this top line is a parallel line formed by a narrow molding that tapers to a point at the front. The object of this double line is to give a lower appearance to the body side. The back of the body has a sloping end that serves as a locker. The extra tire is set perpendicular so that the door for access to same may be used without trouble.

#### **Body Offers Minimum Wind Resistance**

Looking at the car from above it will be noted that the lines here also graduate from a point opposite the front seat toward the front and rear, the shape of the stern end being defined by dotted lines under the top.

It can be appreciated by every car user that a body shaped as this design will offer the minimum of wind resistance. The tapered front presents the effect of a wedge and the same lines at the rear carry the air pressure to a gradual meeting from both sides, thus the eddies of air currents set up are diminished.

The door is of generous size and the ventilator in the cowl helps the circulation, also the windshield can be folded flat on the cowl when not required. The top is made with the rear curtain always enfolding the seat when up. This is called a gypsy curtain.

By the modern methods of manufacture by which the body panels are welded, this body does not present the difficulties in construction that it formerly did. The design shows a single panel from door around the back to the opposite door. This will be made in three and welded and is the most expensive part to make. The front is similar to the regular job and the shield is set on top. There are no moldings on the doors. The panel is doubled on itself and covers the opening and the effect when painted is that of an unbroken side line; the top line of the body side is flat, the side panel being carried over and fastened inside under the trimming finish.

The main dimensions in figures only are indicated. The scale at the bottom will give any additional sizes.

It is assumed that the reader understands that this body must be made with metal panels and aluminum is absolutely preferable for a special job. Sheet steel cannot be worked satisfactorily to make this shape without forms, and that is out of the question on one order.

For the color any of the prevailing dark colors are suitable. Not many are using bright shades this year, although the automobile shows had many bright colored cars. They do not seem to have become common in use.—Geo. J. Mercer, in *Automobile Trade Journal*.

John H. Leonhardt, president of the Leonhardt Wagon Mfg. Co., at Baltimore, passed away on August 17, at his home in that city. He was 69 years of age, and had been engaged in wagon making his entire business life.

## **Airplane Plants Will Buy**

Buying of considerable equipment for airplane plants is forecasted by inquiries which have been made in the New York market. The Inter-Continental Machinery Corp., 165 Broadway, New York, has issued a list totalling about \$1,000,000 worth of machine tools, and from the types of machines listed it is inferred that this is for an airplane engine plant. The Trego Motors Corp., New Haven, Conn., is inquiring for machine tools, and will issue a formal list soon. This concern plans building five twin-six engines per day. The Standard Aero Corp., Plainfield, N. J., has purchased the John Stephenson Co. car works of the J. G. Brill Co., and will convert it at once into an airplane factory, and through its engineers, Paine, McClellan & Campion, 25 Church street, New York, will purchase about \$300,000 worth of metal-working and wood-working machinery. The Simplex Automobile Co., New Brunswick, N. J., will close on its list of about 100 machine tools as soon as its contract with the government is formally signed. This concern will concentrate all of its facilities and activities on airplane engine work. The Packard Motor Car Co., Detroit, will do likewise on its \$16,000,000 worth of motor truck contracts, though it may take on some aviation motor work. The Pierce-Arrow Motor Car Co., Buffalo, is said to be willing to participate in airplane engine manufacture in addition to its motor truck work for the government. The Nordyke-Marmon Co., Indianapolis, has been buying additional equipment in Chicago for airplane engine manufacture. Orders have been placed also in Detroit and Cleveland by concerns engaged in making airplane motors or parts. Foreign demand continues active, France and Russia having closed recently for additional tools for airplane engines. The Aircraft Production Board is receiving bids for machine tools to be used on government airplane work.—*Iron Age*.

## **Consolidation of Carriage Concerns**

Carriage and wagon companies are rapidly becoming factors in the automobile industry. Among the latest mergers is that of the Olstyn Carriage Co. and the Central Wagon & Auto Co., of Cleveland, O. These concerns are to be known as the Truck Engineering Co., of Cleveland, and, as the name implies, will enter the commercial car field. The officers and directors include A. V. Cannon, E. M. Gregg, H. G. Hascall, W. C. Spaulding, J. Teteur, E. M. Whittenberger, C. B. Johnston and M. T. Gardner.

## **Rolls-Royce Erects Long Island Service Station**

The Rolls-Royce Co., Ltd., of London, has leased a 100 x 180 ft. plot in Long Island City, on the northeast corner of Harris avenue and Sunswick street from Frederick Ayer. A reinforced concrete, fireproof garage and service station is being erected, one story in height, with provision for additional floors.

## **Paige Leases More Space**

The Paige-Detroit Motor Car Co. has taken over under a ten-year lease the main building of the old William Bros.' plant, at Humboldt and Grand River, Detroit, which it will use for assembling purposes. The building is four stories high and of mill construction.

## Paint and Varnish

### Paint Shop Stock-Keeping

With paint shop supplies soaring aloft as perhaps never before it is of vital interest to the owner of a painting business to have the supplies used in his work handled most carefully and economically distributed. This can only be done when the work pertaining to this department of shop activity is turned over to a competent and experienced man authorized to control it with an eye single to promoting the highest possible efficiency and developing at the same time an economical use of the various supplies consumed. This is quite as important in the conduct of a small business employing three or four men as in the larger one. Indeed, in the shop employing only two men this same plan may be worked out better than when both have a hand in the preparation and caretaking of the material. One man power and authority in a matter of this kind will prove—in a great many shops is proving—of value in conserving and getting the largest returns from the materials carried in stock. It is important that some well suited corner of the shop, nicely lighted and located as far as possible from the dirt making parts, be set apart for the shelving and bench room which must be provided for the stock-keeping work. It is best in the arrangement of the shelving to provide for sliding doors, one to work in front of the others, for the protection from dust and dirt of the supplies. If possible, make this shelf room large enough to accommodate both the colors and the varnishes, thinners, japans, etc., which may be carried in tin or metal containers of gallon and half-gallon or fourth-gallon sizes. Beneath the bench room may very well be installed drawers for keeping sponges, wash leathers, sandpaper, putty knives, palette knives, scrapers, rubbing pads, and similar utensils having part and lot in doing the work of the shop. The motto may very well be "a place for everything and everything in its place." At the right hand of the shelf room and the mixing bench a brush wiping board, provided with 4 in. sides, top and bottom of same depth, and equipped with a hinged door, should be installed. This will insure a place for wiping out the brushes, and by keeping the door closed when the convenience is not in use it will also insure a clean wall space to look at. Having secured a good stock-keeping department, the next thing is to hold the man in charge responsible for the proper care taking and economical distribution of the materials and tools. This is a feature of shop organization indispensable to the business.

### Mixing and Matching Colors

The employe charged with the duty of stock keeping should be a good color mixer and matcher. This, as a matter of fact, should be esteemed a part, and a very vital part, of the stock keeper's duty. At all events, some one of the paint shop force had best be delegated for this important work, and if the stock keeper is qualified for the work so much the better. It is a class of work which cannot be performed by this, that and the other employe,

because any such order of things will mean an alarming waste of both labor and material. Generally, some employe will show a superior aptitude and skill for this line of work, and when this is proven clearly in comparison with what other employes are able to perform, the work in question should at once be turned over to the abler one. The fact that a very large majority of the pigments used in carriage and car painting come ready mixed does not alter the situation in respect to having some one capable of matching and mixing special colors almost daily in demand. The cars coming to the shop for touching up and varnishing almost without exception require touching up with a color matched to that of the old color field; this work, moreover, is an exceedingly difficult piece of work to perform. In practically all cases the color has faded more or less, in many cases to the extent of two or three shades, and when this has occurred it becomes an operation of extreme nicety to get the field color removed from the spots of the leopard. Only a colorist of signal skill and discrimination is able under such circumstances to produce a field color of real merit. Then there are cases coming along daily which need a fine ability in pigment preparation to keep correct color perspectives in view, while at the same time practicing economy in the use of pigments. Some workmen passing as expert color mixers and matchers waste an unpardonable quantity of stock in producing the results desired. Today this class of workmen are too expensive for employment in the work referred to. The really expert colorist is the one who at the expenditure of the minimum amount of labor and material is able to produce results of the highest order. Such a mechanic (or shall we call him an artist?) is indispensable in the business of painting vehicles, and his services need to be appreciated and rewarded accordingly.

### Proper Varnish Protection

To insure proper varnish protection it is necessary to afford the varnish the opportunity to fulfill its mission—to perform all the functions which the maker has designed it to perform. To attempt to make the varnish do for the surface what the pigments and the surfacing processes in general are provided to do, is to turn the uses of varnish into a channel for which they were never designed. In doing this the value of varnish, for which the painter pays his hard-won money, is subjected to a purpose unsuited to its capacity and therefore unprofitable to the consumer. Adequate varnish protection is established only when the surface is made up and brought out virile and strong, and substantial in body and in its capacity for holding forth the protective and illuminating varnish coats. The practice of giving minor attention to the primary surfacing coats and then forcing the varnish coats to make good the deficiency is fatal to the maximum durability, as it is alike fatal to the most efficient results and the largest economy. In all due measure the primary surfacing coats, made up of materials cheaper in quantitative measurements than varnish, should be made use of

to the largest possible extent. This will provide a surface rounded out and equipped with strength and fullness of life for the necessary and finest display of the varnish body with the least possible sacrifice of the depth and protective power of the latter. The most varnish left upon the surface at the finish, consistent with the quality of the finish, the greater durability and lustre will be the outcome. This result can only be established when the undercoat surfacing has been properly taken care of, with every coat made to do its share in fetching out the right body and depth of pigment. Then the varnish coats need have only that portion of surfacing which they normally need, and which leave them on the surface in their greatest fullness and their most radiant lustre. When it is necessary to produce the desired body and quality of surface and finish through the extreme rubbing and surfacing of the varnish coats it may always be taken to mean that the result has been accomplished at the expense of the protective capacity and the reflective power of the varnish. With this thought in mind is it not a matter of duty—of business sagacity, to put it on a broader basis—to give this question of varnish protection closer attention in order to develop better balanced surfaces and provide more and better protection for them?

### Getting Results With Rubbing Varnish

The first essential is to have the rubbing coats applied freely—flowed on rather than brushed on. The flowing coat of varnish is the coat, other things being equal, which brings out the fulness and body so much admired in the finish; it moreover provides through this same robust body the durability which car and vehicle owners in general are industriously seeking for. The brush coat more often than not brings brush marks into the body of varnish and these are hard—if not impossible—to remove. It means a lot of back-aching labor, and expensive labor, too, to fetch these brush marks down where they may not show badly, and it is seldom that the welts and roughness can be taken out entirely. The prevention consists in flowing the coats of varnish over the surface, thereby giving the varnish a chance to flow out fine and smooth and to shape up devoid of the roughness always a part of the coat brushed on. The tendency is, when brushing the coat of varnish on, to apply it so thinly that the material lays where the brush leaves it. There is not sufficient quantity to permit flowing out of the medium. Such a coat of varnish cannot be rubbed uniformly, and for this reason the surface must lack in smoothness and in levelness, the two supreme factors in the plan of finishing.

The color-varnish coats should be applied as freely as the clear rubbing coats, and these color-varnish mediums need to be all rubbed uniformly. Then when the clear rubbing coats come in order with the freedom of application which is a part of the flowing practice the actual work of rubbing with pulverized pumice stone and water resolves itself into a comparatively easy task. The main thing in the rubbing of such coats is to make them both level and smooth. The first coat of clear rubbing varnish will need simply to be worked down to the extent of beating off the gloss and shaving away the nibs of roughage. The second coat may well have the bulk of surfacing. This should partake of the nature of getting down to hard-pan—that is, rubbing close and firm and uniformly. With this fine, evenly rubbed surface, free from defects, the follow-

ing coat—and usually the last coat—will need but a minor rub with the water and pumice stone to fit it to hold out becomingly the finishing coat of varnish. In this manner the largest bulk and body of varnish is provided to make up the final finish, and to give the durability and depth of brilliancy, and the protection to the color coats, which goes as a part of the painting and varnishing practice.

### Drying Oven in the Small Paint Shop

While at the present time the drying or baking oven, as it is variously called, is not an actual necessity in the sense that the business cannot be successfully conducted without it, so far as the small shop at least is concerned, it is of such large value in the finishing of parts of the car, including fender irons, hoods, fenders, radiator shells, lamps, etc., that even the small shop owner may very well consider seriously the project of installing one. A small oven, gas heated, or if so located with reference to the supply, electrically heated, installed in the shop for the purpose of drying the finish on the parts above mentioned, will soon pay for itself, and then continue to turn money into the shop till. The electrically heated oven has the advantage, it is claimed, over the gas heated one in at least one important particular, viz., no fumes and gases are generated, and cleaner results ensue. With the drying oven the finish applied to the small parts of the car, and to some of the larger parts as well, may be hurried along without injury, and taken out of the way before the body and chassis finish is completed. And for such parts, at least, the baked-on finish becomes a very real part of the metal, with a lustre that wears on and on. The vibration and strains imposed upon the metal parts that are usually detachable from the body and chassis of the car make it highly important that, so far as possible, these parts may be finished with materials devoid of artificial driers and gums in order that they may be sufficiently elastic to freely respond to the strain put upon them. Through the use of the drying oven, these mediums employed for hastening the drying of the materials may be eliminated, and all required elasticity provided for. Baking the coats does the rest. The linear expansion of steel surfaces has been found to be more than twice that of wood, a fact that seems to directly justify the use of more elastic coatings.

Many experts are now agreed that a rather prolonged baking period at a lower temperature than has been used formerly will prolong the wear of the finish, render it more impervious to moisture, and give it greater elasticity. The position is taken by many of these experts that a coat of material, paint or varnish, baked for 12 hours at a temperature of 180 deg., will give better results than if baked for five hours at 280 deg. Many of these men claim that the resistance of paint and varnish baked on, to moisture, gases, and atmospheric impurities in general, is in the ratio of 2 to 1 compared to the unbaked finish. The disadvantage so far to be noted in connection with the employment of the baking oven is that in many cases there is an inclination to quickly bake the coats at a high degree of temperature. We have personally known of some shops which during the past year or two have installed baking ovens and have adhered to the practice of applying the painting and finishing coats complete, in three days. For a first class finish this degree of celerity is quite too extreme, and it is to be condemned outright.

Of course, it is to be understood that some colors require a higher degree of heat to bake properly than do many



others, but in all cases the needs of the individual pigment should be taken into account. White, for example, should never be baked at a degree exceeding 100, and it were better to use 85 deg. F. A degree about 100 is likely to yield a yellowish or ivory white surface, which is ruinous to a finish put out for blank white. Black, the opposite of white, may safely be baked for six hours at a degree anywhere between 150 and 200. Primers and surfacers are baked at degrees varying from 160 to 200 for three hours or more. Finishing varnishes may be baked at degrees from 110 to 150 for five or six hours. If the paint shop owner is located in a shop of sufficient size and capacity to warrant the operation of an oven large enough to take in a car entire, and the extent of his business will justify the outlay, then we should grant it a good paying proposition. The day of the oven drying method for painting and finishing the motor car is here for all establishments having adequate facilities for housing and operating the oven, or a battery of them, for that matter. And for the small shop, with its smaller circle of patrons, the oven of minor size, capable of taking care of the small parts of the car, the arrangement will be found most convenient and profitable. A friend of the writer's not being able to install the oven baking method has adopted the plan for prompt drying of the varnish coats of heating the shop to as high a degree as safety first law will permit, and in this degree of warmth, uniformly maintained, for the first 12 hours following the application of the varnish coat, the drying is greatly accelerated, and especially in emergency cases the practice has been found of no small value. This is not a newly discovered practice, but rather an old one reapplied to present day needs, and in this case it is working out splendidly.

### General Theory of Wind Resistance

So much has been said about the stream line body, and the way in which automobile designers endeavor to cut down wind resistance that it may be of interest to shed a little light on the subject and to tell what wind resistance really means. We are used to hearing such expressions as "cutting through the air," and other phrases of a similar nature, but many people interested in the subject from the automobile standpoint would like to know just how much pressure really exists and just how much power is absorbed in overcoming the resistance of the air.

We all know that this fluid we call air and which forms the atmosphere of the earth rests upon the surface of the earth and surrounds it for a considerable distance. It seems to be an intangible substance which does not oppose us in the least as we walk about, but as soon as we begin to move at speeds much higher than we were intended to move by nature, it exerts its influence to a marked extent.

At other times, when we ourselves are stationary, the air will move, causing what we call a wind and exerting a pressure in much the same way. Tall buildings have to be designed to resist this wind and also to minimize its effects. The pressure of the wind is utilized as power in windmills and in sailing vessels.

Wind, in other words, is the relative motion of a body to the air surrounding it, and this relation is quite similar whether the air is still and the body moving, the body moving and the air still, or both. The relative velocity of the wind is the sum of the velocities of the object and the wind if they are moving in opposite directions, or the

difference if they are moving in the same direction. For instance, if the velocity of the wind is 30 miles per hour and a car is going 30 miles per hour into the wind in the opposite direction, the relative velocity of the wind to the car is 60 miles per hour. On the other hand, if the car were traveling with the wind at 30 miles per hour the relative velocity of the wind would be zero. The pressure exerted by the wind on a moving body is governed by its relative velocity to that body.

The average man, walking briskly, travels at about four miles per hour. His body presents to the air a surface of about six feet in height to one foot in width, or about six square feet. Moving at four miles an hour, he is traveling at 5.8 feet per second, and the resistance opposed to his forward motion by the air, assuming it to be still, is just about one-half pound. In other words, he is continually pushing a one-half pound resistance ahead of him as he walks.

If the same man walking four miles an hour was facing a gale blowing 26 miles an hour, the relative velocity of

### Wind Resistance at Different Speeds

Miles per Hour	Feet per Second	Pressure per Sq. Ft. in pounds
1	1.47	0.005
2	2.93	0.020
3	4.4	0.044
4	5.87	0.079
5	7.33	0.123
6	8.8	0.177
7	10.25	0.241
8	11.75	0.315
9	13.2	0.400
10	14.67	0.492
12	17.6	0.708
14	20.5	0.964
15	22.00	1.107
16	23.45	1.25
18	26.4	1.55
20	29.34	1.968
25	36.67	3.075
30	44.01	4.429
35	51.34	6.027
40	58.68	7.873
45	66.01	9.963
50	73.35	12.30
55	80.7	14.9
60	88.02	17.71
66	95.4	20.85
70	102.5	24.1
75	110.	27.7
80	117.36	31.49
100	146.67	49.2

the wind would be 30 miles per hour and the man would be walking against a pressure of over 26 pounds. This would be enough to make an appreciable difference in the ease of walking and he would readily notice it.

The resistance that the air interposes to the progress of the car is of two kinds. There is first the resistance that is caused by striking the banks of air that is always in front of the car, in other words, the wind resistance, and there is also the resistance that is caused by the friction of the air along the car. This second resistance is what is known as skin resistance. It is so small in relation to the wind resistance that it can be passed by unnoticed.

### Resistance to Automobile

The ordinary type of passenger car or truck presents a flat surface to the wind. In other words, there are no

"entrance lines" like there are in a boat for the purpose of opening an easy path into the fluid. Thus the wind resistance can be calculated directly from the total area of the plane surface which form the front surfaces of the car.

This entering area is composed of the radiator, lamps, projected surface of the fenders, windshield, front axle, front edges of the wheels and whatever else may be on the entrance side of the car. On the ordinary type of touring car this area is about 14 sq. ft. The accompanying tabulation shows the resistance per square foot at different car speeds and with the table it is quite easy to know the number of pounds that the car has to overcome in traveling at different speeds.

For instance, at 10 miles per hour, assuming that the 14 sq. ft. is correct, and noting from the table that the resistance is .492 lbs. per sq. ft., or approximately  $\frac{1}{2}$  lb., the resistance to the car would be seven pounds.

At 20 miles per hour the resistance per pound is 1.968, or close to 2 lbs. per sq. ft., and the resistance for the car would be 28 lbs., so that at double the speed the resistance has become four times as great. At 30 miles per hour the resistance per square foot, as shown by the table, is about  $4\frac{1}{2}$  lbs. per sq. ft. and the resistance to the car has risen to 71 lbs.

#### Wind Absorbs 40 Horsepower

At 60 miles an hour, or a mile a minute, which is the highest speed the average touring car is capable of reaching, the resistance is 17.71 lbs. per sq. ft., or for the car with 14 sq. ft. front area, the resistance has risen to over 250 lbs. continuous pressure. At the end of a mile, or 5,280 ft., the car has done  $250 \times 5,280$ , or 1,320,000 foot-pounds of work in one minute. As a horsepower is only 33,000 foot pounds of work in a minute, the horsepower required to overcome the resistance of the car alone amounts to  $1,320,000/33,000$ , or 40! In other words, it takes a 40 horsepower engine to overcome the wind resistance alone at 60 miles an hour!

There is no wonder that when we have racing cars traveling at 100 miles an hour, care is taken not to enter the wind with a flat surface. Instead of banking the air with a flat surface, which can readily be done at 25 or 30 miles an hour, the air is cut by a wedge in the racing car. If it were not, the flat surface would have to overcome a resistance of 50 lbs. per sq. ft.

It is in the racing car that the value of the stream line enters. Air which is split apart must close together again, in the same way that water does. As it closes up, if it presses upon the properly shaped body, or an inverted wedge, it tends to force that body ahead, hence the long tails on racing cars. The tails is thus just as important as the front end. The skin resistance at the high speeds becomes important also, and for that reason the surfaces are kept as smooth as possible.—Merle Shepard, in New York American.

#### Society of Automotive Engineers and the War

Much has been printed, from time to time, regarding the important functions performed by engineers in the conduct of modern warfare. Perhaps no fields of engineering are more important than those represented in the Society of Automotive Engineers, and this society has been and is performing splendid service for the Federal government.

For more than a year the society, through its truck standards division and many of its engineering members, has been co-operating with the Quartermaster department in the formulation of specifications and designs for military trucks. No less than 50 S. A. E. members are now located in Washington, giving active assistance and advice to the government in the design of the military trucks.

In connection with the aircraft program, the society is co-operating in an equally effective manner. The chairman of the aircraft production board is a past president of the society, and two of its four other civilian members are also prominent members.

The chief of the aircraft engineering division of the signal corps, the late lamented Henry Souther, was also a past president of the society, and in each of the subdivisions of this section, the society is represented by at least one member. The sections included are airplane, inspection, power plant, transport, design and experimentation. In co-operation with the aircraft engineering division of the signal corps, and with the aircraft production board are a very large number of S. A. E. members, some holding positions of authority, and others in a subordinate capacity.

Outside the organization of the government, but in very close co-operation with it, the aeronautic division of the Society of Automotive Engineers' standards committee is doing excellent work.

The standard U. S. A. aviation engine has been designed by two well known engineers, both of whom are prominent members of the society; while associated with them in this work are several other members.

In the Ordnance department the need for motorization of artillery, and the handling of ammunition by means of motor-driven vehicles are fully appreciated. In the development of apparatus for this purpose, the society is represented by its president, a past vice-president and several other members of the society. Rapid strides are being made toward what will doubtless be the most completely motorized artillery equipment of any of the allied powers. This motorization involves not only the use of numerous trucks, most of which will be of the four-wheel-drive type, but also the use of numerous tractors. Closely associated with this work are the design and construction of any apparatus like so-called tanks, that may be developed. Another past president of the society is commissioned to work upon the development of these special engines of war.

But the activities of an engineering organization are not by any means confined to the destruction side of warfare. Engineers must, for example, be charged with the design, operation and upkeep of motor-driven ambulance equipment. Another member of the society has recently been commissioned to take charge of this important work.

It is obvious that the Society of Automotive Engineers is living up to its reputation for efficient co-operation, and that there is very good ground for its maintaining a branch office in Washington. This Washington office is not only forwarding the co-operation with the government outlined above, but is keeping in close touch with the various branches of the War and Navy departments, with the purpose of helping these departments secure the assistance of capable men for the conduct of engineering work. In so doing, it is also serving its membership, by helping to secure commissions for those of its members who are desirous and well qualified to enter the government service.

# Vehicle Industry News in Brief

## Truck Builders

**Sullivan Motor Truck Co.**, Rochester, N. Y., has increased its capital from \$40,000 to \$80,000.

**Cadillac (Mich.) Auto Truck Co.** has awarded a contract for a new assembling building to cost \$35,000.

**Lapeer Truck Co.**, New Haven, Mich., has purchased eight acres of land and will erect a new modern factory.

**Hahn Motor Truck & Wagon Co.**, Hamburg, Pa., is building a new one-story extension, about 64 x 120 ft., to be used as an assembling plant. The structure will cost \$10,000.

**Conestoga Motor Truck Co.**, Lancaster, Pa., will build its first plant, 60 x 200, to be ready for operation October 15. Meantime Conestoga trucks will be assembled in temporary shops.

**Trailer Truck Co.** has been organized at Nashotah, Wis., to manufacture a new type of adjustable trailer for carrying long timbers or poles. L. E. Utter and Ralph Howland are the organizers.

**West Motor Co., Inc.**, New York, has been incorporated with a capital of \$25,000 to manufacture commercial automobiles. The incorporators are A. M. Sullivan and S. S. and H. Myers, 318 West 100th street.

**La France Motor Truck Co.**, Elmira, N. Y., has been incorporated with a nominal capital of \$5,000 to manufacture motor trucks. H. C. Mandeville, A. La France and I. L. Booth, all of Elmira, are the incorporators.

**Lyndall Motor Truck Co.**, Philadelphia, has been incorporated in Delaware with a capital of \$10,000 to manufacture motor trucks, etc. Frank S. and Arthur C. Lyndall, both of Philadelphia, are the principal incorporators.

**Oneida Motor Truck Co.**, Green Bay, Wis., will erect a factory 300 x 150 ft., on a tract of land comprising 47 acres, just acquired. The new plant is needed to handle government contracts. Additional stock is being issued for the development of the business.

**Ton-A-Ford Trux Co.** has been organized at Racine, Wis., with a capital stock of \$200,000. The incorporators are Herman R. Swanke, Geo. Beardsley, Louis Boldig and Fred Boldig. The company will produce a truck unit for the Ford chassis.

**United States Motor Truck Co.**, Cincinnati, is preparing shortly to install progressive assembly lines at its factory. The company will be one of the first to adopt progressive assembly for heavy duty trucks. One of the buildings, 500 x 98 ft. and two stories in height, will be used for this purpose.

**Turnbull Motor Truck and Wagon Co.** is a new company headed by W. O. Allen, of Fostoria, O., to take over the Turnbull Wagon Co., of Defiance, O. A campaign to raise a million dollars was successfully carried out by the Defiance Chamber of Commerce. The new company is to have an annual capacity of 5,000 to 10,000 motor trucks.

**Armstrong Whetstone Co.**, Lapeer, Mich., is producing the Minute Truck, a trailer used to convert a passenger car into a truck rapidly. The trailer sells for \$48 and has a capacity of 1,000 lbs. and a body 42 x 72 x 10 in. The company is also manufacturing a delivery body for Fords with a capacity of 500 lbs. The cost is \$15. The body is 52 in. long and 34 in. wide, with 10 in. sides and 6 in. flare-boards.

**Landover Truck Co.**, Chicago, has decided to move its works and office to Marinette, Wis., where local capital has subscribed to a fund of \$25,000 to be used for the purchase of machinery, materials and labor. The company will occupy the former plant of the Main Street Iron Works, which is now being overhauled and reequipped. Production will begin in September. E. W. LeRoy is chairman of the Marinette committee.

**Wisconsin Duplex Auto Co.**, Clintonville, Wis., organized recently, with capital stock of \$500,000, to manufacture a quadruple drive chassis for passenger cars and trucks, is completing the first models in a Milwaukee machine shop under the direction of William A. Besserlich, president and general manager, who designed the transmission system. Erection of the first unit of a new plant at Clintonville will be begun shortly. Mr. Besserlich was one of the original designers of the Four-Wheel-Drive truck, and with W. S. Zachow organized the Four-Wheel-Drive Auto Co., Clintonville, Wis., now capitalized at \$1,000,000. He withdrew recently to engage on his own account in the manufacture of a new design.

## Body Builders

**The Highland Body Mfg. Co.**, Cincinnati, is extremely busy, working two shifts.

**O. J. Beaudette Co.**, Pontiac, Mich., has begun work on a new plant to cost \$35,000.

**Detroit Auto Products Co.** has added the manufacture of a special Ford sedan body.

**Auto Body Co.**, Appleton, Wis., has increased its capital stock from \$5,000 to \$25,000.

**Auto Body Co.**, Lansing, Mich., is floating \$250,000 of treasury stock to provide for extensions.

**Fisher Body Co.**, Detroit, has had plans prepared for a new one-story plant, about 90 x 550 ft., to be erected on West End avenue for its aeroplane department.

**Loomis Wheel and Body Works Co.** has been organized at Dallas, Tex.; capital stock, \$7,500. Incorporators: A. M. Loomis, E. M. Powell and Walter G. Miller.

**E. J. Jaquith**, who built carriages and wagons for years at 360 South Alameda street, Los Angeles, Cal., is now going more extensively into the business of building auto bodies.

**Universal Truck Body Co.**, Jonesville, Mich., is erecting a new factory and enlarging its force of workmen prepa-

ratory to turning out large orders which have been received.

**Macdonald Mfg. Co.**, Wellesley, Mass., has been organized to manufacture all kinds of vehicle bodies and tops. Capital \$50,000. Incorporators: John A. Singler, John V. Macdonald, Fred Platts.

**Weigel-Warnsmann Wagon and Auto Body Co.**, Cleveland, capital \$20,000, has been incorporated by Henry Weigel, Kathrine Weigel, Henry Warnsmann, Augusta Warnsmann and Sara C. Guest.

Leonard Coates, St. Louis, formerly sales and advertising manager of the Banner Buggy Co., has accepted a similar position with the Barnett Sales Co., of that city, manufacturer of commercial bodies for light cars.

R. W. Allen has been elected vice-president of the C. R. Wiison Body Co., Detroit, and will have charge of manufacturing. He has been purchasing agent for six years, and hence is familiar with the manufacturing end of the business, with which he always has been in close touch.

**All Season Top Co.** has been formed in Marshall, Mich., and has taken over the material stocks of the All Season Body Co., which is to receive a royalty on goods manufactured by the new top company, which has leased the plant of the Page Bros. Buggy Co. John A. McAvoy, who was connected with the American Top Co., of Jackson, is at the head of the new enterprise.

**American Auto Body Co.**, North Milwaukee, Wis., recently incorporated to manufacture commercial bodies will erect additional buildings and increase its working employ 400 men. The factory is fully equipped with the latest machinery and will be open for business within a few weeks. Joseph Tysfenhart, who has been connected with leading concerns in the east, has been secured as manager.

### Car Builders

**Locomobile Co.**, Bridgeport, Conn., will build a new factory, 32 x 315 ft., one story.

**Motor Vehicle Co.**, Lafayette, Ind., has increased its capital stock from \$25,000 to \$75,000.

**White Co.**, Cleveland, is building a \$300,000 addition to its factory which will be 125 x 500 ft., of concrete and steel and two stories high.

**General Motors Corp.** is arranging for the vacation of portions of property in Flint, Mich., on which it will erect new factory buildings.

**Grant Motor Co.**, Cleveland, has awarded a contract for the erection of its plant extension. This will be a two-story building, 60 x 260 ft.

**Lexington Motor Car Co.**, Connersville, Ind., will consider plans for the construction of a second addition to the plant to be completed this year.

**Friddle Motor Car Co.**, Cleveland, has been organized to bring out a new line of automobiles, and has purchased a small amount of machinery for development work.

**The Sayers & Scovill Co.** purchased the Frank Enger plant at Cincinnati and are making some decided improvements. They will manufacture a very fine passenger car, the "Sayers Six," and have now a number of orders on hand.

**Monitor Motor Car Co.**, Columbus, O., has purchased a site on Third avenue on which it intends erecting a building with 100,000 sq. ft. of floor surface. The present plant is on Mount Vernon avenue.

**Scripps-Booth Corp.**, 2 West 57th street, New York, manufacturer of automobiles, has called a special meeting to increase the capital from 70,000 to 120,000 shares, with active operating capital of \$600,000.

**General Motors Co.**, Detroit, Mich., has completed plans for the construction of a new drop forge plant to cost about \$300,000. The addition will consist of three one-story structures, 160 x 600 ft., 75 x 600 ft. and 65 x 300 ft.

**Studebaker Corp.**, South Bend, Ind., has awarded a contract for the construction of a power plant 123 x 87 ft. The plant will be of steel and brick construction, and two immense smoke stacks will be constructed. The building will cost about \$100,000.

**Comet Automobile Co.**, Decatur, Ill., will build shortly the first unit of the factory designed to construct automobiles. It is hoped to have the first structure completed before cold weather. This will be a one-story structure, 150 x 600 ft. It will be utilized for assembling parts, building bodies and painting and trimming.

### Parts Makers

**Edward F. Lyon Co.**, Detroit, has been equipped to manufacture axle shafts for automobiles.

**Wyman & Gordon Co.**, Worcester, Mass., has awarded a contract for an addition to a forge shop, 40 x 100 ft., one story.

**Zenith Carbureter Co.**, Detroit, Mich., is building a new four-story addition, which will increase its output 80 per cent.

**General Auto Parts Corp.**, 328 Adams street, Newark, N. J., has filed plans for the erection of a new one-story molding shop.

**Auto Radiator Co.**, 1315-17 Vine street, Philadelphia, is taking bids for the construction of a new two-story plant, about 30 x 80 ft.

**Hess-Pontiac Spring and Axle Co.**, Pontiac, Mich., will receive bids early in the fall for the construction of two additional factory units.

**Oakes Mfg. Co.**, Indianapolis, manufacturer of automobile parts and metal stampings, has increased its capital stock from \$35,000 to \$250,000.

**Simmons Machine Co.**, 985 Broadway, Albany, N. Y., is planning for the construction of a new one-story addition to its plant to cost about \$12,000.

**National Spring & Wire Co.**, Albion, Mich., has sold its Windsor plant to the McGregor-Banwell Co., of Ford City, Ont., manufacturer of wire fences.

**Parker Rust-Proof Co. of America**, Detroit, of which Clark W. Parker is president, will establish a factory for the manufacture of its product in St. Louis.

**Jenkins Vulcan Spring Co.**, St. Louis, will locate a factory at Richmond, Ind. It will employ 75 men and will have a capital of \$300,000. It will purchase an eight-acre tract and construct its building.

**Modine Mfg. Co.**, Racine, Wis., organized in January, 1917, to manufacture automobile, truck and tractor radia-

tors and cooling systems, is enlarging its capacity to 3,000 radiators a month. A. B. Modine is president.

**P. T. Wheel Co.** has been incorporated at Dayton, O., with a capital of \$50,000 to manufacture automobile wheels. Incorporators: G. H. Gorman, E. J. B. Gorman, A. M. Leoni, A. B. B. Gorman and O. B. Brown.

**Detroit Auto Radiator Co.**, 182 Fifth street, Milwaukee, has incorporated its business, established two years ago, under the laws of Wisconsin without change of name. The capital stock is \$10,000. Joseph Colker is president.

**Lycoming Foundry & Machine Co.**, Williamsport, Pa. will erect additional buildings and increase its working force to handle a large order from the Dort Automobile Co. The contract will keep the mills working for three years.

**Century-Plainfield Tire Co.**, Plainfield, N. J., has been incorporated with a capital of \$10,000 to manufacture automobile tires and kindred specialties. Charles P. L. Huston, 902 North avenue; William F. Hart and James D. Grant, all of Plainfield, are the incorporators.

**Wisconsin Gear & Axle Co.**, Milwaukee, has been incorporated with a capital stock of \$100,000, to engage in the manufacture of gears, transmissions, axles and other automobile, truck and tractor parts. The incorporators are Herman W. Noll, 1057 Muskego avenue; Jacob Scharmer and Bernard A. Hoermann, all of Milwaukee. Plans will be announced later.

**Torbensen Axle Co.**, Cleveland, O., due to increased activity in the demand for the company's 3½ and 5 ton axles, will build an addition to its plant. The new two-story building will be devoted exclusively to these two types, giving more than 30,000 additional feet of floor space. A new heat treating plant is also now being installed, and a power plant capable of generating 600 horsepower.

### Miscellaneous

**Miami Trailer Co.**, Troy, O., has commenced work on a two-story addition, 60 x 65 ft., of mill construction.

**Automatic Control Trailer Co.**, Columbus, O., intends to add to its equipment for the manufacture of automobile and auto-truck trailers.

### Seventy-five Million Tons Ore Mined in 1916

The iron ore mined in the United States in 1916 reached a total of 75,167,672 gross tons, the greatest annual output ever made. The shipments from the mines in 1916 were 77,870,553 gross tons, valued at \$181,902,277. The quantity mined in 1916 was more than 19,600,000 tons greater than mined in 1915. The increases in quantity and in value of iron ore shipped in 1916 amounted to 40 and 80 per cent, respectively. The average value per ton at the mines in 1916 was \$2.34, as against \$1.83 in 1915. These figures, which were compiled under the direction of E. F. Burchard, of the United States Geological Survey, Department of the Interior, include for 1916 only iron ore containing less than 5 per cent of manganese.

Iron ore was mined in 24 states in 1916 and 23 in 1915. Two of these states, Nevada and Utah, produced iron ore for metallurgic flux only; part of the output of Colorado and New Mexico was used for smelter flux and part for

pig iron and ferro-alloys; Michigan and Minnesota report the production of some ore used in open hearth furnaces to "reduce carbon," and North Carolina reports the production of magnetite ore used in a puddling furnace at Knoxville, Tenn.; the remaining states produced iron ore for use in blast furnace only, except small quantities used for paint from Michigan, New York and Wisconsin. Minnesota, Michigan and Alabama, which have for many years produced the largest quantities of iron ore, occupied in 1916 their accustomed places.

### Simmons' Universal Grinding Machine

We are making reference to the Standard No. 6 machine of which we present an illustration.

This is the day of strong demand and tardy supply of about all machine tools, so it is well to study what will best fit requirements before ordering.

We find that the Simmons Machine Co., Inc., with offices in the Singer Building in New York City, has put out a very sturdy machine with a real wear-resisting design. This fills the bill when machinery is crowded over the limit as is often now the fact.

A grinding machine must have plenty of iron in the table, and same is true of head and tail stock. The Sim-

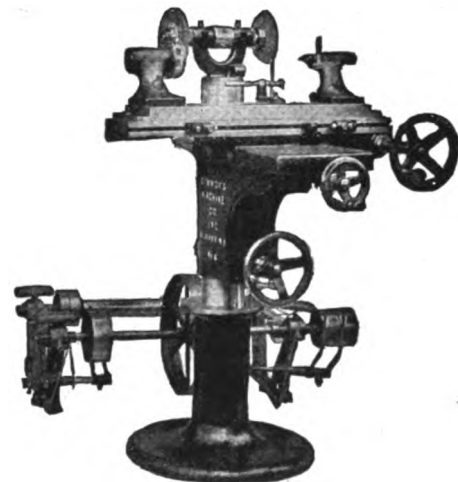

mons more than fulfills the specifications. The head stock is fitted up with a large bearing for the chuck spindle, also special navy specification bronze bearings. The spindle is tapered and tapered, bored to take wheel arbors with very substantial bearings, 1 in. diameter by 2¾ in. long. Bearings are self-lubricating.

These are just a few of the features that an expert buyer looks for, but you can't give in words the effect a well-designed machine has in the eye of an experienced buyer or user. Pictures are just an approximation, but investigation is knowledge at the source. What we say is just a stimulus. In this instance we picture and sketchily describe a money's-worth machine. Look it over.

### Chicago Show Dates

Dates for the Chicago show have been set for the week of January 26 to February 2, 1918. As in previous years, the second of the big national displays will follow the New York show after an interval of two weeks. Delay in making the announcement was due to some question of the possibility of securing the First Regiment Armory in Chicago, in addition to the Coliseum.

**St. Louis Vehicle Builders' Picnic**

The thirteenth annual basket picnic of the Carriage, Wagon and Auto Builders' Club, of St. Louis, took place at Wallner's Grove, St. Louis, on Wednesday, August 22. The picnic brought together the vehicle builders and representatives of the accessory trades, who, with their families and friends, enjoyed a very fine day's outing. Frank Kranz was chairman of the committee on arrangements, which was composed of the following gentlemen: Messrs. Frank Kranz, Louis Moller, H. E. Spaete, F. M. Roehlk, D. J. Keck, F. Heimbürger, C. Pamfel, E. Beindieck, Hy. Uhlenhaut, Ed. Johanning, Geo. Brandt, Chas. Sonnemann.

**Federation Convention Dates**

The eighteenth annual convention of the National Federation of Implement and Vehicle Dealers' Associations will be held in Chicago, Oct. 9, 10, and 11, 1917. The Hotel Sherman will be the headquarters. The convention of the secretaries' association will be held Oct. 8 at the same place. A conference will be held with the committee on dealers' associations, and the sales managers' department of the National Implement and Vehicle Association. A few more delegates than usual are expected to attend this convention.

**Welds Without Hammering**

A welding compound which will weld without the use of a hammer is manufactured by N. D. Doxey, Elmira, N. Y., under the brand of "Anchor Welding Compound." Place two flat pieces together in the fire, smelting the compound liberally on the parts and press them together firmly with tongs and the weld will be complete. It will weld the hardest steel and will not pull apart at the weld, thus losing the heat, nor burn up when flowing on the lap. The welded parts are of equal strength with the solid parts of the metal and cannot be damaged by dampness or heat.

**WANTS**

Help and situation wanted advertisements, 1 cent a word; all other advertisements in this department, 5 cents a word; initials and figures count as words. Minimum price, 30 cents for each advertisement.

**Wanted**—Copies of The Hub of May and July, 1916. Must be in good condition. Address Trade News Publishing Co., corner Elm and Duane streets, N. Y. City.

**PATENTS**

**Patents**—H. W. T. Jenner, patent attorney and mechanical expert, 606 F St., Washington, D. C. Established 1883. I make a free examination and report if a patent can be had and exactly what it will cost. Send for circular.

**FOR SALE**

**For Sale**—"Motor Body Work for Commercial Cars," a new text book dealing with the construction of all types of bodies for business purposes. Contains also six working drawings and a glossary of technical terms, together with diagrams and sketches. Price, \$1.20 net; by post, \$1.56. Orders should be accompanied by remittance. Cooper's Vehicle Journal, Ltd., 19 Garrick street, Long Acre, London, England.

**SITUATIONS WANTED**

Carriage painter wishes a job in country town, to take charge; all round man. W. A. Riggleman, Jamestown, O.

**Index To Advertisers**

American Motors Corporation.....	4
Barrell Co., Wm. L.....	42
Bliss, E. W., Co.....	3
Bookwalter Wheel Co.....	44
Bradley, C. C., & Son.....	45
Brennan Motor Mfg. Co.....	47
Bridgeport Coach Lace Co.....	11
Century-Plainfield Tire Co.....	10
Century Steel Co. of America, The.....	43
Columbus Bolt Works.....	Back cover
Cowles, C., & Co.....	44
Crane & MacMahon, Inc.....	Back cover
Decker, J. C.....	44
Dixon, Joseph, Crucible Co.....	9
Dowler, Chas. L.....	44
Doxey, N. D.....	40
DuPont Fabrikoid Co.....	42
Eccles, Richard, Co.....	46
Empire Art Metal Co., Inc., The.....	8
G & O Mfg. Co.....	47
Gray, Peter, & Sons, Inc.....	45
Hartford Auto Parts Co.....	3
Hoopes Bro. & Darlington.....	47
Hotel Brunswick.....	45
Hotel Tuller.....	40
Johnston, R. F., Paint Co.....	44
Keratol Co., The.....	42
Laidlaw Co., The.....	2
Lumen Bearing Co.....	41
Millersburg Fifth Wheel Co.....	44
Mulholland Co., The.....	44
Murcott-Duden Co., The.....	2
Norton Grinding Co.....	5
Parrott Varnish Co., The.....	2
Pettingell Machine Co.....	7
Pittsfield Spark Coil Co.....	41
Porter, H. K.....	45
Poughkeepsie Utilities Corp.....	40
Pressed Steel Co.....	2
Quickwork Co., The.....	45
Rome-Turney Radiator Co.....	46
Russell, Burdsall & Ward Bolt & Nut Co.....	45
Sheldon Axle & Spring Co.....	Front cover and 39
Simmons Machine Co., Inc.....	40
Standard Oil Cloth Co., Inc.....	6
West Tire Setter Co.....	47
White-Quehl Mfg. Co.....	44
Wilcox Mfg. Co., D.....	47
Wiley Co., C. A.....	46
Williams, J. H., & Co.....	12
Wing, Chas., Co.....	44
Yoder Company, The.....	Back cover



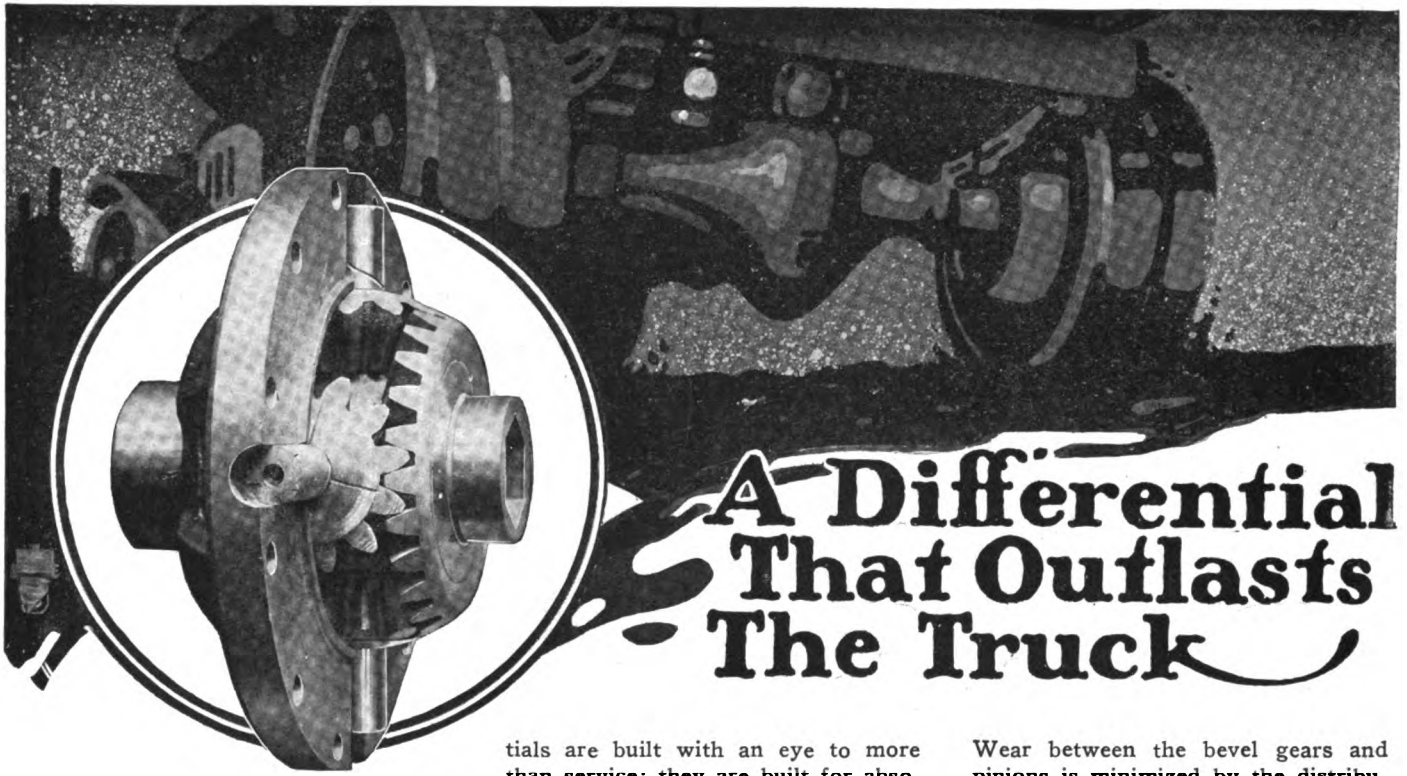

# A Differential That Outlasts The Truck

The Sheldon Worm Gear Rear Axle owes its demonstrated superiority over all other truck rear axles to the fact that every part of it has been as highly developed mechanically as the best modern engineers could make it.

**THE PERFECTED DIFFERENTIAL DESIGN** is an important factor in this engineering achievement.

Sheldon Differentials are built in a way that makes them the most durable and trouble-proof parts of Sheldon-equipped trucks.

With scrupulous care our engineers have eliminated every weakness that has shown itself in ordinary type differentials.

In the first place, Sheldon Differen-

tials are built with an eye to more than service; they are built for absolute security in service. There is no skimping of room and materials.

The construction of the bevel gears with an extended hub inserted into a bearing ring in the spider is a big factor in making Sheldon Differentials trouble-free. It gives the gear bearing on both sides and unites the whole differential into a more inflexible unit, insuring absolute alignment of moving parts.

By the use of a hexagonal instead of the usual square or splined insertions for the axle shaft, greater strength of metal to take strains is secured in the bevel gears.

Oil holes and grooves give unusually ample provision for the lubrication of all moving parts.

Wear between the bevel gears and pinions is minimized by the distribution of the load over larger contact surfaces, preventing oil being squeezed out from between the teeth by undue pressure.

In fact, Sheldon Differentials are so made that you insure yourself against differential trouble when you buy a truck equipped with a Sheldon Worm Gear Rear Axle.

It will pay you always to look for the double anchor on the rear axle before buying a truck.

**SHELDON AXLE & SPRING COMPANY**

*Makers of Springs and Axles for Heavy Duty Service for Over Fifty Years*

Wilkes-Barre.

Penna.



*Note the oil grooves and holes that insure thorough lubrication of all moving parts of Sheldon Differentials.*



*Note the bearing hub on the inner face of the bevel gear that fits into the ring in the spider.*

Please mention "The Hub" when you write.



# ANCHOR WELDING COMPOUND

MANUFACTURED BY  
**N. D. DOXEY, ELMIRA, N. Y.**

ANCHOR WELDING COMPOUND will weld hardest steel. Will not peel apart at the weld, thus losing the heat, nor burn up when flowing on the lap. Will weld without the use of hammer. Place two flat surfaces together in the fire, smelting the Compound liberally on the parts and press pieces together firmly with tongs, and weld will be complete without a stroke of the hammer. It will not require any iron filings to be added in welding as in some other compounds. It does the work itself. A weld made with ANCHOR COMPOUND leaves the welded parts of equal strength with solid parts of the metal. Cannot be damaged by dampness nor by heat.

Your Welding Compound gives entire satisfaction. In welding steel of high carbon, it fluxes quick and the steel appears like iron, and can be worked at a white heat. I have tried all other compounds in the market and can pronounce yours the best. It flows where you want it to flow.

C. H. KILMER, Elmira, N. Y.

We take pleasure in stating that we have been using your Welding Compound for several years and find it a most excellent article, and can recommend it highly. Yours truly,  
THE LAFRANCE FIRE ENGINE CO.,  
W. Falck, Gen. Manager, Elmira, N. Y.

Is used by U. S. Navy and C. & N. W. Ry. Co. and many others.

IN USING do not throw the Compound from the surface to be welded, but cup the scarf, and in light work turn the piece, when ready for welding, so that the Compound will flow evenly over the surface to be welded, which it will readily do, flowing like oil. In heavier work, add compound to surface to be welded, as heat nears welding point, so that surface to be welded is covered with fused compound.

**DO YOU HEAR** GO AHEAD  
the UTILITY KID signaling  
you to go ahead and get  
**UTILITY VARNISH RENOVATOR**

## Utility Varnish Renovator

*"The ONE that WILL"*

Give satisfaction to ALL.

Keeps that auto looking "spick and span" at a minimum of time, labor and expense and with perfect SAFETY to the fine varnish finish. And that's just why we called it "Utility"—that whole car washing job is minimized to a piece of cheese cloth and a bottle or can of "Utility." Or, if desired, we furnish sprayer.

DEALERS: This is a NECESSITY not a luxury. The great demand has enabled us to offer you "Utility Varnish Renovator" at a figure that we don't think you can duplicate—at the same time receive the advantage of our "Additional Sales Getting Plan." Remember, it is the Necessity That Sells.

"Utility Varnish Renovator" is sold with our GUARANTEE, thereby making a "safe bet" for both dealer and consumer.

List Prices:

4 ounce bottles, 25c      Quart cans, \$1.00  
12 ounce bottles, 50c      Gallon cans, 3.00  
Sprayer, 25c

**Poughkeepsie Utilities Corporation,**  
44 WINNIKEE AVENUE, POUGHKEEPSIE, N. Y.



Meet me at the Tuller for Value, Service, Home Comforts

NEW  
**HOTEL TULLER**  
Detroit, Michigan

Center of business on Grand Circus Park. Take Woodward car, get off at Adams Avenue.

ABSOLUTELY FIREPROOF

200 Rooms, Private Bath, \$1.50 Single, \$3.00 Up Double
200 " " " 2.00 " 4.00 " "
100 " " " 2.50 " 4.50 " "
100 " " " 3.50 to 5.00 " 5.00 " "

Total, 600 Outside Rooms

ALL ABSOLUTELY QUIET

Two Floors—Agents' Sample Rooms

New Unique Cafes and Cabaret Exellente

## Here's the Evidence—

that should impel you to investigate the case of the

### Simmons' Standard No. 6 Universal Grinding Machine

It has massive table, micrometer adjustments, very long knee and gibs, and extra heavy head and tailstock.

Headstock is fitted with large bearing for chuck spindle and with special bronze bearings of navy specifications; spindle is tapered and bored to take wheel arbors, and bearings are 1 in. in diameter and 2 3/4 in. long; exceptionally simple and sturdy countershaft, and has self-lubricating bearings.

We'll help along your investigation—write for the details TODAY.

**Simmons Machine Co., Inc.**

1001 Singer Bldg., New York City  
981 Broadway, Albany, N. Y.

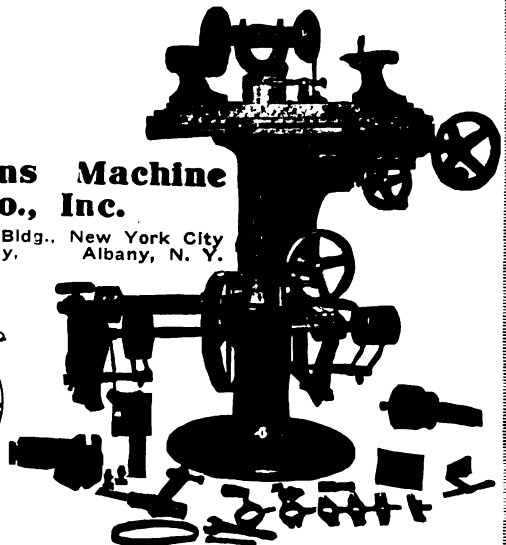

Please mention "The Hub" when you write

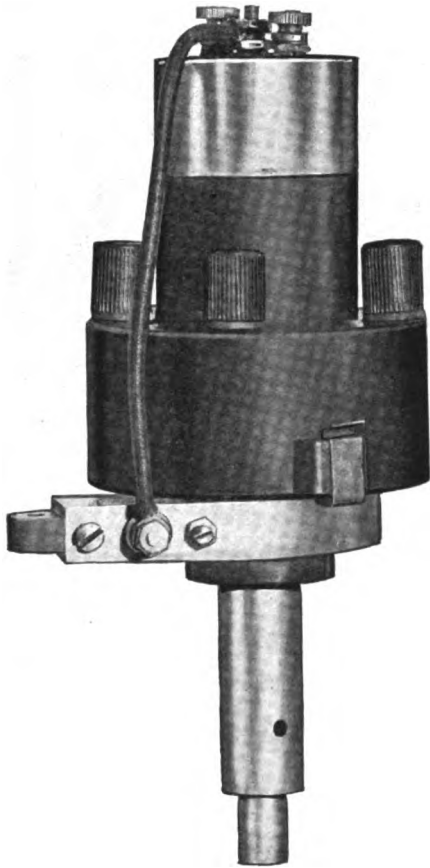

## A Perfectly Synchronized Spark at ALL Speeds

"Pittsfield" Distributor is of unit construction. It has an absolutely mechanical make and break which is positive and independent of spring action. No trips, hammers or other unreliable devices are required or used.

Its make and break is positive, giving a perfectly synchronized spark at all speeds. There is no lag in the spark—no automatic advances required.

Send for folder fully describing the "Pittsfield"

### FORD OWNERS

We have developed a special bracket for installing the "Pittsfield" Distributor on Ford Cars. Send for Folder.

Also manufacturers of "Pittsfield" Coils, Timers, Switches, "Berkshire," "Jewell," and "Micatite" Spark Plugs.

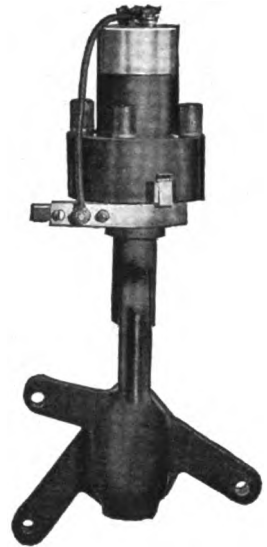

## PITTSFIELD SPARK COIL CO.

PITTSFIELD, MASS.

# MACHINEBRONZE

THE UNIVERSAL  
BEARING BRONZE



Carried in stock in solid and cored bars of 12" lengths—  
1/8" to 4 1/2" diameter, inclusive, by 1/8ths

Are Your Machines  
*Making* Money, or  
*Costing* Money?

Are your machines running steadily and MAKING money, or are they continually "down" for repairs and thus COSTING money?

If they are "down," worn bearings is probably the cause, as is the case nine out of ten times.

If you put cheap bearings in those machines that are "down," you'll no doubt have them "down" again in a short while.

It always pays to build them up with the best bearings you can buy. Bearings made of Machinebronze will cost you a little more, but consider the future shutdowns and overhauls they will save you.

You will be interested in our booklets.  
Send for them today

## LUMEN BEARING COMPANY

BRASS FOUNDERS

BUFFALO

Please mention "The Hub" when you write

# Keritol LEATHER SKINS

For the car where leather has always been used



**PRICE**  
*Within Reason*  
**QUALITY**  
*Maintained*

**W<sup>m</sup> L. BARRELL Co.**      **8 THOMAS ST.**  
**NEW YORK**

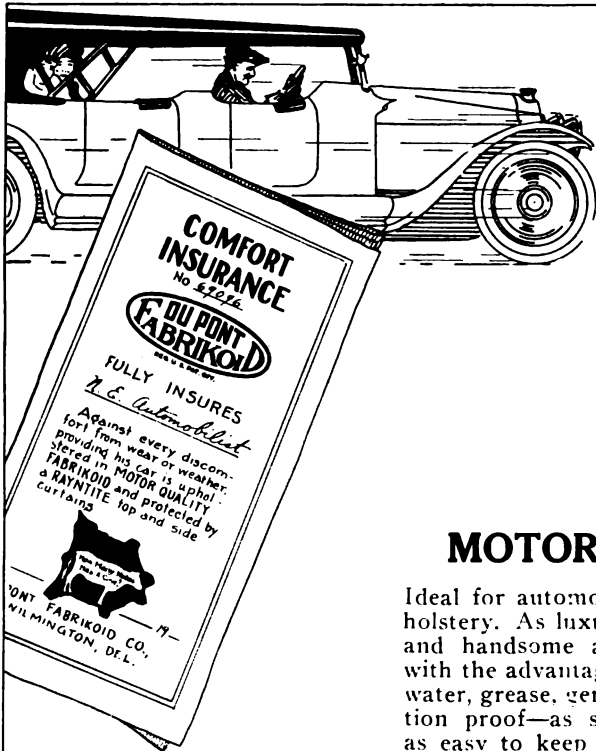

## Comfort Insurance Is Free

You pay for Fire Insurance.  
You pay for Accident Insurance.  
Comfort Insurance is a matter of  
policy in selecting



REG. U. S. PAT. OFF.

The Best Leather Substitute

### MOTOR QUALITY

Ideal for automobile and carriage upholstery. As luxurious, soft, satisfying and handsome as the finest leather, with the advantage of being absolutely water, grease, germ, stain and perspiration proof—as sanitary as glass and as easy to keep clean.

### RAYNTITE

The safest material to use for tops and side curtains on automobiles, boats and carriages. Gives absolute protection, unequalled beauty and serviceability. Guaranteed not to leak, crack or peel for one year—built to last the life of the car.

Write for Samples and Booklet

**DU PONT FABRIKOID CO. WILMINGTON, DEL.**

One of the  
 Steels of the Century  
**Centurion High-Speed**

Made from the **BEST** Materials  
 Iron, Tungsten, Chrome, Vanadium

Melted by the **BEST** Process  
 The Crucible Furnace Method

Handled by the **BEST** Workmen  
 Melters, Forgemen, Annealers, Metallurgists

*Consequently*  
 Will do the **BEST** Work

---

*Quality*

*Delivery*

*Service*

---

*We have a catalog waiting for you. Write for it.*

**THE CENTURY STEEL CO. OF AMERICA**  
 Manufacturers of High-Grade Crucible Steels

**Works:**  
 POUGHKEEPSIE,  
 N. Y.

**Sales Office:**  
 120 BROADWAY,  
 NEW YORK

Please mention "The Hub" when you write.

# BUSY BUYERS BRIEFS



Manufacturers  
**FIFTH  
WHEELS**  
All Varieties  
Heavy Goods a  
Specialty

Iron and Steel Rings from 4 to  
60 inches wide  
**MILLERSBURG FIFTH WHEEL CO.**  
Millersburg, Pa.

WE MANUFACTURE

**FINE VEHICLE**

## WHEELS

The Bookwalter Wheel Co.  
MIAMISBURG, OHIO

**JOHNSTON'S**

## KRAKNO

Color Card Free  
**\$3.50 per gallon**

The R. F. Johnston Paint Co.  
Cincinnati, Ohio

### Why Not Have the Best?



One of a Large Variety

**G. Cowles & Co.**  
NEW HAVEN,  
CONN.

## J. C. DECKER

MONTGOMERY, PA.

Manufacturer of

### Carriage, Skate and Pad Straps

Side Loops, Bridle Fronts, Tail Ties, etc.

### THE CHARLES WING CO.

Established 1848

Manufacturers and Wholesale Dealers In  
**AUTOMOBILE AND CARRIAGE  
HARDWARE AND TRIMMINGS**  
AMESBURY, MASS., U. S. A.

**CHARLES L. DOWLER**

CARRIAGE AND WAGON HARDWARE

108 North Third St., Philadelphia, Pa.

**CUSHION MANUFACTURER**

Pure Stearic Acid Candles. Wheel Stock. Snow  
Flake Axle Grease.

## MULHOLLAND BUGGY SPRING

Reduces weight of springs one-half.  
Made in one size only but will fit bodies  
of all widths.

Write for further particulars and prices.  
**THE MULHOLLAND CO.** DUNKIRK, N. Y.

### White's Brazing Sleeves



LINED



UNLINED

For applying Rubber Tires  
Send for Samples.

**WHITE-QUEHL MFG. CO.**

431 E. Pearl St.  
CINCINNATI, OHIO

## CLASSIFIED INDEX

For Addresses See Alphabetical Index  
and Advertising Pages

### AUTOMOBILES

American Motors Corp., Plain-  
field, N. J.

### AUTO FABRICS

Barrell, Wm. L., Co., New York  
Keratol Co., The, Newark, N. J.  
Laidlaw Co., Inc., The, New  
York.  
Standard Oil Cloth Co., New  
York City.

### AUTO PARTS

Hartford Auto Parts Co., Hart-  
ford, Conn.

### AXLES (Including Ball and Roller Bearing)

Sheldon Axle & Spring Co.,  
Wilkes-Barre, Pa.

### BODIES

Bela Body Co., Framingham,  
Mass.

### BOLTS AND NUTS

Columbus (O.) Bolt Works Co.  
Russell, Burdall & Ward Bolt  
& Nut Co., Fort Chester, N.Y.

### BOLT CLIPPERS

Porter, H. K., Everett, Mass.

### BRAZING SLEEVES

White-Quehl Mfg. Co Cincinnati,  
O.

### BRONZE BEARINGS

Lumen Bearing Co., Buffalo.

### DIES

Bliss Co., E. W., Brooklyn, N.Y.  
(Sheet Metal Working).

### FORGINGS

Eccles, Richard, Auburn, N. Y.  
(Carriage, Drop).  
Williams, J. H., & Co. Brook-  
lyn, N.Y. (Automobile, Drop)

### FIFTH WHEELS

Millersburg Fifth Wheel Co.,  
The, Millersburg, Pa.  
Wilcox Mfg. Co., D., Mechanics-  
burg, Pa.

### HARDWARE (Carriage, Wagon and Automobile)

Columbus (O.) Bolt Works Co.  
Dowler, Chas. L., Philadelphia.  
Eccles Co., Richard, Auburn,  
N. Y.  
Wilcox Mfg. Co., D., Mechan-  
icsburg, Pa.  
Wing Co., Chas., Amesbury,  
Mass.  
Cowles, C., & Co., New Haven,  
Conn.

### LEATHER SUBSTITUTES

Barrell Co., Wm. L., New York.  
Keratol Co., The, Newark, N. J.  
Standard Oil Cloth Co., New  
York.  
DuPont Fabrikoid Co., Wil-  
mington, Del.

### LUBRICANTS

Dixon, Jos., Crucible Co., Jer-  
sey City, N. J.

### MACHINERY AND TOOLS

Bliss Co., E. W., Brooklyn, N.Y.  
Norton Grinding Co., Worces-  
ter, Mass.  
Pettingell Machine Co., Ames-  
bury, Mass.  
Simmons Machine Co., Inc.,  
Albany, N. Y.; Singer Bldg.,  
New York City.  
Smith, H. Collier Detroit, Mich.  
West Tire Setter Co., Roches-  
ter, N. Y.  
Williams, J. H., & Co., Brook-  
lyn, N. Y.  
White-Quehl Mfg. Co., Cincin-  
nati, O.  
Yoder Co., The, Cleveland, O.

### MACHINERY (Metal Working)

Bliss Co., E. W., Brooklyn, N.Y.  
Pettingell Machine Co., Ames-  
bury, Mass.  
Quickwork Company, Detroit,  
Mich.  
Yoder Co., The, Cleveland, O.

### MAGNETOS

Berkshire Magneto Co., Pitts-  
field, Mass.

### METAL STAMPINGS AND NOVELTIES

Gray, Peter, & Sons, Inc., Cam-  
bridge, Mass.  
Murcott-Duden Co., Inc., New  
York.  
Pressed Steel Co. of New York,  
New York City.

### MOTORS

Brennan Motor Mfg. Co. Syra-  
cuse, N. Y.

### PATENTS

Jenner, H. W. T., Washington,  
D. C.

### PAINTS AND COLORS

Johnston Paint Co., R. F., Cin-  
cinnati, O.  
Pierce Co., F. O., New York.  
Willey Co., C. A., Hunter's  
Point, N. Y.

### PRESSES

Bliss Co., E. W., Brooklyn, N.Y.  
(Drop, Power).

### RADIATORS

G. & O. Mfg. Co., New Haven,  
Conn.  
Rome-Turney Co., Rome, N. Y.

### SCHOOL FOR DRAUGHTS- MEN

Mechanics' Institute, New York

### SHAFT COUPLINGS

Bradley & Son, C. C., Syracuse,  
N. Y.  
Eccles Co., Richard, Auburn,  
N. Y.

### SPARK COILS

Pittsfield Spark Coil Co., Pitts-  
field, Mass.

### SPRINGS

Mulholland Co., Dunkirk, N. Y.  
Sheldon Axle & Spring Co.,  
Wilkes-Barre, Pa.

### STEEL

Century Steel Co. of America,  
Poughkeepsie, N. Y.; Sales  
office, 120 Broadway, N. Y.

### TIRES

Century-Plainfield Tire Co.,  
Plainfield, N. J.

### TOOLS

Williams, J. H., & Co. Brook-  
lyn, N. Y.

### TRIMMING MATERIAL

Bridgeport (Conn.) Coach Lace  
Co.  
Decker, J. C., Montgomery, Pa.  
Wing Co., Chas., Amesbury,  
Mass.

### UNIVERSAL JOINTS

Hartford (Conn.) Auto Parts  
Co.

### VARNISH AND JAPAN

Parrott Varnish Co., Bridgeport,  
Conn.  
Pierce Co., F. O., New York.  
Willey Co., C. A., Hunter's  
Point, N. Y.

### VARNISH RENOVATOR

Poughkeepsie (N. Y.) Utilities  
Corp.

### WHEELS

Crane & MacMahon, Inc., New  
York City.  
Hoopes Bros. & Darlington,  
Inc., West Chester, Pa.

### WOOD BENDINGS, WHEEL STOCK, ETC.

Crane & MacMahon, Inc., New  
York City.

Please mention "The Hub" when you write





**TEMPERED STEEL RING**

**LEATHER PACKING**

The Only One-piece Moulded Leather Packing

## The Bradley Carriage Coupler

All-Steel    Noiseless    Quick-Shifting    Ball-Bearing

(MADE IN FIVE SIZES FOR AXLES 1/4 INCH TO 2 1/4 INCH)

The *only* carriage coupler that is furnished with a **ONE-PIECE MOULDED LEATHER PACKING**

**C. C. BRADLEY & SON, Syracuse, N. Y.**

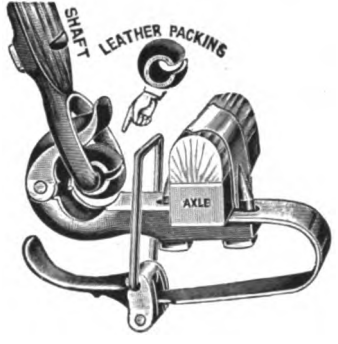

**SHAFT**    **LEATHER PACKING**    **AXLE**

The Bradley Carriage Coupler

# THE BRUNSWICK



**Boylston Street, Corner Clarendon,**  
(Facing Copley Square)

**BOSTON - - MASS.**

High class modern house, intelligent service, pleasant rooms, superior cuisine. Ladies traveling alone are assured courteous attention European plan, single rooms, \$1.50 up; with bath, \$2 up; double, \$2 up; with bath, \$3 up. American plan, \$4 per day up.

**FRED E. JONES - Proprietor**

## Sheet Metal Specialties



**WE** are in a position to furnish *Sheet Metal Stampings* in all kinds of metal at the rate of several hundred thousand pieces per day. Special attention given to rush orders. Send us your inquiry with specifications.

**Peter Gray & Sons, Inc.**  
Cambridge, Mass.

**"Quickwork"**      Sheet Metal Working Machinery

For Automobile and Carriage Bodies, Fenders, Hoods, etc.

**THE QUICKWORK CO.**

H. COLLIER SMITH, Pres. and Gen. Mgr. ST. MARYS, O.

**PORTER'S BOLT CLIPPERS**  
"Easy" "New Easy" Allen-Randall



To Cut 5-16, 3-8, 1-2, 5-8, 3-4 Inch.

**H. K. PORTER,**      **EVERETT, MASS.**

# RUSSELL, BURDSALL & WARD BOLT & NUT CO.

Established 1845      PORT CHESTER, N. Y.

**MAKERS OF THE CELEBRATED EMPIRE BOLTS AND NUTS**

Western Office: Continental & Commercial Bank Bldg., Chicago, Ill. Branch Works: Rock Falls, Ill.

Please mention "The Hub" when you write

# RADIATOR INSURANCE

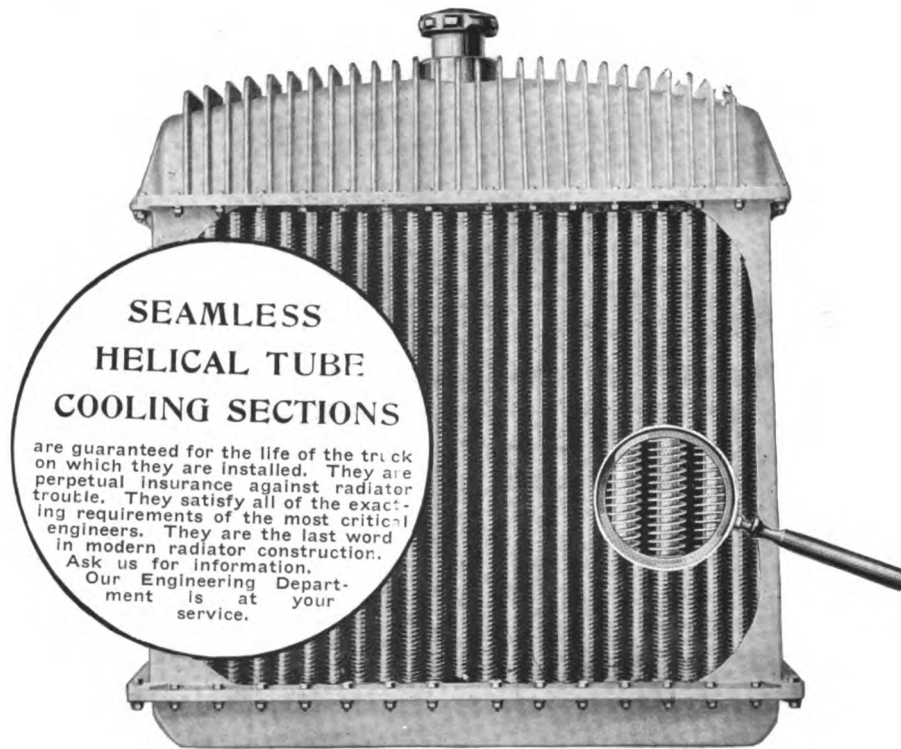

ROME-TURNEY RADIATOR CO., Sole Manufacturers, ROME, N. Y.

## WILLEY'S COLORS

The Recognized Standard



**C. A. WILLEY CO.**  
COLOR GRINDERS

and Manufacturers of Specialties in

**CARRIAGE, AUTOMOBILE and CAR**

**PAINTS**

**COLORS, VARNISHES, ETC.**

**HUNTER'S POINT, NEW YORK CITY**

## Automobile, Carriage, Wagon and Special FORGINGS

of Guaranteed Quality

When you are in the market, send us your blue-prints for quotations.

Ask for catalog showing part of our large line of Automobile and Special Forgings, also catalog listing our full line of Carriage and Wagon Hardware.

**Richard Eccles Co.**  
AUBURN, NEW YORK

ESTABLISHED IN 1880

Please mention "The Hub" when you write

# HOOPES BRO. & DARLINGTON

(INCORPORATED)

WEST CHESTER, PA.

WE ARE MAKING

# AUTOMOBILE WHEELS

Forty Years' Experience as WHEEL MAKERS is guarantee we can make good ones.  
Will not make any other kind. Try them.

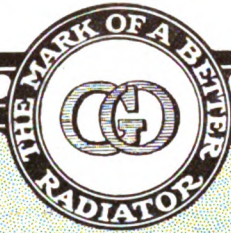

ENGINE COOLING

## RADIATORS

FOR PLEASURE CAR AND HEAVY DUTY SERVICE

G & O MFG. CO. - New Haven, Conn.

## WILCOX

FINE  
FINISHED  
FORGED

CARRIAGE HARDWARE  
AND GEAR IRONS

Write for Prices and Catalog

The D. Wilcox Mfg. Co.

MECHANICSBURG, PA.

## The WEST Hydraulic Tire Setter

WILL CUT DOWN EXPENSE

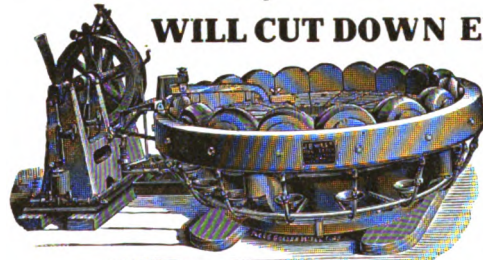

Tires set cold in one minute. This machine saves time—does the work better and quicker, does a way with burned streaks. Only necessary to measure one wheel in a lot. Does not char the rim, and

thus make the tire loosen prematurely. Saves resandpapering of wheels. This machine is now increasing the profits of many manufacturers. Send for catalog and read about it.

WEST TIRE SETTER CO., ROCHESTER, NEW YORK

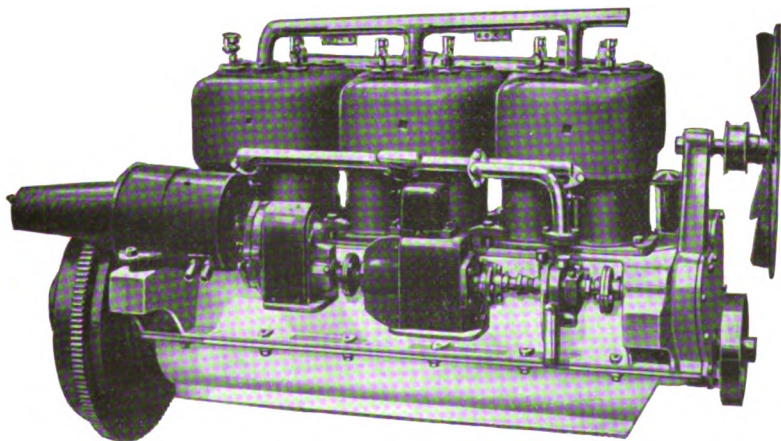

Model 6B Motor, 4½" bore by 5" stroke

## Quality and Service

are the two essentials that for 17 years have been built into

## BRENNAN STANDARD MOTORS

The manufacturer of Commercial or Pleasure cars who equips his product with Brennan Standard Motors can feel assured his every requirement regarding this vital part has been fulfilled.

Built in the following sizes:  
4 Cylinder Model M—4 x 5    4 Cylinder Model 12—5½ x 6  
4 Cylinder Model B—4½ x 5    4 Cylinder Model 12—6 x 6  
4 Cylinder Model 11—5 x 5    6 Cylinder Model 6B—4½ x 6

Let us send bulletins telling WHY Brennan Motors are STANDARD motors

Brennan Motor Mfg. Co., Syracuse, N. Y

Please mention "The Hub" when you write



## The Hub

# AUTO TRUCK

Hickory Nut and

BEST QUALITY STOCK  
TOUGH AND HEAVY  
BONE DRY

MANUFACTURED BY  
CAPABLE MECHANICS  
AND MOST  
IMPROVED MACHINERY

WHEELS WHICH ADD TO  
THE LIFE OF YOUR TRUCK

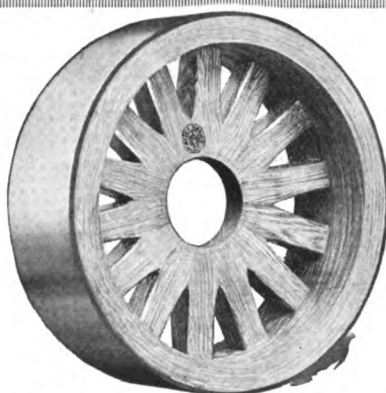

# WHEELS

Acorn Brands

HORSE-DRAWN  
VEHICLE WHEELS  
ALL STYLES

TRAILER WHEELS:  
SARVEN AND  
ARTILLERY TYPES

HIGH STANDARD OF  
QUALITY AND  
WORKMANSHIP  
MAINTAINED

ST. MARY S, OHIO

CRANE & MacMAHON, Inc.

8 BRIDGE ST., N. Y. CITY

# Yoder Sheet Metal Machinery

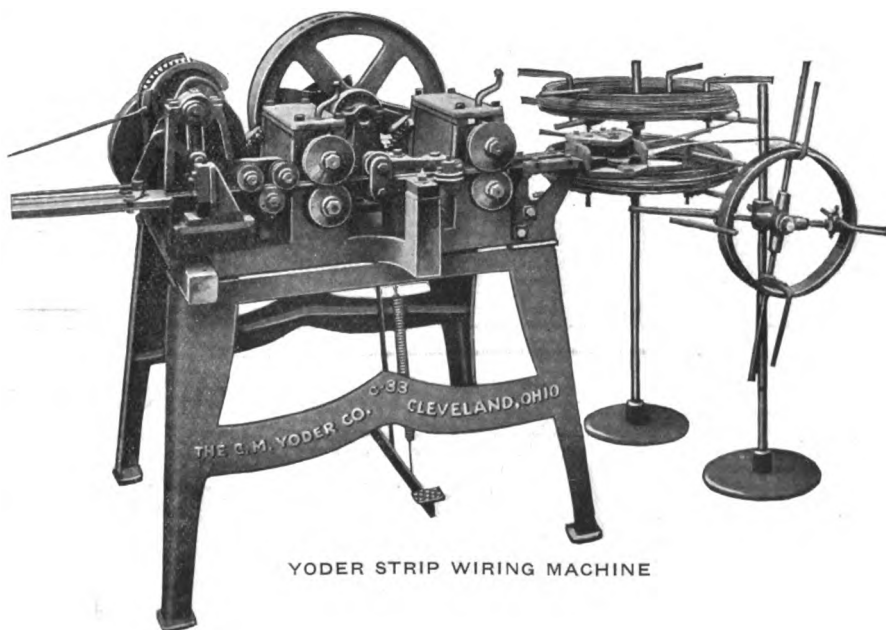

YODER STRIP WIRING MACHINE

Our line of Auto Sheet Metal Working Machinery is efficient in every detail.

Every machine is constructed with the objective of producing perfect results at a minimum cost of material and labor.

The Yoder Company guarantees its machinery to produce results satisfactory to the purchaser.

We are glad to consider your Sheet Metal Machinery needs, as well as your requirements for special machines.

If you are thinking of making your own sheet metal parts or producing sheet metal products for the trade, get in touch with us at once. We can save you money and furnish a most satisfactory and complete equipment.

Catalog and prices furnished on request

## THE YODER COMPANY

Engineers Building

CLEVELAND, OHIO

## Skewed Shaft Couplings

Regular or Oval Patterns  
For High Arched Axles

Furnished in rights and lefts for any height of arch.

Oval Axle Clips  $\frac{5}{8}$  or  $\frac{3}{4}$  width to match Oval Couplings. Bolts, Clips, Couplings, Carriage Hardware and Special Forgings

Catalogue "H" and Prices on Application

**COLUMBUS BOLT WORKS COMPANY**

COLUMBUS, OHIO

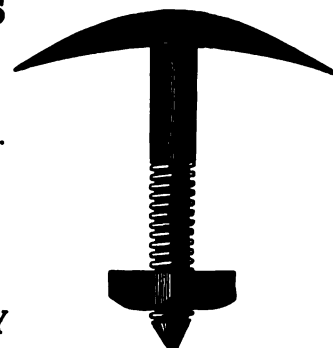
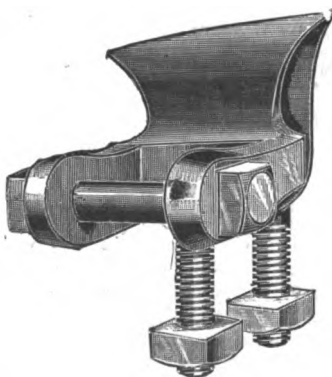

# The Hub

First Journal of the Vehicle Industry

Vol. LIX

NEW YORK, OCTOBER, 1917

No. 7



## Superior Drop-Forgings

insure strength and give one confidence in the dependability of motor cars. Drop and Steam Hammers from 300 to 12,000 lbs. capacity, trip hammers, upsetters and nearly all other types of forging equipment are available to those who

Order from the Home of  
Heat Treatment.

**J. H. WILLIAMS & CO.**

44 Richards St., Brooklyn, N. Y.

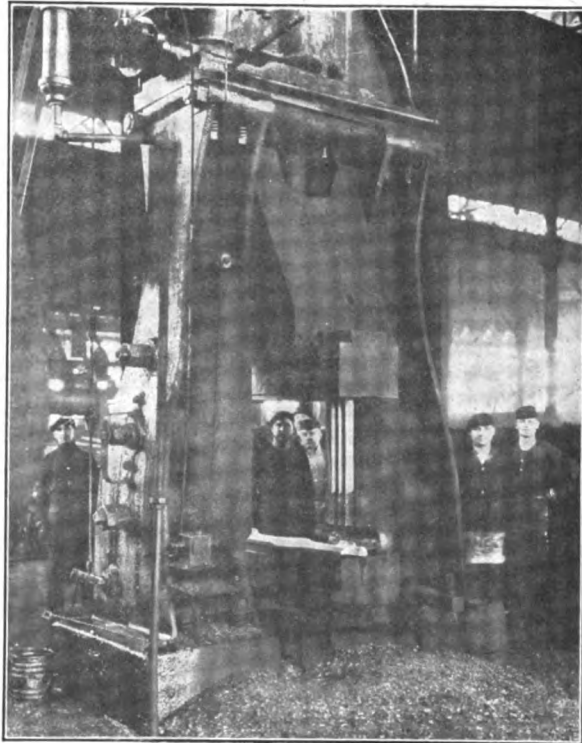

12,000 lb. drop hammer

# PARROTT VARNISHES



.. Unequaled for ..  
**Automobile  
and  
Carriage  
Finishing**

**The Parrott Varnish Co.**  
Bridgeport, Conn.

# AUTOMOBILE WHEELS

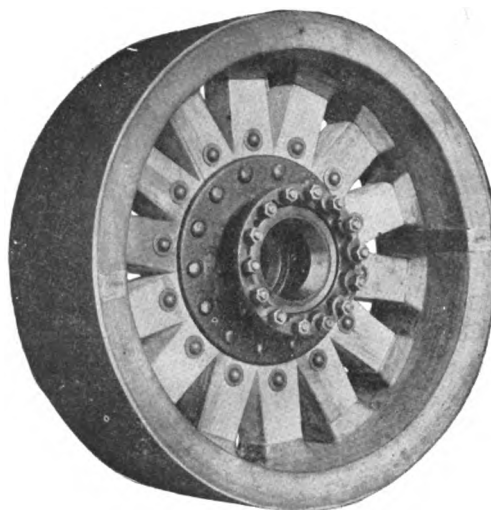

Have you seen our *new* construction?  
Better write us for particulars.

**Wayne Wheel Co.**  
Newark, Wayne Co., New York

# steel stampings

*especially for*  
**COMMERCIAL TRUCKS**

**The Pressed Steel Company**  
Wilkes-Barre, Pa.

The  
**Laidlaw Company**  
Inc.

New York City

.....

**Automobile  
Fabrics**

.....

**A Fabric for  
Every Purpose  
For Closed, Open or  
Convertible Bodies**



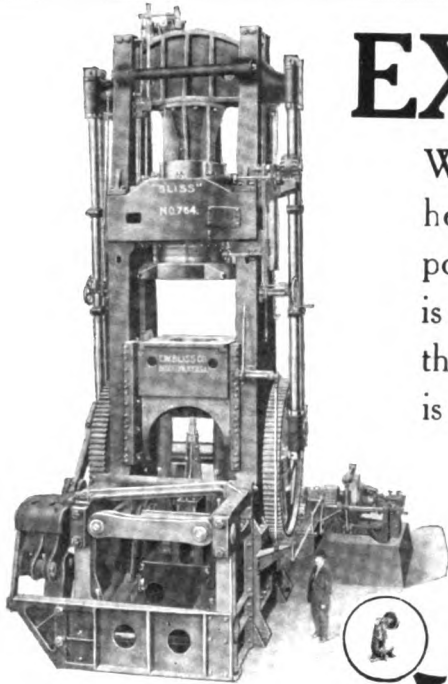

# EXTREMES MEET

We're showing you the "biggest and the littlest" here side by side just to point to a fact—that every power press need of the sheet metal manufacturer is covered by "BLISS" lines. The tiny press in the circle (not so tiny at that, for it weighs 250 lbs.) is a Bench Press suitable for punching, blanking and forming light work. The big one that towers above its operator is a *Bottom Slide Toggle Drawing Press No. 764* especially adapted for producing large, heavy steel barrels, etc.

WE BUILD BOTH THESE PRESSES



## E. W. BLISS COMPANY



Main Office and Works: BROOKLYN, N. Y., U. S. A.

CHICAGO OFFICE  
People's Gas Building

DETROIT OFFICE  
Dime Bank Building

CLEVELAND OFFICE  
Union Bank Building

LONDON, S. E., ENGLAND, Pooock Street, Blackfriars Road  
PARIS, FRANCE, 100 Boulevard Victor-Hugo St. Ouen

1857

1917

**Hartford**  
**Universal Joints**

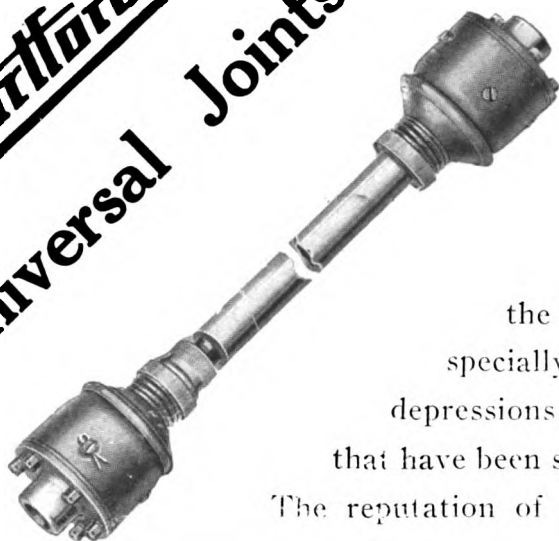

WE are able to offer manufacturers universal joints manufactured by specialists in one of the largest plants in the world.

The wearing surfaces of HARTFORD UNIVERSAL JOINTS are hardened and ground, the grinding being accomplished by a specially devised machine whose use eliminates depressions or elevations so common in steel parts that have been simply reamed.

The reputation of your car demands the best universal joints that can be made, and we have them.

# The Hartford Automobile Parts Co.

Established 1906

Hartford, Conn.

Please mention "The Hub" when you write.

# LOOK INTO IT

---

**The Sales agency for the AMERICAN SIX represents an unusual money-making opportunity for readers of The Hub.**

**Get the whole proposition from the factory, Plainfield, N. J.**

**The car is six-cylindered, of beautiful design, big, roomy and mechanically right.**

45 horsepower  
122 in. wheelbase

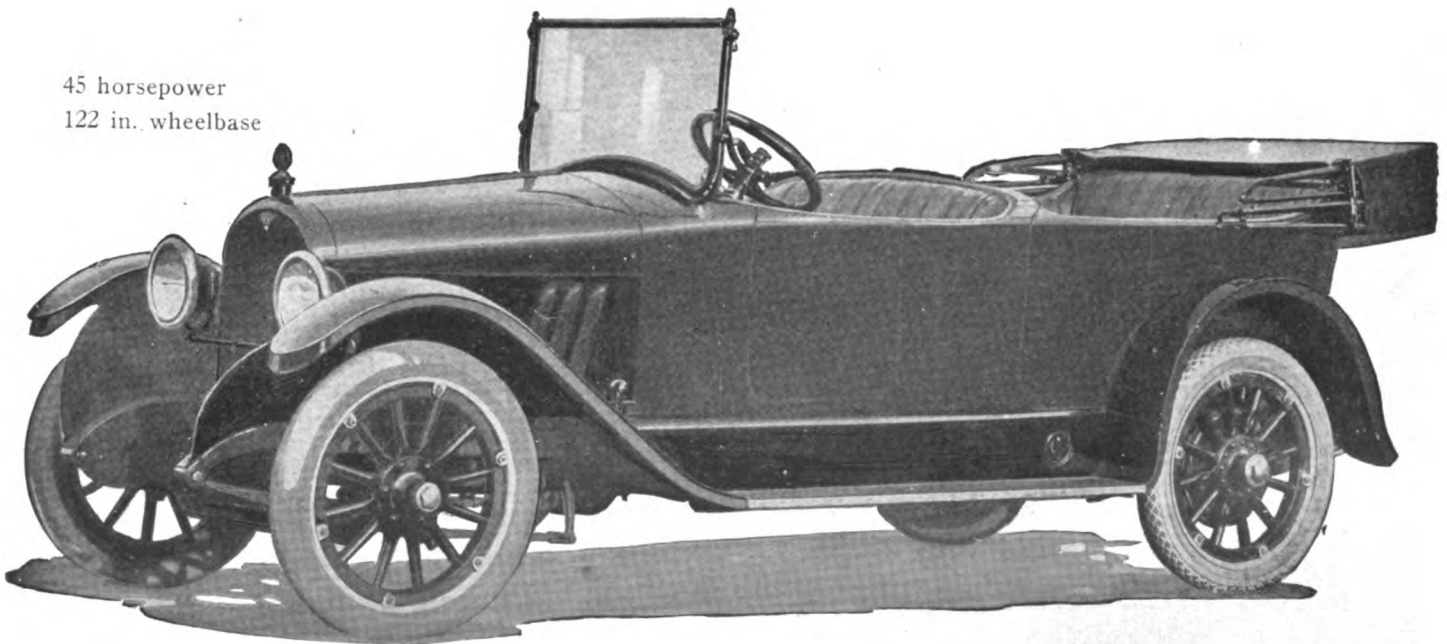

## AMERICAN SIX \$1375

---

**AMERICAN MOTORS CORPORATION, Plainfield, N. J.**

(25 miles from New York City)

Please mention "The Hub" when you write.

# Discriminating Buyers Choose Nortons

Big automobile manufacturers are the most discriminating buyers of machine tools in this country.

The grinding and finishing of their parts calls for the **utmost accuracy combined with speed.** For competition is keen in the automobile field, and cost of production is very closely watched.

The fact that most of these large automobile concerns, with hardly an exception, are using batteries of Nortons and have been steady customers for years, should carry conviction as to the real merit of Norton Grinders.

Why not consult with our Service Engineers on your grinding problems? You are welcome to their services without obligation.

## Norton Grinding Company

Worcester, Mass.

Chicago Store: 11 North Jefferson Street

### AGENTS

Vonnegut Machinery Co., Indianapolis; Robinson, Carey & Sands Co., St. Paul and Duluth; Manning, Maxwell & Moore, Inc., St. Louis; The Motch & Merryweather Machinery Co., Cleveland, Pittsburgh, Cincinnati and Detroit; Eccles & Smith Co., San Francisco, Portland (Ore.) and Los Angeles; Henry Prentiss & Co., Inc., New York, Boston, Rochester, Buffalo, Syracuse, Scrant-

### AGENTS

ton; Canadian Fairbanks, Morse Co., Montreal, Toronto, Winnipeg, Vancouver; Alfred Herbert, Ltd., Coventry (England), Paris and Milan; F. W. Horne Co., Tokio, Japan; The W. E. Shipley Machinery Co., Philadelphia; Kemp Machinery Co., Baltimore; C. T. Paterson Co., New Orleans; Post Van der Burgh & Co., Rotterdam; Iznoskoff & Co., Petrograd, Moscow and Ekaterinburg, Russia.

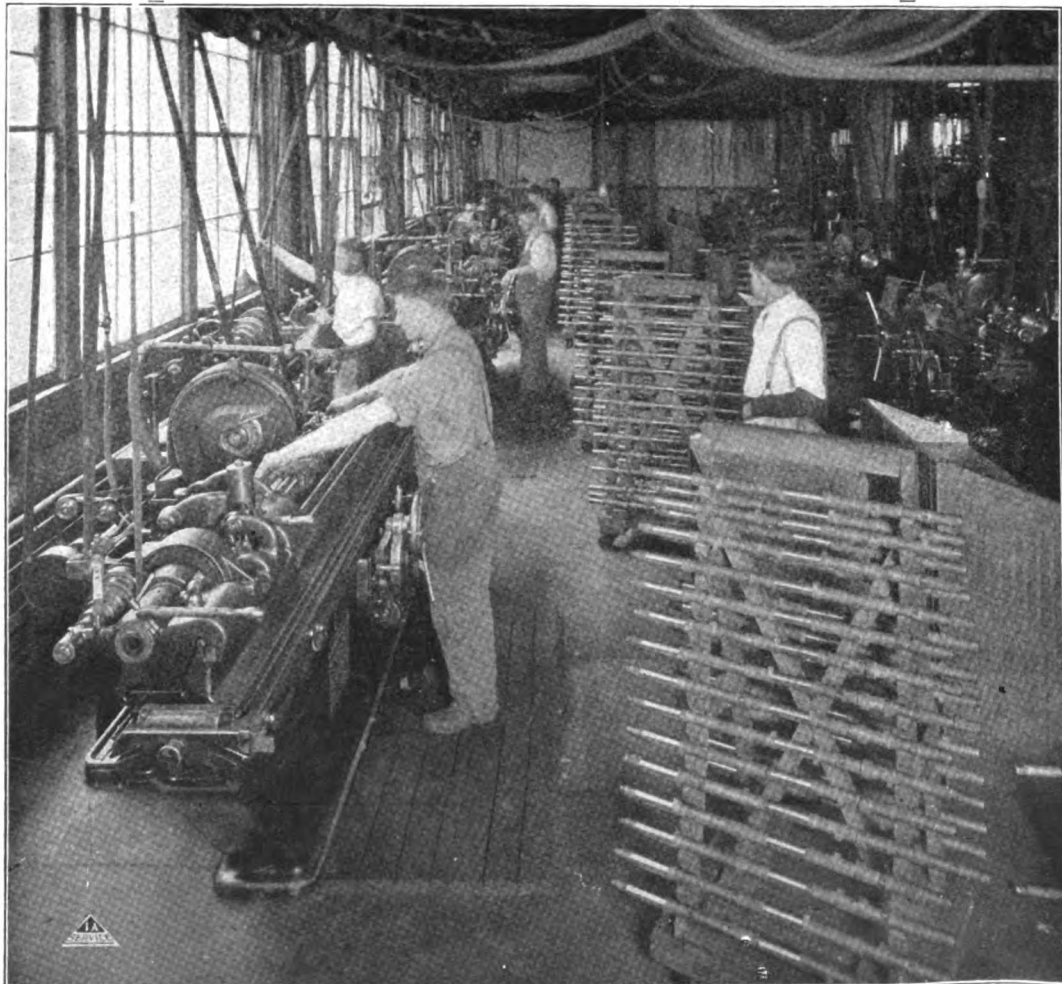

Please mention "The Hub" when you write

# MERITAS

## LEATHER CLOTH

### The Only Standard Leather Substitute

Meritas Leather Cloth is the leading leather substitute.

It is the real "standard" quality manufactured by The Standard Oil Cloth Company.

So-called "standard" leather cloths not bearing the Meritas Leather Cloth are not our goods and we cannot be responsible for them.

We are the world's largest manufacturer of leather cloth, operating five enormous plants.

You can get any weight, color, grain or finish in Meritas Leather Cloth.

We make a style for every carriage and automobile upholstery requirement.

Always look on the back of the goods for the trademark Meritas Leather Cloth.

Samples on request

**The Standard Oil Cloth Company**

INCORPORATED

320 Broadway

New York



Please mention "The Hub" when you write

---



---

**THE**

**United States Government  
Canadian Government  
British Government**

**are using PETTINGELL Machines,**

**the Standard for quality and production the world over.  
They will save time, money and disappointments on**

**AIRPLANE BODY WORK**

**When you want the best order  
PETTINGELL MACHINES**

**Bevel and Mitre Saw Tables                      Improved Saw Tenoners  
Irregular Shapers**

---

**Automatic Power Hammers                      Friction Drive Rotary Metal Cutters  
Beading and Moulding Formers                      Rolling Machines  
Foot Presses                      Cornice Brakes, Etc.**

---

**MANUFACTURED BY**

**THE PETTINGELL MACHINE CO.**

**AMESBURY, MASSACHUSETTS**





# EMPIRE STEEL TUBING

far excels ordinary tubing. It is especially prepared for the manufacture of *Automobiles, Auto Trucks, Aeroplanes, Motorcycles, Bicycles, Tricycles, Velocipedes, Beds, Baby Carriages, Pumps, etc.*

Made round or square, with welded, lock or open seams.

If you wish to manufacture products of the highest character insist upon *Empire Steel Tubing.*

**EMPIRE**  
**ART METAL CO**  
INCORPORATED  
**COLLEGE POINT, N.Y.**



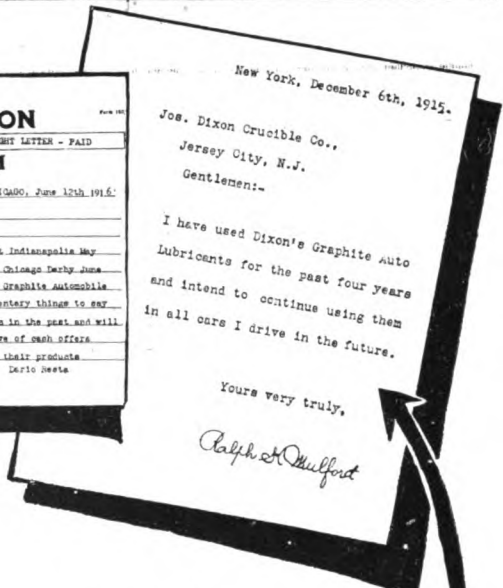
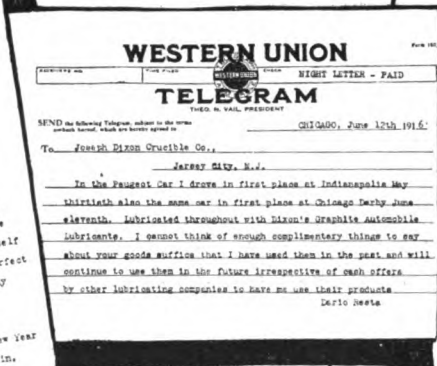
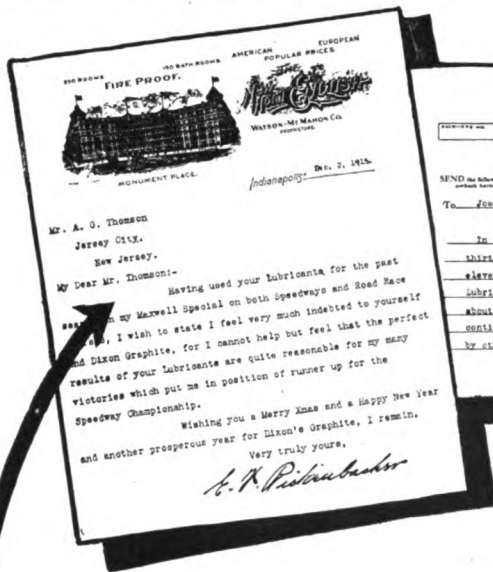

## What Speed Kings Think of

# DIXON'S GRAPHITE Automobile LUBRICANTS

Eddie Rickenbacher writes, "I feel very much indebted to Dixon's Lubricants, for I feel the perfect results of Dixon's are quite responsible for my many victories."

Ralph Mulford writes, "I have used Dixon's Lubricants since 1911 and intend to continue to use them in all cars I drive."

Dario Resta says, "I cannot think of enough complimentary things to say about Dixon's Lubricants. Suffice that I have used them in the past and will use them in the future."

Racing drivers take their lives in their hands every time they enter a race—and the greatest risk they run is that of friction. Think of the tremendous strain put on every bearing, the enormous heat generated. Life and limb are the greatest stakes that figure in any auto race.

Every well-informed racing driver lubricates his car with Dixon's Graphite Automobile Lubricants. They know that their bearings when thus lubricated are safe against lubricating failures.

Here's a hunch to the everyday driver of pleasure or commercial cars—Dixon's prevent that metal-to-metal contact which makes Friction, and Friction spells ruin for your car.

Write for Booklet No. 123-G telling more about these lubricants.

Made in Jersey City, N. J., by the

## JOSEPH DIXON CRUCIBLE COMPANY

ESTABLISHED 1827



# MALLEABLE IRONS

... FOR ...

CLASS A AND B

U. S. ARMY

MOTOR TRANSPORT BODIES



MADE BY

THE EBERHARD MFG. CO.

CLEVELAND, O.

Please mention "The Hub" when you write.

# When a Tire Pump Is Needed You Want the Best Ever Made

An automobile with a flat tire is as help-  
less as an aeroplane with a broken wing

## THE VICTOR



**MAKESHIFT PUMPS  
GIVE ASSURANCE  
UNTIL NEEDED  
MOST—THEN  
THEY FAIL**

**THE BEST  
PUMP MADE—  
GIVES MORE  
ASSURANCE AND  
REAL SERVICE**

**THE VICTOR**  
Is a triple compressor.  
Its tubes are of seam-  
less brass, of course.  
Its cups of selected  
stock.  
It is simple and quick  
in getting results.

**When needed it can be depended upon, and it  
gives you comfort to know it is in the tool box**

**Everywhere in demand**

**It provides for the greatest need of the motorist**

**Judd & Leland Mfg. Co. Clifton Springs,  
N. Y.**

**Please mention "The Hub" when you write.**

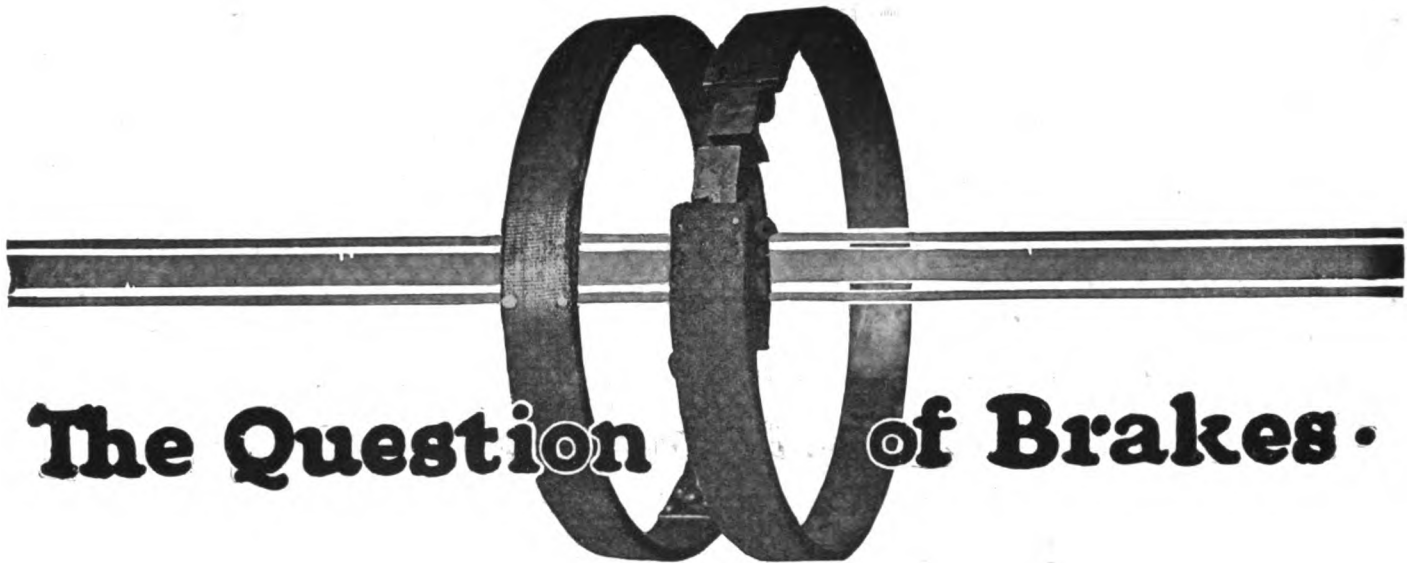

# The Question of Brakes.

**These Brake Bands Have Piled up a Mileage of 19,376 Miles and Are Good for Half Again That Distance**

**T**HE brake bands shown above have been driven almost 20,000 miles without adjustment, and are still good.

What is more, they have made this mileage record on a Fifth Avenue Bus.

And on a Fifth Avenue Bus 20,000 miles means something.

Fifth Avenue Buses use their brakes more than thirty-five times to a mile—and fully a third of the applications are for quick stops.

*The Fifth Avenue Coach Company knows that they could not have made this service record with any brakes other than Sheldon.*

This is one of the reasons why they have standardized Sheldon Worm Gear Rear Axles.

*Sheldon Brakes are one of the factors that have made Sheldon Worm Gear Semi-floating Rear Axles superior to all other rear axles.*

These double internal expanding brakes have no equal for positive dependable service.

They have generous bearing surfaces and are doubly enclosed to thoroughly protect the bearing surfaces from grit and mud. This reduces wear to a minimum.

The brakes are easily accessible for relining without removing the wheels.

For adjustment it is not necessary to touch the brakes themselves. They are tightened simply by moving back the sector, to which the brake pull lever is bolted, and inserting the lever bolt in the next hole (see illustration below).

The perfecting of Sheldon Brakes is typical of every feature of Sheldon Worm Gear Rear Axles. You will find every part designed and manufactured with the sole idea of strength, safety and accessibility. This means longer life and better service.

See that the truck you buy is equipped with Sheldon Worm Gear Rear Axles. Look for the double anchor.

**Sheldon Axle & Spring Co.**  
Makers of Springs and Axles for Heavy Duty Service for Over Fifty Years.  
Wilkes-Barre Penna.

## SHeldon WORM GEAR AXLES

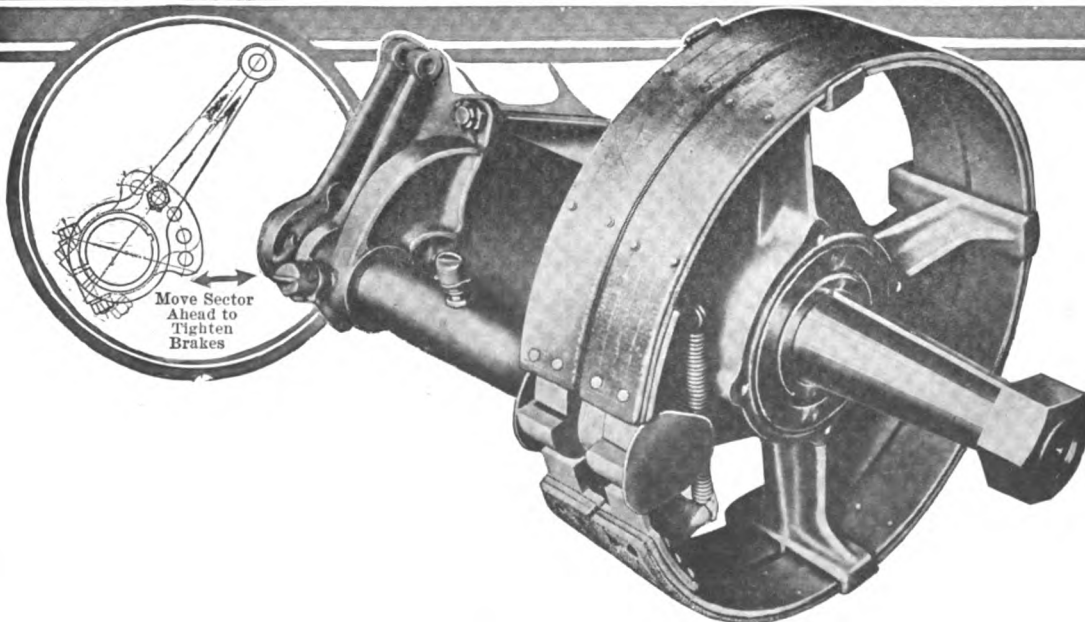

Please mention "The Hub" when you write

# The Hub

Vol. LIX

NEW YORK, OCTOBER, 1917

No. 7

Published Monthly by

## THE TRADE NEWS PUBLISHING CO. OF N. Y.

PAUL MORSE RICHARDS, *President* G. A. TANNER, *Secretary and Treasurer*

EDISON BUILDING, COR. ELM AND DUANE STS., NEW YORK

THE HUB, a monthly authoritative journal on all subjects pertaining to the vehicle industry from its engineering and construction viewpoints. It publishes information of live interest to manufacturers of motor vehicles, trailers, carriages, wagons, the accessory trades, repair shops and garages.

Subscription price for the United States, Mexico, Cuba, Porto Rico, Guam, the Philippines, and the Hawaiian Islands, \$2.00; Canada, \$2.50; payable strictly in advance. Single copies, 25 cents. Remittances at risk of subscriber, unless by registered letter, or by draft, check, express or post-office order, payable to the order of THE TRADE NEWS PUBLISHING CO.

For advertising rates apply to the publishers. Advertisements must be acceptable to publishers. Copy for new advertisements must be received by the 25th of the preceding month. All communications must be accompanied by the full name and address of writer.

Entered in the New York Post Office as Second-class Matter

## Graduated Taxation

The graduated scale of taxation is a more practical method of reaching large profits than graduated price-fixing, and the new revenue bill has employed it very effectively. The measure was first framed with the intention of taxing only the excess of war-time profits over pre-war profits, but in its final form it applies to the excess of all profits above 7 to 9 per cent on invested capital. Some latitude is allowed to cover cases where profits during the years adopted as the base were below normal. In conference the measure has been liberalized in some degree in the determination of what may be included as capital.

There is much to be said on general principles against the whole scheme of graduated taxation, particularly as applied to earnings in business, but it is true that when the nation needs money in time of war ordinary rules cannot govern. In normal times the true policy for the state is to look to the future, and adhere to principles which will promote thrift, industry and progress. Profits which become capital and are used for increasing production are the most powerful agency for social advancement. But in a crisis like the present the energies of a people must be concentrated upon the great task in hand. Industrial development is necessarily curtailed except as it is directly helpful in the war. Capital cannot be invested as usual, because labor and materials are not to be had. Under the circumstances taxation must be heavy and the people are reconciled to it. The fear about it has been that Congress might be misled by exaggerated representations about profits. A large part of the nominal profits of the present time will never be realized as real profits.

They exist in inventories of higher priced materials, and in brick and mortar and high priced machinery, and will disappear when inventories have to be readjusted after the war.

## Price-Fixing

The price-fixing negotiations which have been an element of disturbance in the markets have progressed far enough to remove some of the uncertainty. The copper price, 23½ cents per pound, is accepted as fair. The fixing of steel prices is much more complicated, because of the materials which are involved and the relations which must be maintained between products of various stages of manufacture. As in the case of copper, steel prices were reached by conference and agreement.

The price-fixing authorities have been most perplexed over the task, which at first they seemed to think it necessary to assume, of adjusting prices to suit different costs, and particularly as between the producers who control all stages of manufacture and those who cover only one or more stages of the process. It is a favorite theory in some quarters, says the National City Bank monthly bulletin, that if different companies mine ore, do the transportation, make coke, produce pig iron, billets, etc., and conduct the several processes up to the finished goods independently, they are each entitled to a manufacturer's compensation, but that if one organization conducts all of the operations, co-ordinating and harmonizing them, it is entitled to only one manufacturer's profit. In the past the gains resulting from improved methods in the industries have been deemed as fairly belonging to those who devise and introduce the new methods, so long as they can hold them, as a proper reward and encouragement for initiative. Industry changes constantly, and all such economies reach the entire community in due time. There is gain to the community wherever economies are effected, no matter who the immediate beneficiaries may be, and the public has much more to gain by encouraging improved methods than by attempting to arbitrarily seize upon the savings which result from them.

## Truck Standardization

The farm wagon department of the National Implement and Vehicle Association, which has made a number of very beneficial changes in wagon and truck construction within the last few years, has recommended another which has created a great deal of favorable comment as well as some criticism because it contemplates a rather marked departure from old customs.

The farm truck, as is well known, is a farm utility and convenience rather than a vehicle, its function being the moving of loads about the farm. At the present time the rear wheels, like those of a wagon, are higher than the front, for which there is no sufficient scientific reason; they are built that way simply because it has been the custom to do so.

The automobile manufacturers figured wisely when they made all four wheels the same height and so provided that in case of repair all wheels would be interchangeable. Farm truck wheels are constructed generally as low as automobile wheels and there is no perceptible difference in draft because the rear wheels are a little higher than the front, therefore, in order to gain many of the advantages the automobile manufacturers have gained in having all wheels the same height, the members of the truck department of the association, at their last meeting, passed the following recommendation:

"That it is the sense of this meeting that in order to create a marked distinction between trucks and wagons and to advance the utility of the truck, it is hereby recommended that truck wheels shall not be constructed of greater diameter than 36 in. and that the front and rear wheels be made of the same size and interchangeable."

The comments on this change have been largely favorable and the objections very few and not of a very substantial character. It may be expected, therefore, that early in the coming year, if not before, many trucks will appear constructed as above. It is believed that this construction will make a better truck for the farmer and, if he uses several, the fact that all wheels are interchangeable will enable him, in case of accident to utilize wheels from any of his trucks. A little change in the gear construction will enable the bed to be leveled and with a shortening of the spokes, greater strength will be given to the wheels.

The farm wagon department invites comments from dealers and users of trucks, which should be addressed to the Farm Wagon Department of the National Implement and Vehicle Association, 76 West Monroe street, Chicago, Ill.

### Industrial Co-operation Big War Need

To bring about immediate action by American business on the resolution passed at the recent war convention at Atlantic City recommending that each industry form a committee to represent that industry and to serve as a connecting link between it and the government, suggestions are given in a war bulletin issued by the committee of the Chamber of Commerce of the United States co-operating with the Council of National Defense.

To the established business of the country, the bulletin declares, it is vital that the vast requirements of the government for material and labor be met in a manner to interfere as little as possible with essential industry and in a way to maintain as far as possible in these abnormal times the normal structure of business.

#### Industrial Problems to Be Solved

"Many lines of industry," the bulletin continues, "are seriously affected by inability to get necessary material or labor and face serious problems for the future in connection with the shifting of labor from one community to another. Because these are problems, not only of the individuals in an industry, but of the industry as a whole,

the industry should organize and act in the common interest. These are problems not only of business but also for the government because it is essential to the winning of the war that the industrial life of the country be maintained in sound condition.

"Furthermore the government to procure war materials and supplies in the vast quantities required, needs the advice and assistance of men having thorough acquaintance with each industry. Also the government is confronted with great problems in connection with the regulation of prices and distribution and to avoid unnecessary interference with business, needs at its service the practical knowledge and experience which could be furnished by such committees."

#### Much Could Be Accomplished by Committees

It is thought, according to the bulletin, that such war service committees might undertake the following:

1. To assemble accurate information with respect to the facilities of the industry, the possibilities of expansion or the readjustment of plants and equipment to meet the ever increasing requirements of the government.

2. To arrange for the gathering of figures as to cost of production in the industry including conditions which were changing the cost of production. In this respect the committee would furnish to the government information which would prevent avoidable hardship in the business by government regulation of prices or distribution.

3. To act with the priority committee of the war industries board which is establishing principles governing the distribution of materials in transportation and the order in which various products are to be produced and distributed. The work of the priorities committee calls for an immense organization and the quick adjustment of industry to the demands of the priority system. A war service committee representing an entire industry can be of great value in dealing with priority questions with relation to that industry.

4. New facilities are being created and there is great shifting of labor from one section of the country to another. War service committee could offer suggestions regarding the use of existing facilities or the employment of labor in districts of the country where needed after the war.

5. These committees should be ready at all times to meet with any of the departments of the government whenever their advice is desired, to discuss questions affecting the industry raised by the war needs of the government. The committees might also, on their own initiative, present to the government questions which call for consideration, and might from time to time suggest on behalf of the industry how orders and material can be distributed to the best advantage, and with the least disturbance to existing or prospective conditions.

It is important, the bulletin points out, that meetings for the selection of war service committees be held at the earliest possible moment. It was the unanimous vote of the Atlantic City convention that the Chamber of Commerce of the United States be requested to bring to the attention of all industrial interests the need of prompt action and give its aid in every possible way in the formation of committees.

#### Committees Must Be Thoroughly Representative

In selecting the war service committees the bulletin emphasizes the following:



A—All branches of the industry should be represented on the committee, whether members of a trade organization or not.

B—It is important that the committee should include representatives of some of the smaller units of the industry as well as the larger.

C—To be in a position to render efficient service, the committee should not necessarily be made up of the presidents of the largest units of the business or of the best known men, but should contain men of recognized ability who have a thorough knowledge of the important details of the industry, particularly costs, specifications and volume of production. Where the industry is widely scattered and different problems exist in different sections, it is important to have the different sections of the country represented, but effort should be made to appoint a committee which can be readily assembled for committee meetings.

D—Sub-committees of the important branches of the industry should be appointed to co-operate with the war service committee wherever possible.

---

### Work of the Factory Metallurgist

Where tools are of complicated shape, special apparatus is required for the quenching operation and when necessary, such apparatus should be available for the hardener's use. Partial hardening to avoid cracking or warping is often required, and lack of proper equipment frequently taxes the ingenuity of even the most experienced hardener. Streams for interior hardening and sprays for surface hardening should be available, and, where much of the work is of the same kind, fixtures for quenching will be found of value. It is almost impossible to harden interior surfaces or hollows in the regular manner, a statement to which many will bear witness. Steam pockets are almost sure to form, and in some cases the hardening effect will be so irregular that fracture may occur through the excessive strains produced. A heavy stream of water forced against the surface will usually give excellent results. Special methods of quenching will often allow proper hardening. Deep drawing dies, swaging dies and rivet sets are examples of tools requiring special handling.

The treatment of high speed steel is an art in itself. On account of the high temperature required, 2,100 deg. F. or more, and the necessity for judging this by eye in continuous working, considerable attention must be paid to all the essential details. For pieces of any size pre-heating is essential to avoid scaling or cracking due to exposure to the high temperature for any length of time. Various quenching mediums are used, oil most commonly. Where the tool is of complicated design, susceptible to cracking, molten lead at a temperature of about 800 deg. F. will give excellent results. The final heating should be carried out rapidly and all the fuel which can be properly burned, supplied to the furnace to insure this. For special tools, as, for instance, twist drills, special furnaces must be provided.

After the hardening operation, tools, especially of carbon steel, are given a drawing treatment at a low temperature in order to remove strains. This operation is of value with tool steel, and in some cases with carbonized work of complicated design or with sharp corners liable to snall after hardening. This operation will by no means

correct the results of improper handling in previous operations, and for carbonized low carbon steel will usually have little or no value, although it is frequently mentioned as a cure-all for troubles.—Extract of paper read before S. A. E. by R. H. Sperry.

---

### Australian Prohibition on Automobile Bodies

An article published in a Melbourne paper throws additional light on the policy of the Australian government in regard to the recent prohibition of the importation of automobile bodies.

Representatives of importing concerns had waited upon the Minister of Customs to protest against the enforcement of the prohibition, thus causing some fears on the part of the manufacturing interests that the restriction might be withdrawn. Deputations representing manufacturers of motor car bodies and allied interests in the state of Victoria accordingly appeared before the minister to present the claims of the home producers. The trades represented were motor body builders, leather workers, sheet metal workers, metal parts plating, glass beveling, varnish, and paints. The manufacturers gave assurances that there would be no difficulty in supplying local requirements of motor bodies, one representative stating that his firm alone was prepared to turn out 180 motor bodies by January, 1918. Australian-made bodies, it was contended, were quite as good as imported bodies, and in some cases outlasted them. Scarcity of sheet metal supplies was mentioned, but supplies on the way and new production by Australian firms were expected to remedy the shortage.

In his reply to the deputation the minister stated that the government expected to maintain its original position in regard to the prohibition. A petition to that same effect had already been received from the New South Wales body builders. The minister expressed confidence in the ability of Australian manufacturers to equal the standard of imported goods and stated that no alarm need be felt because of the petitions of importing interests. The government would be guided by the actions of the home manufacturers, and if they went to the expense of putting in extra plant the government did not propose to destroy the value of their enterprise. The matter would be regarded, in the minister's words, "not only from a financial and commercial point of view, but also from the Australian viewpoint."

---

### Cutler Chief of Foreign Commerce Bureau

The appointment of Burwell S. Cutler, of Buffalo, as chief of the Bureau of Foreign and Domestic Commerce, Department of Commerce, was confirmed by the Senate. Mr. Cutler, who is well known in manufacturing circles in western New York, came into the bureau six months ago at a nominal salary to assist in putting the organization on a thoroughly business basis. He was made first assistant chief, but since the resignation of Dr. E. E. Pratt has been acting chief.

Mr. Cutler was born in Buffalo and finished his scholastic education at Lake Forest University and Harvard. For 15 years he has been president of an important Buffalo manufacturing concern and has been identified in an official capacity with numerous business houses and civic organizations throughout New York state.

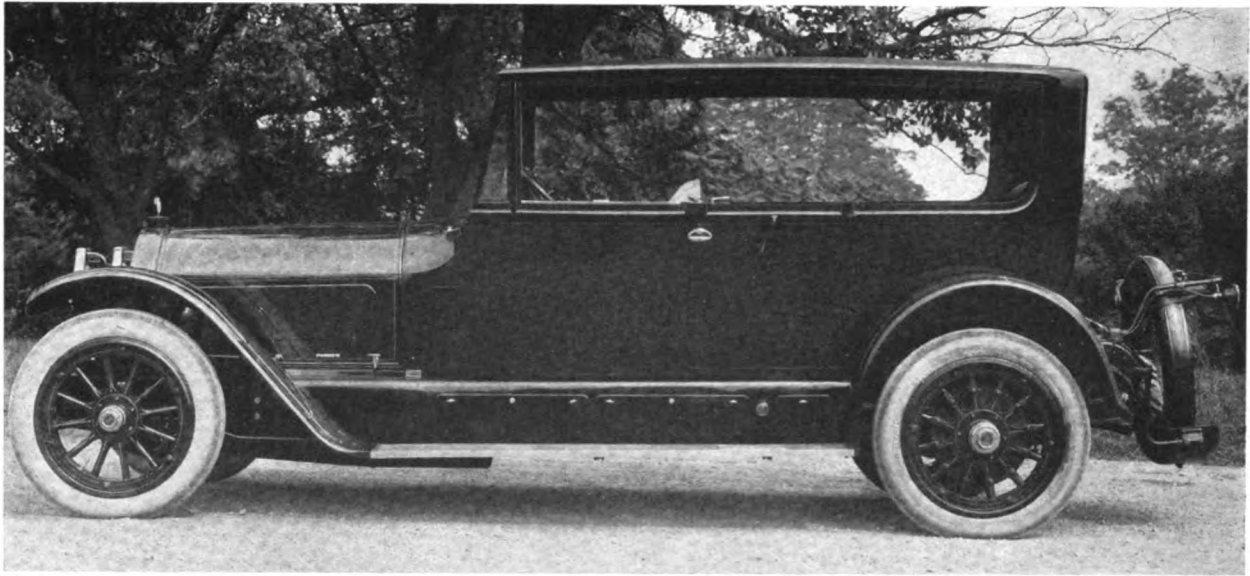
**TOURING SEDAN**

Body by The Holbrook Co., New York. Mounted on Locomobile chassis

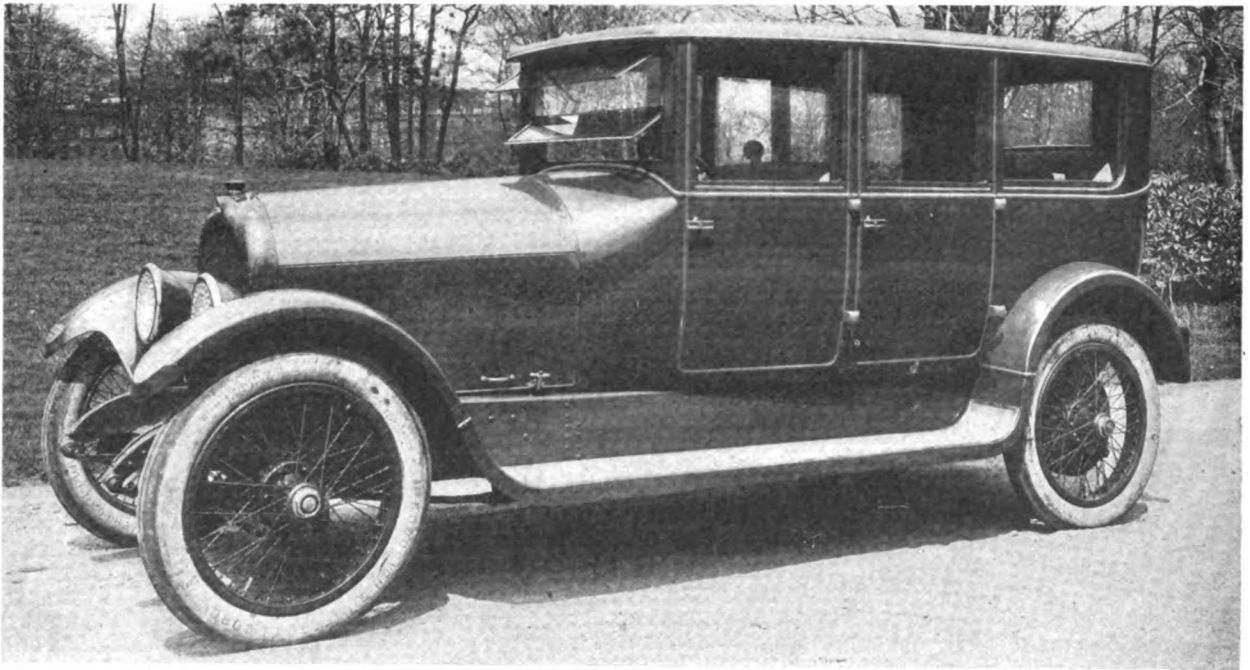
**CONVERTIBLE LIMOUSINE**

Body by Blue Ribbon Body Co., Bridgeport, Conn. Mounted on Marmon chassis

Is of the four-door permanent-roof type and can be instantly converted into a berline, limousine, sedan or touring body. Detachable division window back of front seat can be removed, converting the body into a sedan type. Pillars are also removable and pockets are provided to care for the side windows, therefore easily converted into a touring body. The door windows are operated by regulators, if necessary, or the windows can be removed entirely and carried in a pocket under rear seat. The special design of construction makes it practically rattle proof.

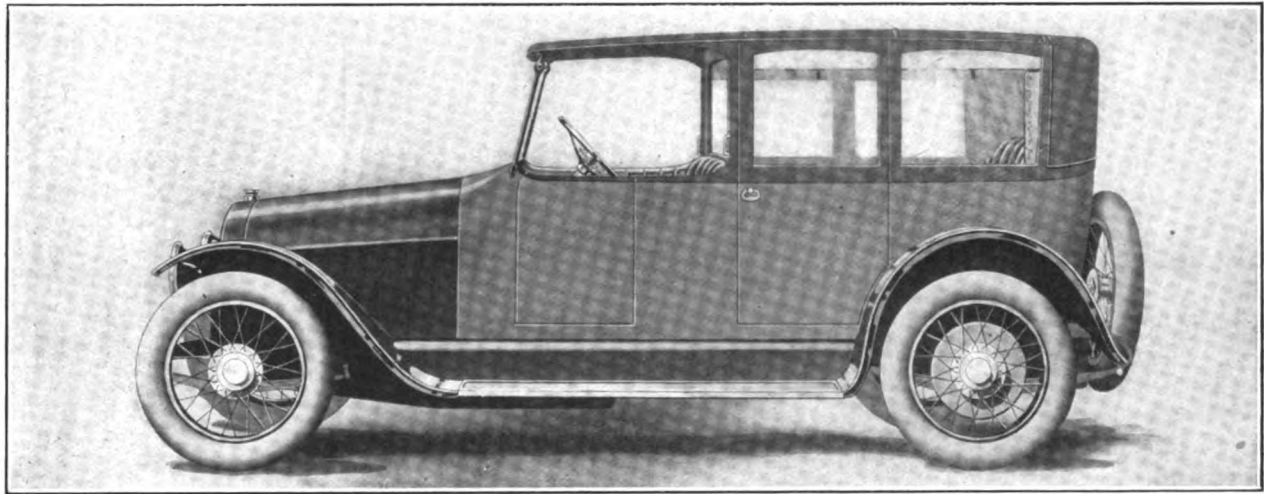

**LANDAULETTE**

Built by Blue Ribbon Body Co., Bridgeport, Conn.

Combines all of the important features in the standard landaulette with additional limousine type features; elimination of side joints, collapsible features, etc., etc.

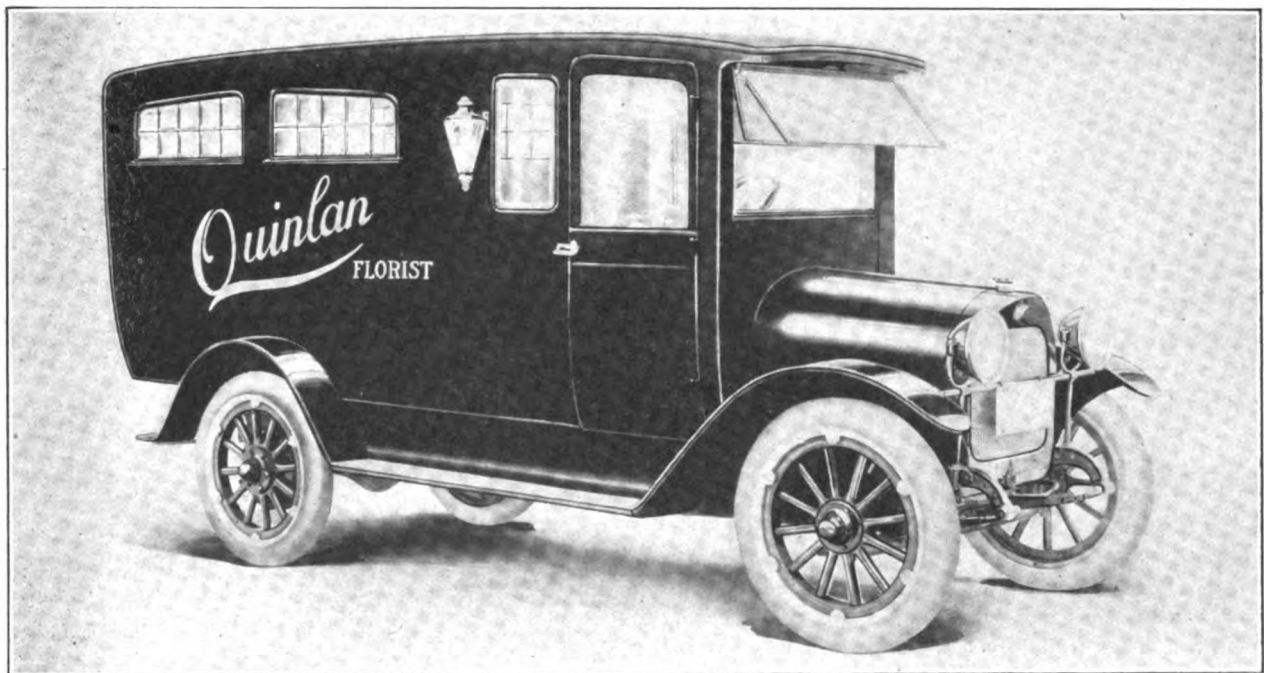

**FLORIST'S CAR**

Built by August Schubert Wagon Co., Oneida, N. Y.

## Present Demand and Standardized Production

A small manufacturer of lathes, shortly after the beginning of the war, decided that the demand for his product was such that he could sell all he could make of one size and style. He had been connected with the automobile industry and had learned its lesson of specialization. So he built 1,200 lathes all three-stop cone, double back-gear, of not only the same swing, but also the same length. The length of bed was such as to load his planers most economically, and the other details were figured out in the same way. At the same time he secured another shop and started building 800 lathes, slightly larger, identical throughout. Regardless of the nature of the request, he quoted on these two sizes of lathes and refused to change anything from the length to the smallest item of equipment. It took nerve, but it worked. His production jumped without an effort over 25 per cent, and the quality of the product was uniformly better.

There is, in this manufacturer's success, a lesson that is of especial importance just now when it is only a question of meeting the demand. It may not be that every plant can afford to cut down its line to one product. It may be necessary for a plant to hold its prestige in different lines, pending the return of normal conditions, and its equipment may not be adapted for so limited a product; but it will pay every manufacturer to study the lines he is producing and find which he can manufacture most profitably. He should see if there is enough business in those lines to keep his plant busy under normal conditions and concentrate on them now, when the demand will keep him busy. Then he can plan his marketing and improvements in his product, and study its manufacture and standardization, so that when business is again normal he will be able to secure enough of the line in which he specialized to keep his factory humming. Such a concentration will result in a simplifying of the machine; and interior arrangement of his factory, with a corresponding reduction in the work of planning, routing and cost keeping. The greater efficiency that is bound to follow will do much to enable the manufacturer to maintain his production against the decreasing man supply.—D. M. Perrill, in Machinery

## School for Auto Draftsmen Has Successful Year

The year just closed by the Technical School for Automobile Draftsmen and Mechanics at Mechanics' Institute, 20 W. 44th street, New York City, was one of the best since that institution was established in 1880, according to the annual report of Instructor Andrew F. Johnson.

There were eight day and 56 evening students. Three of the day students lived in New York and the balance came from Chicago, Detroit, Columbus, O., and Schenectady, N. Y. The evening students all claimed Greater New York as their home, but some of them came from other points and secured employment in order to be able to attend school. Thirty-three of these men were body makers, nine were general woodworkers, eight were draftsmen, with two foremen, one timekeeper, one office man, one clerk, and one superintendent.

The day and evening classes closed for the season on April 11, 1917. There were 12 graduates, two from the day class and ten from the evening class. The average age

of the graduates was nearly 27 years. The evening classes averaged an attendance of 36.

The annual exhibition of drawings made during the season was held on April 17 and was well attended.

The correspondence department of the school is kept open the year round.

The school is becoming so well and favorably known in the trade that its graduates are sought for, and in recent years are employed as soon as the school season is done, and in some cases before it is done.

Graduates are holding the best places in the body building part of the trade and are looked on as leaders in style and construction and they receive the highest salaries.

These men are equally successful in the custom shops where only the highest grade of work is accepted and in large factories where the greatest efficiency in production is required.

This school was opened because of a real need in the trade for such a school. It has met the need and measured up to every requirement, adapting itself to the changed conditions in the vehicle industry, and is more useful now than ever before. The school has been operated at a very small cost in money, and has done and is doing a great work. One reason for this is the fact that the school has from the beginning had the enthusiastic support of the best men in the vehicle trade. They have been proud to serve on its committees and have given freely of their time in directing its operations.

## Tests of Wagon Drafts

An experiment to determine the amount of power necessary to move loads over various kinds of road surfaces was recently completed in California. A wagon with 4 in. tires, drawn by two 1,600 lb. draft horses and loaded with sacks of rice, the load consisting of three tons, was driven over different road surfaces at the rate of about 2.4 miles per hour. Conditions for each test were as equal as it was possible to make them. Measurements of power were made by Prof. J. B. Davidson, of the University of California, with an instrument invented by himself. The table is given below:

	Total draft 3-ton load, lbs.
Concrete road .....	90
Concrete road, $\frac{3}{8}$ in. oil top.....	155
Macadam, good condition.....	193
Oil macadam .....	218
Gravel road, good.....	225
"Topeka," $1\frac{1}{2}$ in. surface.....	285
Earth road; dust $\frac{3}{4}$ to 2 in.....	298
Earth road, mud.....	654
Gravel road, loose.....	789

## Stearns Retires From Murphy Varnish Co.

Melvin H. Stearns, treasurer of the Murphy Varnish Co., Newark, N. J., has retired from active business. Mr. Stearns was for a number of years the manager of the St. Louis branch of this varnish house, but for the past ten years has been treasurer of the corporation, with headquarters at Newark. Mr. Stearns was connected with the Murphy Varnish Co. for 37 years, and with the possible exception of a 60-day trip to Europe and the usual two weeks' summer vacation, he has been actively engaged in furthering the interests of the Murphy company. As Mr. Stearns' health has not been of the best for some time past, he plans to spend several months in California.

# How Factory Lay-Outs Aid Production

## Problem of Transporting Materials and Products Through Plant to Reduce Production Costs

[Continued from September issue]

By Edward K. Hammond \*

**M**OTOR-DRIVEN trucks, provided with their own power plant in the form of an electric storage battery and motor, are now being used in many industrial plants in the United States. Trucks of this type naturally cost considerably more than any of the trucks which are driven by manual labor, and the only justification for in-

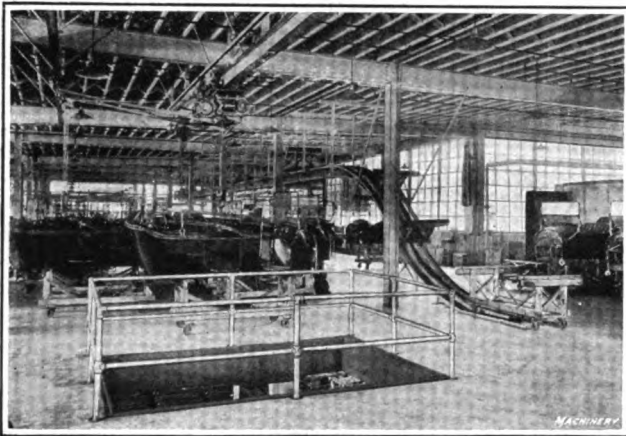

Fig. 20—Economy of space is a point of vital importance in plants handling a large volume of product. This illustration shows how automobile bodies are handled in the Willlys-Overland Co.'s plant in Toledo, O. The assembled bodies are picked up and carried away on a trolley hoist, and empty trucks are carried back to the beginning of the assembling line on the overhead track.

vesting in equipment where the first cost is higher is if conditions of operation are such that a greater amount of service might be obtained from motor-driven trucks. It is difficult to make statements to cover general conditions, but in the present case it may be stated that the particular field of usefulness of motor-driven trucks is where the length of haul is sufficiently great so that a material saving of time and labor may be obtained through the increased speed.

The driver stands erect on a platform at the end of the truck, with his hands on the controller and steering levers, respectively, and one foot on the brake pedal. Simplicity of operation does away with the necessity of hiring high-priced operators for these trucks. Where motor-driven trucks can be kept busy, the General Vehicle Co., of Long Island City, N. Y., claims that with hauls ranging from 200 to 800 ft. each truck will take the place of from four to six men. There are many classes of work where better results will be obtained with hand trucks; but for those classes of service for which motor-driven trucks are adapted, they give highly satisfactory results.

\* Associate editor of Machinery.

This article and illustrations reproduced through the courtesy of Machinery.

Motor-driven trucks may be furnished with flanged wheels for operation on rails, or with rubber-tired wheels to travel on the floor. Signal systems of various kinds may be used—such as electric lamps or flags—to show when aisles are clear for the passage of trucks, or when one truck is likely to meet another before reaching the opposite end of the aisle. Electric trucks are built in many designs to meet the requirements of different classes of work. Elevating trucks are made for use in connection with platforms, boxes, etc., and plain trucks are made for carrying loads directly. In addition, there are the so-called tractors designed for pulling one or more cars on which the load is piled.

### Progressive Machining Operations

Where machining operations to be performed on a given part are of such a nature that a battery of planers, milling machines, drill presses, boring machines, etc., is required to finish a piece, it is of the utmost importance to have these machines so grouped that the work passes continuously from machine to machine without delays. In many well organized factories the equipment has been so arranged that conveyors, trucks or some other form of device can be used to carry the work from machine to ma-



Fig. 21—The Willlys-Overland Co. has a motor storage department on the opposite side of a roadway from the building containing the motor assembling department. Motors are carried over into this storage department on an apron-type conveyor which runs through a tunnel under the road. This conveyor was built and installed by the Link-Belt Co., of Chicago, Ill.

chine with the least amount of time and labor.

An example of this kind is seen in the milling operations on aluminum crank cases in the plant of the Buick Motor Co., Flint, Mich. The first four milling operations are performed on Ingersoll planer-type milling machines, which provide for handling five upper and five lower halves



of the crank cases at a time. In operation, the table is run forward under the crossrail, and castings placed ready on the floor are dropped into position in the milling machine fixtures without any attempt to tighten the clamps on the fixtures. Then as the table starts to feed back, the operator starts with the fixtures nearest the crossrail and tightens up all bolts so that the work is secured for machining. After all the work has been secured he goes to

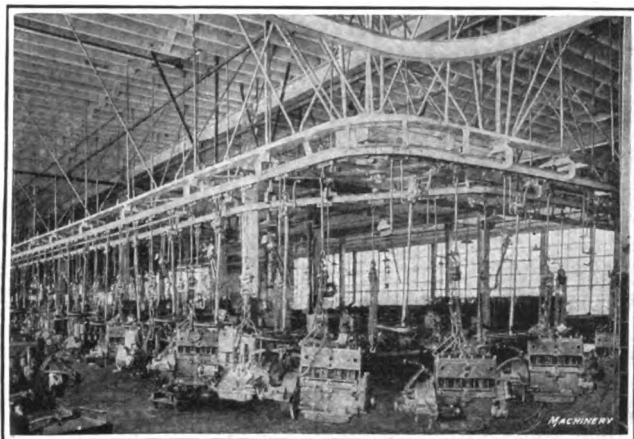

Fig. 22—In large plants, such as that of the Willys-Overland Co., a visitor is bound to be impressed by the variety of equipments employed for handling raw materials and product. For instance, the preceding illustration shows an apron-type conveyor for carrying assembled motors, and in this view the same class of work is being done by a trolley system installed by the Link-Belt Co.

a position back of the crossrail and starts taking out the milled cases, which are swung over onto gravity carriers and rolled down to a position ready to go on the next Ingersoll milling machine. In this connection it is important to note that the gravity carriers are made the same height as the milling machine tables so that the work can be transferred from the carrier to the table and vice versa with the minimum effort.

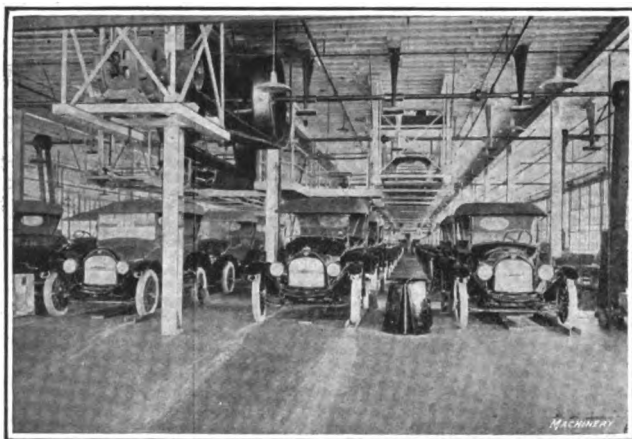

Fig. 23—Progressive assembly of automobiles has been developed to a high degree by engineers of the Willys-Overland Co. Four assembling tracks are provided in the factory, down which cars are run, and conveyors running at right angles to these tracks carry all the different parts to the assemblers. This system has been brought to a high degree of perfection and work is handled very rapidly

A more highly developed method of progressive machining consists of having tracks laid between different machines on which trucks run that support jigs and fixtures for carrying the work. Fig. 12, in the first instalment, shows a view in the plant of the Packard Motor Car Co., Detroit, Mich., where crank cases are being drilled. There are 200 holes to be drilled in these cases and the complete

drilling operation is finished in 42 minutes; the actual drilling time is  $38\frac{1}{2}$  minutes and  $3\frac{1}{2}$  minutes are allowed for setting up and removing work from the jig. The machine tool equipment consists of seven Baush multiple-spindle drilling machines with various numbers of spindles and different types of heads, and one radial drilling machine. The jigs are arranged so that they can be pivoted to bring different surfaces of the work into the operating

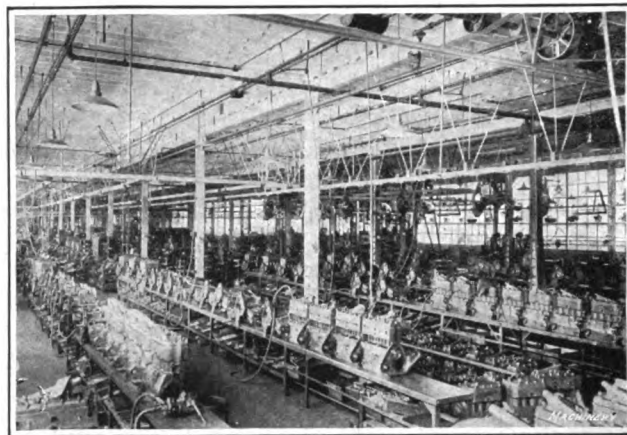

Fig. 24—Overhead conveyors are used in the motor assembling department of the Willys-Overland Co., Toledo, O., for carrying the larger parts of the motors to the assembling benches. Small parts are held in New Britain tote boxes underneath the benches, where they are within convenient reach of the operator

position. Index pins enter hardened steel bushings in the jigs, locating them accurately for each successive operation, and clamps are provided which secure the jig trucks in place on the tracks. Handled in this way, a high rate of production may be obtained, because the workman is relieved of all physical strain in lifting work on and off machines, it being merely required for him to set the work up in the jig at the beginning of the row and remove it when the job is finished. One workman follows a single



Fig. 25—In the Ford Motor Co.'s plant every possible saving is effected in production. In assembling motors, as fast as one man finishes his task he pushes the motor along to his companion and receives a new motor from the man on the other side. This is another example of the progressive method of assembling

casting right down the line, performing all the machining operations required on it.

For boring, milling and other operations where the fixtures are of such a type that it would not be feasible to use a single fixture for a number of operations, a somewhat similar idea may be employed. Instead of having the work and fixture taken from machine to machine on tracks, a roller type conveyor is run parallel to the line



of machines, with switches branching off to individual machines, as was illustrated in Fig. 18 in the September instalment. With an equipment of this kind the operator can push a heavy casting along on the conveyor and run it in on the switch to a given machine. The conveyor and the machine table are the same height, so that the operator merely swings the work over from the conveyor and puts it in position in the fixture for machining. When the operation has been completed the casting is put back on the switch and run up to the main line, upon which it is carried to the switch leading to the next machine. Where this method has been adopted it has been found the means of saving a great deal of time in the performance of machining operations.

**Laying Out Gravity Carriers**

As the name implies, the pitch of a gravity carrier is relied upon to enable the force of gravity to run the load

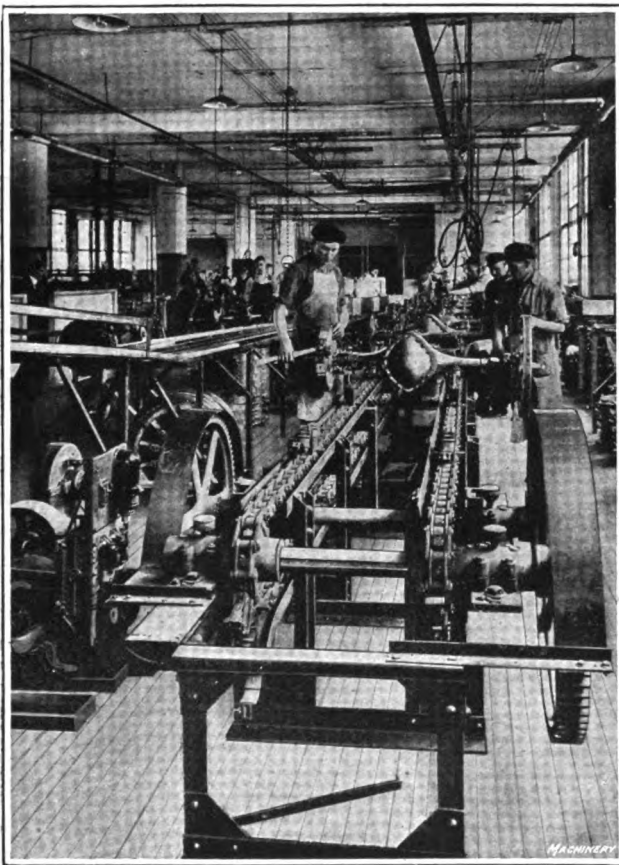

Fig. 26—The Palmer-Bee Co., of Detroit, Mich., makes a specialty of designing and installing time and labor-saving equipments for handling material in course of manufacture. This illustration shows an outfit installed by this company for assembling automobile transmissions. Two strands of endless chain carry brackets which support the work at each end

along the conveyor without the application of power from an external source. In designing this type of equipment it is the practice of the Mathews Gravity Carrier Co., Elmwood City, Pa., to make the pitch of conveyors from 2 to 8 per cent, but most of the conveyor systems installed by this company have a pitch of 4 per cent. In the construction of conveyor systems of this type there is a good deal of variation in the lay-out, according to the nature of the work to be carried. Packages with smooth, flat bottoms may be run on these carriers without guard rails, but where the load is irregular in shape some form of guard rail is necessary.

Various expedients are adopted to keep the load running on these conveyors. The most obvious way is to place a guard rail at each side so that it is impossible for the load to run off. A simple method and one that is highly satisfactory where the packages or parts to be carried are of fairly regular shape, is to have a small flange at both ends of each roller. This flange rotates with the roller so that there is no loss of efficiency through the retarding



Fig. 27—In this case, the magnetic generator unit of the motor is carried on an endless belt conveyor, and men with power-driven wrenches are screwing up the nuts. Attention is called to the large number of men at work; this is typical of the intensive production methods in the Ford Motor Co.'s shops

action of a fixed guard rail, and still it is effective in preventing work from running off. A still simpler method and one that is effective in cases where the work has a smooth surface to run on is to make the conveyor with two sets of rollers. These rollers are arranged in pairs, with the rollers of each pair inclined at a slight angle, so that the two rollers have a form somewhat similar to the letter V (the angle is much less acute) with the apex

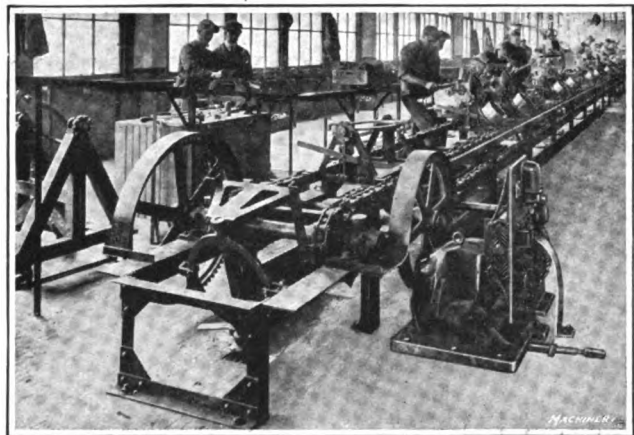

Fig. 28—Formerly the Packard Motor Car Co. assembled clutch units on stands that were distributed over the floor of the clutch assembling department. The Palmer-Bee Co. suggested that the progressive method of assembly be employed in handling them, so a conveyor system was installed, which carries stands similar to those formerly employed

pointing in the opposite direction to that in which the load is to travel. The effect of this inclined double roller construction is to keep the load on the conveyor, the tendency of each of the inclined rollers being to force the load toward the center. For handling pig iron and other irregular shaped pieces of this kind the only way to be sure of keeping the load on the conveyor is to use a guard rail at each side.

### Use of Revolvator

A machine known as a "revolvator" is built by the New York Revolving Portable Elevator Co., Jersey City, N. J. This is a portable elevator mounted on a revolving base so that the elevator platform may be faced in any direction to receive or discharge a load, as the case may be; ball bearings in the revolving base enable the elevator to be

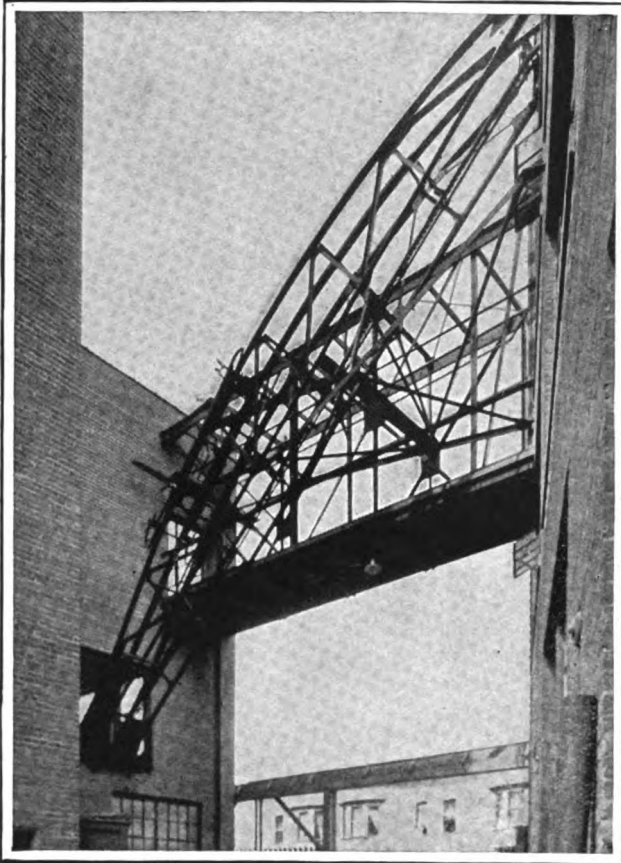

Fig. 29—In the Studebaker Corporation's factory in Detroit it is necessary to transfer automobile frames from one building to a floor two stories higher up in an adjacent building. For this purpose a conveyor system was installed by the Palmer-Bee Co. It consists of a structural steel frame with rails, over which the automobile frames are pulled by an endless chain conveyor

easily swiveled when carrying its maximum load. This type of equipment is used for a variety of different classes of service in industrial plants, but a typical case is where it is desired to raise or lower a load and turn the elevator in the direction in which the load is to be deposited. For instance, suppose that a stock room is arranged with aisles running over to the wall and the necessity for economizing in the use of space makes it necessary to stack material up almost to the ceiling. Here the revolvator may be used to excellent advantage, as the material is brought on elevating trucks or in any other convenient way and deposited on the platform of the revolvator. The load is then raised to the desired height and the platform turned so that the load may be run off at either side of the aisle onto the top of the material already stacked.

A similar use is where sheet metal and other material is being stacked in racks; the revolvator carries the load down an aisle, and when it reaches its destination the platform is raised and turned through one-quarter revolution to allow the load to be slid off onto the racks. Another similar example is where heavy dies for use on power hammers and presses are kept in storage racks. These dies are so heavy that they are hard to handle, and

work of this kind can be done conveniently by pulling them out on the platform of the portable elevator, which is then lowered to a convenient height. The entire elevator then serves as a truck on which the die is pulled to the machine on which it is to be used. Here the platform of the elevator is adjusted to bring it to the same height as the bed of the machine, so that the die may be easily slid off the elevator platform into place on the machine.

(Concluded in November issue)

### The Liberty Motor

The Liberty motor, a standardized, minimum weight, high-powered aviation engine, work on which was begun at the Bureau of Standards early in June, is pronounced a complete success in an official statement promulgated by the Secretary of War. It is the lightest engine per horse power ever constructed for airplanes, and will be the main reliance of the United States in the rapid production in large numbers of high-powered battle planes for service in the war.

The new motor represents the best features of all the airship engines heretofore produced in this or any other country. Light weight and great power having been achieved early in the designing of this motor, perfect standardization was the next object aimed at. Cylinders, pistons and every other part of the motor have been most accurately standardized so that they can be produced rapidly and economically by a great many factories operating under government contracts. They may be as rapidly assembled either by these plants or a central assembling plant.

The standardization of parts materially simplifies the problem of repair and maintenance. Spare parts will be promptly available at all times. Even the cylinders are designed separately. It is possible to build the new engine with four models ranging from 4 to 12 cylinders and the standardization plan makes possible an 8-cylinder or a 12-cylinder model by merely assembling the necessary cylinders, pistons, valves, cam shafts, etc. So carefully has the scheme of standardization been worked out that parts of wrecked 8-cylinder or 12-cylinder engines will be interchangeable and a new engine may be readily assembled from parts of machines that have been put out of action. This feature will make the matter of repairs back of the lines comparatively simple.

More than a score of engineers pooled their skill and many important trade secrets in the development of this design, working with the encouragement of the Aircraft Production Board, of the War Department and of the Bureau of Standards.

### Final Settlement of Michigan Buggy

The Michigan Buggy Co., Kalamazoo, Mich., bankruptcy is now in the final settlement stage with the final payment of 1 48/100 per cent made by the trustee in bankruptcy. This makes a total distribution to unsecured creditors of 23 per cent. The total receipts of the trustee were \$845,736 and the unsecured claims were \$2,560,231. The trustee continued the manufacture of automobiles until all the material was consumed.

The American Chain Co., Bridgeport, Conn., is said to be planning for the establishment of a branch manufacturing plant near Norfolk, Va.

**Body Design for Omnibus**

The design of the body shown in the illustrations is to be used as a passenger omnibus. The seats run lengthwise of the body, and each seat will accommodate six passengers comfortably, making a seating capacity for 12 passengers and the driver. Entrance as provided is at the rear of the body. The one door at the side of the driver's cab is for the driver only. The body is entirely closed, protecting both driver and passengers from all weather conditions. The seats can be made of wood

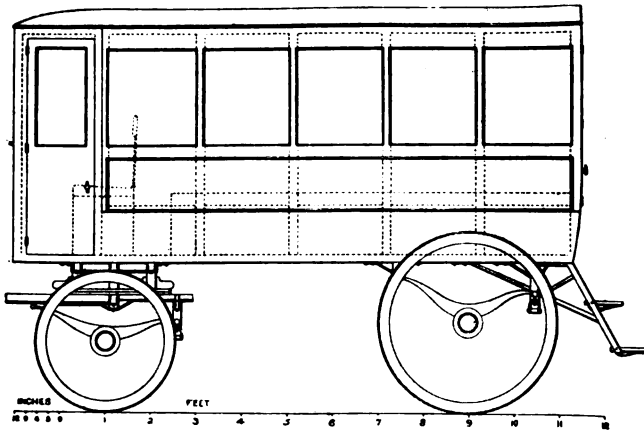

Fig. 1

seating or upholstered. The driver's seat is made small, giving easy access to the rear of the vehicle when necessary, which is clearly shown in Fig. 2. The driver's seat has a lazy back which can be folded down out of the way if necessary for passengers to leave by the side door in an emergency. The length of the body is 12 ft. 6 in. The width is 4 ft. 9 in. across the top and 3 ft. 5 in. at the bottom. The length of the overhang side is 10 ft. 8 in. Height of overhang side is 4 ft. 6 in. The total height of body is 5 ft. 7 in. There are ten windows on the two sides, each measuring 2 ft. by 2 ft. 2 in. The glass frames are made of the channel pattern, being of brass or aluminum and mitered at the corners. This frame gives more light and looks better than wooden frames, and is stronger. The driver's door at the side of the body is 1 ft. 6 in. by

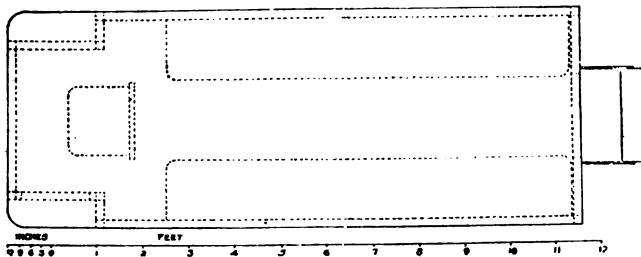

Fig. 2

4 ft. 9 in., with a window 14 x 26 in. The window in front of the driver's cab is 2 ft. 9 in. by 2 ft. 2 in. There is also an opening for the reins below the window 8 x 1½ in. The rear door is 1 ft. 10 in. by 4 ft. 9 in., which has a window 18 in. by 2 ft. 2 in. There are two rear windows, 1 ft. by 26 in. The two steps at the rear are 9 in. by 2 ft., the bottom step being 16 in. from the ground. The passengers' seats are 9 ft. long, 16 in. wide, and from the top of the seat to the floor is 16 in. The driver's seat is 18 x 18 in. and 18 in. high. Blankets, etc., can be stored under the driver's seat. There are 12 roof bows 1 x 1½ in., equally

spaced. The timber is hard wood, only the two frame sills being 1½ x 2¾ in. Two lower body sills 1½ x 4 in. Two end cross bars 2¼ x 2¾ in. Five inside cross bars 1½ x 2¾ in. Two side boards 7/8 x 12 in. Two upper body sills 1½ x 6 in. Four bottom boards ¾ x 10 in. Eight uprights for side boards 7/8 x 1½ in. Two rear corner posts 2¾ x 3½. Two front corner posts 2¾ x 3½ in. Two side rails 1½ x 3½ in. Two side top rails 1½ x 3½

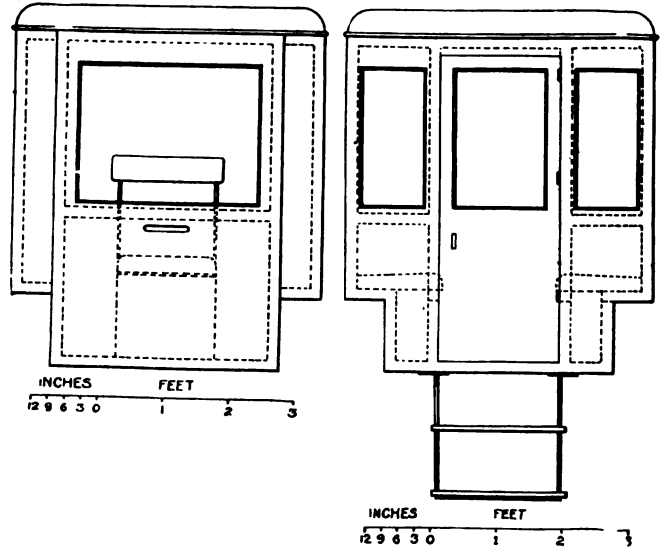

Fig. 3

Fig. 4

in. One upper front cross rail 1½ x 3½ in. Two rear door pillars ½ x 1½ in. Fig. 1 is a side view, Fig. 2 is a plan view, also showing location of seats, etc. Fig. 3 is a front view, while Fig. 4 is a rear view. These drawings are scale drawings so that any measurement desired can be easily obtained.—Blacksmith and Wheelwright.

**All Ansted Properties in New Lexington Co.**

The entire group of factories belonging to the Ansted interests at Connersville, Ind., were brought into one financial family in the recent formation of the Lexington Motor Co., the successor to the Lexington-Howard Co., which was also controlled by the Ansteds.

Ten separate factories are involved in the operation, one building bodies, one tops, another springs, another lamps, another axles.

The new company is capitalized at \$1,800,000, being divided in equal amounts of common, first and second preferred stocks. No change of management is contemplated. Frank B. Ansted is president, succeeding his father, the late Edward W. Ansted; and Arthur A. Ansted, a brother, has been appointed a director. Production increases are foreshadowed in building operations now under way.

**Barrie Carriage Increases Car Production**

The Barrie (Ont.) Carriage Co., Ltd., has entered upon its second year in the car business and, according to Manager J. B. Barr, the volume of production for 1918 will be 1,200 cars. It is also continuing with the manufacture of horse-drawn vehicles. The car made by this concern is known as the Bell, and various parts are imported from the United States. The company has been appointing distributors and agents throughout Canada from Halifax to Calgary.

# Standard Ammunition Body

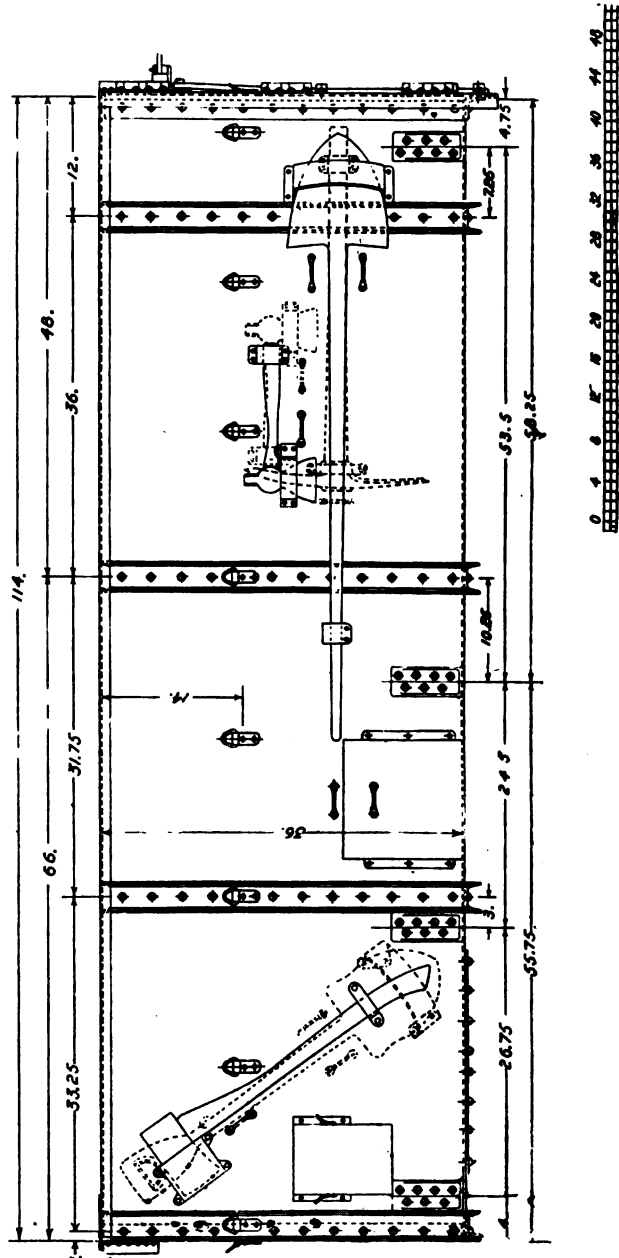
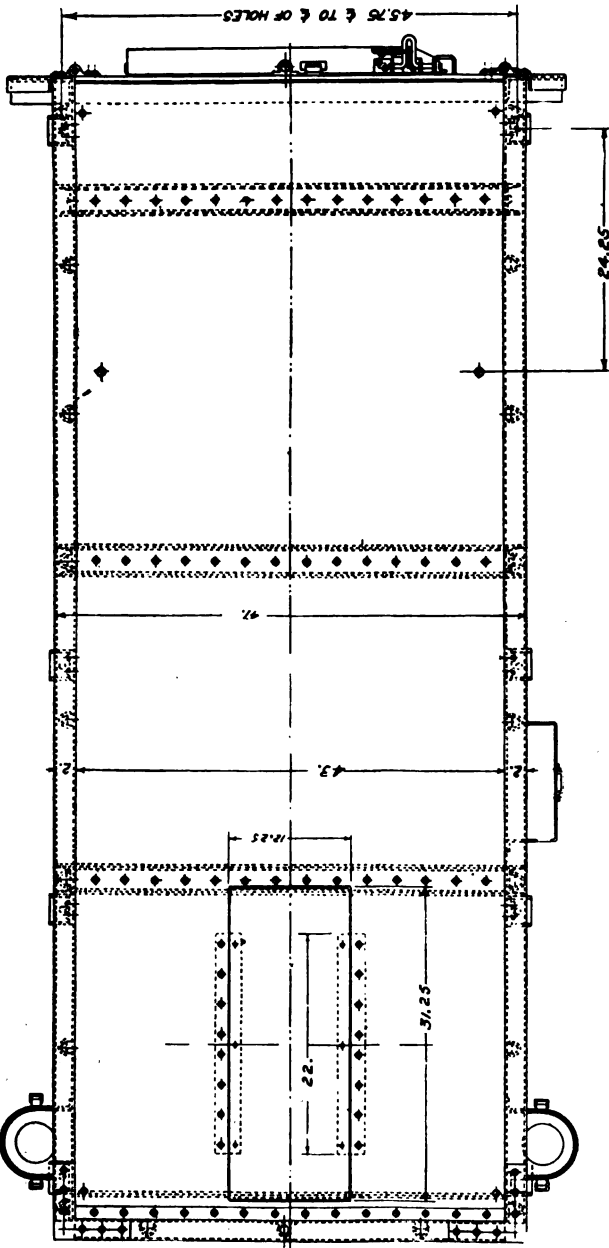
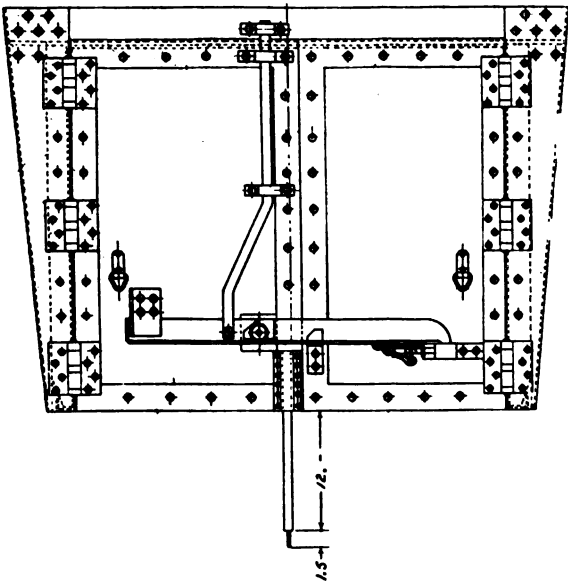

## Specifications for Standard U. S. Ammunition Body

[Reproduction of blue print on opposite page]

**Quality of Materials**—Except it be otherwise specified, all materials are to be the best of their respective kinds, and all labor is to be done in the most thorough and workmanlike manner. In all cases where an article is mentioned in these specifications in connection with the words "best quality," "best make," "proper," or "suitable,"

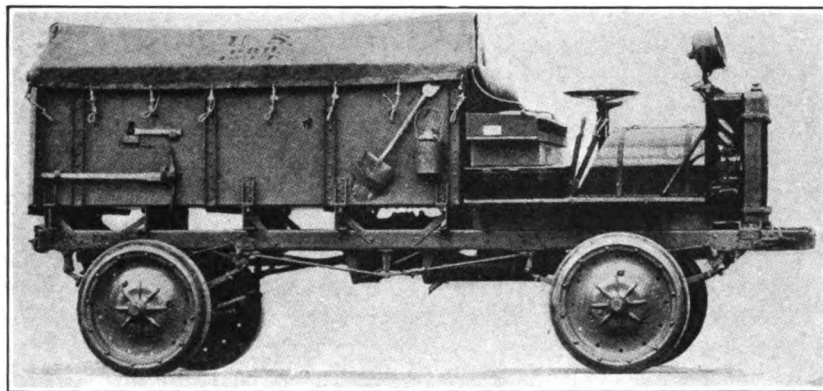

Side View Standard Ammunition Body

the Ordnance Department or its authorized representative shall decide what is best and most suitable to use.

2. **Award of Contract**—The bodies herein specified are to be used in the field service of the Ordnance Department, and in the selection of bodies and award of contract, the quality of material, design, workmanship, and suitability for use in field service will be given due weight in determining which proposal shall be accepted. Attention is called to Instruction to Bidders, Form No. 434.

3. **Employment of Convict Labor**—In the performance of work herein specified the contractor shall not, directly or indirectly, employ any person undergoing sentence of imprisonment at hard labor which have been imposed by a court of any state, territory or municipality having jurisdiction, nor permit such employment by any person furnishing labor or material to said contractor in fulfillment of this agreement.

4. **Patents**—The contractor shall for all time secure to the government the free and undisputed right to use any and all patented articles used in the work, and shall defend at his own expense any and all suits for infringement of any patent or patents, and in case of adverse claims under patents, the contractor shall pay all awards.

### Description

5. **General Requirements**—The bodies shall be complete in every respect and ready for installation on the chassis. Bodies shall be so constructed as to permit of their installation on any chassis frame irrespective of the width or height of frame, and at the same time permit of ready access to the transmission and rear axle, and to give a proper clearance between the rear wheels and truck body when the truck is fully loaded. The body shall be con-

structed in accordance with details shown on drawings Nos. Cl. 31—Div. 20, Fig. 4.

6. **Material**—The entire body, sides, end and rear doors are to be made of No. 10 flange steel commercial or best quality No. 10, hot rolled, smooth finish, medium temper steel of 0.15 carbon.

7. All iron or steel used in construction of bodies must be free from rust, corrosion or pitting, and must not be bent or warped. Where steel castings are used they must be thoroughly annealed. The special body parts shown on the drawings, including fastening brackets of body to chassis, hinges and hinge butts must be made of forged steel.

8. The body shall be reinforced at proper intervals as shown on drawing with 3 in. 4 lb. standard steel channels thoroughly fastened to the body with hot 7/16 in. rivets. All holes in the body shall be 1/32 in. larger in diameter than rivets, and will be reamed after punching.

9. All parts of the body, where possible, must be connected by 7/16 in. hot rivets.

10. All steel floor plates, body side and top angles or channel, and all other steel strips or sections shall be in continuous lengths. No piecing of these parts will

be permitted, except it is allowable to make body sides and bottom of two pieces welded along the center of bottom.

11. Brackets for securing various implements to body will be furnished by the United States and installed in such locations as shown by drawing and will conform to drawing, Nos. Class 31—Div. 20—drg. 4.

### Covers

12. **Material**—The body covers must be best quality No. 6 standard cotton duck, made from American cotton, woven in a workmanlike manner and free from imperfections, thoroughly brushed to remove motes or other foreign

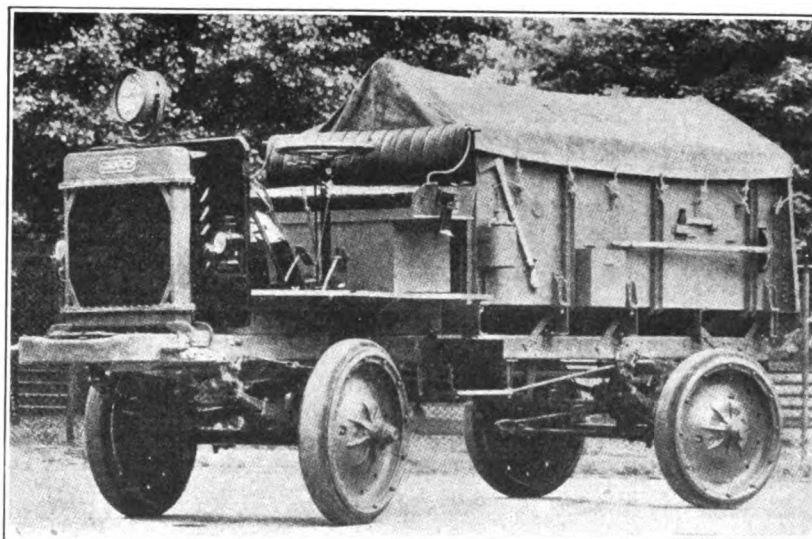

Perspective View Standard Ammunition Body

substances, and must be waterproofed. No pieced lengths will be allowed.

13. The covers must have grommets worked over 5/8 in. galvanized iron rings. Ropes to be 3/8 in. of best quality manila. All side ropes to be neatly spliced into grommets, all face ends to be well whipped with well waxed thread.

14. Lettering—All covers must be stenciled in two places with "U. S." with 6 in. black doric letters, and "ORD." and "DEPT." with 4 in. black doric letters, the whole to be arranged symmetrically, as shown in drawing 38—9—14.

15. General Provisions—The covers must be made in accordance with the dimensions shown on drawings. All work to be done in the best workmanlike manner. Covers to be subject to the usual inspection.

16. Painting—The bodies must be painted all over, as per drawing 27—26—1 (prints of which specifications will be sent on request), each coat of paint being permitted to thoroughly dry before applying the succeeding coat.

17. All iron and steel must be given one good coat of lead and oil, and permitted to thoroughly dry, before assembling.

### New Army Truck a Wonder

The first heavy-duty war truck, which the Quartermaster Department has been designing since the first of August, was assembled and started running at Lima, O., October 8. Another was assembled in Rochester, N. Y., and completed and started on the road the day following. Both are the Class B truck designed for three-ton load, but with capacity for five tons. The assembling of these trucks, as well as the designing of them, sets a new record in American production, the first truck having come through two days ahead of the schedule set.

The two trucks that have been assembled have exceeded the expectations of not only General Chauncey B. Baker, of the Quartermaster Department, which has directed the work, but also of the two score of engineers and hundreds of draftsmen who worked on the design. Early tests of the engine showed 58 h. p. at 1,350 r.p.m., and the engine torque curve is better than anticipated. It is now assured that the United States heavy-duty war truck is one of the greatest engineering successes of the war, and that it is destined to revolutionize army truck work so far as operation and maintenance are concerned, and that the truck will play a large part in affecting truck design in commercial circles.

That the War Department, as well as the members of the Society of Automotive Engineers, who co-operated in the design work, is convinced that the truck is right, is shown by the fact that orders for 10,000 parts for the truck have already been placed, these orders including engines, axles and other parts.

Any apprehensions as to the truck being too heavy for its carrying capacity have been dissipated by the statement of weights given by those companies building the units entering into the first machines. The maker who assembled the first truck states that the total weight of the chassis without body is 6,500 lbs., which with a 1,600-lb. body will bring the total up to less than 10,000 lbs. The engine weighs 1,012 lbs. The rear axle weighs 1,592 lbs., with hubs and brake drums; the front axle, with hubs, 352 lbs.; the transmission, 233 lbs.; the clutch and case, 103 lbs.; the frame, without castings, 653 lbs.; the front springs, 148 lbs.; the rear springs, 544 lbs. With different makers these weights vary from 40 to 50 lbs. in such a case as the engine, and there are smaller variations with other parts. Without doubt, weights of these parts taken after they are well in production will show many cuts.

In summarizing the co-operative talent embodied in the

engine it might be said that the crankcase is Continental, the cylinders Waukesha, the oiling system a combination of Wisconsin and Buda, the pistons Hercules and the timing-gear system a combination of Buda, Wisconsin and Continental. The governor is a combination of Kelly-Springfield and Waukesha. The camshaft is a composite design. The engine has been designed with the thought of using the heavier fuels, the combustion chamber and other parts having been designed to meet these requirements.

What has been said of the engine can be said of the transmission, the axles and other parts. Three or four of the leading axle makers have worked together on the axle designs. So with the transmission.

So well have all the engineers co-operated that the schedule set for the completion of the different truck units, as well as of the completed truck, has been lived up to and generally improved upon. The first engines built in different factories were to have been delivered on September 30 and they were delivered on that date. The completed chassis was to have been ready October 10 and was ready on October 7.

### N. A. C. C. to Abolish Muffler Cutout

The National Automobile Chamber of Commerce, following a meeting of the directors held early in the month, announced that the members had voted unanimously to abolish muffler cutouts that can be operated from the driver's seat on the power vehicles they manufacture in the future.

In explanation of this action the announcement states that the cutout has become a nuisance inasmuch as it adds an unnecessary noise to American life, and as the machines have ample power for all purposes the small additional power gained by the cutout is of little consequence to the practical operation of the vehicles.

Many makers have for a long while ceased equipping their cars with muffler cutouts, a total of 110 makers having eliminated them for some time. The directors at their meeting adopted a resolution as follows:

"Members of the National Automobile Chamber of Commerce are opposed to the attachment of muffler cutouts to motor vehicles and do not fit them to the cars and trucks they manufacture, or will discontinue doing so on their product for 1918.

"The use of the cutout is unnecessary, annoying and dangerous to other users of the highways and objectionable to residents along them.

"The board of directors therefore recommends that all members of the National Automobile Chamber of Commerce refrain from attaching muffler cutouts to their cars for the season of 1918 and thereafter, and that no cars be sold by them after January 1, 1918, with cutouts attached, or that where cutouts are attached they be made inoperative from the driver's seat.

### To Discontinue Making Simplex Cars

The Wright-Martin Aircraft Corp., owner of the Simplex Automobile Co., New Brunswick, N. J., announces that the manufacture of Simplex cars will be discontinued for the duration of the war in order to devote the entire facilities of the factory to the production of Hispano-Suize motors, which are for airplane use.



## Forty-fifth Annual Convention of C. B. N. A.

The forty-fifth annual Carriage Builders' National Association convention was held at the Hotel LaSalle, Chicago, Ill., September 25, 26 and 27.

The first day's session, on Tuesday, was opened by President Theodore Luth, of Cincinnati, O., who introduced William R. Moss, of Chicago, who welcomed the members in a fitting address. He was followed by P. E. Ebrenz, a former president of the association, who responded to the address of welcome.

In his annual address President Luth made a plea for standardization of parts, and advocated co-operating with the railroads and government in the matter of transportation. He said:

"This is the forty-fifth annual convention of this association and we are the oldest body of business men associated in this country. This in itself is quite an honor. One thing that we have talked about at other conventions, but have paid very little attention to, is the matter of standardization. Our accessory people are getting busy helping win the war by making things for Uncle Sam, and necessarily they must confine themselves to such articles that we can all use.

"The day of individuality of the buggy builder must pass. We must get down to using standard material. I think, gentlemen, you want to consider that very seriously from now on. I know from our own experience, and from others, that there are numerous styles of axles, styles of springs, styles of bodies, styles of seats, styles of joints, and what-not all entirely unnecessary for the buggy today. You can almost all use the same material in your line and it will help considerably. The government says we should do our bit, and, as our worthy ex-president has said, our damndest; so let us try and do it by helping the accessory people to build for us material that we can all use and get promptly.

"That is another thing we must bear in mind—we want prompt deliveries. Prices are high today and we are all hesitating somewhat in loading up on high prices.

"Transportation is another subject I want to dwell upon for just a few minutes, and it is a very important question in our line of business. Shipments are very slow from all points, and we should all strive to load our cars to capacity—not ask for a 36 ft. car when we want a 40 ft. car—and by all means unload them promptly. Uncle Sam will be moving his troops to and forth and it will be absolutely necessary that we give the transportation problem all the consideration we can."

O. B. Bannister, in response to a call from President Luth, made a strong patriotic address.

The executive committee, in presenting its report, stated that the finances were in satisfactory condition. The report, in part, follows:

"Notwithstanding the withdrawal of a number of companies from the manufacture of vehicles, the attendance at this convention indicates increased interest in the work before them and in our association by those who are still engaged in this business.

"The president of our association has dwelt particularly

on the subject of standardization, and the committee recommends that the question receive careful consideration. In times such as we are passing through the committee feels that it is necessary and patriotic to subserve our individual ideas to one common purpose and limit our demand upon our sources of supply. With the increasing demand of the government for the material for the prosecution of the war, it will consequently be more difficult to obtain special supplies and the consequent damage to your business resulting from non-delivery.

"The statistical committee has, as usual, tabulated an exhaustive report upon the general volume of our business, and the committee is pleased to note that the vehicle business as a whole has shown little decline during the past two years. The indications are that it has reached

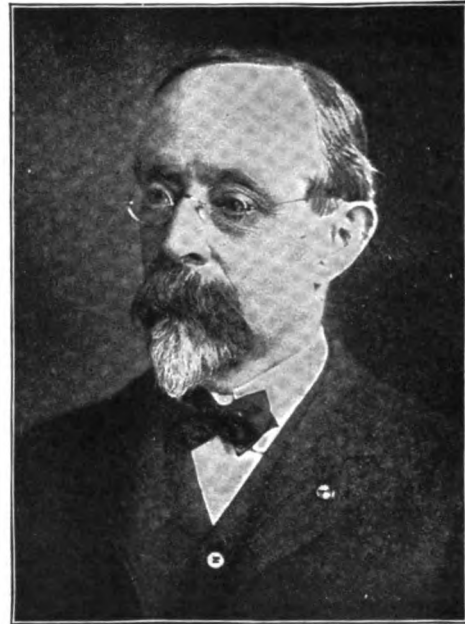

PRESIDENT THOMAS M. SECHLER

its lowest ebb and should show improvements. In this connection, the committee desires to extend its appreciation to those furnishing supplies who have continued their loyalty and support to the horse-drawn vehicle industry.

"The committee as in the past recommends the continuation of the building of good roads and that special provision be made to build the roads of sufficient width and character to properly accommodate the horse-drawn vehicle."

Homer McDaniel, Cleveland, O., addressed the members of the accessory trades. He said in part:

"I am glad to say that I have been attending these conventions for more years than I like to admit—probably thirty or more. The carriage industry has stood the strain of many changes and now it is one of the oldest business organizations in the country.

"The accessory trades; that is those who furnish you supplies, have remained in the industry, as I said a year ago, evidently with an idea of making money; otherwise

they would probably have quit. Few men remain in business strictly on a sentimental basis. One of the truest tests, it seems to me, of their fidelity to your organization is the fact that they furnish the means for your entertainment each year; and I cannot see, as I raise the money for this from year to year—or rather ask for it—any lack of interest; in fact, the money we will have for this year's entertainment came with the usual ease. True, a few men have gone entirely out of the supply business in your industry. I receive such letters, many of them with their regrets that they are obliged to discontinue coming to our conventions. For many years there will be orders sent you for materials for horse-drawn vehicles.

Henry S. Henschen, who replaced John J. Arnold as a speaker, and who is cashier of the State Bank of Chicago, selected as his topic, "How Banks Lend Their Money." He explained the rules that a banker followed in lending his money.

**Secretary-Treasurer's Report**

Secretary-Treasurer H. C. McLearn, Mount Vernon, N. Y., submitted his annual report from January 1, 1916, to January 15, 1917, as follows:

Cash in Bank January 1, 1916.....	\$1,114.23
Received from dues, exhibition dinner tickets and sundries .....	7,387.92
Associate Members Association.....	1,965.80
Special Freight Committee.....	575.00
Cincinnati Entertainment Committee.....	55.06
Hickory Products Association.....	50.00
	<hr/>
	\$11,148.01
Expenses during same period.....	8,595.02
Paid for the Associate Members' Association, Entertainment .....	1,408.60
Technical School—final payment.....	554.65
Cash in bank January 15, 1917.....	589.74
	<hr/>
	\$11,148.01

**New Members Elected**

The following were elected to active membership: Albert Armstrong, The A. Armstrong Co., Cincinnati; A. L. Black, A. Wrenn & Sons Co., Norfolk, Va.; N. J. Baxter, The Baxter Buggy Co., Hampton, Ga.; L. C. Fehring Carriage Co., Columbus, Ind.; Michael W. Hission, Union City Carriage Mfg. Co., Union City, Ind.; John B. Hower, The Akron-Selle Co., Akron, O.; R. J. Jones, The Henderson Buggy Mfg. Co., Henderson, N. C.; J. R. Knight, Knight Buggy Co., Franklin, Va.; J. A. Moores, Moores Buggy Co., Fayetteville, Tenn.; Thomas J. McNamara, Phoenix Buggy Co., Cincinnati; W. B. Pratt, Elkhart Carriage & Motor Co., Elkhart, Ind.; S. K. Rowland, Rowland Buggy Co., Sumter, S. C.; John H. Rowan, James C. Strong, Montgomery Ward & Co., Chicago Heights, Ill.; H. H. Wood, The Eureka Co., Rock Falls, Ill.; E. C. Witwer, The Studebaker Corp., South Bend, Ind.

New associate members are: W. J. R. Alexander, Wright Varnish Co., Cincinnati; J. L. Adams, Cambria Steel Co., Cincinnati; G. C. Foster, Evansville Carriage Woodstock Co., Evansville, Ind.; John W. Herron, Royer Wheel Co., Aurora, Ind.; J. F. Howerton, The Ohio Valley Tanning Co., Cincinnati; Richard Hirst, The Hirst-Rogers Co., Philadelphia; W. A. Jacob, Cincinnati Varnish Co., Cincinnati; Carl Kloos, The Enterprise Brass & Plating Co., Cincinnati; J. Lichtenaer, Standard Var-

nish Co., Cincinnati; S. W. Mitchell, The Mitchell Wheel Co., Miamisburg, O.; A. Nutter, Nutter Gearwood Co., Seymour, Ind.; W. O. Rutherford, The B. F. Goodrich Co., Akron, O.; C. J. Rennekamp, Auto Vehicle Parts Co., Cincinnati; F. H. Sawyer, The Goodyear Tire & Rubber Co., Akron, O.; L. C. Vaughan, James H. Rhodes & Co., Chicago; Roger Williams, Keystone Spring Works, Philadelphia.

At the last day's session the report of the freight and classification committee was read by Mr. Ebrenz, chairman E. M. Galbraith being unable to attend. The report indicated an active year just passed and urged the necessity of loading cars to their capacity, to unload promptly, and to assist in every way in moving the vast amount of products. E. G. Payton, of the Hercules Buggy Co., was given credit for most of the work of the committee and a vote of thanks was extended to him as well as to the committee for the excellent work performed.

**Report of Statistical Committee**

Requests were sent to 274 companies that were engaged in the manufacture of carriages in a wholesale way during the year 1914-15 and 1915-16. Responses were received from 145—25 of whom reported they had discontinued business since July 1, 1916—120 reporting a total product of 309,615 jobs.

There were 57 large manufacturers who did not respond. It is estimated that their total product was 42,673 jobs. It is considered a conservative estimate that there was at least 30,000 jobs produced by the smallest carriage and wagon manufacturers, not included in the above figures.

These estimates show a total product of new vehicles for the year 1916-17 of 382,288, as compared with 425,467 in 1915-16.

The Hickory Products Association sent their request to 50 wheel manufacturers, which represented the net number of manufacturers that reported their product in 1915-16. Of this 50, 39 reported the amount of their product—four reported that they had ceased the manufacture of wheels, and seven failed to report. Of the seven, none are large manufacturers, and four of the seven have unofficially been reported out of business. The number of sets reported is 59.5 per cent of the normal product of the factories reporting.

Following is the statement showing number of sets of wheels, number of shafts and poles, number of sets of axles, number of buggies, carriages, spring wagons (spring work) produced:

	Wheel Sets, Production, January to January	Poles and Shafts, Jobs, Production, August to August	Axles, Jobs, Production, September to September	Buggies, Carriages, Spring Wagons, Spring Work, Production, July to July
1905 .....	1,216,224	1,310,000	1,345,268	.....
1906 .....	1,292,874	1,540,000	1,463,331	.....
1907 .....	1,202,559	1,340,000	1,517,634	.....
1908 .....	812,501	1,040,000	1,946,493	.....
1909 .....	1,115,925	1,062,500	1,185,286	.....
1910 .....	1,201,105	1,325,000	1,349,782	.....
1911 .....	1,097,308	1,075,000	1,344,820	.....
1912 .....	963,305	1,025,000	1,141,484	.....
1913 .....	988,200	1,127,500	.....	.....
Jan., 1914, to July, 1914 .....	493,590	.....	.....	.....
July, 1913, to July, 1914 .....	.....	868,000	1,092,832	786,392
July, 1914, to July, 1915 .....	523,578	517,512	653,642	397,023
July, 1915, to July, 1916 .....	520,173	744,000	611,033	362,202
July, 1916, to July, 1917 .....	516,148	780,000	599,856	309,615

The following table will show the number reported by states, and the average percentage of normal product in each state, as compared with the years 1914-15 and 1915-16:

	Number of Jobs Reported, 1914-15.	Average Percentage of Normal Product.	Number of Jobs Reported, 1915-16.	Average Percentage of Normal Product.	Number of Jobs Reported, 1916-17.	Average Percentage of Normal Product.
Alabama	420	34	12	100		
Georgia	8,389	26	12,192	44	18,325	63
Illinois	65,654	55	41,272	53	36,443	41
Indiana	108,056	66	112,453	74	96,100	87
Iowa	11,047	60	5,194	32	4,431	36
Kentucky	22,857	63	34,356	78	40,907	94
Maryland	757	60	1,190	59	.....	.....
Massachusetts	260	28	344	33	94	60
Michigan	25,493	63	17,833	93	9,028	51
Minnesota	1,395	74	917	53	.....	.....
Missouri	45,650	56	47,486	62	30,332	67
New York	8,335	33	5,124	23	3,253	31
North Carolina	11,967	28	15,764	42	18,113	43
Ohio	55,832	59	47,513	60	37,143	61
Pennsylvania	16,228	58	7,575	36	3,950	33
South Carolina	1,770	20	2,636	35	623	33
Tennessee	2,056	82	.....	.....	.....	.....
Virginia	6,636	35	7,280	39	7,880	62
Wisconsin	4,641	73	3,103	50	2,981	41
	397,023		362,202		309,615	

The committee is informed by the Shaft and Pole Association that "according to our records, five-sixths of the 780,000 shafts and poles, jobs, reported, would be shafts, and one-sixth poles—which would indicate about 650,000 new vehicles or repaired vehicles, and 130,000 poles, which would be extra equipment." This assumes that all of the poles furnished were extra equipment—none of them being used for new work without shafts.

O. B. BANNISTER,  
Chairman.

George E. Frazer, of Chicago, formerly professor of political economics of the Illinois University, but now head of the firm of George E. Frazer & Co., certified accountants of Chicago, addressed the convention on "Operating Use of Cost Records." He was followed by John J. Arnold, vice-president of the First National Bank of Chicago, in an address on the new position of the United States in world politics.

**New Officers**

Following are the officers elected for the ensuing year:  
 President—Thos. M. Sechler, Moline, Ill.  
 Secretary and Treasurer—Henry C. McLearn, Mt. Vernon, N. Y.  
 Vice-president of states represented—A. H. Ahlbrand, Seymour, Ind.; B. M. Blount, Atlanta, Ga.; F. A. Ames, Owensboro, Ky.; J. D. Craft, Evansville, Ind.; A. M. Parry, Indianapolis, Ind.; Jas. B. Kaler, Columbia City, Ind.; H. A. Crawford, Kalamazoo, Mich.; Glen Perrine, Cincinnati, O.; H. A. White, High Point, N. C.; Thos. B. Tyson, Carthage, N. C.; J. R. Knight, Franklin, Va.; John Gummer, Elkhart, Ind.; Jas. H. Birch, Jr., Burlington, N. J.; M. W. Quinlan, Brookline, Mass.; John J. Delker, Henderson, Ky.; J. A. Moores, Fayetteville, Tenn.; Geo. E. Seidel, Richmond, Ind.

Executive Committee—W. H. Roninger, St. Louis, Mo.; Theo. Luth, Cincinnati; Frank H. Delker, Henderson, Ky.; E. J. Schlamp, Henderson, Ky.; W. E. Maxwell, Indianapolis; J. H. Poste, Columbus, O.; W. G. Norman, Griffin, Ga.; A. C. Hill, South Bend, Ind.

O. B. Bannister was selected by the Accessory Association as its representative, to serve two years on the executive committee.

The selection of the city for holding the forty-sixth convention was left to the executive committee. There was a strong sentiment in favor of Atlantic City, but the action taken will probably result in Cincinnati being chosen.

**Resolutions**

The following resolutions were adopted:

No. 1—"That all war buying should be assembled under the control of one board or executive department, and that this war supply board or department should be given full power to procure war supplies to the best advantage to the government as to price, quality and delivery and in a way to maintain essential industrial life without disturbing social and economic conditions; including the power to fix prices not only to the government but to the public on essential products and to distribute output in a manner to promote the national defense and the maintenance of our industrial structure, and that Congress be hereby requested to pass such statute as may be necessary to give the President of the United States all power necessary to concentrate in this manner the resources and the industrial energy of our country toward winning the war."

No. 2—"That we urge all industries not already organized to become so at the earliest possible moment; and that all such industrial organizations should appoint a war service committee independent of any governmental committee, such committee to be made up of representative men in the industry whether or not they be members of such organization; and that in all matters pertaining to any given industry the government should deal with the committee wherever possible, leaving to it where practicable the proper distribution of all orders for material."

No. 3—Recommending to Congress "That the [war tax] bill or law be so amended as to cause the total tax, when above a certain amount, to be payable in four quarterly installments."

Following is the record of deaths of members reported during the past year. Resolutions of sympathy were extended to the relatives:

- George Kellner, 86, Paris, France; one of the largest manufacturers in that country; died December 12, 1916.
- George H. Babcock, 64, Watertown, N. Y.; president of the C. B. N. A. in 1898; died December 12, 1916.
- James F. Taylor, 66, Cincinnati, O.; died June 19, 1916.
- J. F. Dugan, Chicago; died June 30, 1916.
- A. P. Cleaveland, 76, Detroit; died February 28, 1917.
- W. B. Conklin, 58, New York; died January 4, 1917.
- Frederick B. Hawley, 78, Bridgeport, Conn.; died March 4, 1917.

After passing resolutions of thanks to the officers of the association, the various committees responsible for the entertainment, the Hotel LaSalle for courtesies extended, the press, and the exhibitors, the convention adjourned.

**Annual Banquet**

The annual banquet of the Carriage Builders' National Association was held in the Louis XV. dining room at the Hotel LaSalle on Thursday evening, September 27. Theodore Luth was toastmaster. Capt. R. Hugh Knyvett, of the 15th Australian Infantry, during the course of the dinner addressed the audience on the subject "With the Australians in Gallipoli, Egypt and France." His descriptions of the battles in Europe had his hearers wrought up to highest pitch. He was vociferously applauded throughout. John D. Shoop, superintendent of the public schools of Chicago, spoke on "Business and Education."

A message was read from J. D. Dort, an ex-president of the association and now in the automobile business. "All hail to the old guard," it read, "who gather together each year to keep alive the friendship and close business relationship of many years' standing."

Following the banquet dancing was indulged in.

## Annual Meeting of C. H. A. T.

The twenty-seventh annual meeting of the Carriage, Harness and Accessory Traveling Salesmen's Association was held at Hotel LaSalle, Chicago, Monday evening, September 24. President Niehaus called the meeting to order and the following officers were elected for the ensuing year:

President—J. Frank Hutcheson, editor of the Spokesman, Cincinnati, O.

Vice-president—W. C. Martin, Elgin, Ill.

Secretary-Treasurer—E. G. Schick, Cincinnati, C.

Board of Directors—Grant Wright, chairman, Philadelphia, Pa.; E. A. McGrew, New York City; F. D. Reed, Boston, Mass.; P. D. Randall, Springfield, Mass.; G. W.



J. FRANK HUTCHESON,  
President

E. G. SCHICK,  
Secretary-Treasurer

Huston, Cincinnati, O.; G. A. Tanner, New York City; H. C. Jay, Cincinnati, O.; H. S. Cox, Detroit, Mich.; W. R. Scott, Detroit, Mich.; J. A. Niehaus, Cincinnati, O.; J. L. Nelson, Brooklyn, N. Y.

President Theodore Luth, of the Carriage Builders' National Association, was elected honorary member.

The annual dinner was held at Hotel LaSalle, Tuesday evening, over 200 members and guests being present. President J. A. Niehaus presided with quiet dignity and made an inspiring address. The principal speaker of the occasion was Grant Wright, of Philadelphia, who made one of his characteristic talks, full of stories and anecdotes that put everybody in good humor. President-elect J. Frank Hutcheson made a stirring patriotic address in which he flayed Senator La Follette and Mayor Thompson.

Theodore Luth, of Cincinnati, retiring C. B. N. A. president, made an address, as did also T. M. Sechler, the president-elect of the C. B. N. A. The speakers all paid tribute to Jesse L. Nelson, the retiring secretary-treasurer.

## Meeting of Carriage Builders

The carriage builders attending the C. B. N. A. convention held a special meeting Thursday, September 27, during which matters of vital importance were discussed.

The following gentlemen were present: S. H. Barrett, Post Bros. Co.; E. A. Johnson, Eckhart Carriage Co.; Louis Burg, Burg Carriage Co.; E. J. Schlamp, Geo. Delker Co.; Mr. Wittmer, Studebaker Carriage & Wagon Co.; John Gummers, Noyes Carriage Co.; A. H. Ahlbrand, Ahlbrand Carriage Co.; Theo. Luth, Luth Carriage Co.; F. A. Delker, Delker Bros. Co.; W. H. McCurdy, Hercules Buggy Co.; C. A. Crawford, Moon Bros. Carriage

Co.; A. C. Hill, The Studebaker Corp.; J. A. Moores, Moores Buggy Co.; E. A. Kirk, F. A. Ames Co.; E. E. Hughes, Hughes Buggy Co.; T. N. Robinson, Robertson & McGill Buggy Co.; T. M. Sechler, D. M. Sechler Carriage Co.; Wm. Knapp, Hickory Carriage Co.; P. P. Hunter, American Carriage Co.; Chas. Lancaster, Colfax Mfg. Co.; W. H. Roninger, Banner Buggy Co.; F. A. Baker, Emerson & Brantingham; E. J. Bard, Kratzer Buggy Co.; Clen Perrine, Brown Carriage Co.

## New Overland Model Will Sell Under \$500

The first real rival of the Ford car is indicated in the announcement of the Willys-Overland Co., Toledo, O., that it will manufacture a new model that will sell under \$500 and will carry a complete equipment, including electric starting and lighting and combined-dimmer control. An extra tire, and will weigh around 1,500 pounds.

The body is somewhat different from other Overland types, due largely to a unique system of springs, which give a distinctive appearance to the front and rear. The wheelbase is 100 in., but it is claimed that this spring suspension system gives the effect of a car having a wheelbase of much greater length.

The new machine possesses a four-cylinder engine, a two-speed sliding gear transmission, as against the planetary gearing of the Ford; a unique spring suspension which precludes the necessity of shock absorbers; electric lighting and starting that is really designed for the car and sold with it, instead of being tacked on afterward at additional expense. New records are expected to be made in gasoline consumption and tire life when the cars get into the hands of owners. Plans are being made for enormous production for next season.

## Guaranteed Truck Wheels

The wheel maker of this country has always excelled, therefore it not only is difficult, but it is an achievement to do something in this line that is outstandingly good.

The Wayne Wheel Co., at Newark, N. Y., has been in the business a long time and has followed the evolution of the commercial wheel, always making the kind the times demanded, but always also making it a very good kind. This means very skillful handling of stock that has been selected with the good judgment of long experience.

All the vehicle wheelmakers we have ever known who had earned big trade reputations started from the foundation of perfect stock and were mighty careful to keep the standard AA1. No good wheel can be made otherwise and it is a pity more auto truck makers do not sense this point.

This concern has all the mechanical appliances to handle the stock, has the right stock, so must naturally have a wheel that isn't ashamed of itself under any test.

## Death of George W. Houk

George W. Houk, vice-president of the Wire Wheel Corp. of America, and well known in the automobile industry as the promotor of the wire wheel, died at his daughter's home in Hollywood, Cal., on Saturday, October 6, following a second attack of the paralysis with which he was stricken less than a month before. He was 52 years old. He leaves a daughter, Mrs. Margaret Houk Moody. Her husband is manager of the Houk business in California.

## Paint and Varnish

### Preparing the Car for Painting

That it is not all painting to paint, the practical man will freely tell you; he will even tell you that the greater part of his work has to do with cleaning and smoothing and leveling the surface—in other words, getting a surface. In the cleaning and preparing the surface for painting the first step, and in a way the most important step, is to get the car, from wheelbase to top, clean as a hound's tooth. Perhaps the car that has been liberally dosed with polishing material offers the hardest problem from the cleaner's standpoint. Also the car that becomes through a long period of neglect coated under a smear of grease and road accumulations is one that must necessarily require some special attention.

In the first place the grease spots have to be dissolved; for this purpose raw linseed oil is a very effective and economical medium. Apply the oil freely to the smears and allow several hours for the dissolving process, after which wipe with strips of burlap for the first wiping; then follow with clean waste, either colored or white, the latter being the best. The next process consists of knocking down the nibs and roughage, if any, of the surface, and this may be done by rubbing with water and pumice stone flour, using a fine grade of the latter. If the surface is one over which polish has been used freely it will be found necessary to substitute for the water a pure grade of turpentine. Use this medium freely as a dipper for the rubbing pad, which for this work had best be a ½ in. perforated felt block. Some well-applied "elbow grease" will be needed to start the old film of polish. There are, of course, numerous formulas for the removal of the polish, but many of these are of such strength and dissolving properties as to be entirely unsafe in the hands of any one unacquainted with them. The turpentine and pulverized pumice stone will get the scum off when applied vigorously; then give the customary water and pumice stone flour rub, wash up clean and proceed with the painting operations.

A careful inspection of every car taken in should be made in order to discover the presence of the polish. The removal of this from the surface preparatory to painting should be classed as an extra process and either charged as a direct operation or an overhead expense. It certainly must be paid for by the car owner, otherwise the painter must perform a very difficult job of work gratis. Many of these surfaces after being purged of a mass of refuse disclose a condition which must be taken care of by means of some primary processes before the regular work of painting may be taken along. This, perhaps, will take a coat of lead and oxide paint, or an oxide paint and lampblack, carrying sufficient raw linseed oil to fasten the pigment securely to the surface. Apply this carefully, treating it until the material lays smooth and clean and well brushed out. When dry this coat may very well be used as the base to putty upon. The surface in due time will need a thorough looking over for any inequalities, and any of these should be puttied with a

hard drying carriage putty. All rough spaces, depressions, etc., will need facing up with the putty let down somewhat with turpentine, so that it will work nicely from the point of a broad half-elastic putty knife, or scraping knife.

The Russian carriage and car painter uses much of this material to get his surface with. In that country the putty is applied with a broad scraping knife until the necessary depth of pigment is secured, after which when dry it is rubbed down with blocks of rubbing brick, quite as we would rub roughstuff. In the newest of republics very durable and fine carriage and car painting is done, and if it is found available there, then we can see no reason why the American automobile painter may not use the facing putty to a far greater extent in the fetching up of an old surface for the color and varnish coats than he has hitherto apparently been willing to.

Dents in the metal panels and various defects of the surface may be brought out full and flush with the surface as a whole, with the putty dough. The main thing in applying this facing material is to get it on without any sharp, rough edges. These, when dry, are very hard to work down smooth and even, and require an extra amount of surfacing work. Our plan is to get this pigment onto the surface so smoothly as to make it possible to sand-paper it quite good enough for much of the repainting work that comes along. But for strictly first class work it should be rubbed with water and artificial pumice stone or rubbing bricks. It is a good plan to turn this facing with putty work over to some one employe who shows a natural aptitude for it; the workman then soon becomes a specialist and will shortly be able to turn out work that one may marvel at. The main thing in repainting is to get the surface in proper trim through the processes outlined above; the painting may then be carried along at the minimum amount of labor and material without menacing the appearance or the durability of the finish secured.

### Roughstuff and Its Uses

Perhaps the time may come when this material can be dispensed with altogether, but its end is not yet. Today, as through all the years that are past, it is the one superior material for making the surface par excellence over which to apply the matchless finish. To secure the most desirable results with roughstuff it is first necessary to treat it as becomes its nature and office. The detail work leading up to the use of the 'stuff must consist of some very thorough processes. There must be the required priming and preparation coat, and over these must be placed a good share of the putty that is to be used. Important, too, it is that these operations are performed with an eye single to getting from the very start a smooth and level foundation. That makes it so much easier for the 'stuff; it also is the means of saving a material which during these days of war comes high like everything else.

There is a question which is the more economical—the shop mixed or the material purchased ready for use. It finally, in most cases, resolves itself into one of individual

preference. Personally, after many years of employing the bought-ready-to-use 'stuff, we prefer the latter; it is always in form, with but a little mixing and stirring, for application; and if purchased of reliable firms its quality is as a rule prime and dependable. However, circumstances, location and conditions are often such that it is prudence to get the raw material and shop prepare the 'stuff supply. In these cases it is always economy to use an Al material out of which to make the roughstuff. While its name implies a rough material the ingredients should be fine and excellent in quality, and they need to be prepared with skill and due attention to details. Equal parts of keg white lead, ground in oil, and any good filler, by weight, beaten to a stiff mass in equal parts of rubbing varnish and japan—pale drying or coach—and then thinned to a working consistency in turpentine is the process of mixing.

The essential thing, as already stated, is to use good materials. Slush turpentine and varnish odds and ends do not belong in the makeup of a batch of 'stuff. More refinement of the material is needed than such material affords, hence nothing but the best should find its way into the container holding the 'stuff. In application it needs to go the surface a little heavier in body than ordinary paint and yet be sufficiently thin and supple in form to flat down smooth and entirely free from brush marks. Brush marks are difficult to erase. The cure is prevention. The smoother the 'stuff is laid the cheaper it may be surfaced.

### Cleaning For and Applying the Finishing Coat

The cleaning of the surface preparatory to applying the finishing varnish is one of the highly skilled jobs connected with the painting and finishing of vehicles. It is a class of work that to the layman looks easy, but it is all in the know how—in the appreciation of a number of important details and the skill to carry them out. It is necessary to begin with, to have the surface conditions very nearly perfect; to have the rubbing varnish coats laid with every attention to the refinement of the job; to have them flowed on faultlessly, and rubbed with all the little niceties given due attention. Then in preparation for the finishing varnish the washing belongs to an art.

One of the great finishers when carriages were in fashion and Cortland flashed on the map as a famous vehicle center, told the writer that a great many men were capable of applying the varnish, but very few were a success in making the surface clean and ready for the varnish. In fact, it was the opinion of this widely known finisher that it was a more difficult work to wash and clean the surface than to varnish it afterward. Plenty of soft, clean water is needed; two sets of sponges, chamois skins, wash tools, pails, etc., are required—one for the first washing, another for the second.

In the work of washing use plenty of water; with the wash brush tool out all the places likely to retain dirt atoms and foreign substances generally. Be particular about the under edge of the body surface. Around ornaments, moldings, etc., flood the water on freely and then tool out carefully. Then come to the final washing; be quite as thorough with this as with the first. Use a wash leather entirely free from lint; rub the surface just firm enough with the leather to catch away the water in bulk. The clinging vapor will evaporate and leave the surface

in better shape than the rubbing necessary to take up all the moisture.

In the application of the varnish, after the final dusting with the bristles flicked with a spray of finishing varnish, go at the work with confidence. Apply the varnish with horizontal brush strokes, flowing the varnish on in a volume measured fully up to all that the surface will take care of. Cross brush it well; then for the second time brush it out with the horizontal stroke. Then lick up the edges with a bear's hair  $\frac{3}{4}$  in. brush, and behold! the finishing coat is in place, and, let us hope it may stay there and round out and shine on for a period that will make all parties concerned completely satisfied.

### Getting Business

It is sometimes surprising to note the business secured from a little extra effort in canvassing. The average car owner is susceptible to argument, and especially to one which promises to save his car equipment from reaching a state of ugly looks. The right word at the right time will often be the means of picking up a considerable item of business, and these added items, picked from here and there, serve to keep the painting business from going into a condition of general decline.

The early winter months may be turned into a season of busy days for the painter if business is solicited in the proper way and in the right spirit. The car should as a matter of protection be given at least two coats of varnish annually—spring and autumn—and if the owner can be made to see the economy of the investment he is rarely inclined to defer making it. It would have been better perhaps to have had this work done a little earlier in the season, but these late pick-ups help to keep the force employed and in addition will aid in clearing the decks for action the coming spring when the shop will be crowded with a great volume of work. Then, too, it may be shown the car owner that it is to his advantage to have the work performed now, since business is going easy and there is no excuse for crowding the processes or rushing the work. The late run of work is well worth going after; and now is the accepted time to get it. If not, why not?

### Primary Processes for the Steel Surface

The steel surface demands a different treatment for the primary processes than is given wood. For one thing, the steel surface is not capable of taking up and absorbing the same quantity of oil or other priming material that the wood surface does.

After the metal has been cleaned thoroughly it should be primed with a mixture carrying a reduced quantity of oil and an increased volume of turpentine. One part oil and three parts turpentine will serve as the thinning mediums for the metal primer. The coat following the primer should also be mixed to carry a diminished measure of oil as compared to the turpentine.

The steel surface as it is brought along to the roughstuff stage should also be studied with reference to its levelness—to its hills and hollows. These, if any, will need to be taken care of in a manner to insure at the point of the color, a surface absolutely level. This will necessitate draw puttying the uneven surface with hard putty let down to a glazing condition with turpentine, this in due time to be rubbed down perfectly.



### W. P. Wood, Pittsfield Coil Treasurer, Dead

W. P. Wood, treasurer and organizer of the Pittsfield Spark Coil Co. in 1904, died September 29 after four weeks' illness from a complication of diseases which in reality was a recurrence of a severe illness of a year ago. Mr. Wood was born in Gloucetsershire, England, June 9, 1853, and came to this country at the age of eight, locating in Pittsfield. Mr. Wood was a political leader and ranked



very high in Masonry. Besides being president and general manager of the Pittsfield Spark Coil Co. he was a director of the Pittsfield National Bank, and was formerly a director of the Wilcox & White Co., of Meriden, Conn., and of the Boston Mutual Life Insurance Co. He is survived by his widow, two daughters, two sons, and seven grandchildren.

### An Argument for Price Fixing

Some consumers of steel have been complaining in the past fortnight that they cannot buy steel at the prices fixed, in a tone suggesting an idea that therefore the price fixing is more or less of a failure. Such buyers should reflect that the refusal of mills to sell is proof that if there were an open market buyers would run up the price until through competitive bidding sales would occur. That obviously would not be to the advantage of buyers as a class. It certainly would not help win the war for the decision whether steel is needed for war to be allowed to depend upon the price a buyer is willing to pay.

The distribution of the steel will be regulated by the Priority Board, price not entering into the question. The buyers are protected as to price and all should be well satisfied. The great majority are well satisfied.—American Metal Market and Daily Iron and Steel Report, October 5, 1917.

### Racine Auto Tire Buys Wagon Plant

The Racine Auto Tire Co., Racine, Wis., has purchased the group of factory buildings at State and Marquette streets, formerly occupied by the Fish Bros. Wagon Co., and is remodeling the plant into a tire and rubber goods factory, which will employ between 500 and 600 operatives and afford an area of 250,000 sq. ft. The company last

fall purchased about 14 acres, and had completed plans for the erection of a new plant costing \$150,000 or more, when it was enabled to purchase the Fish wagon works from the present owner at a price said to be \$200,000. So far as can be learned the new construction scheme will now be postponed indefinitely. L. J. Elliott is president and general manager.

### Pneumatic Tires Advantageous for Trucks

Truck manufacturers and users generally advocate the use of solid tires, but evidence shows that the pneumatic tire, properly proportioned to the load, is as advantageous for trucks as for pleasure vehicles. The test on a Packard 1½ ton army transport truck was recently made over a distance of 4,288 miles from Detroit, Mich., to the Mexican border and back. The truck was fitted with 36 x 7 in. "Nobby" tread U. S. pneumatic tires. The conclusions drawn from the trip are that an average of 40 per cent more mileage per gallon of gasoline can be obtained from trucks equipped with pneumatic tires than from those equipped with solid tires, and that oil consumption is reduced from 25 to 30 per cent. The pneumatic tires greatly reduce road shock and lower truck depreciation fully 50 per cent. The average mileage per gallon of gasoline was seven, and the lubricating oil consumption of the trip was one quart of oil per 33.42 miles.

### Big Army Order for Wagons

A contract for the construction of 400 army escort wagons, to be used by the United States military forces, has been awarded the Springfield (Mo.) Wagon Co. The order is equivalent to a contract for 1,200 farm wagons. The army wagons will weigh 2,100 or 2,200 pounds, whereas the regular farm wagon weighs between 1,200 and 1,300 pounds. The order calls for the delivery of wagons to begin on January 1 and to be completed by June 30. A large number of additional men will be employed.

### Brewer-Titchener Will Control Five Plants

Crandal-Stone & Co., Binghamton, N. Y., has been merged with the Cortland Carriage Goods Co. and the Cortland Forging Co., both of Cortland, into a new corporation under the style Brewer-Titchener Corp. The company will control five plants, making drop forgings, metal stampings, bow sockets, step hangers, etc. Directors for the first year will be C. E. Titchener, B. M. Stannard, E. H. Brewer, E. A. Brewer, R. L. Brewer, F. L. Titchener, C. M. Devaney, M. C. Wood and R. P. Higgins.

### Moon Takes Over Buggy Plant

The Moon Motor Car Co., St. Louis, Mo., has taken over as a part of its plant the works of the Joseph W. Moon Buggy Co., which makes the motor plant cover the entire block, including factory buildings recently acquired. Additional machinery is being installed to insure the completion of 20,000 of the new "Thousand Dollar Six" model.

**Defiance (O.) Machine Works** is expanding to twice its present size and is advertising for 200 to 300 skilled mechanics. In addition to being rushed with orders for their regular line of tools the company has been awarded a large government contract which necessitates the erection of additional buildings. It has purchased two adjoining blocks of land and construction work is under way.

## The Victor Pump

Nothing is better than a good tire pump, nothing in the tool box causes more annoyance than the other kind. A dealer or manufacturer who overlooks such obvious facts for the sake of a little financial edge is not a thinker. The details are what please or annoy a car owner the most.

This is introductory to the mention of a really fine tire pump—The Victor—made at Clifton Springs, N. Y., by the Judd & Leland Mfg. Co.

In the first place it is a workmanlike apparatus, built

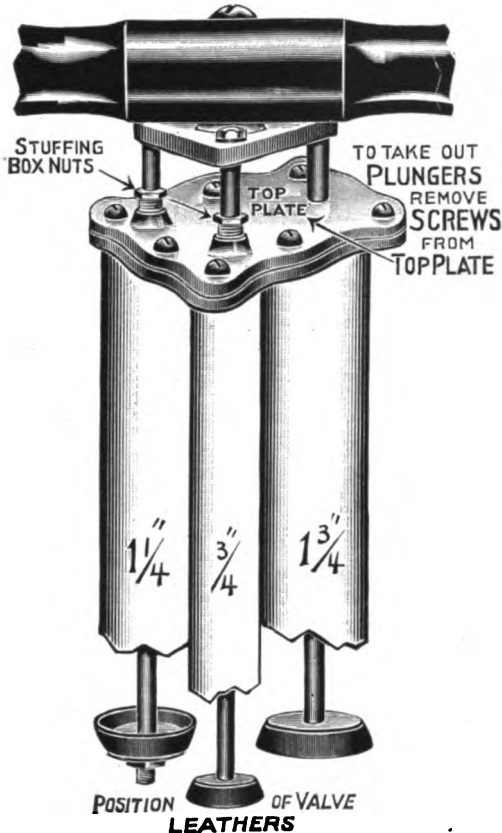

to serve as much as to sell. The real working end, the plunger and valves, is here illustrated. It is triple compression, made on well thought out mechanical lines. If you are wise to the "innards" of air pumps you will seize the point quickly.

Now, as to the making. Naturally, if you are making something theoretically good, you are a fool if you do not make all the materials that go into the apparatus such that they will establish the theory in practice.. That is an outstanding feature of the Victor. Tubes of seamless brass, the leather caps of best leather, the workmanship

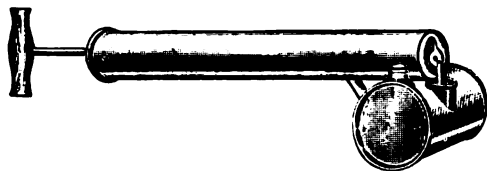

the crown of the job. What more need be said save to do the ante buying investigating for yourself. We are leading you to a good article.

In this connection, however, we ought to add that there is a line of sprayers made that are just as satisfactory in their way as the pump is in its. They will use disinfect-

tants (good about the trimmings), insecticide, and even polish of a liquid nature may be applied. They are a very practical, sturdy implement that can be used to advantage in the garage. We show an illustration.

## Standard Parts Extensions

The Standard Parts Co., Cleveland, O., will enlarge its Cleveland axle plant in Canton, O., and has purchased two 7,000 lb., two 5,000 lb. and two 3,000 lb. hammers, six trimming presses, lathes, milling machines and other machine tool equipment, and will rebuild the plant boiler house and install new boilers. The company will also make extensions to its Hess-Pontiac spring and axle plant, Pontiac, Mich., expending about \$45,000 for building extensions and \$10,000 for equipment. In Toledo it is enlarging its Bock-Bearing plant with an addition of 100 x 225 ft., at an expense of \$175,000, and will add about \$50,000 in equipment, including special machinery and boiler plant equipment. Its American ball bearing plant in Cleveland will be enlarged by the addition of about \$50,000 in equipment which will, for the most part, be special machinery.

## Bonus for Mitchell Wagon Co. Employees

The Mitchell Wagon Co., of Racine, Wis., which went into liquidation on August 1 of the current year, voted bonuses to 75 of the employees in the office, sales organization and factory for faithful service rendered the company during its existence. The total amount so distributed was \$40,000 and the checks ranged from \$100 to \$5,000 each, according to the period of service and annual compensation. The company has established offices in the Badger Building at Racine, where the affairs of the company will be handled until every department of the business can be closed up. The principal work will be making collections and looking after the settlement of accounts.

## STATEMENT OF THE OWNERSHIP, MANAGEMENT, ETC., REQUIRED BY THE ACT OF CONGRESS OF AUGUST 24, 1912, OF THE HUB, published monthly at New York, N. Y., for October 1, 1917.

State of New York,  
County of New York, ss.

Before me, a Notary Public in and for the state and county aforesaid, personally appeared G. A. Tanner, who, having been duly sworn according to law, deposes and says that he is the Business Manager of The Hub, and that the following is, to the best of his knowledge and belief, a true statement of the ownership, management, etc., of the aforesaid publication for the date shown in the above caption, required by the Act of August 24, 1912, embodied in section 443, Postal Laws and Regulations, to wit: Publisher, Trade News Publishing Co., 25 Elm St., New York, N. Y. Editor, G. A. Tanner, 25 Elm St., New York, N. Y. Managing Editor, none.

Business Manager, G. A. Tanner, 25 Elm St., New York, N. Y.  
2. That the owners are: (Give names and addresses of individual owners, or, if a corporation, give its name and the names and addresses of stockholders owning or holding 1 per cent or more of the total amount of stock.)  
Trade News Publishing Co., 25 Elm St., New York City,  
Paul Morse Richards, 25 Elm St., New York City.  
G. A. Tanner, 25 Elm St., New York, N. Y.

3. That the known bondholders, mortgagees, and other security holders owning or holding 1 per cent or more of total amount of bonds, mortgages, or other securities are: None.

4. That the two paragraphs next above, giving the names of the owners, stockholders, and security holders, if any, contain not only the list of stockholders and security holders as they appear upon the books of the company but also, in cases where the stockholder or security holder appears upon the books of the company as trustee or in any other fiduciary relation, the name of the person or corporation for whom such trustee is acting, is given; also that the said two paragraphs contain statements embracing affiant's full knowledge and belief as to the circumstances and conditions under which stockholders and security holders who do not appear upon the books of the company as trustees, hold stock and securities in a capacity other than that of a bona fide owner; and this affiant has no reason to believe that any other person, association, or corporation has any interest direct or indirect in the said stock, bonds, or other securities than as so stated by him.

G. A. TANNER, Business Manager.

Sworn to and subscribed before me this 4th day of October, 1917.  
(SEAL)

JOSEPH R. FRITH,  
Notary Public, New York County.  
(My commission expires March 30, 1918.)

# Vehicle Industry News in Brief

## Truck Builders

**Armstrong-Whetstone Co.**, Lapeer, Mich., is now turning out an automobile trailer.

**Line Drive Truck & Tractor Corp.** of Portland, Me., has been incorporated with a capital of \$4,000,000.

**Fulton Motor Truck Co.**, Farmingdale, L. I., output is to be increased to 2,500, compared with 1,000 during the past 12 months.

**Buffalo (N. Y.) Truck & Tractor Co.**, has been incorporated by G. B. Burd, E. H. Oversmith, and S. B. Simpkins, capital \$150,000.

**Jordan Motor Car Co.**, Cleveland, will assemble motor trucks from units of good quality, in addition to its passenger car output.

**Amston Motor Car Corp.**, capital \$3,000,000, has purchased the principal assets of the Sterling Automobile Mfg. Co., Inc. of New York.

**Transcontinental Motor Truck Corp.**, Buffalo, has been incorporated, capital \$1,250,000 by E. S. Stengel, R. A. Schmidt and P. J. Bloxham.

**Grant Motor Car Corp.** has acquired the plant and business of Denneen Motor Co., Cleveland and will continue the manufacture of Denmo trucks.

**Conestoga Motor Truck Co.**, Woolworth Building, Lancaster, Pa., is having plans prepared for the construction of a one-story brick and concrete building about 60 x 200 ft.

**Rice-Macrae Motor Truck Co.**, Newark, N. J., has been incorporated with a capital of \$10,000 to manufacture motor trucks. Frederick T. Macrae, 228 Halsey street, and A. L. Rice are the incorporators.

**Master Trucks, Inc.**, Chicago, maker of the Master 2-ton truck, has sold \$890,000 worth of trucks to the M. C. W. Motor Sales Corp., New York. The company has been turning out trucks for four months.

**International Motor Car Co.**, Allentown, Pa., has received a government order for 1,000 motor trucks, each of 8 tons capacity, which, it is said, totals \$4,500,000. The work will be handled at the local plant.

**Duplex Truck Co's.** plant at Grand Rapids, Mich., will be completed by Nov. 1. It is 72 x 402 ft., with a wing 72 x 306 ft., two stories, and will have a capacity of 75 trucks per month. H. M. Lee is general manager.

**Grand Rapids (Mich.) School Equipment Co.** is assembling material for an order of 6400 motor truck bodies for the Government. The first delivery will be in December and it is expected the production will be at the rate of 1000 a month.

**George L. Carroll Co.**, Philadelphia, has been incorporated in Delaware with capital of \$25,000 to manufacture automobiles and motor trucks. George L. Carroll, Alfred F. Brachm, and Harry E. Prutzman, Philadelphia, are the incorporators.

**Smith Motor Truck Corp.**, organized under the laws of the state of Virginia, with a capital stock of \$40,000, has been granted permission to manufacture motor trucks, automobiles, vehicles, etc., in Ontario. M. A. Stratton, Toronto, Ont., is the attorney.

**Muskegon (Mich.) Engine Co.** has let the contract for a factory 75 x 160 ft., to cost \$25,000, for the manufacture of a 2-ton commercial truck, and by Oct. 1 it expects to be producing at the rate of 25 trucks a month. The company has a capital stock of \$150,000.

**Burlington (Wis.) Motor Truck Co.**, organized recently with a capital stock of \$50,000, has leased manufacturing quarters and will build 600 commercial car units for attachment to Ford chassis by Jan. 1, 1918. The design employs the Torbenson internal gear drive rear axle. A Chicago office has been opened at 160 West Jackson Boulevard.

**United States Motor Truck Co.**, Cincinnati, during the past year increased production and sales 1000 per cent. Output for the coming year will be doubled. A building two stories high, 490 x 90 ft., will be used for the progressive assembly system which will replace the present method of group assembly. At the present time the plant covers 353,000 sq. ft. of space.

**Lakewood Engineering Co.**, Cleveland, has purchased the plant of the Galion Dynamic Motor Truck Co., Galion, Ohio, which it will use for the manufacture of storage battery trucks and trailers, with a four wheel steer and four wheel drive. An extension will be built as soon as plans can be prepared. In addition to this and its Cleveland plant the company now owns and operates works in Elyria, O., and Milwaukee.

## Body Builders

**Universal Truck Body Co.**, Jonesville, Mich., is erecting a new factory and enlarging its force.

**Lang Body Co.**, Cleveland, O., will erect a new building for manufacturing purposes at a cost of \$75,000.

**Fisher Body Corp.**, Detroit, has let a contract for a one-story steel factory, 190 x 560 x 23 ft., for its aeroplane division, to cost \$200,000.

**Wangler Co.**, Pittsburgh, Pa., makers of tops, seat covers and sheet metal products, has engaged in commercial vehicle body manufacturing.

**Bay City (Mich.) Auto Body Co.** has received an order for 25 truck bodies per month from a Detroit company manufacturing trucks for the government.

**Wangler Co.**, Pittsburgh, Pa., has entered the commercial body manufacturing field, after having engaged in the manufacture of tops, seat covers and sheet metal work for several years.

**Russell Carriage Co.**, Kansas City, Mo., has purchased a site for the erection of a plant to cost \$30,000 to manufacture bodies for passenger automobiles. Frank T. Russell is head of the company.

**Olympian Motor Co.**, Pontiac, Mich., has bought out the Meridian Mfg. Co., Indianapolis, Ind., which makes bodies and will move everything to Pontiac and manufacture its own bodies at output of 20 per day.

**Acme Convertible Body Co.**, Indianapolis, Ind., has been incorporated to manufacture convertible automobile bodies, capital \$10,000, by Joseph Butterworth, Edward Marosky, Henry Marosky, Richard A. Gahr.

**Auto Body Co.**, Lansing, Mich., has orders on its books totaling \$1,750,000. The company's business has doubled in the past year and the increased business will be financed by the sale of \$250,000 unissued treasury stock.

**American Auto Body Co.**, 531 Caswell block, Milwaukee, will expend about \$80,000 in the construction and equipment of a frame and metal-working plant, four stories, 100 x 300 ft., of reinforced concrete, brick and steel.

**Mueck Auto Body Co.**, West Papin street, St. Louis, has been incorporated with a capital of \$30,000 to manufacture automobile pleasure and truck bodies, and wheels. Frank W. Mueck is president and W. Happell vice-president.

**Saginaw Auto Body Co.**, Saginaw, Mich., has started production operations with a capacity of 80 bodies a day, half of that number being built on a contract for one automobile maker. Alterations are being made to the plant.

**Appleton (Wis.) Auto Body Mfg. Co.** has broken ground for its new motor car, truck and closed body manufacturing plant at Spencer street and Pierce avenue. The company will spend about \$20,000 in the erection of buildings and wood and metal working equipment.

**Commercial Auto Body Co.**, St. Louis, Mo., has added 20,000 ft. of floor space to its factory by leasing a former garage building of the Entz Auto and Battery Co., at Nineteenth and Chestnut streets. This will become the finishing paint shop. The company has two other factories where bodies are built and primed.

**E. W. Goodwin** has become engineer of the body division of the Cadillac Motor Car Co., Detroit. Mr. Goodwin was in charge of the body division of the Chalmers Motor Co., for 1½ years, and has designed and superintended work for the Rothschild's American branch, the Holbrook Co., A. T. Demarest, Moore & Munger, G. W. Cole and others.

**C. R. Wilson Body Co.**, Bay City, Mich., is planning to erect an addition to its plant for the purpose of increasing its metal working department, at an expenditure of \$175,000. The company's new plant is now in operation. The main building is 300 x 300 ft., the dry storage building is 100 x 200 ft., the dry kilns are 50 x 200 ft., and the power house 50 x 91 ft.

### Car Builders

**Ford Motor Co.**, Detroit, will erect a four-story addition to Plant A.

**General Motors Co.**, Pontiac, Mich., will build 1,000 1½ ton chassis for the army signal corps to cost \$1,989 each.

**White Motor Co.**, Cleveland, has nearly completed a machine shop addition, 120 x 500 ft., at a cost of \$300,000.

**Olds Motor Works**, Lansing, Mich., is increasing its floor

space four acres by the erection of new buildings costing \$400,000.

**Chevrolet Motor Co.**, Detroit, in the first six months of 1917 sold 65,235 cars compared with 32,514 cars in the first half of 1916.

**Studebaker Corp.**, South Bend, Ind., has awarded the contract for construction of a power plant, 87 x 123 ft., to cost about \$100,000.

**Stutz Motor Car Co.**, Indianapolis, Ind., has been dissolved and is succeeded by the Stutz Motor Car Co. of America, Inc., with capital stock of \$1,125,000.

**Mutual Motors, Ltd.**, Hamilton, Ont., has been incorporated with a capital stock of \$25,000 by James M. McGill, Harry E. Phillips, William F. Roney and others, to manufacture automobiles, motors, etc.

**Doble-Detroit Steam Motors Co.**, Detroit, has leased for a period of five years a three-story and basement building, with 52,000 sq. ft., at Fourth and Porter streets, formerly occupied by the Boles Iron Works.

**Ford Motor Co.**, Detroit, is having plans prepared for the construction of a four-story reinforced concrete assembling plant on Newark Bay, Kearney, N. J. G. Plain-tiff, 1723 Broadway, New York, is manager.

**Chalmers Motor Co.**, Detroit, will be operated under the name it has borne for several years and not as a member of the Maxwell Motor Co., which recently took over the organization and plants of the Chalmers company.

**Fageol Motors Co.**, San Francisco, Cal., has completed the first unit of its new plant and will soon start manufacturing Fageol passenger cars, trucks and tractors. The plant is reported to be exceptionally complete in every detail.

**Liberty Motor Car Co. of Canada, Ltd.**, Windsor, Ont., has been incorporated with a capital stock of \$10,000, by Percy Owen, James F. Bourquin and Harland M. Wirth, all of Detroit, to manufacture motor cars, vehicles, accessories, etc.

**H. H. Franklin Mfg. Co.**, Syracuse, N. Y., plans a production schedule from September 1 for the manufacture of 1,000 Franklins a month for six months, the total of 6,000 cars comparing with 5,000 produced during the past six months.

**Chalmers Motor Corp.**, Detroit, has leased its plant to the Maxwell Motor Co. for five years to enable the working off of a large supply of materials. The Chalmers company proposes to issue \$3,150,000 first mortgage notes to meet old obligations.

**Lexington Motor Co.**, Connersville, Ind., manufacturer of motor-driven and other vehicles, has incorporated with \$1,800,000 capital stock. The directors are Andrew H. Rieman, Benjamin F. Thiebaud, Charles Cassell, E. Ralph Himelick and Allen Wiles.

**General Motors Co.**, Detroit, has completed plans for the construction of a new drop forge plant to cost about \$300,000, and consisting of three one-story buildings, 160 x 600 ft., 75 x 600 ft. and 65 x 300 ft. It is also arranging for the erection of a new plant in Flint, Mich.

**Essex Motors Co.**, Detroit, has been formed by members of the Hudson Motor Car organization, with a paid-in capital of \$500,000, and will build a car which will not compete with the Hudson models. W. J. McAneeny is president; R. B. Jackson, vice-president; A. Barit, treas-

urer, and J. L. Vette, secretary. Roy D. Chapin, president of the Hudson company, is on the board of directors.

**Comet Automobile Co.**, Decatur, Ill., has started the construction of its new plant which, when completed, will cost approximately \$140,000. The first unit will be 150 x 600 ft., running north and south along the Illinois Central and Vandalia railroads. It will be one story, of concrete and steel, while the front section will be two stories and will contain the administrative offices. An office building will also be erected south of the factory.

### Parts Makers

**Buda Co.**, Harvey, Ill., has started the construction of a manufacturing building, 80 x 260 ft.

**Edward F. Lyon Co.**, Detroit, has equipped its plant to manufacture axle shafts for automobiles.

**Baltimore Hub-Wheel Mfg. Co.** will make alterations and improvements in its plant to cost about \$3,500.

**Hess-Pontiac Spring and Axle Co.**, Pontiac, Mich., will construct two additional factory units within a short time.

**Jamestown (N. Y.) Auto Parts Mfg. Co.** is building a two-story addition to its plant on Steele street. Oscar Lanna is president.

**Doehler Die-Casting Co.**, Court and Ninth streets, Brooklyn, N. Y., has had plans prepared for a one-story addition, about 42 x 290 ft., to cost \$18,000.

**Victor Wire Wheel Co.**, Kalamazoo, Mich., which is being financed by the industrial committee of the Chamber of Commerce, has nearly completed a new plant.

**Jacob Gerhab Co.**, Philadelphia, has been incorporated

with a capital of \$167,000 to manufacture automobiles and parts. William Gerhab is the principal incorporator.

**Auto Radiator Co.**, Philadelphia, manufacturer of automobiles and parts, will erect a two-story brick and stone addition, about 30 x 80 ft., at its plant on Vine street.

**American Auto Trimming Co.**, Cleveland, O., has acquired a two-acre site adjoining its plant on East 72d street, and, it is reported, plans the erection of a factory addition.

**Hyatt Roller Bearing Co.**, Harrison, N. J., has acquired a foundry building, about 100 x 175 ft., on Somerset street, formerly occupied by Reuther Bros., iron founders. It will be used as a works extension.

**Grand Rapids (Mich.) Auto Products Co.** has been organized with a capital of \$10,000 to manufacture automobile parts. The stockholders are Harry C. Bennett, Robert J. Whyte, Christopher M. McCarthy and Arthur Post.

**W. H. Kelly**, formerly connected with the Bay City Body Co., and J. P. Friend are organizing a company in Bay City, Mich., for the manufacture of auto body covers. A portion of the Pioneer Boat Co.'s plant has been secured.

**Kelly-Springfield Tire Co.** is now installed in its splendid new quarters at 57th street and Seventh avenue, New York. The main floor of the new building is occupied as a store, while the general offices are located on the two floors above.

### PATENTS

**Patents**—H. W. T. Jenner, patent attorney and mechanical expert, 606 F St., Washington, D. C. Established 1883. I make a free examination and report if a patent can be had and exactly what it will cost. Send for circular.

**Leaders in their class for over three-quarters of a century**

**FABRICS**  
**BRIDGEPORT**  
**FABRICS**

**comprise an elegant assortment of the newest weaves, shades and patterns in automobile upholstery materials**

*WRITE FOR SAMPLES OF OUR*

**LIMOUSINE LININGS, CLOTHS, CARPETS, HORSE-HAIR CARPETS, CURTAIN SILKS, LACES, SEAT COVER FABRICS**

**We also supply ROBE RAILS, SPEAKING TUBES and TOILET CASES to match upholstery**

**BRIDGEPORT COACH LACE CO.**

**NEW YORK OFFICE, 1733 BROADWAY**

**BRIDGEPORT, CONN.**

# HOTEL ROCHESTER

Rochester, N. Y.



One of the Finest Equipped  
Hotels in the World  
EUROPEAN PLAN \$1.50 UP  
Club Features in Restaurant

MILTON ROBLEE, Manager

## Index To Advertisers

American Motors Corporation.....	4
Barrell Co., Wm. L.....	42
Bliss, E. W., Co.....	3
Bradley, C. C., & Son.....	45
Brennan Motor Mfg. Co.....	47
Bridgeport Coach Lace Co.....	37
Century-Plainfield Tire Co.....	39
Century Steel Co. of America, The.....	43
Columbus Bolt Works.....	Back cover
Cowles, C., & Co.....	44
Crane & MacMahon, Inc.....	Back cover
Decker, J. C.....	44
Dixon, Joseph, Crucible Co.....	9
Dowler, Chas. L.....	44
Doxey, N. D.....	40
DuPont Fabrikoid Co.....	42
Eberhard Mfg. Co., The.....	10
Eccles, Richard, Co.....	46
Empire Art Metal Co., Inc., The.....	8
G & O Mfg. Co.....	47
Gray, Peter, & Sons, Inc.....	45
Hartford Auto Parts Co.....	3
Hoopes Bro. & Darlington.....	47
Hotel Brunswick.....	45
Hotel Rochester.....	38
Hotel Tuller.....	40
Johnston, R. F., Paint Co.....	44
Judd & Leland Mfg. Co.....	11
Keratol Co., The.....	42
Laidlaw Co., The.....	2
Lumen Bearing Co.....	41
Mulholland Co., The.....	44
Norton Grinding Co.....	5
Parrott Varnish Co., The.....	2
Pettingell Machine Co.....	7
Pierce, F. O., Co.....	43
Pittsfield Spark Coil Co.....	41
Porter, H. K.....	45
Poughkeepsie Utilities Corp.....	40
Pressed Steel Co.....	2
Quickwork Co., The.....	45
Rome-Turney Radiator Co.....	46
Rubber Insulated Metals Corporation.....	39
Russell, Burdsall & Ward Bolt & Nut Co.....	45
Sheldon Axle & Spring Co.....	12
Simmons Machine Co., Inc.....	40
Standard Oil Cloth Co., Inc.....	6
Wayne Wheel Co.....	2
West Tire Setter Co.....	47
White-Quehl Mfg. Co.....	44
Wilcox Mfg. Co., D.....	47
Wiley Co., C. A.....	46
Williams, J. H., & Co.....	Front cover
Wing, Chas., Co.....	44
Yoder Company, The.....	Back cover

## Vehicle Mechanics

Desiring to improve their present  
Condition should attend the

## TECHNICAL SCHOOL

For

## Automobile Draftsmen and Mechanics

Supported by the

The National Automobile Chamber of Commerce, Inc.

The object of the School is to teach men to design vehicles and make working drawings, and to otherwise facilitate their work in the shop. Only those men employed in carriage or automobile building or their accessory trades are admitted to its privileges.

The classes are conducted in three divisions, viz.: Corresponding, Day, and Evening. The former is open during the entire year, while the day and evening classes are in session only from October 1 to April 1.

The tuition is moderate.

For prospectus and full particulars, write to the instructor,

ANDREW F. JOHNSON,  
20 West Forty-fourth St.,  
NEW YORK CITY





# Superbar Tires

"Service Tires"

Made of high grade fabric and best grades of pure rubber to meet the demand of those who seek a good Standard Quality Tire giving maximum amount of service for money invested.

Built by HAND throughout.

SUPERBAR Tires are the result of many years of scientific experimenting and combine quality of material, skill in workmanship and a maximum of road resistance.

Adjusted on 3,500-mile basis. Ford sizes, 4,500-mile basis.

Splendid agency opportunities are available; particulars on request.

## Century-Plainfield Tire Co.

Plainfield, N. J.

Century-Plainfield Tire Company, a subsidiary of the Rubber Metals Corporation, exclusive manufacturers of the Rimco Rubber Products by the Elchemco process

# "RIMCO" INSULATED PLIERS

**H**ERETOFORE efforts made by plier manufacturers to put out insulated pliers have been with pliers which had no practical value, in the sense that they would not take either a high insulation or stand rough practical usage, which a lineman is compelled to give a tool of this character. We are now marketing a plier which is of very high standard, and will fill all the requirements of a lineman and give universal satisfaction to him in his work.

The plier itself is of the best and finest

The method of putting on the rubber insulation is one covered thoroughly by American and foreign patents, and has no equal, in the sense that this patent—the Elchemco Process—is the only method of its kind known whereby rubber can be attached to metal without its being purely a mechanical attachment. It therefore means that the bond of the rubber to the metal is of such a character that there can be no chance of it not being secure. On the contrary, it is so firmly held to the metal that repeated

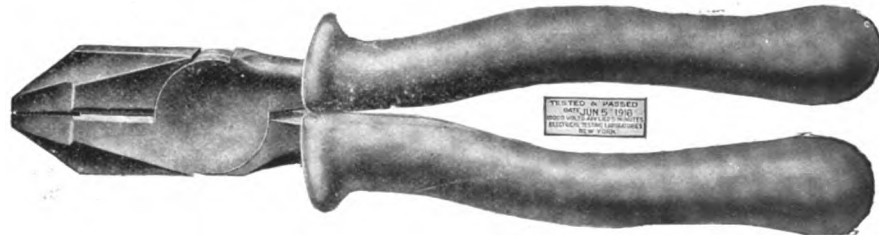

grade of tool steel, with an insulated rubber compound of high grade material, made to withstand high voltage test and also to give definite, practical service to the user.

Bears the stamp of approval of the Electrical Testing Laboratories, Inc., of New York City, which stamp on each individual plier shows that it has been tested and passed for 10,000 volts.

experiments of a high technical character have failed to show any "breakdown" when once the rubber has been applied to the handles.

This plier can not only be sold for a lineman's plier, but can also be used as part of the equipment on automobile trucks and automobiles, as well as being used by those working about high voltage equipment.

## Rubber Insulated Metals Corporation

Plainfield

New Jersey

Please mention The Hub when you write



# ANCHOR WELDING COMPOUND

MANUFACTURED BY  
**N. D. DOXEY, ELMIRA, N. Y.**

ANCHOR WELDING COMPOUND will weld hardest steel. Will not peel apart at the weld, thus losing the heat, nor burn up when flowing on the lap. Will weld without the use of hammer. Place two flat surfaces together in the fire, smelting the Compound liberally on the parts and press pieces together firmly with tongs, and weld will be complete without a stroke of the hammer. It will not require any iron filings to be added in welding as in some other compounds. It does the work itself. A weld made with ANCHOR COMPOUND leaves the welded parts of equal strength with solid parts of the metal. Cannot be damaged by dampness nor by heat.

Your Welding Compound gives entire satisfaction. In welding steel of high carbon, it fluxes quick and the steel appears like iron, and can be worked at a white heat. I have tried all other compounds in the market and can pronounce yours the best. It flows where you want it to flow.

C. H. KILMER, Elmira, N. Y.  
We take pleasure in stating that we have been using your Welding Compound for several years and find it a most excellent article, and can recommend it highly. Yours truly,  
THE LAFRANCE FIRE ENGINE CO.,  
W. Falck, Gen. Manager, Elmira, N. Y.

Is used by U. S. Navy and C. & N. W. Ry. Co. and many others.

IN USING do not throw the Compound from the surface to be welded, but cup the scarf, and in light work turn the piece, when ready for welding, so that the Compound will flow evenly over the surface to be welded, which it will readily do, flowing like oil. In heavier work, add compound to surface to be welded, as heat nears welding point, so that surface to be welded is covered with fused compound.

**DO YOU HEAR** GO AHEAD  
the UTILITY KID signaling  
you to go ahead and get  
**UTILITY VARNISH RENOVATOR**



## THIS is a NECESSITY not a luxury

Because if you are particular about the appearance of your automobile in WINTER, you'll need "UTILITY." It's no joke to clean your car in cold weather the "old way." You require a multitude of tools—sponge, hose, boots, etc., and you have a COLD, unpleasant job. Why not

Avoid that old-time dirty mess—  
You can clean your car in evening dress  
with cheese cloth and a can of

## Utility Varnish Renovator

Remove the water spots from your car.  
Cover up blemishes caused by flying ice and sleet.  
Dissolve and remove mud absolutely without scratching the varnish.

**Dealers** Why not be prepared to give your customer that which he will need? Our special offer sent on request.

- List Prices:  
4 ounce bottles, 25c      Quart cans, \$1.00  
12 ounce bottles, 50c      Gallon cans, 3.00  
Sprayer, 25c

## Poughkeepsie Utilities Corporation,

44 WINNIKEE AVENUE, POUGHKEEPSIE, N. Y.



Meet me at the Tuller for Value, Service, Home Comforts

## NEW HOTEL TULLER Detroit, Michigan

Center of business on Grand Circus Park. Take Woodward car, get off at Adams Avenue.

ABSOLUTELY FIREPROOF

200 Rooms, Private Bath,	\$1.50	Single,	\$3.00	Up Double
200 " " "	2.00	" " "	4.00	" "
100 " " "	2.50	" " "	4.50	" "
100 " " "	3.50 to 5.00	" " "	5.00	" "

Total, 600 Outside Rooms

ALL ABSOLUTELY QUIET

Two Floors—Agents' Sample Rooms

## Here's the Evidence—

that should impel you to investigate the case of the

## Premier Universal Tool and Cutter Grinder

It has massive table, micrometer adjustments, very long knee and gibs, and extra heavy head and tailstock.

Headstock is fitted with large bearing for chuck spindle and with special bronze bearings of navy specifications; spindle is tapered and bored to take wheel arbors, and bearings are 1 in. in diameter and 2 1/4 in. long; exceptionally simple and sturdy countershaft, and has self-lubricating bearings.

We'll help along your investigation—write for the details TODAY.

## Simmons Machine Co., Inc.

1001 Singer Bldg.,  
NEW YORK CITY  
981 Broadway,  
ALBANY N. Y.  
358 Ellcott Square  
BUFFALO N. Y.

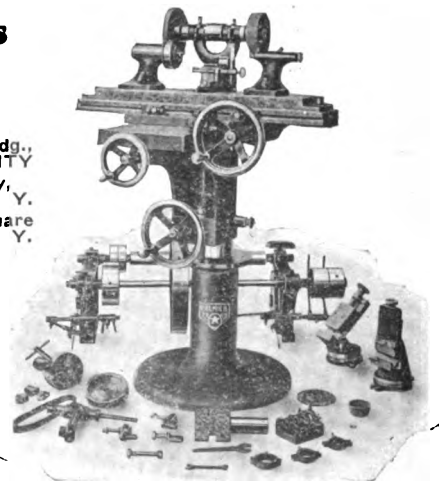

Please mention "The Hub" when you write

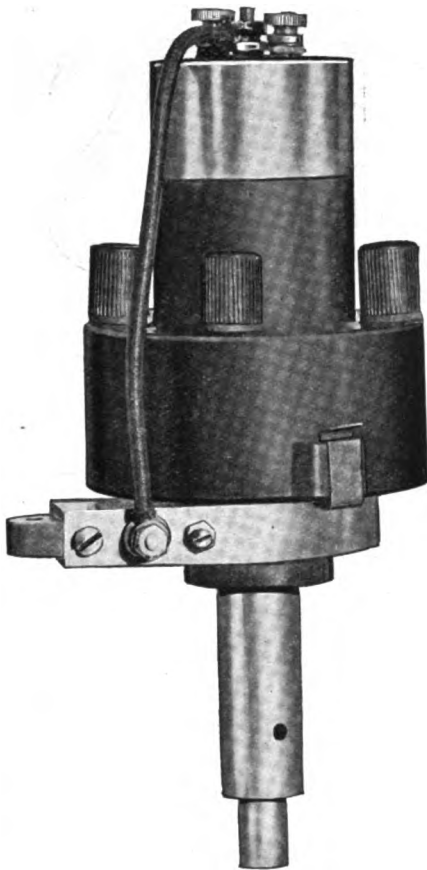

## A Perfectly Synchronized Spark at ALL Speeds

"Pittsfield" Distributor is of unit construction. It has an absolutely mechanical make and break which is positive and independent of spring action. No trips, hammers or other unreliable devices are required or used.

Its make and break is positive, giving a perfectly synchronized spark at all speeds. There is no lag in the spark—no automatic advances required.

Send for folder fully describing the "Pittsfield"

### FORD OWNERS

We have developed a special bracket for installing the "Pittsfield" Distributor on Ford Cars. Send for Folder.

Also manufacturers of "Pittsfield" Coils, Timers, Switches, "Berkshire," "Jewell," and "Micatite" Spark Plugs.

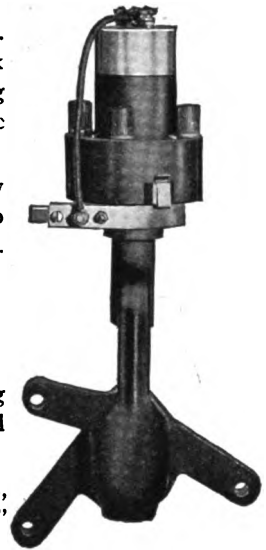

## PITTSFIELD SPARK COIL CO.

PITTSFIELD, MASS.

# MACHINEBRONZE

THE UNIVERSAL  
BEARING BRONZE

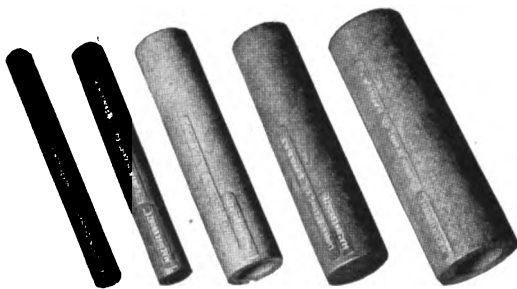

Carried in stock in solid and cored bars of 12" lengths—  
1/8" to 4 1/2" diameter, inclusive, by 1/8ths

Are Your Machines  
*Making* Money, or  
*Costing* Money?

Are your machines running steadily and MAKING money, or are they continually "down" for repairs and thus COSTING money?

If they are "down," worn bearings is probably the cause, as is the case nine out of ten times.

If you put cheap bearings in those machines that are "down," you'll no doubt have them "down" again in a short while.

It always pays to build them up with the best bearings you can buy. Bearings made of Machinebronze will cost you a little more, but consider the future shutdowns and overhauls they will save you.

You will be interested in our booklets.  
Send for them today

## LUMEN BEARING COMPANY

BRASS FOUNDERS

BUFFALO

Please mention "The Hub" when you write

# Keritol LEATHER SKINS

For the car where leather has always been used



PRICE

*Within Reason*

QUALITY

*Maintained*

W<sup>m</sup> L. BARRELL Co. 8 THOMAS ST.  
NEW YORK

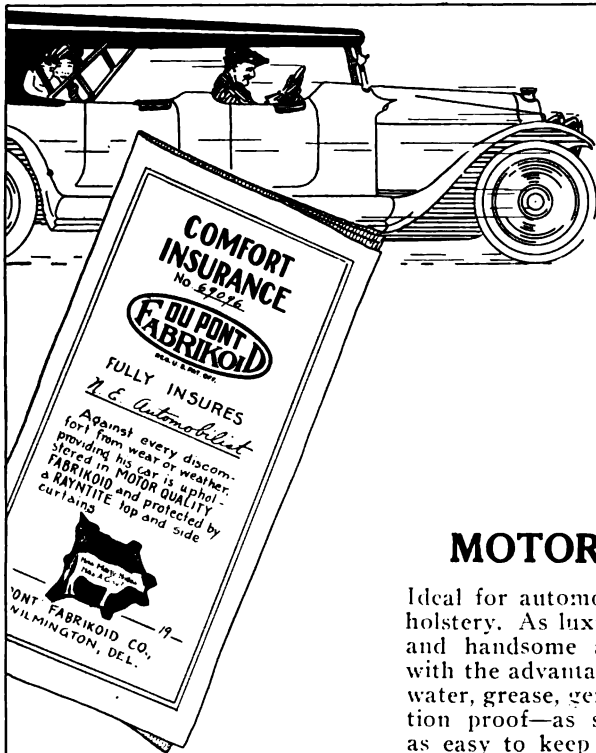

## Comfort Insurance Is Free

You pay for Fire Insurance.  
You pay for Accident Insurance.  
Comfort Insurance is a matter of  
policy in selecting



REG. U. S. PAT. OFF.

The Best Leather Substitute

**MOTOR QUALITY**

Ideal for automobile and carriage upholstery. As luxurious, soft, satisfying and handsome as the finest leather, with the advantage of being absolutely water, grease, germ, stain and perspiration proof—as sanitary as glass and as easy to keep clean.

**RAYNTITE**

The safest material to use for tops and side curtains on automobiles, boats and carriages. Gives absolute protection, unequaled beauty and serviceability. Guaranteed not to leak, crack or peel for one year—built to last the life of the car.

Write for Samples and Booklet

**DU PONT FABRIKOID CO. WILMINGTON, DEL.**

Please mention "The Hub" when you write.

# F. O. PIERCE COMPANY

## NEW YORK, U. S. A.

Manufacturers of High Class Pigment Colors

### FOR AUTOMOBILE PAINTING

Made from ORIGINAL FORMULAE.  
 Colors ground in Japan and other MEDIUMS  
 to meet any SYSTEM of APPLICATION

We can now supply Uzatona in Japan, Oil or Varnish. Prices upon application

## One of the Steels of the Century Centurion High-Speed

Made from the **BEST** Materials  
 Consequently  
 Will do the **BEST** Work

*Quality*

*Delivery*

*Service*

*We have a catalog waiting for you. Write for it.*

### THE CENTURY STEEL CO. OF AMERICA

Manufacturers of High-Grade Crucible Steels

General Office and Works:  
 POUGHKEEPSIE,  
 N. Y.

Sales Office:  
 120 BROADWAY,  
 NEW YORK

Please mention The Hub when you write

## BUSY BUYERS BRIEFS

### JOHNSTON'S KRAKNO

Color Card Free  
\$3.50 per gallon

The R. F. Johnston Paint Co.  
Cincinnati, Ohio

### THE CHARLES WING CO

Established 1848

Manufacturers and Wholesale Dealers in  
**AUTOMOBILE AND CARRIAGE  
HARDWARE AND TRIMMINGS**  
AMESBURY, MASS., U. S. A.

### Why Not Have the Best?

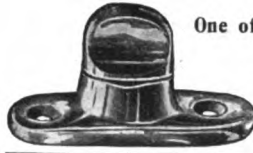

One of a Large Variety

G. Cowles & Co.  
NEW HAVEN,  
CONN.

### J. C. DECKER

MONTGOMERY, PA.

Manufacturer of

### Carriage, Skate and Pad Straps

Side Loops, Bridle Fronts, Tail Ties, etc.

### CHARLES L. DOWLER

CARRIAGE AND WAGON HARDWARE

108 North Third St., Philadelphia, Pa.

### CUSHION MANUFACTURER

Pure Stearic Acid Candles. Wheel Stock. Snow  
Flake Axle Grease.

### MULHOLLAND BUGGY SPRING

Reduces weight of springs one-half.  
Made in one size only but will fit bodies  
of all widths.

Write for further particulars and prices.  
THE MULHOLLAND CO. DUNKIRK, N. Y.



LINED



UNLINED

### White's Brazing Sleeves

For applying Rubber Tires  
Send for Samples.

WHITE-QUEHL MFG. CO.

431 E. Pearl St.  
CINCINNATI, OHIO

## CLASSIFIED INDEX

For Addresses See Alphabetical Index  
and Advertising Pages

### AUTOMOBILES

American Motors Corp., Plain-  
field, N. J.

### AUTO FABRICS

Barrell, Wm. L., Co., New York  
Keratol Co., The, Newark, N. J.  
Laidlaw Co., Inc., The, New  
York  
Standard Oil Cloth Co., New  
York City.

### AUTO PARTS

Hartford Auto Parts Co., Hart-  
ford, Conn.

### AXLES (Including Ball and Roller Bearing)

Sheldon Axle & Spring Co.,  
Wilkes-Barre, Pa.

### BOLTS AND NUTS

Columbus (O.) Bolt Works Co.  
Russell, Burdall & Ward Bolt  
& Nut Co., Port Chester, N.Y.

### BOLT CLIPPERS

Porter, H. K., Everett, Mass.

### BRAZING SLEEVES

White-Quehl Mfg. Co. Cincin-  
nati, O.

### BRONZE BEARINGS

Lumen Bearing Co., Buffalo.

### DIES

Bliss Co., E. W., Brooklyn, N.Y.  
(Sheet Metal Working).

### FORGINGS

Eccles, Richard, Auburn, N. Y.  
(Carriage, Drop).  
Williams, J. H., & Co. Brook-  
lyn, N.Y. (Automobile, Drop)

### FIFTH WHEELS

Wilcox Mfg. Co., D., Mechanics-  
burg, Pa.

### HARDWARE (Carriage, Wagon and Automobile)

Columbus (O.) Bolt Works Co.  
Dowler, Chas. L., Philadelphia.  
Eccles Co., Richard, Auburn,  
N. Y.  
Wilcox Mfg. Co., D., Mechan-  
icsburg, Pa.  
Wing Co., Chas., Amesbury,  
Mass.  
Cowles, C., & Co., New Haven,  
Conn.

### LEATHER SUBSTITUTES

Barrell Co., Wm. L., New York.  
Keratol Co., The, Newark, N. J.  
Standard Oil Cloth Co., New  
York.  
DuPont Fabrikoid Co., Will-  
mington, Del.

### LUBRICANTS

Dixon, Jos., Crucible Co., Jer-  
sey City, N. J.

### MACHINERY AND TOOLS

Bliss Co., E. W., Brooklyn, N.Y.  
Norton Grinding Co., Worces-  
ter, Mass.  
Pettingell Machine Co., Ames-  
bury, Mass.  
Simmons Machine Co., Inc.,  
Albany, N. Y.; Singer Bldg.,  
New York City.  
Smith, H. Collier, Detroit, Mich.  
West Tire Setter Co., Roches-  
ter, N. Y.  
Williams, J. H., & Co., Brook-  
lyn, N. Y.  
White-Quehl Mfg. Co., Cincin-  
nati, O.  
Yoder Co., The, Cleveland, O.

### MACHINERY (Metal Working)

Bliss Co., E. W., Brooklyn, N.Y.  
Pettingell Machine Co., Ames-  
bury, Mass.  
Quickwork Company, Detroit,  
Mich.  
Yoder Co., The, Cleveland, O.

### MAGNETOS

Berkshire Magneto Co., Pitts-  
field, Mass.

### METAL STAMPINGS AND NOVELTIES

Gray, Peter, & Sons, Inc., Cam-  
bridge, Mass.  
Pressed Steel Co. of New York,  
New York City.

### MOTORS

Brennan Motor Mfg. Co. Syra-  
cuse, N. Y.

### PATENTS

Jenner, H. W. T., Washington,  
D. C.

### PAINTS AND COLORS

Johnston Paint Co., R. F., Cin-  
cinnati, O.  
Pierce Co., F. O., New York.  
Willey Co., C. A., Hunter's  
Point, N. Y.

### PRESSES

Bliss Co., E. W., Brooklyn, N.Y.  
(Drop, Power).

### RADIATORS

G. & O. Mfg. Co., New Haven,  
Conn.  
Rome-Turney Co., Rome, N. Y.

### SCHOOL FOR DRAUGHTS- MEN

Mechanics' Institute, New York

### SHAFT COUPLINGS

Bradley & Son, C. C., Syracuse,  
N. Y.  
Eccles Co., Richard, Auburn,  
N. Y.

### SPARK COILS

Pittsfield Spark Coil Co., Pitts-  
field, Mass.

### SPRINGS

Mulholland Co., Dunkirk, N. Y.  
Sheldon Axle & Spring Co.,  
Wilkes-Barre, Pa.

### STEEL

Century Steel Co. of America,  
Poughkeepsie, N. Y.; Sales  
office, 120 Broadway, N. Y.

### TIRES

Century-Plainfield Tire Co.,  
Plainfield, N. J.

### TIRE PUMPS

Judd & Leland Mfg. Co., Clifton  
Springs, N. Y.

### TOOLS

Williams, J. H., & Co. Brook-  
lyn, N. Y.

### TRIMMING MATERIAL

Bridgeport (Conn.) Coach Lace  
Co.  
Decker, J. C., Montgomery, Pa.  
Wing Co., Chas., Amesbury,  
Mass.

### UNIVERSAL JOINTS

Hartford (Conn.) Auto Parts  
Co.

### VARNISH AND JAPAN

Parrott Varnish Co., Bridgeport,  
Conn.  
Pierce Co., F. O., New York.  
Willey Co., C. A., Hunter's  
Point, N. Y.

### VARNISH RENOVATOR

Poughkeepsie (N. Y.) Utilities  
Corp.

### WHEELS

Crane & MacMahon, Inc., New  
York City.  
Hoopes Bros. & Darlington,  
Inc., West Chester, Pa.  
Wayne Wheel Co., Newark, N.J.

### WOOD BENDINGS, WHEEL STOCK, ETC.

Crane & MacMahon, Inc., New  
York City.

Please mention "The Hub" when you write





The Only  
One-piece  
Moulded  
Leather Packing

## The Bradley Carriage Coupler

*All-Steel    Noiseless    Quick-Shifting    Ball-Bearing*

(MADE IN FIVE SIZES FOR  
AXLES  $\frac{3}{4}$  INCH TO  $2\frac{1}{4}$  INCH)

The *only* carriage coupler that is  
furnished with a **ONE-PIECE  
MOULDED LEATHER PACKING**

**C. C. BRADLEY & SON, Syracuse, N. Y.**



The Bradley  
Carriage Coupler

## THE BRUNSWICK



**Boylston Street, Corner Clarendon,**  
(Facing Copley Square)

**BOSTON - - MASS.**

High class modern house, intelligent service,  
pleasant rooms, superior cuisine.

Ladies traveling alone are assured courteous attention

European plan, single rooms, \$1.50 up; with bath,  
\$2 up; double, \$2 up; with bath, \$3 up.

American plan; \$4 per day up.

**FRED E. JONES - Proprietor**

## Sheet Metal Specialties



**WE** are in a position to furnish *Sheet  
Metal Stampings* in all kinds of  
metal at the rate of several hundred  
thousand pieces per day.

Special attention given to rush orders.  
Send us your inquiry with specifications.

**Peter Gray & Sons, Inc.**  
Cambridge, Mass.

**“Quickwork”**      Sheet Metal  
Working Machinery

For Automobile and Carriage Bodies, Fenders, Hoods, etc.

**THE QUICKWORK CO.**

H. COLLIER SMITH, Pres. and Gen. Mgr. ST. MARYS, O.

**PORTER'S BOLT CLIPPERS**  
“Easy” “New Easy” Allen-Randall



To Cut 5-16, 3-8, 1-2, 5-8, 3-4 Inch.

**H. K. PORTER, EVERETT, MASS.**

## RUSSELL, BURDSALL & WARD BOLT & NUT CO.

Established 1845      PORT CHESTER, N. Y.

**MAKERS OF THE CELEBRATED EMPIRE BOLTS AND NUTS**

Western Office: Continental & Commercial Bank Bldg., Chicago, Ill. Branch Works: Rock Falls, Ill.

Please mention “The Hub” when you write

# RADIATOR INSURANCE

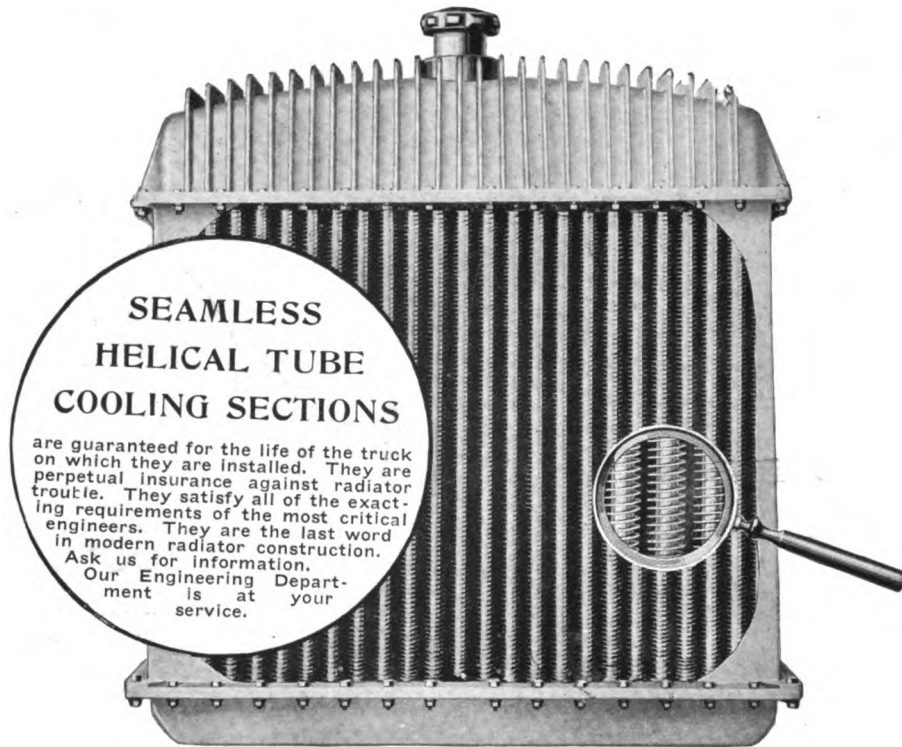

ROME-TURNEY RADIATOR CO., Sole Manufacturers, ROME, N. Y.

## WILLEY'S COLORS

The Recognized Standard



**C. A. WILLEY CO.**

**COLOR GRINDERS**

and Manufacturers of Specialties in

**CARRIAGE, AUTOMOBILE and CAR**

**PAINTS**

**COLORS, VARNISHES, ETC.**

**HUNTER'S POINT, NEW YORK CITY**

## Automobile, Carriage, Wagon and Special FORGINGS

of Guaranteed Quality

When you are in the market, send us your blue-prints for quotations.

Ask for catalog showing part of our large line of Automobile and Special Forgings, also catalog listing our full line of Carriage and Wagon Hardware.

**Richard Eccles Co.**

**AUBURN, NEW YORK**

ESTABLISHED IN 1880

Please mention "The Hub" when you write

# HOOPES BRO. & DARLINGTON

(INCORPORATED)

WEST CHESTER, PA.

WE ARE MAKING

# AUTOMOBILE WHEELS

Forty Years' Experience as WHEEL MAKERS is guarantee we can make good ones.  
Will not make any other kind. Try them.



ENGINE COOLING

## RADIATORS

FOR PLEASURE CAR AND HEAVY DUTY SERVICE

G & O MFG. CO. - New Haven, Conn.

# WILCOX

FINE  
FINISHED  
FORGED

CARRIAGE HARDWARE  
AND GEAR IRONS

Write for Prices and Catalog

The D. Wilcox Mfg. Co.

MECHANICSBURG, PA.

## The WEST Hydraulic Tire Setter

WILL CUT DOWN EXPENSE

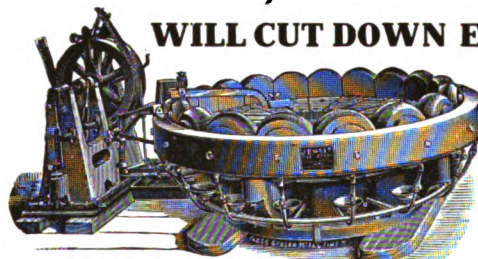

Tires set cold in one minute. This machine saves time—does the work better and quicker, does a way with burned streaks. Only necessary to measure one wheel in a lot. Does not char the rim, and

thus make the tire loosen prematurely. Saves resandpapering of wheels. This machine is now increasing the profits of many manufacturers. Send for catalog and read about it.

WEST TIRE SETTER CO., ROCHESTER, NEW YORK

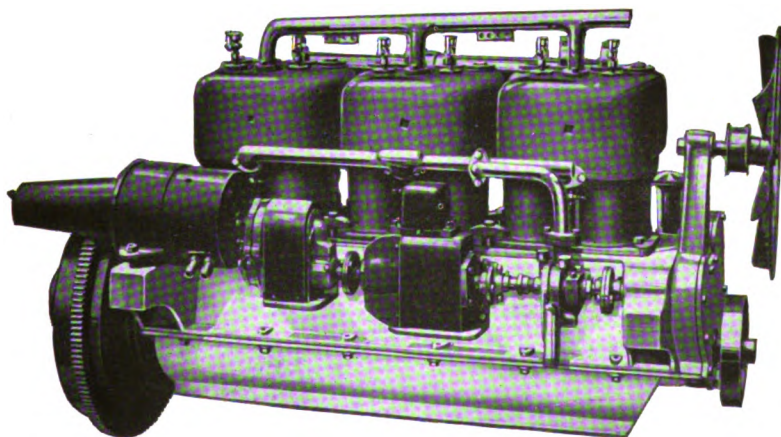

Model 6B Motor, 4½" bore by 5" stroke

Please mention "The Hub" when you write

## Quality and Service

are the two essentials that for 17 years have been built into

# BRENNAN STANDARD MOTORS

The manufacturer of Commercial or Pleasure cars who equips his product with Brennan Standard Motors can feel assured his every requirement regarding this vital part has been fulfilled.

Built in the following sizes:  
4 Cylinder Model M—4 x 5    4 Cylinder Model 12—5½ x 6  
4 Cylinder Model B—4½ x 5    4 Cylinder Model 12—6 x 6  
4 Cylinder Model 11—5 x 5    6 Cylinder Model 6B—4½ x 6

Let us send bulletins telling WHY Brennan Motors are STANDARD motors

Brennan Motor Mfg. Co., Syracuse, N. Y.



## The Hub

### AUTO TRUCK

Hickory Nut and

BEST QUALITY STOCK  
TOUGH AND HEAVY

BONE DRY

MANUFACTURED BY  
CAPABLE MECHANICS  
AND MOST  
IMPROVED MACHINERY

WHEELS WHICH ADD TO  
THE LIFE OF YOUR TRUCK

ST. MARY S, OHIO

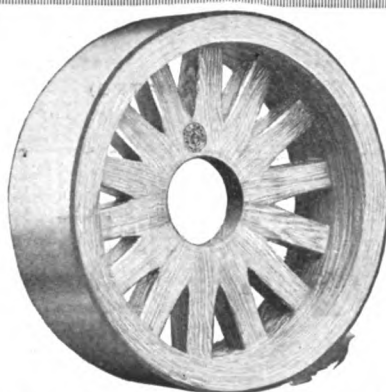

### WHEELS

Acorn Brands

HORSE-DRAWN  
VEHICLE WHEELS  
ALL STYLES

TRAILER WHEELS:  
SARVEN AND  
ARTILLERY TYPES

HIGH STANDARD OF  
QUALITY AND  
WORKMANSHIP  
MAINTAINED

CRANE & MacMAHON, Inc.

8 BRIDGE ST., N. Y. CITY

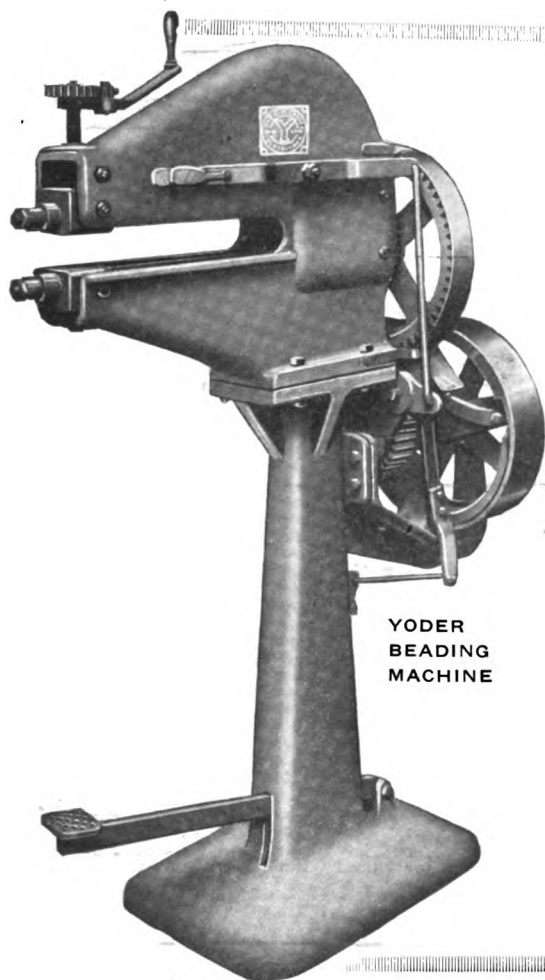

YODER  
BEADING  
MACHINE

## Yoder Sheet Metal Machinery

Our line of Auto Sheet Metal Working Machinery is efficient in every detail.

Every machine is constructed with the objective of producing perfect results at a minimum cost of material and labor.

The Yoder Company guarantees its machinery to produce results satisfactory to the purchaser.

We are glad to consider your Sheet Metal Machinery needs, as well as your requirements for special machines.

If you are thinking of making your own sheet metal parts or producing sheet metal products for the trade, get in touch with us at once. We can save you money and furnish a most satisfactory and complete equipment.

Catalog and prices furnished on request

## THE YODER COMPANY

Engineers Building

CLEVELAND - - - OHIO

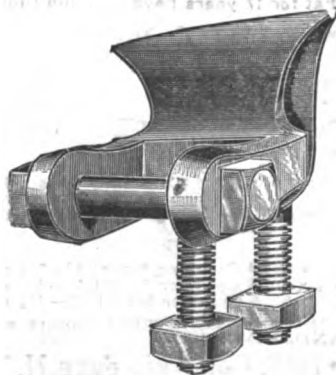

### Skewed Shaft Couplings

**Regular or Oval Patterns  
For High Arched Axles**

Furnished in rights and lefts for any height of arch.  
Oval Axle Clips  $\frac{5}{8}$  or  $\frac{3}{4}$  width to match Oval  
Couplings. Bolts, Clips, Couplings, Carriage  
Hardware and Special Forgings

Catalogue "H" and Prices on Application

**COLUMBUS BOLT WORKS COMPANY**

COLUMBUS, OHIO

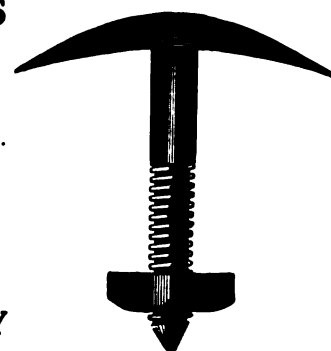

# The Hub

First Journal of the Vehicle Industry

Vol. LIX

NEW YORK, NOVEMBER, 1917

No. 8

*From The  
Automobile  
May 31, 1917*

TESTS made with a U. S. floating power plant truck to demonstrate its non-skidding qualities are said to have brought out some interesting facts regarding the brake equalizer.

The truck in three trials was brought to a full stop on a street in Cincinnati, the first time, 1, with a 3½-ton load in 19 ft.; the second time, 2, with a 4½-ton load in 18 ft., and the third time, 3, empty in 24 ft. On each occasion the truck was halted in less than its own length. An interesting feature, which is clearly illustrated in the photograph by the marks on the right, is the fact that while empty the truck actually hopped along on and off the pavement when the brakes were violently applied. The tests were conducted by E. C. Shumard, chief engineer of the United States Motor Truck Co., Cincinnati.



## -And They Did It with a SHELDON W-30° Worm Gear Axle

THE TEST SHOWN ABOVE is a convincing demonstration not only of the perfect control the driver has at all times over a U. S. truck by means of the positive brake equalizer, but also of the care with which the U. S. Motor Truck Co.'s engineers have selected their rear axle and brake equipment.

ENGINEERS OF MOTOR TRUCKS who are building such service as this into their trucks select their axles and brake equipment on the basis of superiority, not price.

SHELDON WORM GEAR AXLES are a part of U. S. trucks because they are the best axles built.

JUST ONE INSTANCE of the superiority of Sheldon Semi-Floating Worm Gear Axles over all other types is this question of brakes.

SHELDON BRAKES are double internal expanding, with generous wearing surfaces, and enclosed to keep out mud and grit. This minimizes wear and, of course, adds immeasurably to the life of the truck.

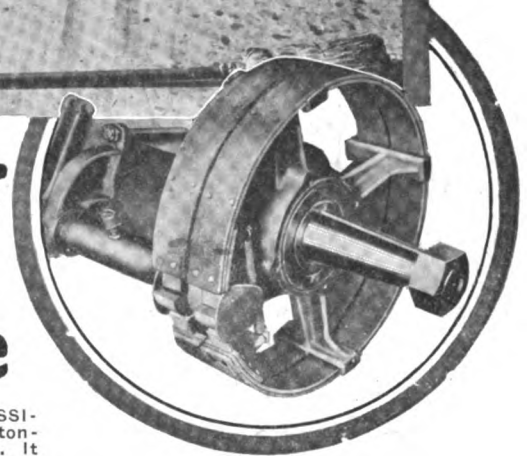

THEIR ACCESSIBILITY is astonishingly simple. It is not necessary to remove the wheels for adjusting the tension. Simplicity makes for strength, but such simplicity as Sheldon's is the result of years of designing, rejecting, perfecting.

SHELDON AXLES are designed and manufactured to an ideal—strength, safety, accessibility. This means longer life and better service to the truck.

LOOK FOR the Sheldon shop mark—the double anchor—on the worm carrier and the hub caps.

**SHELDON AXLE & SPRING CO.**

Makers of Springs and Axles for Heavy Duty Service for More Than Fifty Years

WILKES-BARRE

PENNA.

# PARROTT VARNISHES



.. Unequaled for ..

**Automobile  
and  
Carriage  
Finishing**

**The Parrott Varnish Co.**  
Bridgeport, Conn.

# AUTOMOBILE WHEELS

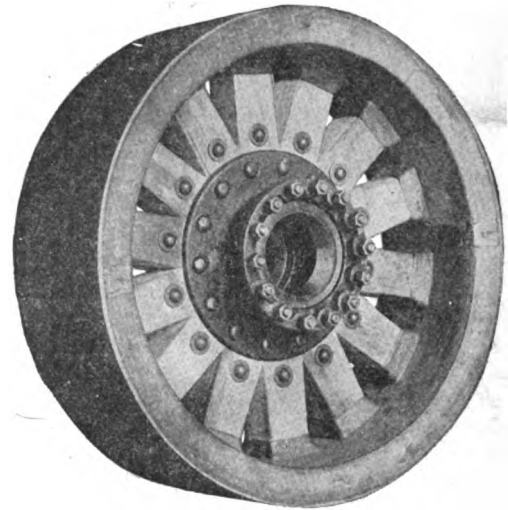

Have you seen our *new* construction?  
Better write us for particulars.

**Wayne Wheel Co.**  
Newark, Wayne Co., New York

# steel stampings

*especially for*  
**COMMERCIAL TRUCKS**

**The Pressed Steel Company**  
Wilkes-Barre, Pa.

# The Laidlaw Company Inc.

New York City

: : : : : :

**Automobile  
Fabrics**

: : : : : :

**A Fabric for  
Every Purpose  
For Closed, Open or  
Convertible Bodies**



# A sure way to reduce your costs!

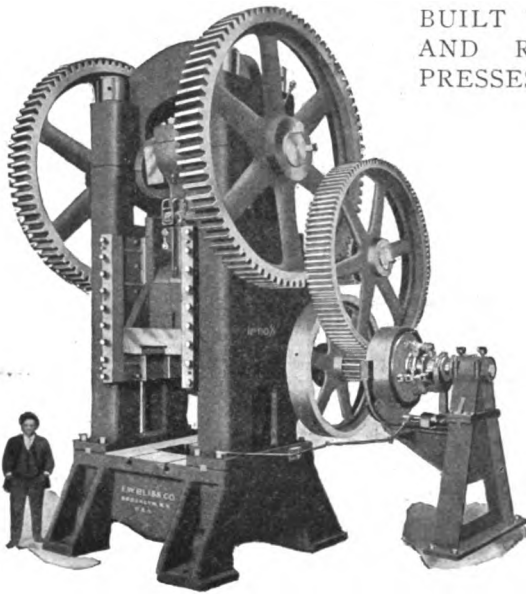

"Bliss" No. 80½ Straight Side Press  
Weight, 175,000 Pounds

BUILT WITH THE GREATEST POSSIBLE STRENGTH AND RIGIDITY, BLISS STRAIGHT-SIDE POWER PRESSES MINIMIZE THE MAINTENANCE COST OF BOTH MACHINE AND TOOLS.

## Bliss Straight-Side POWER PRESSES

are being widely used for heavy punching, piercing, shaping, stamping and drawing operations in the manufacture of automobile parts, agricultural implements, electrical instruments, cutlery and heavy hardware. They are also adapted for trimming drop forgings, hot or cold.

Built in various sizes ranging in weight from 5,000 to 175,000 pounds.

**We are anxious to send you full details.**

Let us know your requirements and we'll be glad to offer you a few valuable suggestions. **Write us at once.**

### E. W. BLISS CO.

38 ADAMS ST., BROOKLYN, N. Y., U. S. A.

Chicago Office: Peoples Gas Building

Detroit Office: Dime Bank Building

Cleveland Office: Union Bank Building

Offices in Europe: 100 Boulevard Victor-Hugo, St. Ouen,  
Paris; Pocock St., Blackfriars Road, London, S. E.



## Hartford Universal Joints

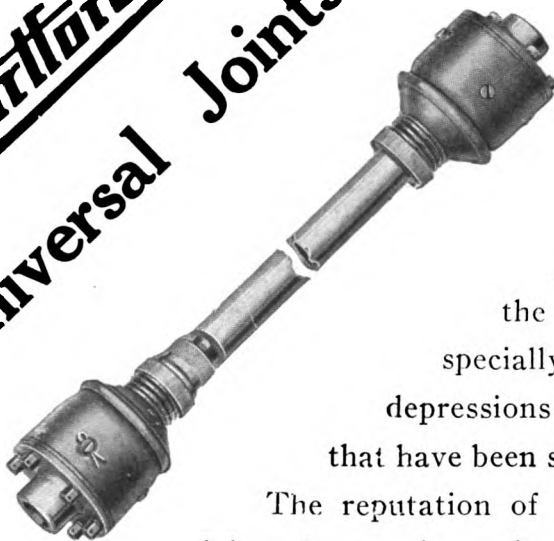

WE are able to offer manufacturers universal joints manufactured by specialists in one of the largest plants in the world.

The wearing surfaces of HARTFORD UNIVERSAL JOINTS are hardened and ground, the grinding being accomplished by a specially devised machine whose use eliminates depressions or elevations so common in steel parts that have been simply reamed.

The reputation of your car demands the best universal joints that can be made, and we have them.

## The Hartford Automobile Parts Co.

Established 1906

Hartford, Conn.

Please mention "The Hub" when you write.

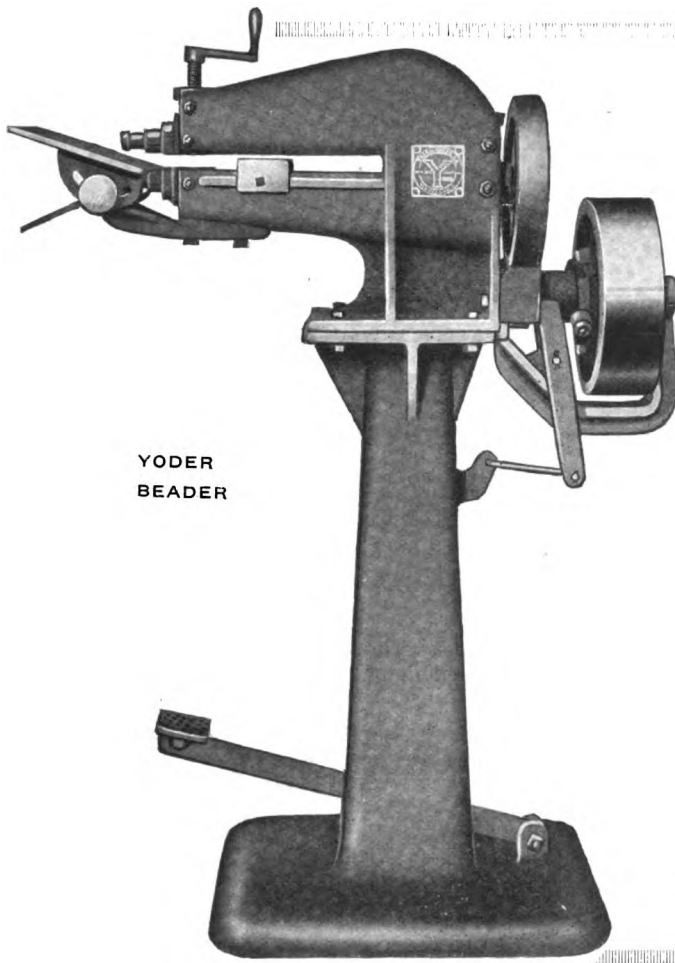

YODER  
BEADER

## Yoder Sheet Metal Machinery

Our line of Auto Sheet Metal Working Machinery is efficient in every detail.

Every machine is constructed with the objective of producing perfect results at a minimum cost of material and labor.

The Yoder Company guarantees its machinery to produce results satisfactory to the purchaser.

We are glad to consider your Sheet Metal Machinery needs, as well as your requirements for special machines.

If you are thinking of making your own sheet metal parts or producing sheet metal products for the trade, get in touch with us at once. We can save you money and furnish a most satisfactory and complete equipment.

Catalog and prices furnished on request

**The Yoder Company**  
Engineers Building  
CLEVELAND - - OHIO

## One of the Steels of the Century Centurion High-Speed

Made from the **BEST** Materials

*Consequently*

Will do the **BEST** Work

*Quality*

*Delivery*

*Service*

*We have a catalog waiting for you. Write for it.*

**THE CENTURY STEEL CO. OF AMERICA**

Manufacturers of High-Grade Crucible Steels

General Office and Works:  
POUGHKEEPSIE,  
N. Y.

Sales Office:  
120 BROADWAY,  
NEW YORK

Please mention The Hub when you write

# 400 Shafts and Shoulders in 10 hours on a **NORTON** Grinding Machine

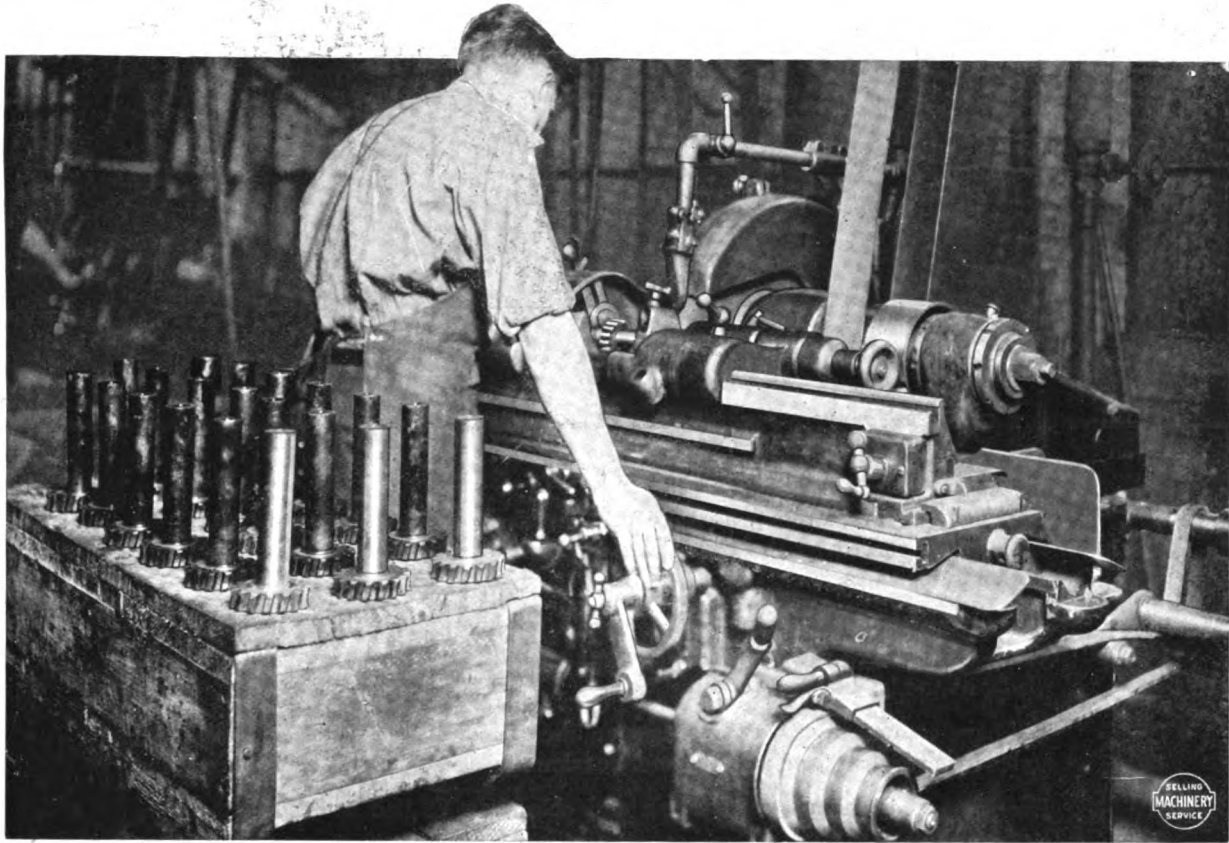

If you are doing roughing or finishing in a lathe, these figures will be interesting—and may open your eyes! This record is not a sprint, stunt or stampede—simply an every day, all day, steady jog with the Gemmer Mfg. Co., Detroit.

The subject shown is part of an automobile steering worm mechanism. Shaft is 5 1/2 in. long, 1 1/8 in. diameter. Carries a shoulder 2 in. diameter by 3/8 in. wide which must be at right angles to the shaft. The limit is very close. Production is 400 in 10 hours.

Do you know the Norton Grinding Machine in very many shops is superceding both roughing and finishing on the lathe? Doing the work in less time, with less labor and greater ease in handling? The finished result admits of no comparison.

The advantages of Norton Grinding Machines are past enumeration here. If you will just write us we'll go into the subject as far as you like.

## NORTON GRINDING COMPANY

Chicago Store, 11 N. Jefferson St. WORCESTER, MASS.

Vonnegut Machinery Co., Indianapolis, Ind.; Robinson, Cary & Sands Co., St. Paul and Duluth, Minn.; Manning, Maxwell & Moore, Inc., St. Louis, Mo.; Prentiss Tool & Supply Co., New York, N. Y.; Boston, Mass.; Buffalo, N. Y.; Rochester, N. Y.; Syracuse, N. Y.; Scranton, Pa. The Motch & Merryweather Machinery Co., Cleveland, O.; Detroit, Mich.; Pittsburgh, Pa.; Cincinnati, O. Eccles & Smith Co., San Francisco, Cal.; Los Angeles, Cal.; Portland, Ore. The Canadian Fairbanks-Morse Co., Ltd., Montreal, Que.; Toronto, Ont.; Vancouver, B. C. C. T. Patterson Co., Ltd., New Orleans, La. Kemp Machinery Co., Baltimore, Md. W. E. Shibley Machinery Co., Philadelphia, Pa. Alfred Herbert, Ltd., Coventry, Eng.; Paris, France; Milan, Italy. Schuchardt & Schutte, Vienna, Austria; Prague, Austria; Budapest, Austria; Stockholm, Sweden. Post Van der Burg & Co., Rotterdam, Holland. The F. W. Horne Co., Tokio, Japan. 545 N

Please mention "The Hub" when you write

# MERITAS

## LEATHER CLOTH

### Get Samples for Comparison

Carriage manufacturers who take pride in their products are more and more being forced by the conditions of the leather market to depend on leather substitutes.

And fortunately the development of such a product as MERITAS Leather Cloth has reached such a state of perfection that carriage buyers accept it gladly as the leading leather substitute.

We have created a most comprehensive line of MERITAS Leather Cloth, styles for every carriage and automobile trimming and upholstering purpose.

Every wanted weight, grain, finish and color can be had in MERITAS Leather Cloth.

Our five immense plants are busy producing goods for quality-wise manufacturers. Have you been overlooking this line instead of looking at it and making quality comparisons?

#### Send for Samples

State for what purpose the goods are desired, so we may send samples to meet your specific requirements.

The trade mark MERITAS Leather Cloth is stamped on the back of each factory roll.

**The Standard Oil Cloth Company**

INCORPORATED

320 Broadway

New York



Please mention "The Hub" when you write

# **ANNOUNCEMENT**

---

In addition to our regular line of metal and wood auto body and aeroplane machinery, we have opened a department for the manufacture of **AUTOMOBILE HARDWARE** and are now in a position to supply many parts

**Windshields**

**Pedestal Bases**

**Rocker Plates**

**Hinges**

**Stock Clamps** (for use in wood mill)

**Special Parts**

**Aeroplane Hardware**

**Special Tools** (for body machinery)

We would suggest that manufacturers place their orders for hardware parts soon, as our supply is to be limited. If in need of any special parts **WRITE US** and we shall be glad to give you all information possible. Automatic Machinery enables us to turn out parts rapidly and at a low figure.

**Get our prices before placing order**

**Pettingell Machine Co.**

**Amesbury, Mass.**





# EMPIRE STEEL TUBING

far excels ordinary tubing. It is especially prepared for the manufacture of *Automobiles, Auto Trucks, Aeroplanes, Motorcycles, Bicycles, Tricycles, Velocipedes, Beds, Baby Carriages, Pumps, etc.*

Made round or square, with welded, lock or open seams.

If you wish to manufacture products of the highest character insist upon *Empire Steel Tubing.*

**EMPIRE**  
**ART METAL CO**  
INCORPORATED  
**COLLEGE POINT, N.Y.**



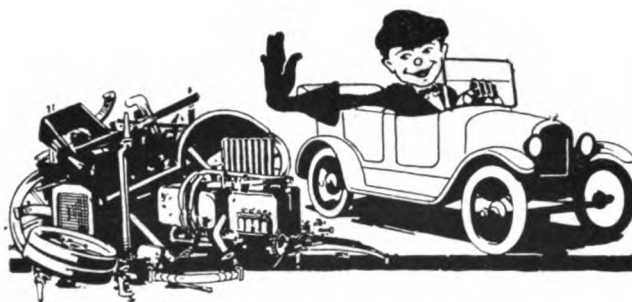

## Prevent Friction From Sending Your Car to the Scrap Heap

Friction will slowly but surely send a car to the scrap heap. In spite of lubricating oils and greases, it continually wears away the bearings. Every bearing is full of microscopic holes and pin points which will, if left alone, cause ruinous friction.

Dixon's Selected Flake Graphite is the only lubricant that will fill up these holes and build up around these pin points a smooth, oily veneer that grows finer and more smooth with use and wear. With this rare form of flake as a basis we have produced a line of graphite lubricants specially designed for every separate part of the car.

Try Dixon's Transmission and Differential Grease No. 677 and see what a difference it will make in mileage and smoothness of running.

Write for Booklet No. 123-G, "Help You Help Your Car."

**DIXON'S**  
GRAPHITE  
Automobile  
**LUBRICANTS**

Made in Jersey City, N. J., by the

**Joseph Dixon Crucible Company**

Established 1827



Please mention "The Hub" when you write

# The Measure of Superiority of

The Threading Tool, with lockable spring head, will do roughing, finishing and threading, at one setting in the tool post



## WILLIAMS' "AGRIPPA" TOOL HOLDERS

"THE HOLDERS THAT HOLD"



The Planing Tool has a serrated ring of improved steel which affords unequaled variety and rapidity of adjustment. The ring is correctly hardened to resist the wear of the cutter. The body of the holder receives a very different heat treatment that prevents breakage

is the proportion in which they excel and endure

You can verify our GUARANTEE of their exceptional resistance, adjustment, interchangeability, usefulness, life and economy by exhaustively testing them on your own machines

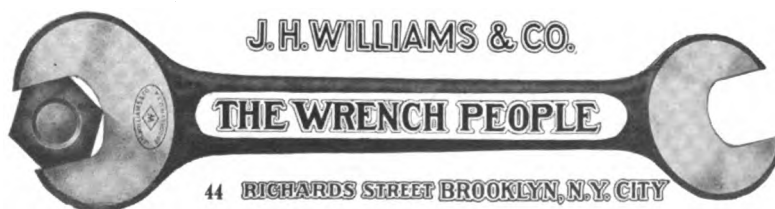

Please mention "The Hub" when you write

# The Hub

Vol. LIX

NEW YORK, NOVEMBER, 1917

No. 8

Published Monthly by

## THE TRADE NEWS PUBLISHING CO. OF N. Y.

PAUL MORSE RICHARDS, *President* G. A. TANNER, *Secretary and Treasurer*  
EDISON BUILDING, COR. ELM AND DUANE STS., NEW YORK

THE HUB, a monthly authoritative journal on all subjects pertaining to the vehicle industry from its engineering and construction viewpoints. It publishes information of live interest to manufacturers of motor vehicles, trailers, carriages, wagons, the accessory trades, repair shops and garages.

Subscription price for the United States, Mexico, Cuba, Porto Rico, Guam, the Philippines, and the Hawaiian Islands, \$2.00; Canada, \$2.50; payable strictly in advance. Single copies, 25 cents. Remittances at risk of subscriber, unless by registered letter, or by draft, check, express or post-office order, payable to the order of THE TRADE NEWS PUBLISHING CO.

For advertising rates apply to the publishers. Advertisements must be acceptable to publishers. Copy for new advertisements must be received by the 25th of the preceding month. All communications must be accompanied by the full name and address of writer.

Entered in the New York Post Office as Second-class Matter

## General Business Conditions

The consumption of coal and the traffic of the railways indicates that industry and trade are up to the limit of facilities. More coal is being mined than ever before, but not enough to supply the demand; more freight is being handled by the railways than ever before, but they cannot promptly move all that is offered. Business is harassed by many uncertainties and vexations, and war business is interfering with peace business. Government orders are taking up more of the productive capacity than was predicted of them some months ago. General trade is good, and merchants have confidence that it will keep up, because the buying power of the population is enormous. Stocks in first hands are light, and owing to high prices distributors are disposed to avoid heavy stocks.

The labor situation is acute, for there literally is no limit to the demand for men. Employers in various lines are bidding against each other for them. There is no prospect of an enlarged supply of labor, except as women are introduced into new occupations, but this is constantly going on. In the matter of industrial relations, developments on the whole are reassuring. The most serious disturbances of recent months have been either formally settled or are in process of adjustment, and in many instances settlement has included agreements which look to the amicable adjustment of any further differences that may arise during the war. The recognized labor leaders have used their influence to compose the difficulties, and to keep work going. It is not to be expected that in abnormal times like these all friction can be avoided, or that no unreasonable action will be taken, but it seems due to say that the

leaders and the rank and file have shown a patriotic spirit. There has been recognition among both employers and employes of the public interest in the uninterrupted activity of all the essential industries. As the war goes on we may hope that the spirit of patriotism will grow stronger, and that all will feel in increasing degree the importance of national unity, and of maintaining the industries at their highest efficiency. Some observers are sanguine enough to think that industrial relations will be permanently better because all classes will draw closer together during the war.

## War Stimulates Co-operation

It must be very gratifying to those who have persistently advocated co-operation between various manufacturing departments to find that the war is effectively accomplishing what they have failed to do without its aid. No greater example of harmony between the component parts of a great industrial machine is afforded than the development of the standardized motors for the aeroplane and motor trucks to be used by the government in France. In each case eminent engineers gladly contributed their genius to the perfection of an engine designed to simplify the work of manufacturers. Now that the designs have been completed the task has been shifted from the shoulders of the designing engineer to those of the production engineer and the operating officials. That these men have fully sensed their responsibility is indicated by the reports announcing the early completion of motors constructed from the drawings sent out by government engineers. All that remains to make the triumph of industrial co-operation complete is for the manufacturers to turn out the standardized motors in such quantities that the American forces in Europe will never want for trucks or planes.

## Chicago Auto Show

The Chicago automobile show will start Saturday, January 26 and continue to Saturday, February 2. The professional session of the S. A. E. will be held Friday, February 1, during the day. Following this meeting, which will be devoted largely to tractor subjects, the war dinner will take place at the Hotel La Salle. Accommodations for 1,000 persons will be provided.

## Clearing House for Show Visitors

A hotel clearing house will be established in New York to provide without delay accommodations for the multitude that will flock to the city for the Automobile Show in January.

### S. A. E. Plans Winter Activities

The indications are that the Society of Automotive Engineers will have an unusually busy winter. Among the new moves is the contemplation of winter meetings in Chicago, and presumably at show time, January 6 to February 2. A professional session will be held during one day, and in the evening there will be a "Patriotic Dinner."

Wednesday and Thursday, January 9 and 10, will be the dates of the meetings in New York and during the show week. Wednesday will be Standards Day. On Thursday there will be three gatherings which will be followed by a dinner in the evening. There will be two special meetings of the society, these to take place during the aviation and motor boat shows. At the present time the membership of the S. A. E. is 2,775. At the next meeting 200 names will be acted upon.

### Census Lists Only 71,745 Engines

In the census of 1914 there are listed 549 manufacturers of internal combustion engines, according to figures just issued by the Bureau of the Census. Due to the lack of detail required on the reports on which the census was taken, however, it is impossible to classify the manufacturers or their product under any automobile heading that can be regarded as accurate. Only 71,745 gasoline automobile engines are shown in the figures, which do not include engines made by automobile manufacturers, nor in some cases automobile engines made by firms who also turn out engines for other purposes. During 1914 there were produced approximately 573,000 automobiles, and comparison of this figure with the census report of engines for automobiles reveals the poor character of the government statistics on the subject.

### Service Overseas

Blacksmiths and wheelwrights are wanted for early service overseas. The men in the front line trench need the help and co-operation of skilled men back of the lines, and blacksmiths and wheelwrights are wanted at once for the Enlisted Ordnance Corps, National Army.

Uncle Sam is calling on our trade to come across and help his fighting men. There is a lot of work to be done over there, and the call has gone out for blacksmiths and wheelwrights between the ages of 18 and 40 who want to do their bit, and who know their job.

Modern war is a tremendous business, and the army that wins is the army which has the best equipment and the best men. The men are over there now—they are ready to go ahead, but they still need experts in our line to repair and maintain their equipment. There is a fine chance for every man who wants to help. Write to the Chief of Ordnance, War Department, Washington, D. C.

### Advance in Wagons

On October 26 one of the large wagon companies issued a bulletin to its dealer customers announcing an advance of 20 per cent on wagons, trucks, wagon boxes, shoveling boards and steel truck wheels. In connection with the announcement it is stated that wagon factories are swamped with current business, including government demands, which must have precedence. It was also stated that great difficulties are being experienced in securing both material and labor and that material prices have been substantially advanced.

### What Is New in Motor Cars

In spite of the apparent standardization of the automobile line, there is a lot that is new this year in motor cars. When you walk into the show this winter you are going to see as much variety and change as you did last year, and most of it is naturally going to be apparent in the bodies of the cars and their fittings. This is going to be a year where individuality of style is going to tell more than ever before.

It must be said, however, that all the changes of the year are not going to be in bodies. To those who dig beneath the surface there is going to be shown some of the best work in engineering that the automobile industry has ever developed. The manner in which the descending grades of gasoline are handled is highly important. The matter of lightness, developed to such a high extent last year, has been carried further. Acceleration, that quality dear to the heart of American motorists, has been advanced still further. The electrical equipment of the car is better, ignition is faster and more sure, carburetors are better, the engine itself is a cleaner and more powerful unit for its size, but let us pass all this by for this time and confine ourselves to the part that will be most obvious the moment we enter the great shows, or in fact any showroom of a representative automobile company.

#### A Closed Car Year

We are sure to be impressed by the fact that this is a great closed car year. When we look closer into the subject we are going to find also that closed car design has undergone some fundamental changes since last winter. In fact, for the first time perhaps we will be able to say that the closed cars have changed more than the open.

Roofs are flatter, the belt line of the car which encircles it at the same level as the top side of a touring car, is flatter, the doors are more nearly square and the side lines of the hood are sharper, giving a far more angular appearance than the molded forms of a year ago. At the same time on many of the designs the line across the windshield is narrower, due to the fact that there is more taper at the front end. The radiator is higher and the line at the top of the cowl takes a very slight upward rise to do away with the "broken back" appearance that characterized the first of the straight line hood-to-cowl schemes.

Within, the bodies are just as well furnished and just as luxurious, but are not so much inclined to the "gingerbread" order of trimmings. There are some useful accessories to be found in the cars, however, that were only on a very few last year. One of these is the use of the dictaphone. This same device which allows the detective to overhear the whispers of criminals is utilized to allow the passenger in the limousine to speak to his chauffeur in the front seat on the other side of the glass partition without raising his voice. He simply has to press a button and the voice in the rear compartment is picked up by the sensitized diaphragm and carried to the trumpet leading to the car of the chauffeur.

There are also some changes in the styles of closed bodies. One of the most noticeable trends, says Merle Shepard, in the New York American, is the fact that the coupe is giving way to some extent to the brougham. In the coupe the passengers sit around in a group with the driver's seat somewhat advanced, a seat about wide enough for two alongside him and another seat facing in the opposite direction diagonally across from the driver. With the

coupe the seating is apt to be a little crowded when all four seats are occupied, and, furthermore, one of the passengers must ride backward in a rather strained position. Still, it is probably the most sociable of all the seating arrangements.

#### Brougham vs. Sedan

The brougham, which is displacing the sedan to some extent, has a seating arrangement which might be called a close-coupled sedan. The front seats are divided in the usual way, and the rear seat is brought close to it, like the last year's four-passenger roadster. This method of seating gives a very chummy arrangement, and whatever any one may think of its success or failure, the proof of the popularity of the arrangement lies in the fact that a great advance in brougham sales is reported from nearly all the larger cities throughout the country.

One cannot talk about closed bodies without mentioning the sedan. The sedan is the touring car's close competitor in popular favor. It used to be that the touring car came first and the roadster next, but that day has gone by, and

There is going to be more variety in standard colors next year than has ever been the case since the early days of the industry, when the leading cars were a bright vermilion or crimson, with vertical pencil lines covering the body from top to bottom. The cars are not going to be gaudy, but they are going to be durable, effective shades of blues, greens, tans, grays, and all the staple colors. The blacks will remain to some degree, of course, but there are going to be less of them than before.

The price is going to be higher. The war tax adds about \$30 to a car that formerly cost about \$1,000. The prices of material have not gone up to any degree, so there will not be likely to be any further increase for that reason. Taking the matter all in all, whatever increase there is will not be enough to stop a man buying his car. If he is wise enough to know he needs it, he is going to get it.

The fellow who thinks that the reason why some men get along so much faster is because they are geniuses does not realize that genius is 90 per cent hard work.



**Class B War Truck, Designed and Produced by the Automobile Industry, Rated at 6,000 Pounds Load Capacity, with Standard Service Body**

the sedan has displaced the roadster from second place. There is good reason for this. The number of people who use their cars as everyday conveniences is growing rapidly. These people do not like to stop to put up side curtains whenever the weather looks bad, or when it becomes cold. They only tour perhaps a week in a car, and many do not even tour that much, so naturally the car which gives the maximum service with the least attention to tops and side curtains, makes the strongest appeal. The answer is naturally the sedan.

The sedans of this year are not much different in interior finish. They do conform on the exterior with the latest in closed body lines, particularly in the flat top and the horizontal belt line, with the turn up at the rear very little, if used at all. The sedan type of car shows to a very noticeable extent the great tendency toward angularity that would be almost box-like were it not for the relief afforded by the slants in the cowl and the taper in the body.

Last but not least come the touring car and roadster.

#### Detroit Would Regulate Tire Widths

The common council of the city of Detroit is preparing an ordinance to regulate the use of trailers. Members of the committee are working on a plan which would establish minimum tire widths for certain loads. At present written permission must be obtained from the department of public works before a load of more than 15 tons can be moved through the city streets.

#### Tractor Attachment Makers Associate

Manufacturers of tractor attachments for passenger cars have formed the National Tractor Attachment Association, in Chicago, and through it will undertake a campaign of education directed at the users of tractors and attachments. J. H. Palmer, of the Farm Tractor Co., Fond du Lac, Wis., is president of the association, and V. P. Wilkins, of the Unitractor Co., Chicago, is vice-president.

Many a man puts up a bluff to trip over it.



**TOWN LANDAULET**

Body by The M. Armstrong Co. Mounted on Stearns chassis

Rear seat carries three people. There are two drop seats which fold against division

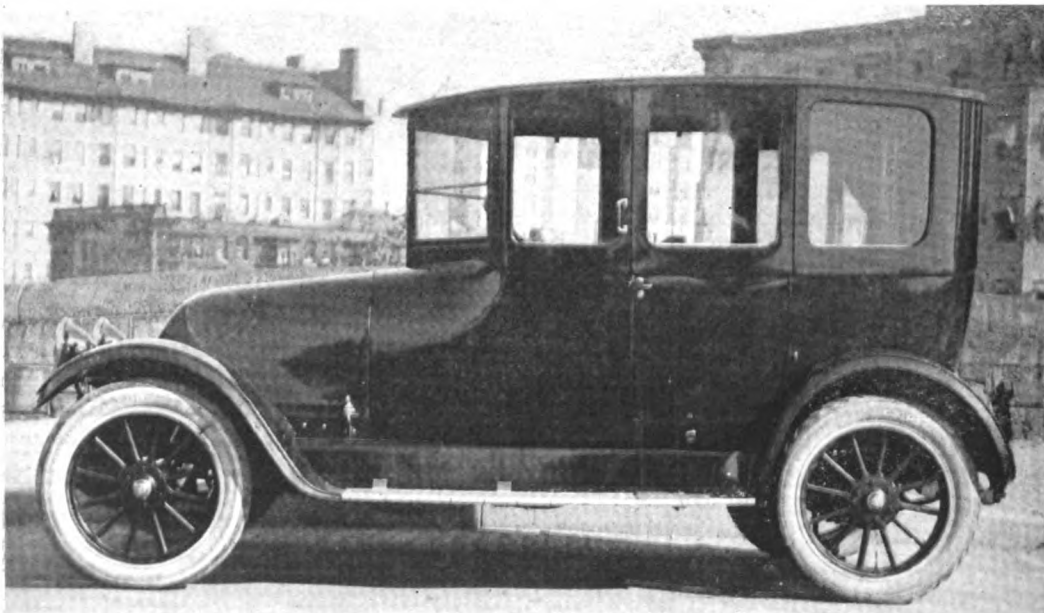
**SEDAN**

Body by Bela Body Co., Framingham, Mass. Mounted on Franklin chassis

In the last four months the Bela Body Co. manufactured 350 of these bodies for the Franklin Co., who were so well pleased that they have since placed an additional order for 750 bodies.

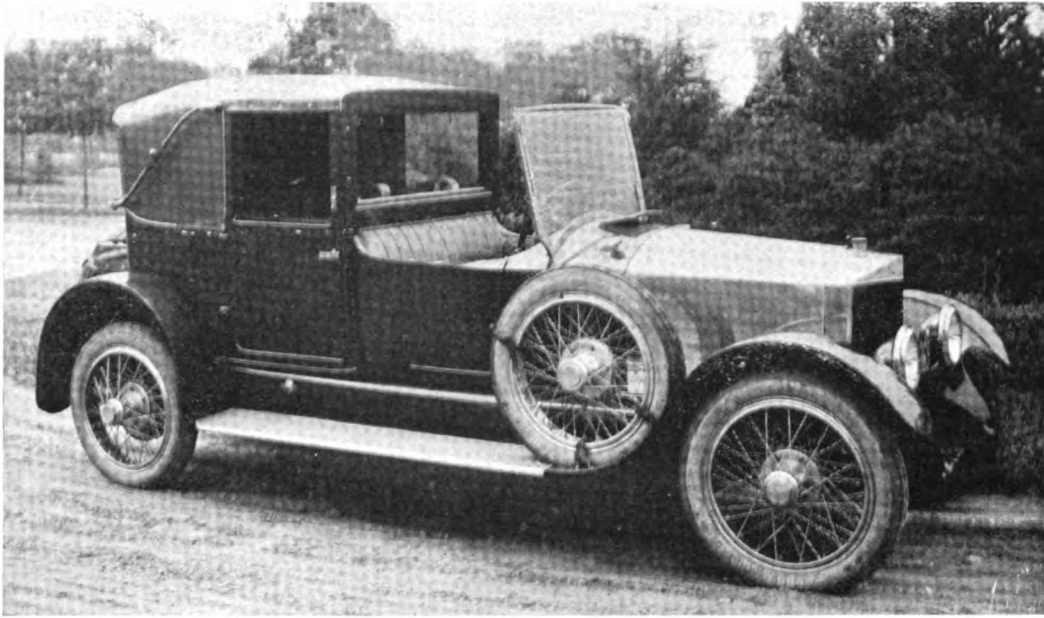

**FULLY COLLAPSIBLE TOWN CAR**

Body by Chas. S. Caffrey Co., Camden, N. J. Mounted on special chassis

Body painted Willey's French Grey No. 1187, rubbed to a satin finish. Top trimmed in long grain Laidlaw leather of a color to match the French grey. Trimmed with Laidlaw material with the old English Davenport style of trimming—square edge back, made individual—that is, back absolutely free and independent for each passenger. Cushion made on a superstructure with independent reversible cushions of down. The curtains are hemstitched; and it makes indeed a very comfortable and attractive job. The driver's seat is finished completely in long grain bright black hand buffed leather, finished around the doors and edges with lead filled, leather covered mouldings.

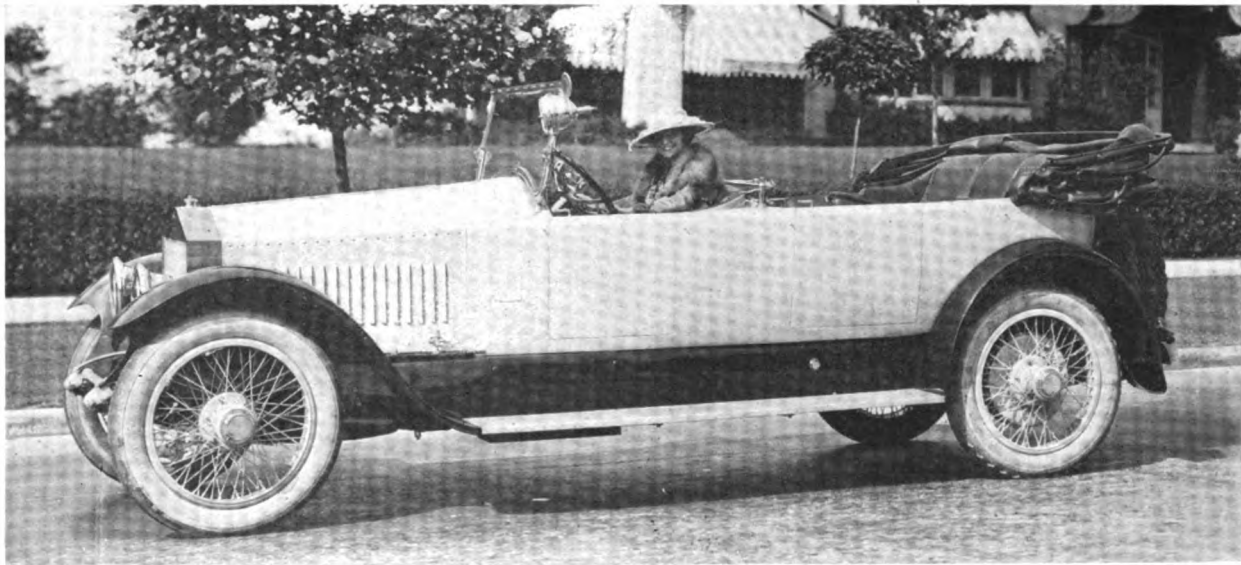

**SEVEN-PASSENGER TOURING CAR**

Body by The Rubay Co., Cleveland, O.

Mounted on Cadillac chassis, 145 in. wheelbase, with Rolls-Royce type of radiator. Note the specially long bonnet and the Rolls-Royce line carried from the full length of the body. Car is equipped with tonneau windshield and Victoria leather top.

## Electric Japanning Ovens Great Time Savers

Great strides have been made in recent years in reducing the time required for japanning operations. Work that formerly took from five to nine hours is now completed in half an hour to one hour, and even better speeds are expected, especially with the electric oven. The heating units of this oven consist in general of a framework of steel or cast iron, supporting insulators made from mineral compounds, which afford high insulation resistance even at the fusing point of the metal resistor. This resistor is usually a nickel chrome alloy, manufactured as a fat ribbon which is wound continuously around two insulators, thus forming one heating unit. It is non-corrosive in air at 1,500 deg. F., but in japanning ovens the air seldom reaches a temperature above 600 deg. F.

Practice has shown that it is best, where a number of these heaters are connected, as in ovens, to use steel bus-bars and to have all connections mounted on insulators having the same characteristics as the heat insulators. The complete heater usually runs in units of from 2½ to 10 k.w., which may be placed anywhere on the walls or floor of an oven until practically a uniform temperature is obtained throughout. This leads to high quality finish and speed, together with duplication of work, both as to quality and time. Microphotographs taken of japanned pieces, where the same grade of metal was covered by the same grade of japan in the same room, one man performing all the operations, show that the higher the proportion of heat by radiation and the less by convection the higher is the quality of the work. The second coat baked electrically is superior to a third coat of the other type.

The control of temperatures in japanning is most essential, especially where it is desired to insure uniform production of duplicate parts. Electric control is of two kinds, hand and automatic. Hand control involves the use of numerous switches, so connected with the heating elements that the desired number of heaters to produce or hold a given temperature can readily be thrown on or off. This is a cut and try method, but in several instances is giving satisfactory service. Automatic control involves the use of a capillary tube thermometer that actuates a contact maker through a relay, throwing off part or all of the heaters when the oven reaches the desired temperature, and again throwing in these heaters when the temperature falls. The bulb or sensitive member of the thermometer is usually about 15 ft. in length, and it is immersed inside the oven. The extension of this tube outside the oven is armored and is made of sufficient length to locate the instrument properly. A liquid that vaporizes at a temperature slightly above ordinary atmospheric temperature is the actuating medium. The instrument has two indicating hands, which are set at the maximum and minimum temperatures desired.

The principal heat losses of a japanning oven are losses due to radiation from the oven, losses due to ventilation and losses due to absorption of heat by the work, together with all parts within the oven. The less the radiation and ventilation losses from the oven the greater is the amount of heat available for actual work. As a result the oven walls, floor and roof should be constructed of a high-grade heat insulating material and should have little mass, in order to keep its heat absorption as low as possible. A 4 to 6 in. wall lined with diatomic earth or

similar products seems to meet the requirements. Furthermore, as little "through" metal as possible should run from the inside to the outside of the oven. The thermal conductivity of wrought iron and mild steel, as used for channel irons and bolts, is about 1,400 times that of good insulating material. A ¼ in. bolt will radiate about the same amount of heat to the outside air as 7 in. square of good insulating material.

From both a baking and a safety standpoint just enough air must be brought into the oven to reduce the vapors given off by the japan to below a point where an explosive mixture is formed, but not enough to cool the oven and retard the baking. This means that for every gallon of japan baked within an oven at one time 1,200 cu. ft. of free air should be taken into the oven during the vaporizing period. It has also been found good practice to distribute the ventilators in different parts of the oven. As the volatile gases liberated from the japan are heavier than air, it is well to place some ventilators where the heavy gases will be removed first.

With radiation, ventilation and absorption values expressed in British thermal units the installation of the proper number of electrical heaters becomes a simple matter, for the reason that the conversion of electrical energy into heat is a process having 100 per cent efficiency. That is, for every kilowatt-hour of electrical energy expended 3,412 B.t.u. are generated.—From a paper by C. D. Carlson read before the Cleveland Engineering Society.

## Steel and Iron Prices

The President has approved an agreement between the War Industries Board and the steel men, fixing the following prices, which become effective immediately, and are subject to revision January 1, 1918:

Commodity and Basis	Price Agreed Upon	Per Cent of Reduction
Iron ore, lower lake ports.....	\$5.05	.....
Coke, Connellsville .....	76.00	62.5
Pig Iron .....	\$33.00	43.1
Steel bars, Pittsburgh, Chicago.....	\$2.90	47.3
Shapes, Pittsburgh, Chicago.....	\$3.00	50.00
Plates, Pittsburgh, Chicago.....	\$3.25	70.5

\*Gross ton. †Net ton. ‡Hundredweight.

### Prices the Same to All

It was stipulated, first, that there should be no reduction in the present rate of wages; second, that the prices above named should be made to the public and to the Allies, as well as to the government, and, third, that the steel men pledge themselves to exert every effort necessary to keep up the production to the maximum of the past, so long as the war lasts.

### Effect of the Changes

Compared with current prices and those of the last three years the President's quotations show a marked decline in case of the major products. This table shows the changes, pig iron and coke being in gross tons, and the others in hundredweights. The quotations for the three years are, average prices, Pittsburgh basis:

	Present Prices	1916	1914	Fixed Prices
Pig Iron .....	\$45.00	\$24.00	\$14.00	\$33.00
Coke .....	13 00	4.78	2.32	6.00
Steel bars .....	4 25	2.48	1.15	2.90
Steel plates .....	8.00	2.82	1.14	3.25
Shapes .....	4.50	2.50	1.16	3.00

The marking down of prices for pig iron and coke, according to steel makers, will be a distinct advantage to small steel manufacturers who have had heavy costs to meet for iron and fuel.

# How Factory Lay-Outs Aid Production

## Problem of Transporting Materials and Products Through Plant to Reduce Production Costs

[Concluded from October issue]

By Edward K. Hammond\*

### Adapting Transportation Methods to Requirements of Shop

In working out methods of progressive assembly for use in his factory a manufacturer must bear in mind the volume of work which is to be handled. It would not pay to install a complex equipment of conveyors, trolley systems, etc., to facilitate handling work unless the volume of

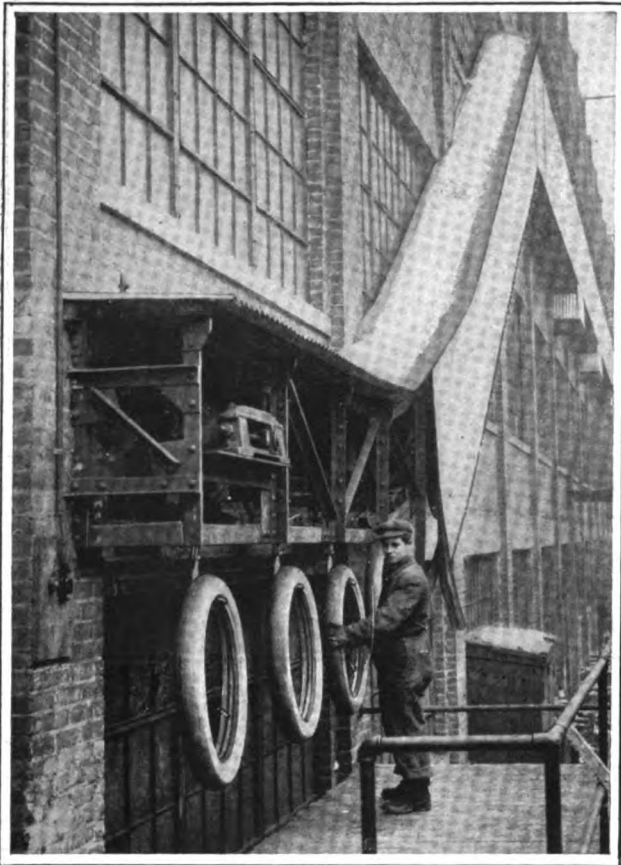

Fig. 30—Where there is considerable congestion in a shop, it may be desirable to hang conveyor systems and similar equipment on the outside of buildings. A case in point is seen in the accompanying illustration, which shows a view of a conveyor system installed in the Studebaker Corporation factory for handling tires, wheels and hubs. The conveyor is an endless chain with hooks for carrying the work.

product was sufficient to keep equipment of this kind employed so that a reasonable return would be earned on the investment. Even in highly organized shops handling a moderate volume of product each day, little attempt is made to employ a complete outfit of mechanical contriv-

\* Associate editor of Machinery.

This article and illustrations reproduced through the courtesy of Machinery.

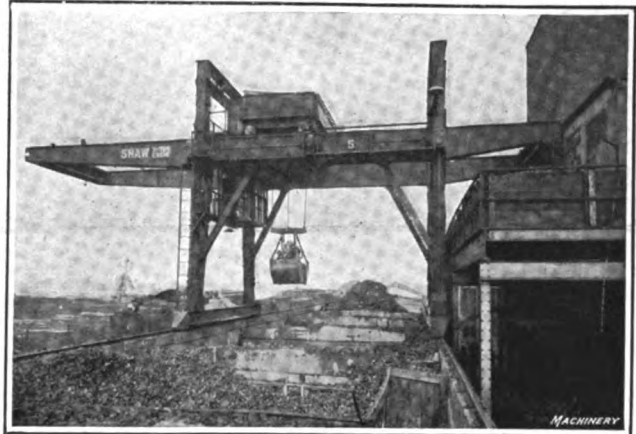

Fig. 31—This illustration shows a bin at the side of the railroad at the Ford Motor Co.'s plant in Detroit for storing coal, coke, limestone, scrap metal, etc. The Shaw Electric Crane Co., Muskegon, Mich., installed a gantry crane equipped with a grab bucket for handling this material

ances for handling the work, because it is realized that there would be little likelihood of obtaining a satisfactory return on the investment. Recently we have seen some exceptions to this rule that are probably due to the condition of the labor market. Unskilled labor has been so scarce and has commanded such exceptionally high prices that some manufacturers have substituted mechanical means of handling as far as possible. This has been particularly true in shops engaged in certain munitions work where the necessity for making deliveries at an early date has demanded the employment of every possible means to increase production rates.

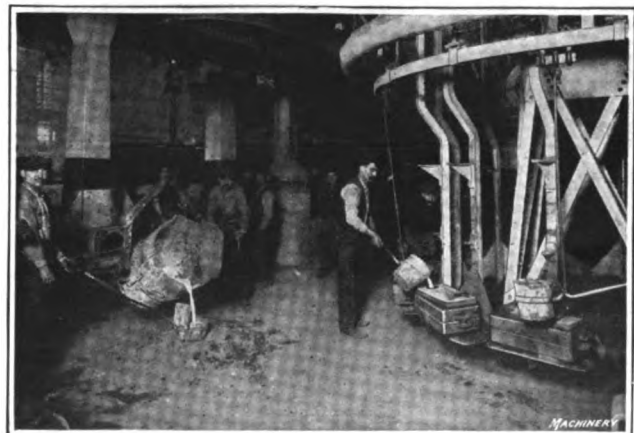

Fig. 32—To facilitate pouring metal into molds in the Ford Motor Co.'s foundry, molds are brought in on a conveyor and transferred to a carousel on which each mold is supported by a pendulum. This swinging support eliminates vibration and prevents molds breaking. Molds are carried away by a second conveyor

Plants handling an extremely large volume of product are best suited for the installation of complete systems of conveyors, trolleys, gravity carriers, chutes and other forms of equipment arranged in combination, so that as soon as one workman or group of men have completed their task on a given piece of work it may be placed on a mechanical carrier that will convey it to the department where the next operation is to be performed. Aside from

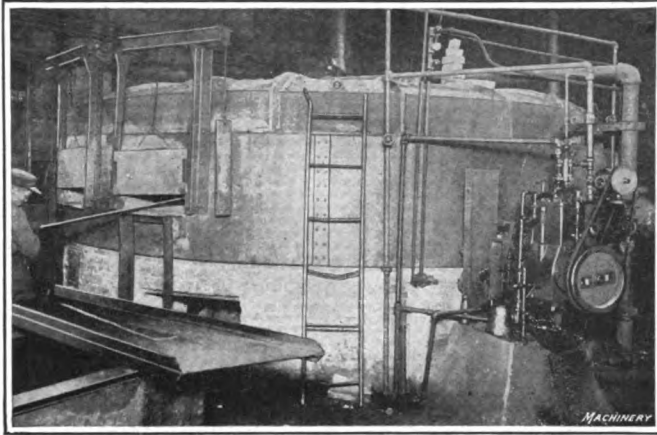

Fig. 33—In the Timken-Detroit Axle Co.'s plant special furnaces with a rotary hearth are maintained at such a temperature that forgings are raised to the proper temperature for heat treatment by one revolution. These furnaces save space and keep operator busy

the reduced cost of production made possible through the reduction in help, the employment of mechanical carriers has another important feature which commends it to the attention of manufacturers operating large factories in which there is likely to be a congestion of machines and product. Unless mechanical carriers are used the alternative is to make transfers on trucks pushed by hand or by power, and the handling of a large amount of work in this way is bound to create confusion—especially when aisles



Fig. 35—An elevator raises the work to the upper floor in the Willys-Overland Co.'s plant. This equipment, installed by the Link-Belt Co., Chicago, Ill., consists of an apron-type conveyor with cleats to prevent the work from slipping back. A chute at the left returns the tote boxes to the lower floor

are blocked or there is other interference with the movement of the trucks.

In an article of this kind it is the aim to explain fundamental principles and describe methods which the average manufacturer can employ in his own shop. On this account, the methods of handling material and product in extremely large plants are not entered into in detail, inasmuch as they require complete installations of mechanical transporting facilities and an engineering staff capable of

laying out all kinds of equipment. Nevertheless, all manufacturers will be interested in reading of the equipment employed in the factory of the Willys-Overland Co., Toledo, O., for the final work of assembling parts of automobiles.

#### General Arrangement of Equipment

The department in which the final assembly is conducted is laid out with four tracks, down which the automobiles are pulled by chain conveyors that were installed by the Link-Belt Co., Chicago, Ill. The automobile frame is placed on this track and a hook on the chain conveyor takes a hold of the front axle to draw the frame along. Features of the progressive method of assembly have been explained previously, so they need not be considered here. The point of greatest interest is the arrangement of the auxiliary carrying systems that bring parts to the main

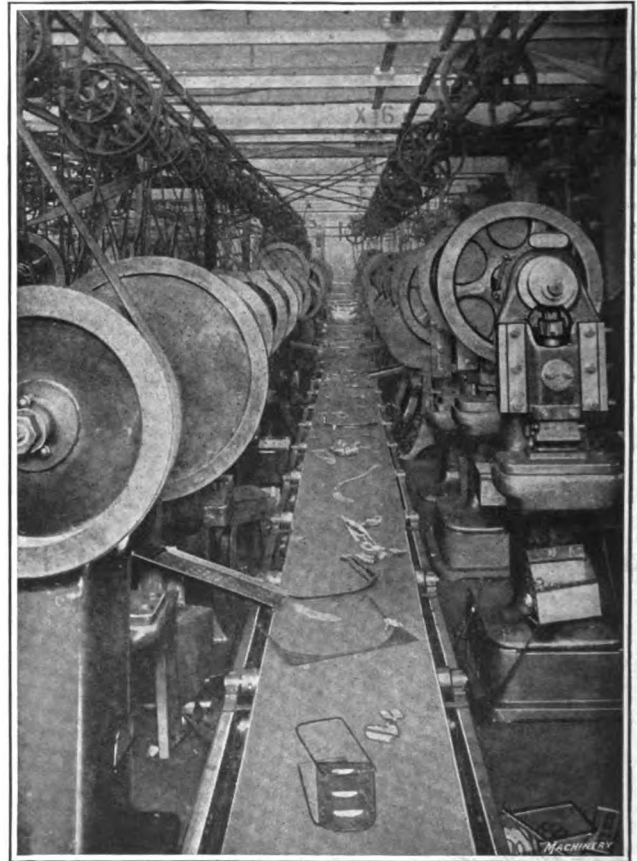

Fig. 34—In the Ford Motor Co.'s plant, use is made of belt conveyors for carrying away the product of power presses. Chutes are provided by means of which the product is transferred from the machines to the belt conveyor which carries it away. This is the means of saving the time ordinarily required for removing the product in trucks

assembling track at the different points where the parts are to be assembled onto the car. There are four of these tracks that run lengthwise down the shop, and a large number of conveyors running crosswise. Each of these cross conveyors brings such parts as lamps, mud guards, radiators, etc., to the four main assembling tracks at those points where the different parts are to be added to the car; and all the time that this continual stream of parts is running across the shop, the automobiles in course of assembly are running lengthwise, so that as each car passes down one of the assembling tracks the different parts which go to make a complete car are brought over to the assembling track and secured in place. This system has been carried to such a degree that when the gasoline



tank is delivered to the assembling track by one of the cross conveyors, it contains sufficient gasoline to allow the completed automobile to run out of the assembling department on its own power.

In the various manufacturing departments, as well as in the assembling department, use is made of conveyor systems for handling work in course of manufacture and finished parts. For the handling of a product as complex

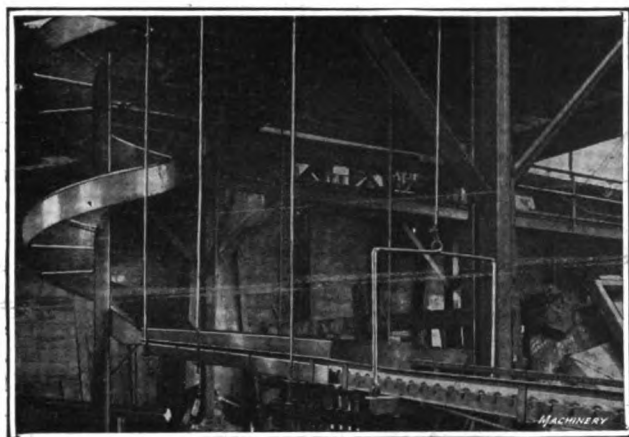

Fig. 36—For unloading flywheel castings from freight cars, the Cadillac Motor Car Co., of Detroit, Mich., has a spiral steel chute leading down from the platform on which the load is discharged. The castings are ejected from the chute onto a gravity carrier

as a modern automobile, it will be evident that a great variety of carrier systems must be provided, and in the Willys-Overland plant use is made of practically all the standard tractors, conveyors, etc. For instance completely assembled motors are handled on apron-type conveyors or trolley systems, from which they are suspended in a suitable sling. Advantage is taken of the circular form of wheels and tires, and they are rolled down gravity carriers. Gravity is also used in carrying certain forms of castings and similar parts, but it is necessary to provide some form of roller conveyor, because the castings could

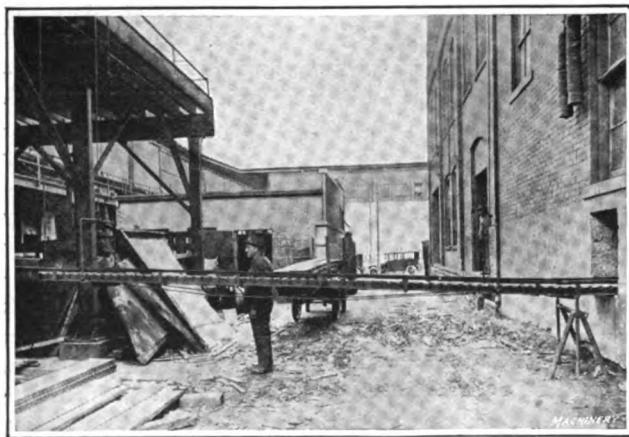

Fig. 37—This illustration shows the gravity carrier leading from the spiral chute shown in Fig. 36 to the machining shop. The carrier is suspended on cables so that it may be raised to provide the necessary head room for a team to go underneath

not be rolled. In the case of lamps, mud guards and many other parts of a like nature, there is no better method of carrying than on a trolley system, and extensive use is made of this equipment. In addition to standard conveyors, many special forms of equipment have been provided for handling parts of universal form, and a general idea of the diversity of the carriers that have been installed by the Willys-Overland Co. will be gathered from the

illustrations presented in this and the preceding installment, showing views in this company's plant. These are by no means complete, but they serve to give an idea of the great variety of methods of handling that have been adopted to meet different conditions and the care that has been taken by the company's engineering department in studying all the available methods and adopting those that have the greatest number of features to commend them.

#### Development of Special Forms of Carriers

In working out the transportation system for any factory, the engineer in charge of the work has at his disposal numerous forms of standard equipment that are manufactured by plants making a specialty of this work and it is desirable, whenever possible, to adopt the use of standard forms of equipment, because a plant specializing in such work can usually furnish equipment at a price considerably lower than that at which special equipment could be made for a given service. There are many cases however, where the nature of the work to be handled is such that it demands the use of special equipment, and under those circumstances the engineer who is laying out the transportation system would be called upon to design suitable equipment for the work. This may involve the

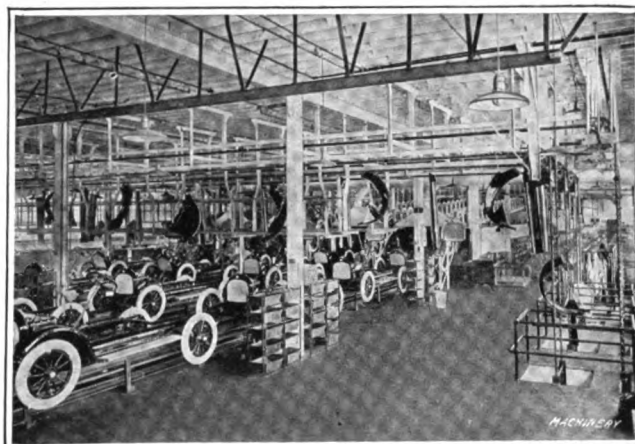

Fig. 38—In handling the progressive assembly of automobiles, the Willys-Overland Co. has tracks down which the cars are run during the process of assembly. Overhead trolley systems running at right angles to the line of travel of assembling tracks carry various parts to the assemblers

development of special methods of handling, but in many cases, however, where the nature of the work to be handled is such that it demands the use of special equipment, and under those circumstances the engineer who is laying out the transportation system would be called upon to design special equipment for the work. This may involve the development of special methods of handling, but in many cases it will be found possible to use standard equipment and add special features to adapt it for a given service.

Where it is found that standard equipment cannot be obtained for handling the work the next step of the engineer should be to ascertain whether certain standard forms of equipment furnished with special attachments for holding work, etc., cannot be made to meet his requirements. If so, it will be more desirable to use such equipment than to attempt to produce a complete special outfit.

**Truck, Tractor and Mfg. Co.**, St. Louis, has been incorporated with a capital stock of \$25,000, by Isidor M. Jacobs, Kansas City, Mo.; Norris B. Gregg, Jr., and others of St. Louis, to manufacture motors, trucks, tractors, etc.



Exports of Automobiles From United States

The following table shows the number and value of both commercial and passenger automobiles shipped from the United States to each country during the fiscal year ended June 30, 1917:

Countries	Commercial automobiles		Passenger automobiles	
	No.	Values	No.	Values
<b>Europe—</b>				
Azores and Madeira.....			1	\$700
Denmark.....	58	\$81,414	1,215	932,768
France.....	4,264	13,854,903	1,367	836,557
Gibraltar.....			9	11,518
Greece.....	3	2,000	78	79,913
Iceland.....			11	5,134
Italy.....	65	159,775	186	126,432
Netherlands.....	36	55,305	485	612,495
Norway.....	162	266,741	922	944,002
Portugal.....	21	45,087	283	271,421
Russia, European.....	1,783	5,428,979	780	943,003
Spain.....	29	55,808	1,125	1,195,887
Sweden.....	6	10,879	390	360,554
Switzerland.....			9	9,248
<b>United Kingdom:</b>				
England.....	6,525	17,061,105	1,268	1,444,346
Scotland.....			4	2,991
<b>North America—</b>				
British Honduras.....			12	5,774
Canada.....	636	945,047	14,421	11,143,740
Costa Rica.....	1	900	37	23,125
Guatemala.....	4	4,323	35	36,174
Honduras.....	4	4,094	42	24,564
Nicaragua.....			5	2,120
Panama.....	75	97,970	356	216,711
Salvador.....	1	868	75	62,314
Mexico.....	218	198,151	2,807	1,642,011
Newfoundland.....	1	2,675	48	38,910
<b>West Indies:</b>				
British.....	10	16,013	784	457,632
Cuba.....	397	722,519	3,529	2,545,071
Danish.....			18	9,114
Dutch.....	2	2,095	32	19,191
French.....	7	13,305	293	154,990
Haiti.....	2	1,324	29	13,780
Dominican Republic.....	22	23,640	191	96,173
<b>South America—</b>				
Argentina.....	141	146,255	3,924	2,336,001
Bolivia.....	20	48,590	141	100,151
Brazil.....	14	8,300	873	523,383
Chile.....	69	160,696	2,587	1,821,842
Colombia.....	2	4,998	173	118,937
Ecuador.....	1	2,050	137	106,478
<b>Gulanas:</b>				
British.....	1	1,529	146	65,989
Dutch.....			23	11,797
French.....			1	498
Paraguay.....			40	20,192
Peru.....	25	48,776	400	295,558
Uruguay.....	4	10,437	1,165	612,838
Venezuela.....	14	28,502	542	327,507
<b>Asia—</b>				
Aden.....			10	7,968
China.....	9	14,287	509	383,371
French China.....			20	9,325
Japanese China.....			33	17,796
Chosen (Korea).....			5	3,832
British India.....	126	205,023	3,603	2,644,085
Straits Settlements.....	57	61,881	855	585,820
Other British East Indies.....	26	38,970	110	80,033
Dutch East Indies.....	108	137,609	3,206	2,642,330
French East Indies.....			18	17,967
Hongkong.....			38	35,255
Japan.....	70	59,198	652	481,748
Russia, Asiatic.....	515	1,662,144	1,072	1,324,060
Siam.....	8	6,700	31	15,915
Turkey, Asiatic.....	2	1,143		
<b>Oceania—</b>				
Australia.....	194	237,159	5,055	3,792,571
New Zealand.....	75	119,833	3,554	2,558,118
Other British Oceania.....	1	1,688	19	11,062
French Oceania.....	2	2,750	22	12,330
German Oceania.....	3	2,377	12	5,847
Philippine Islands.....	53	57,457	1,019	686,731
<b>Africa—</b>				
British West Africa.....	115	124,574	240	144,838
British South Africa.....	34	82,957	3,423	2,378,380
British East Africa.....			94	55,681
Canary Islands.....	1	575	31	24,525
French Africa.....			41	13,315
Italian Africa.....			3	1,200
Liberia.....			1	975
Madagascar.....			1	808
Morocco.....			87	39,670
Portuguese Africa.....	1	2,500	7	5,429
Egypt.....	4	9,624	38	22,113
<b>Total foreign countries...</b>	<b>15,977</b>	<b>42,343,502</b>	<b>64,808</b>	<b>48,612,632</b>
<b>Grand Divisions—</b>				
Europe.....	12,902	37,021,996	8,133	7,776,969
North America.....	1,380	2,032,924	22,714	16,491,394
South America.....	291	460,133	10,152	6,341,171
Asia.....	921	2,186,955	10,162	8,249,505
Oceania.....	328	421,264	9,681	7,066,659
Africa.....	155	220,230	3,966	2,686,934

In addition, there were shipped to Alaska 152 automobiles, valued at \$141,128; Hawaii, 1,891, value \$1,802,413; and Porto Rico 1,289, value \$1,181,353.

Chart for Power Transmitted by Leather Belts

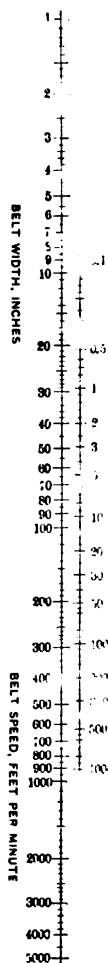

The accompanying chart may be used to determine the width of a single leather belt necessary to transmit any ordinary amount of power, the horsepower that will be transmitted by a single belt running at a given speed, or the speed at which a belt must run in order to transmit a given power. For example, to determine the power that will be transmitted by a single belt 7 in. wide running at a speed of 5,000 ft. per minute, locate the points 7 and 5,000 in the lower graduated line and then find the point midway between them. This point will be found at 44 h.p. on the upper graduated line. The dividing may be done with a rule, or a pair of dividers, or by folding a piece of paper.

Should it be necessary to transmit 44 h.p. by means of a belt traveling at a speed of 5,000 ft. per minute, the width of single belt required may be found by measuring the distance between 44 h.p. and 5,000 and then measuring an equal distance to the left of the 44 h.p. point. In this case it will be found that a 7 in. belt is sufficient. In a similar way the belt speed can be determined where the belt width and horsepower are known. This chart is based on the well known rule of thumb: A single leather belt, 1 in. wide, running at a speed of 800 ft. per minute will transmit one horsepower. —Machinery.

Join the Civic Ranks as a Technical Guildsman

In connection with or in response to the call of the President for volunteers, the attention of all technical men, i. e., men skilled in any line of science or mechanical or electrical or chemical or ordnance or explosives or mining or ship building or railroad or motors or metallurgy or building of aeroplanes or water supply or sanitation, etc., is especially invited to the need of the army for such (young) men—aged 18 to 40—in sundry branches of technical troops concerning which write for literature to Major J. E. Bloom, U. S. A., 266 Market street, Newark, N. J.

Any technical "men who are exempt" or who from any cause cannot "volunteer," can yet efficiently co-operate by forming technical patriotic educational guilds in their several industries or home neighborhoods, especially to look after the welfare of their men in the service, and to give them the opportunity of obtaining technical assistance, opinions and advice from home, in any war industry, from time to time.

New California Trailer Fees

After January 1 the California motor vehicle law will have several changes. A charge of \$2 is to be made for number plates for trailers. Where more than one is used only the rear one need carry a license plate. Trucks over 9,000 pounds with load are limited to a speed of 25 miles per hour and to 15 miles when the load is 1,200 pounds. When the load is over 24,000 pounds the speed is limited to 10 miles. Trucks using metal tires must not exceed a speed of six miles per hour.

### The Effect of Vanadium on Steels

In a paper read before the American Society for Testing Materials, G. L. Norris, metallurgist of the American Vanadium Co., of Pittsburgh, combated the theory that vanadium in steel acts chiefly or exclusively as a scavenger. It is true that vanadium oxidizes readily and will combine with nitrogen, yet, according to Mr. Norris, its value as a scavenger is nil. The effects of vanadium on steels are due entirely to its presence in the steel as an alloying element, and its influence on the other constituents with which it is in combination. When added to steel it is found in both the main constituents, ferrite and pearlite, but principally in the latter. Only a few hundredths of one per cent of the vanadium combines with the ferrite. This minute amount, however, appears to increase the strength, toughness, hardness and resistance to abrasion of the ferrite. Nearly all the vanadium, however, is found in the pearlite, in chemical combination with the cementite, as a compound carbide of vanadium and iron in the case of ternary steel, and as more complex carbides in the case of quaternary steels.

Vanadium replaces the iron in the cementite or the carbide by increasing amounts until finally, when the percentage of vanadium is about 5 per cent, all the iron has been replaced by the vanadium. The vanadium-containing cementite is not as mobile as ordinary cementite and consequently does not segregate into as large masses, but occurs in relatively minute particles and, therefore, is more uniformly distributed. It does not, consequently, readily occur as lamellar or thin plates in the pearlite, but in a granular or sorbitic condition. This strong tendency of vanadium to form sorbitic and even troostitic pearlite, is doubtless one of the reasons for the mechanical superiority of steels containing vanadium, not only statically, but dynamically.

### Tipping Dust Wagon

This vehicle is designed to meet the requirements of district and borough councils, and the like bodies, for the collection of household refuse, and the conveying of it to the local destructor.

The top is entirely covered, each side being divided into three sections of lids, all hinging on a central barrel running the full length of the receptacle. Any section can

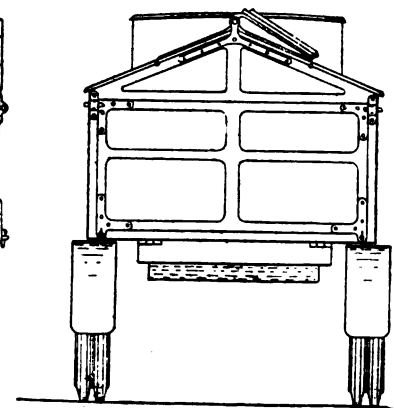
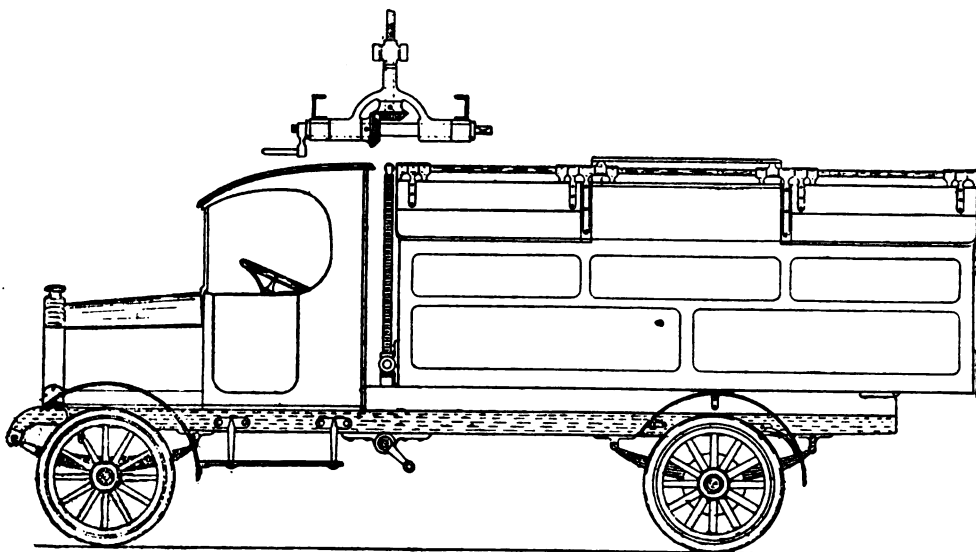

be opened independently, or the whole of one side of the top can be opened altogether.

The body is hinged at the rear of the body runners, and the tipping arrangement is operated by a crank on either one or both sides of the vehicle. The crank turns a shaft supported by a bracket on each of the side members of the frame, the said shaft carrying a driving bevel wheel, which gears in with the bevel on the swaying screw. The swaying screw is carried by a bridged bracket, which takes a bearing at each end on the driving shaft.

A bracket is fixed to the body, which carries in trunnion form a traveling nut which engages with the swaying screw. When the driving shaft is turned, this through the bevel gears operates the swaying screw, which carries upward or downward the traveling nut, thus tipping the body. Of course, if the transmission of the chassis is set too high up to allow of the tipping shaft passing over it when the latter is fixed below the chassis the tipping arrangement will have to be fixed on top of the chassis.—Automobile and Carriage Builders' Journal.

### Unique Method of Filling Radiators

The Liberty Motor Co., of Detroit, has a very unique method of filling the radiators of the cars as they leave the assembly line and are run for testing. It is desired to avoid splashing the car with water and to prevent escape of any to the floor. Since all the radiators are exactly the same size it is only necessary to have a measured supply of water for each. This is provided by a tank mounted on the wall of a capacity just equal to that of the radiator and provided with an automatic filling cock controlled by the conventional ball valve. The tester has merely to insert the hose in the radiator and trip the discharge valve. The tank thereupon empties completely and fills up again while the next car is being brought into place.

### New Overland Car Ready Next Summer

The new light model of the Willys-Overland car, designed to be produced in quantities, because of the difficulties in getting material and machinery, will not be in the hands of the public until the summer of 1918. There will be no interference or competition with the present models, as it will meet an entirely different demand.

## A Novel Method of Making Long Castings<sup>1</sup>

A novel method of making long castings has been devised by Bert L. Weaver, Harrisburg, Pa., which consists in making a sectional mold and then joining the several sections to form a large complete mold. The illustrations show the manner in which the mold for a locomotive frame is constructed by the new method. These frames are cast in steel, but the method of molding is applicable to brass and bronze castings of great length equally as well as to steel. The illustrations show the mold divided into three sections, but any number of sections can be used. The idea is to enable these very long castings to be made on a molding machine by the use of less highly skilled labor than is ordinarily demanded on this class of work.

In making a mold for a locomotive frame the first section of the pattern is placed on the mold board of the molding machine, and the first section of the drag, the

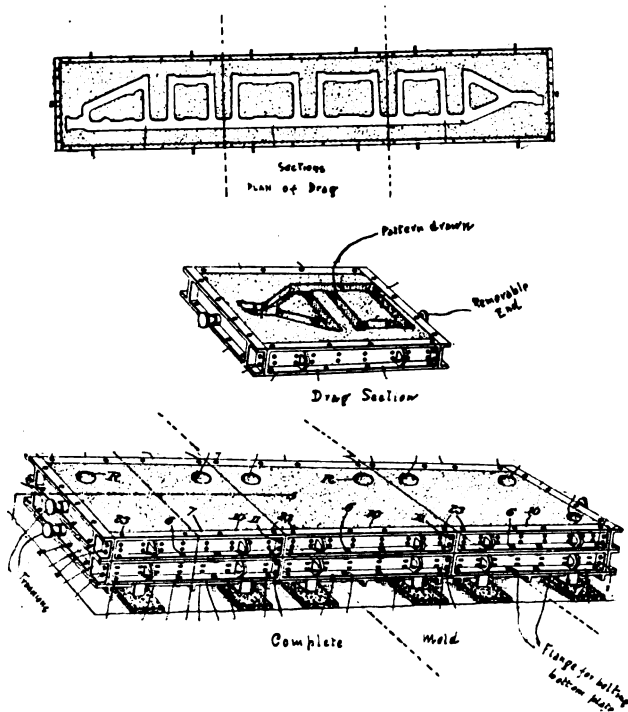

open end of which has been fitted with a temporary end, is placed over the pattern and is rammed up in the ordinary manner by the use of the molding machine, and a bottom board is clamped on and the mold is rolled and the pattern removed; the mold is finished and is placed on the floor and the removable end is unbolted and is taken away. The second section has two open ends and requires two temporary ends, but otherwise it is made the same as the first section. This section when finished is placed in line with the first section, and the loose ends having been removed it is bolted to the first section. The last section is treated exactly the same as the other two sections, and when joined together the three sections make a complete drag from which the pattern has been removed.

The cope is made in the same manner as the drag as far as the sections are concerned and the manner in which they are joined to form a complete cope. The cope is a "flat back" for this particular casting, therefore no patterns are molded therein, which greatly simplifies the work. To prevent "drop outs" in the case of the cope sections they have to be suitably barred. The sections of the cope

are made and are bolted together to form the complete cope before it is closed down upon the drag.

It is necessary, of course, to make such provision that each section of the pattern will occupy the same relative position on the mold board before they are rammed up, in order to have the several sections "register" when they are joined together, otherwise the various sections of the casting would be offset. There is nothing difficult about this part of the work, however, and no more trouble would be anticipated in doing this than is usually encountered in making the halves of a pattern register on the opposite sides of a pattern plate.

The several sections of the flask require to be both interchangeable and reversible, so it makes no difference in which manner the section is set upon the mold board.

Some difficulty might be anticipated from "runouts" at the points of juncture of the several sections of the drag, and the adjoining parts of the sand at these points would require careful attention and supervision from a skilled molder, as with unskilled help it is very evident that the removal of the "loose" ends of the sections would be likely to be attended with some tearing away of the sand at this point.—Brass World.

## Electrics Extensively Used in Postal Service

Electric trucks are being used very successfully by the Postal department in a large number of cities. St. Louis has had a fleet of electric trucks in its postal service for more than six years which have given splendid service even under the most severe weather conditions. These trucks are in service from 5:45 a. m. to 11:30 p. m. and average 30 miles each day.

The postal service in Boston uses 15 electric trucks which are operated on the "battery-service" plan. These electrics make runs of 25 miles each day, and have made substantial savings as well as greater efficiency in handling the mail.

The largest electric postal fleet in this country is probably that of the New York postal transfer service which operates 47 electrics. These trucks have been in service for three years, and are on duty for two ten-hour periods each day.

Several foreign countries have long appreciated the electric vehicle for postal service. A fleet of 30 electric trucks was installed in Vienna in 1913, and after one year's experimentation were pronounced to be particularly satisfactory for the transportation of the mails. This fleet has since been increased to 45 electrics, and one truck has a record of 15 months' postal service in Austria covering 500,000 kilometers with no interruptions for battery troubles or other repairs.

Recent reports from the Transvaal indicate that electric vehicles are used by the postal department of Johannesburg, and their economies in fuel and tire costs have done much to popularize the electric in this African city.

Electric vehicles are also being used in considerable numbers for postal service in England, and have been successfully used in Berlin, Munich and Leipzig.

An alloy for soldering cast iron, melted steel, aluminum, etc., recently patented, consists of 25 parts each of lead and tin, and 50 parts of zinc. After the articles to be soldered are cleaned, they are covered with stearic acid, or similar flux, and the alloy is applied with an extra hot soldering copper.

<sup>1</sup> Patent No. 1,233,151, July 10, 1917.

## Electric Oven Used for Baking Cores

Installation in Plant of Willys-Overland Co.—Cores Baked While Passing Through Oven on Continuous Conveyor

Electricity for heating a core oven is being successfully used in the first oven of this type that was recently installed in the aluminum and brass foundry of the Willys-Overland Co., Toledo, O. One electrically heated oven has been in use several months, and the erection of a second oven of a similar type, for larger cores, was started recently, but it is not completed at this writing. The two ovens are located side by side under the roof of one of the core rooms in which ovens of the standard type are used. One of the electric ovens is 20 ft. above this core-room floor and the other is 5 ft. higher.

The ovens are of the continuous-conveyor type, and each has a vertical leg of the same section, 20 ft. long, at the front of the oven, extending to the floor, in which doors are provided for loading and unloading the cores. The oven in use is 45 ft. long, and the new one is 60 ft. long. They are 10 ft. 8 in. in height and 5 ft. 6 in. wide, being built in two sections, with a 2 in. asbestos partition between the upper and lower sections. The framework is of steel, and the first oven has asbestos walls 2 in. in thickness on the four sides. The second oven is covered on the four sides with Nanpareil insulating brick. The ovens are supported by steel trusses on which is laid a floor or platform of steel plates. Other steel trusses carry the conveyor machinery in the ovens, so that the supports of the ovens and their conveyors are entirely independent.

Cores baked in the continuous electric ovens are made on a second-floor core room, at one end of which, at a convenient height above the floor for loading, are the oven doors. Beneath the core room is a sand storage room, from which core sand is carried up in a bucket elevator. A roller chain conveyor, 100 ft. long and 24 in. wide, extends the length of the second-story core room through the center, terminating near the entrance to the oven. This is shown in the illustration. The core-room makers' benches are located on both sides of the conveyor, and when they finish their cores they put them on plates or trays which are placed on the conveyor and thence are carried to the oven. The trays are flat sections of cast iron, 14 in. wide and 30 in. long, and having numerous circular perforations to allow the free circulation of the hot oven atmosphere. Usually, two or three cores are placed on one tray, the number depending on the size. The cores remain on the trays until removal from the oven.

The movement of the core-room conveyor, which is not in continuous operation, is controlled by a push button by an operator who stands at the end of the conveyor. This operator lifts the tray of cores from the conveyor and places it on a short section of a roller platform built on a slight incline, over which he pushes it into the oven conveyor, the tray fitting into an angle-iron shelf in a carriage or rack in this conveyor. The carriages, which are pivoted to the conveyor on 5 ft. 6 in. centers, have double rows of shelves, each carriage having eight shelves on each side. The conveyor is 126 ft. 6 in. long and has 23 carriages. The second conveyor, for large cores, has

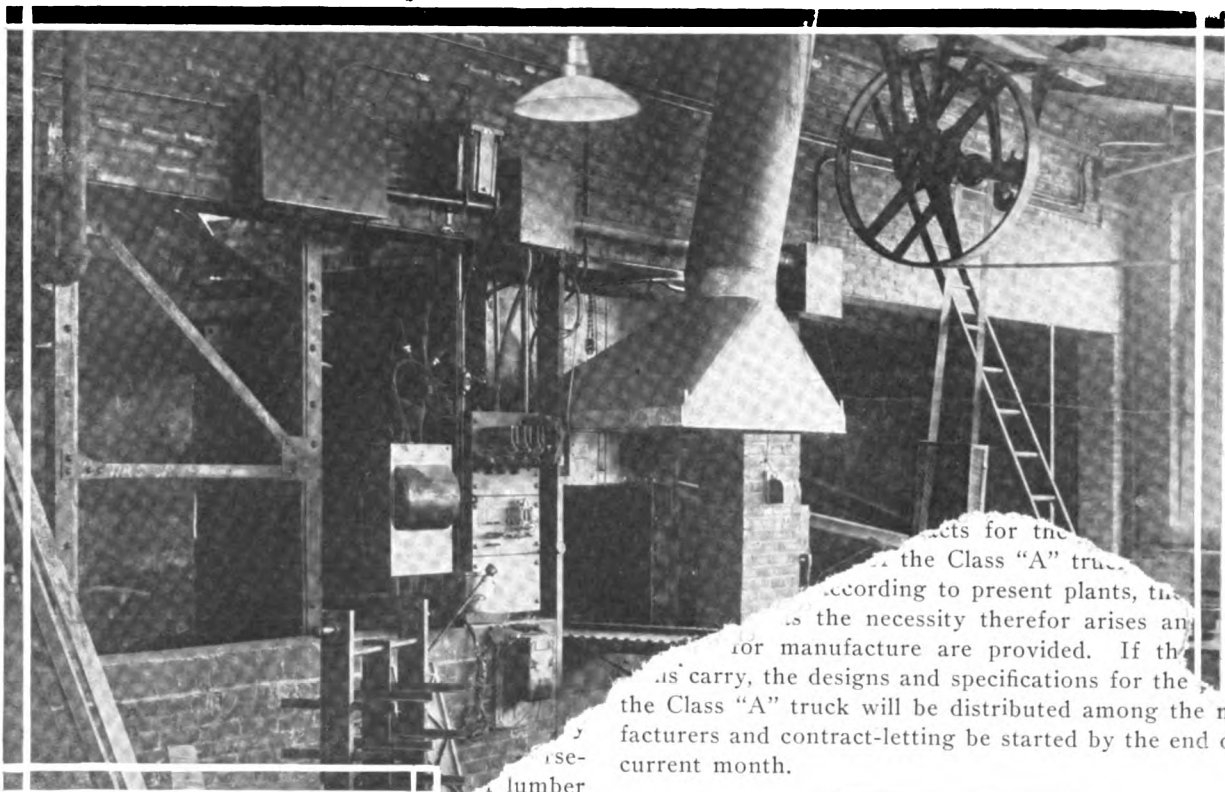

Cores placed on cast iron plates are carried into the oven on a roller platform and the plates are pushed on a shelf in the conveyor carriage. The quantity used is not these carriages is shown on the floor at the left. A considerably less than this through the upper half and back through the lower half. 50,000,000 board feet annually are carried by the a vertical section to be a very conservative figure for lower floor

acts for the  
the Class "A" truck  
According to present plants, the  
as the necessity therefor arises and  
for manufacture are provided. If the  
as carry, the designs and specifications for the  
the Class "A" truck will be distributed among the ma-  
facturers and contract-letting be started by the end of the  
current month.

## Sulky Builders Merge

The Faber Sulky Co., Rochester, N. Y., has been absorbed by the Houghton Sulky Co., Marion, O., and will be moved to the latter place. The consideration is said to be \$200,000.

## Rocking Fifth Wheel for Trailer

The illustrations, taken from *Automobile Dealer and Repairer*, show how easily a rocking fifth wheel can be made from an ordinary fifth wheel of a wagon, so that a wagon can be used as a trailer attached to an automobile. Fig. 1 shows a side view of the device and how it is attached to the bottom of the wagon and chassis frame. The upper circular part of the fifth wheel, A, is bolted to three cross bars, B, which are as long as the wagon body is wide. The bolts, C, extend up through the bot-

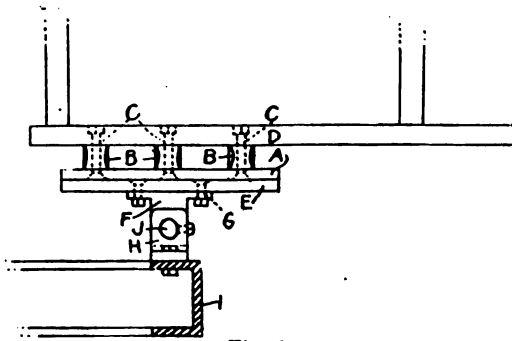

Fig. 1.

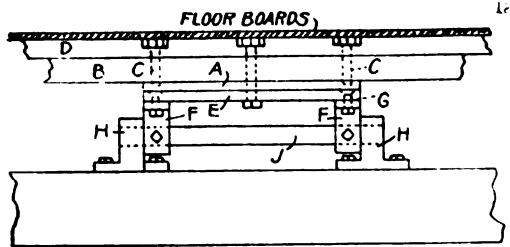

Fig. 2

Showing application of rocking fifth wheel to wagon

tom cross bars, D, of the wagon as shown clearly in Fig. 2, which is a rear view. The lower circular portion of the fifth wheel, E, has two bearings, F, bolted on each side, one end of bolt C and G being counter sunk in both circular portion of the fifth wheel. There are also two bearings, H, of the same size as F, bolted to the rear of the chassis frame I. The bar or shaft, J, placed through the four bearings gives a rocking movement to the entire fifth wheel. Bearing F has a machine bolt to hold the shaft or bar from working out of the bearings H.

## Present Body Building Methods Wrong in Principle

With few exceptions, the passenger-car bodies of today are constructed on an inherently wrong principle—and represent the sacrifice of utility to initial appearance and low cost. Consisting of a skin of metal, drawn tightly over a wooden framework, cracks and failures soon appear, and no satisfactory repair is possible. And the resale price of the car drops immediately far below its logical value.

In the old days, bodies of this type were designed for failure, hence when failure occurred it was not apparent, and did not lower the value or appearance of the car. All joints were covered by beading, and when the crack occurred, it followed the line of the joint and was hidden. But with the streamline bodies of today there are no joints, and no beading—an improvement when new and a weakness later.

At present there are three types of construction that do not possess these faults, and none of them are well adapted to the requirements of the small manufacturer desiring a distinctive body. The first is the cast aluminum body, used by the Pierce-Arrow Co., the best, doubtless, but prohibited to general use because of the cost. The second type is that used on Dodge Brothers' cars, consisting of a die pressed and welded body, but it requires a 20,000 production before it is commercially possible.

The third type is used on Marmon cars. By this scheme the body is divided into three sections, and, though eminently satisfactory, necessitated special provisions in the design. The frame must be exceptionally rigid, and the spring suspension carefully studied out. Otherwise relative motion between the body divisions will occur, the parts will work on each other, and the doors will become loose.

For the smaller manufacturers but one solution seems evident, and that is in the direction of body standardization. Several of these manufacturers, by pooling together and using a body of the Dodge Brothers type, could so reduce the production costs that a good body would be commercially possible.

There are a number of pieces in these bodies, and it is quite probable that by having just one or two special pressings three quite different appearing bodies could be made which would have 90 per cent the same parts. The economy would not be as great, but something of this sort may bring the pressed steel construction within the reach of, say, three small producers of cars.

It is mainly a question of whether the public desire cars fitted with distinctive but shoddy bodies, or with bodies that will last as long as the rest of the car.—Automobile Industries.

## No Tires Obtainable in Germany

According to Victor Van der Linde, of the B. F. Goodrich Rubber Co., who has just returned from a tour of Europe, no tires are obtainable in Germany and Austria. In Holland they cost \$350, in Spain \$125, in Russia and Italy \$100, and in England and France \$90. There is not an ounce of crude rubber in Germany, and synthetic rubber has cost about 15 times more a pound. The Kaiser is the only one in Germany using pneumatic tires. The situation in Germany and Austria and the countries bordering, with the exception of those that are at war with them, is just as bad.

Most casings are stuffed with compressed champagne corks, paper, rags and sausages made of ground cork. Some have even been filled with sand and dirt. Most automobiles have ground away their shoes and move about on rims bound with rope. There is not a bicycle tire left in Germany outside of those on military bicycles. Everything in rubber has been reclaimed for tire construction and submarine battery cells.

## Ford Output Nearing a Million

During the month of October the Ford Motor Co. made 79,675 cars. In the last six months their production was 469,135 or at the rate of 938,270 per annum. The estimated production for the year was placed at 900,000, about 3,000 per day, but there is small doubt that unless war conditions prevent that there will be more than 1,000,000 Ford cars made within the Ford fiscal year August 1, 1917, to August 1, 1918.



## Paint and Varnish

### Cold Weather Suggestions for the Paint Shop Owner

It is high time that the shop be put in order for its trial against the blustering ravages of winter. It is important that the working force be kept comfortable during the cold season, and in shape to furnish the best possible efficiency. The productive capacity of any given number of men can only be established through the medium of working conditions amply suited to the especial needs of the force. A warm, well ventilated, generously lighted shop, fully supplied with labor saving conveniences, is one of the first factors in the successful management of the painting business.

Just at this time it may happen—in fact, often does happen—that windows may rattle, the casings may prove loose, or the doors may be out of order, or the roof may leak, or some other repairs may be needed to make the shop ship shape and fit to confer upon the working force a contented and comfortable feeling. If this condition prevails now is the time, after a thorough examination of the premises, to get after the repairs and rush them through before cold weather sets in. Some reliable heating arrangement is in order, and this should be made secure and safe. Stove heat is the least desirable, of course, but such matters cannot always be controlled, and it may chance that the stove must be relied upon to furnish the heat. In this case, the use of a large stove, self feeder, is advised. It is to the advantage of the shop owner, as the man who pays the bills, to have a stove, or stoves, large enough in size to amply heat, without forcing, the desired radius of space. It is cheaper to have the stove capable, without forcing it to its capacity, of heating the needed space fully than to install the smaller one to be worked at high pressure in order to secure the necessary heat.

Steam heat for the small shop is not always available, but when it is no heat furnishes a more desirable working condition, all things considered. Usually it gives a percentage of moisture conducive to the best drying results, both in the paint and varnish departments. Hot air furnace heat, like the ordinary stove heat, is lacking in a certain percentage of moisture reckoned by experienced painters as indispensable in the rapid and uniform drying of paint and varnish. However, whatever the particular brand of heat furnished, the one supreme thing is to have it in a uniform degree. Fluctuations in the shop temperature are absolutely ruinous to correct drying conditions. The varnish room, especially, is in need of a uniform degree of heat. This matter of heat supply, therefore, is important to a greater extent, if anything, than the other factors entering into the problem of making the shop to its maximum extent productive.

Light is another problem sometimes hard to control in the provincial shop; but light is a very essential provision and should be had to the fullest possible measure. Light is a valuable agent in promoting the prompt and sure drying of varnish and all pigments; manifestly, as chemists have been able to show, light promotes the sure and certain

drying of varnish, and in conjunction with heat it forms a drying agency unequaled in all the available mediums. Make the shop as light as means at command will allow; clean the windows and invite the largest measure of natural light.

Then there is the question of artificial light which the short days force upon us; in these days even the modest shop, far removed from the great centers, may command its electric light supply, and when this is available it should not be neglected. The shop nicely lighted artificially will be in shape to yield its owner an increased revenue: during the hours when natural light is on the wane, or not to be had at all, the artificial supply comes along to give the shop force the chance of working full time at practically its normal efficiency. By all means, study this matter of light, both natural and artificial; it may help you to put your business upon a better paying basis. It will certainly enable you to work to advantage longer hours and to produce more from which profit should be derived.

Ventilation will also need some attention; not alone from the point of good health, an asset of inestimable value, but from the fact that it aids in the handling of work promptly and safely. The best form of ventilation comes from the roof, and should be brought directly therefrom into the working apartments. The elimination of foul and poisonous gases produces the correct working and drying conditions and insures for the finished work greater durability and a finer lustre.

It will be a good plan to set apart a general cleaning day during which the slicking up of the shop and the removal of all unnecessary accumulations is taken care of. It is idle to say that such accumulations should not be allowed to exist. Daily, little things will find a space in which to lodge, despite first rate vigilance, and this clean-up day will insure their removal. In fact, make the shop cleaner, more convenient, better, and therefore more profitable during the winter.

### Color Novelties

Some years ago a well known New York vehicle painter said to the writer that color novelties are very few, strictly speaking. By going into this matter a little it will be seen that our New York friend was not after all so far from the mark.

Many of the pigments going along the marts of trade are simply minor variations from the parent pigment. Not a few of the so-called novelties are produced by casting some shades or tints or hues upon a base of ordinary color with which we may be very familiar. The majority, perhaps, of the color novelties developed during the past year are the result of casting these hues, tints and shades upon not to exceed a dozen different pigments that have been known to vehicle painters for many seasons. The grinder, through the mysterious alchemy of his craft, works out these novelties which under the title that arrests the attention of men create a sensation in the world of pigments; coming down to the basis of fact these novel-

ties are, many of them, old friends under a new and fetching name, with a few additional blood lines merged into their composition. The old ingredients with which we have been on intimate terms for many years are there in force but tricked out with a pigment of opposite shade or tint. With a new name and a spark or two of new pigment the novelty gets the attention of the vehicle using public for a brief hour of adoration and presently all men are running after it. An old color given a new surface setting and then burnished with a flow of fine varnish often gets an ovation, and later a great run of favor because of its tone and color attractiveness in general.

Many of the wonderfully compelling lakes and modern reds are the old friends of former times improved and rejuvenated. They are cast upon the surface with more elaborate methods and afforded a more generous system of refinement and through this medium muster under the banner of color novelties. Color novelties, so-called, are not always the result of some organic change; neither are they always the result of color variations due to different proportions of ingredients. They quite often represent a change in the location of the color upon the surface whereby the effect produced is controlled by the contour and outline of the surface. The display possibilities of the surface have long been recognized as an active force in effecting color results almost revolutionary in their outcome. Color novelties, in fact, may be produced through the employment of varnish.

### Good Results With Rubbing Varnish

It is well to keep in mind that rubbing varnish sets up quicker than finishing varnish; even the elastic rubbing varnish, so-called, has this propensity. In the application of this class of varnish, therefore, it is a good practice to first have the surface in fine shape to receive the varnish—clean, receptive, and conditioned to the proper warmth. Then in the actual work of applying the varnish let a flowing coat, as it is so recognized, be put on. This does not mean, of course, that the same volume of material may safely be applied as would be in order if it were finishing varnish. It does mean, nevertheless, that the brush should carry an ample supply of varnish so the material may flow from the point rather than be brushed off the bristles. Then the flow of varnish will need cross brushing, using enough pressure of the brush to cause the bristles to cut through to the bottom of the flow. Next lay the varnish off in the same direction observed in putting it on; now catch up any possible drip at the edges and the work is done.

This operation should be performed in quick time for the varnish sets and dries rapidly and if it thickens up ahead of the brushing work it will ridge up. In this condition it will make hard work of the rubbing down; not only this, but some essential bulk of the varnish must be sacrificed in order to fetch the welts and ridges down to a smooth and level shape. The smoother the rubbing varnish is put on the easier it may be surfaced, consequently there will be less expense involved in the outlay.

Always apply the varnish in a warm room in a temperature not less than 70 deg. The theory that rubbing varnish can be applied in almost any quarters, so long as they are clean, is a fallacy. The very best possible conditions should prevail under which to apply varnish and give it the attention which is its due. It thrives under fine treat-

ment like any thing that has a certain amount of the human element in its composition. In rubbing the varnish it is necessary to abide by certain rules long since established as correct. The first coat of rubbing varnish will not need, nor will it stand, surfacing much in excess of that required to break down the lustre and clear away the dirt nibs. The second coat will take, naturally, a little heavier working down; as a matter of fact this is the coat upon which the bulk of the rubbing should be done. The last coat will need but a minor rub just to give it a receptive state; in flow and body it should come very close to the finishing varnish itself.

### Putty and Puttying

Perhaps a half dozen formulas cover the making of the great bulk of putty used by the vehicle painter today. The metal car body has greatly reduced the amount of putty now necessary in the painting of automobiles. Notwithstanding this fact, the use of putty has not gone out of fashion, as it was predicted many years ago. Perhaps the most generally used vehicle putty is made of three parts of dry white lead and one part whiting known as second layer whiting, which means, technically, the second layer in the settling tank. These parts to be determined by weight. Mix to the proper consistency in equal parts of rubbing varnish and coach japan. Mix thoroughly as a means of getting the minute particles woven finely into the composition of the putty. If these particles are not worked in and made a part of the putty they will break out when the pigment is being used leaving small holes which must later be filled up to make the surface intact. Hence the correctness of the practice which provides for the very thorough kneading of the pigment.

In the use of putty discretion is the one thing above all others that must guide the workman. The indiscreet workman will plaster and daub the pigment indiscriminately over the surface making its last state worse than the first. The careful, discreet man will think twice before filling a cavity. He will take in all the needs of the case. Many places indicate the need of putty, but the location, and the part that particular section of the car must play when the vehicle is in action, the force strain put upon it, etc., must be taken into account.

Putty should never be put where there are opposite movements of the surface, or, in fact, where the surface is subject to any movement at all, for it is certain to be unseated and cast out. Then the putty should be confined to the cavities actually needing it. These places should have just their needs supplied. The surrounding surface is simply damaged to whatever extent it gets plastered with the brittle pigment. It is an expense to get it off; hence the need of avoiding the application of any surplus putty. Always fill the cavity a bit flush with the surrounding surface. This as an insurance against shrinkage and to assist in surfacing to the level of the main surface. The putty glaze of which there is much used to help make the rough places smooth quickly may be made by simply thinning the putty with turpentine until it will work freely from the point of the knife.

Cornelius G. Van Alen was stricken with paralysis on his 71st birthday, September 25, and died in a short time. He was one of the prominent citizens of Northumberland, Pa., senior member of the firm of Van Alen & Co., and president of the Keystone Forging Co.

### Winter Top for Open Truck Body

The heavy storms prevailing in the fall and winter make it necessary to use some form of cover with the open type body of the commercial car, and that shown in detail herewith, taken from Blacksmith and Wheelwright, has the advantage of being removable when desired and with a minimum of effort.

Not only does the cover protect foodstuffs and other products affected by exposure to the elements, but the design includes a weatherproof cab for the driver.

The body design is for mounting on the converted one-ton Ford unit, and which has a wheelbase of 125 in., or

The window is also hinged to the cab post by the two hinges H.

#### Side Panels and Uprights

The ten roof bows C are made of 1 x 1¼ in. stock. The side panels, A, are 8 ft. by 22 in. by 1 in. There are six uprights, B, these being 2 x 1 x 42 in. The brackets, D, which are made from band iron, are 20 in number and these are shown more clearly in Fig. 1 at I. The four window posts, F, are 20 x 2 x 1 in. The window sash is constructed from 1½ x ¾ in. stock, and the two roof rails, L, are 8 ft. long by 1 x 1¼ in. Fig. 1 also shows a section, J, and a face view, K, of the side uprights, panels, etc., as well as indicate how they are secured to the side of the body.

The sketch M at Fig. 1 illustrates the inside door and window and method of attachment. These drawings have been worked out to scale and are accurate. The designer states that with the top applied to the ordinary body its carrying capacity will be increased over 100 per cent.

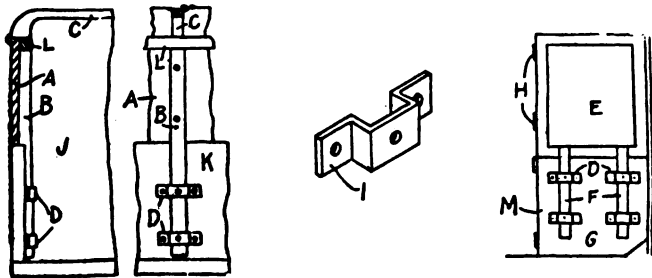

Fig. 1—Detail drawing of inside door, window attachment, etc.

35 in. in excess of the standard chassis. The original body is shown by the full lines, while the top and additional parts are indicated by the dotted lines.

#### How Door Is Made

Fig. 2 is the working draft of the top and the door window complete. Fig. 1 illustrates the parts more clearly and in detail. A is the side panel of the top and B the uprights supporting the top and holding it to the body. C illustrates the roof bows and D the brackets which are bolted to the sides of the body. The uprights B fit into the members E. E shows the additional window in the door of the driver's cab, and the two posts F are also shown. These hold the windows securely to the door.

### Sechler Entertains C. B. N. A. Executive Committee

Thos. M. Sechler, president of the Carriage Builders' National Association and head of the D. M. Sechler Implement & Carriage Co., Moline, Ill., tendered an American dinner to the members of the executive committee of the C. B. N. A. at the La Salle Hotel, Chicago, October 25. Among those present were Theodore Luth, P. E. Ebrenz, O. B. Bannister, P. P. Hunter, W. H. Roninger, W. A. Sayers, C. R. Crawford, C. P. Kimball, C. A. Lancaster, F. H. Delker, Homer McDaniel, John McGrath, E. J. Schlamp, C. C. Hull, A. C. Hill, W. G. Norman, Geo. B. Ogan, H. O. Edmunds, G. W. Huston and E. J. Baker.

Interesting addresses and reminiscences of the early days of the carriage industry were made by Messrs. Luth, Crawford, Bannister, Ebrenz, Hunter, Roninger, McDaniel and others.

It was decided to hold the 1918 convention in Cincinnati next September.

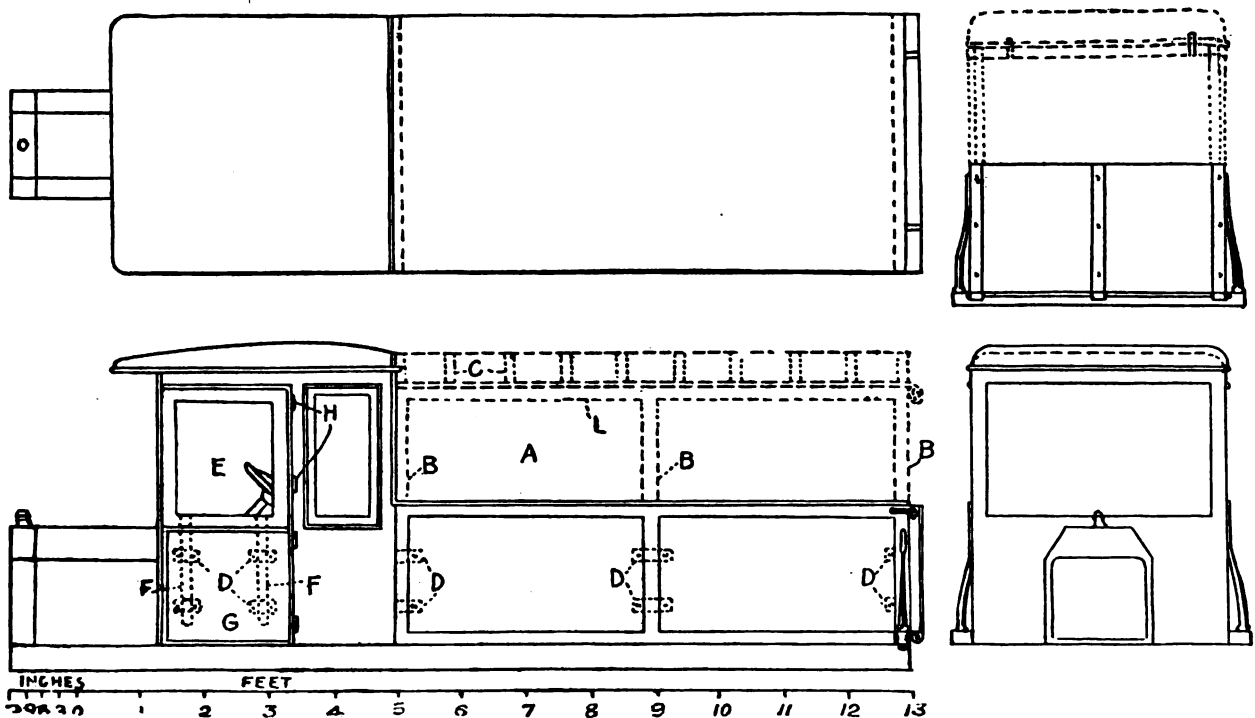

Fig. 2—Working draft of top and cover and driver's cab for open type of commercial car

### Future Supply and Consumption of Rubber

Rubber has become the basis of one of the world's premier industries, an industry in the manufacturing side of which America leads. England largely controls production through her plantation enterprises in the Far East. A view of what is going on in the whole rubber industry, production and consumption, is given in the synopsis of a talk by Frank Copeman, presiding at a meeting of the Eastern International Rubber and Produce Trust in London:

During the past two or three years the rate of increase in the production of crude rubber has been very large—from two to three times the normal annual increase. That large quantity of rubber has been absorbed, and although there is an increase in stocks as compared with last year, I see nothing at present alarming in the position. Neither, it appears, does the market, if the price of rubber counted for anything. The present rate of growth of production cannot continue. We have now in production the vast areas planted in 1910, 1911, and in 1912, and possibly a small part of the area planted in favorable districts in the early part of 1913. Since 1912 the rate of planting has rapidly decreased, and this is the factor which must be considered in estimating the increase in the world's production of rubber during the next few years. The new plantings during the years from 1913-1916, inclusive, are estimated by Rickinson—and the estimate is probably as near correct as it is possible to get it—at 163,091 acres, 116,696 acres, 81,246 acres, and 52,000 acres respectively. Represented by percentages over the preceding year, that means 11.2 per cent, 7.2 per cent, 4.7 per cent, and 2.8 per cent respectively. We must allow for the increase of yields per tree due to growth, but there is a limit to that increase.

We hear very much about the large consumption of rubber due to the war. I admit it is large, but question if the growth in consumption is due to the war.

The roads of the world eat up the greater part of the world's rubber. Motor transport was making gigantic strides before the war, and after the war will make greater strides still. If the consumption of rubber in the form of tires—solid and pneumatic—is great in regard to military uses, will it not be far greater than it has been in connection with commercial uses?

There are few industries that have been more adversely affected by the war than the rubber industry.

We may assume that Germany obtained direct and through neutral countries small quantities of rubber since war commenced, but her stocks and supplies are by now exhausted. The blockade has become tighter, and when the Board of Trade returns for 1917 are published, I expect to find that the exports and re-exports of rubber to Sweden and Denmark will be nearer the figures of 1914 than those of 1915 and 1916. Further, Germany's old rubber goods have been reclaimed and reclaimed, until nothing but filling is left. After the war, Germany and Austria must come into the market as substantial buyers. The pre-war consumption of rubber by Germany and Austria was at least 22,000 tons per annum. I do not say that these countries will require such a large quantity in the first post-war year, but urge that whatever our opinions may be with regard to trading with Germany after the war, Germany will require, and will obtain, large supplies of rubber soon after peace is proclaimed. So far, all the

rubber produced has been sold at prices which, if not good, were at least remunerative. America takes over 60 per cent of the world's supply of rubber, and during the past two years has been importing from the east by direct lines of steamers. America wants rubber, and so long as she wants it she will take care that she gets it, and will be prepared to pay a reasonable price for it.

### "The Kiln Drying of Lumber"

This is a new authorized work covering the entire subject, by Harry Doland Tiemann, M.E., M.F., in charge Section of Timber Physics and Kiln Drying Experiments of the U. S. Forest Service; Special Lecturer in Wood Technology and Forestry, University of Wisconsin, Forest Products Laboratory, Madison, Wis.

The value of technical knowledge of kiln drying is self evident. This book gives the reader the most recent and most clearly expressed information. The United States is taking a lead in the adoption of the kiln drying method and this volume will increase our lead. It is a practical as well as a theoretical treatise. The text and illustrations guide the way to the most efficient methods of work.

Kiln drying improves the condition of the wood for the purpose for which it is used; it reduces losses from warping, checking, case-hardening and honey-combing that occur in air drying; it reduces the interest charge, the fire risk, the weather attacks, by reducing the period necessary to carry wood from the time it is cut to that when it is fit for use; it reduces the weight and thus facilitates handling and shipping.

The present losses in preliminary air drying can be reduced by kiln drying from 12 per cent for hard woods and 5 per cent for soft woods to 2 per cent. There is a possible annual saving of \$17,178,000. The book contains upwards of 300 pages, has 16 tables and 55 illustrations. The price is \$4. Published by J. B. Lippincott Co., Washington square, Philadelphia, Pa.

### Salon Show Dates

The annual salon exhibition of exclusive American and foreign cars in New York City will be held January 2 to 9, inclusive, in the grand ballroom of the Hotel Astor; the Chicago show will be held from January 26 to February 2, in the Elizabethan room of the Congress Hotel. Both will be held under the auspices of the association, the Automobile Salon, Inc., and under the same management. New York reservations have already been made for White, Locomobile, Daniels, Murray, Simplex, Cunningham, Biddle, Rolls-Royce, Lancia, and Fergus automobiles and Brewster, Rubay and Brooks-Ostruk bodies. At the association's annual meeting held recently in New York, E. Lascaris was elected president, Thomas E. Adams and Leon Rubay vice-president, and Robert W. Schuette, secretary-treasurer.

### Sheldon Parts in New York

The Chadwick-Delamater Corp. has been appointed as representative of the Sheldon Axle and Spring Co. for the distribution of parts in New York City and vicinity. The company's service station is at 159 West 24th street, New York City, and is well equipped to take care of repairs. A complete stock of parts will be carried for the purpose of co-operating with dealers and truck users, enabling them to make replacements on short notice.

## The "Taylor" System

Away back in the eighties Frederick Winslow Taylor, the originator of what is known as the Taylor system of shop management, began the series of investigations which made him famous. He saw that there was not only great unevenness in the quality of management of great businesses, but also in the quantity and quality of work done by different grades of workmen. Though first class workmen could do four times as much work as the average man, both received the same rate of pay. This system discouraged efforts to excel. He aimed to alter it. He adopted for his motto, "High wages and low labor cost." To get these he analyzed the motions of workmen, taught them to cut out those that were useless and to economize effort. He provided the best machines and tools and insisted that they should be used to the limit of their capacity and speed, and to secure his ends made it a rule never to employ any man who on piece work could not earn at least 60 per cent more than the average rate paid to the ordinary workman.

Taylor's method was to divide each man's work into its elements and find out the time required for each element, and base his estimate of what a man can do upon the record so made. For example: Men loading pig iron into railway trucks were timed. The elements were (1) picking up a pig, (2) walking on level ground to the truck, (3) walking up a plank, (4) putting down a pig, (5) returning to the pile. The average work done per man was to load 12 tons per day. From his analysis he concluded that 45 tons could be done. He fixed a piece rate which would secure a 60 per cent increase in wages to men loading, by his methods, 45 tons per day. It was accepted. He would not keep a man who could not perform the task. The work became popular. The high wages attracted first class men, and the system was gradually extended to all other classes of work. Taylor never had a strike.

Another innovation introduced by Taylor was the employment of what he calls "functional foremen." The duties of foremen under the old system were so many and varied that men with the necessary qualifications to perform them were rare. Taylor had accumulated a vast amount of classified knowledge of workshop practice, capacities of machines, methods of working them, and properties of tools that were useless, if workmen were permitted to choose their own methods. He did away with the ordinary foremen who controlled small groups of men, and put in their places functional foremen, of whom there were eight kinds. Four were on the office staff, namely: (1) Order of work and route clerk, (2) instruction card clerk, (3) time and cost clerk, and (4) shop disciplinarian; and in the shop he employed (a) gang bosses who prepare work up to the time it goes into a machine, (b) speed bosses who see that proper tools are used and right methods employed, (c) inspectors who are responsible for quality of work, and (d) repair bosses who see that machines are kept in order.

Workmen under Taylor's system keep the records of their own work and time. Their cards go to the proper clerks in succession. The last to get them is the pay clerk, so that wages cannot be paid until all information required by other clerks is supplied; therefore little trouble arises from the time cards.

Machines have multiplied the power of human hands and increased production. Taylor's methods have added

to the capacity of machines by increasing the efficiency of labor, creating new openings for brain workers, and raising the intellectual and living standards and earning power of workmen.

## S. A. E. Nominations for 1918

C. F. Kettering, vice-president of the Dayton Engineering Laboratories Co., has been selected to head the Society of Automotive Engineers next year, along with an exceptionally strong supporting ticket. David Beecroft is named as first vice-president, and C. B. Whittelsey, vice-president and factory manager of the Hartford Rubber Works Co., treasurer.

Next year the varied activities of the membership are to have direct representation in the form of five second vice-presidents, representing the five grand divisions of automotive activity. C. C. Hinckley, head of the Hinckley Motors Co., has been selected to represent automobile manufacturing interests; aviation, G. H. Houston; tractor, Fred Glover, vice-president of the Emerson-Brantingham Co.; marine engineering, H. R. Sutphen, vice-president of the Submarine Boat Corp.; stationary and farm engines, H. R. Brate.

Nominees for members of the council to be elected are three in number: C. M. Manly, vice-president and chief engineer Curtiss Aeroplane & Motor Co.; J. V. Whitbeck, engineer Chandler Motor Car Co.; and C. S. Crawford, chief engineer and assistant general manager, Premier Motor Corp.

## Standard Widths for Wagon Tires

As a result of a series of exhaustive tests on earth and gravel roads the following loads and widths of tires are recommended by the U. S. Department of Agriculture. It is also recommended that the widths of tires be adopted generally by manufacturers of wagons.

Type of Wagon.	Gross Weight, Loaded	Width of Tire, Inches.
One-horse wagon .....	2,000	2
Light two-horse wagon.....	3,500	3½
Medium two-horse wagon.....	4,500	3
Standard two-horse wagon.....	6,800	4
Heavy two-horse wagon.....	7,500	5

It is held that these five types should be sufficient to meet the needs of all farming operations and general work, except the heaviest trucking and certain specialized hauling which is likely to be confined to city pavements. It is suggested that a name be adopted for each of these sizes and that wagons be designated, not by the sizes of skein, but according to their gross load capacity.

## Vest Pocket Information on Du Pont Companies

There has just been issued a handy little booklet which contains a list of all the products manufactured by the E. I. du Pont de Nemours and associated companies, namely Du Pont Chemical Works, Du Pont Fabrikoid Co., The Arlington Co. and Harrison's, Inc.

Of course this booklet does not indicate who uses the products or how used, as does the Du Pont products book, but it will no doubt prove of interest as well as of value to many mercantile and industrial men. It is small enough to fit in a busy man's pocket. It will be sent upon application to the home office at Wilmington, Del.



## Electrically Heated Enameling Ovens at Ford Plant

The Ford assembling plant in Chicago is equipped with electrically heated enameling ovens. According to the Electrical Review 108 heaters are installed in the main oven, by which a temperature of 450-475 deg. F. can be maintained. The enameling department is on the sixth floor. The oven is built in two sections, a pre-heater and the principal heater. It has a cross section 52 in. in width and 85 in. in height. The main oven is 78 ft. 8 in. long and the pre-heater 30 ft. The oven structure consists of a steel frame with sheet metal covering and a heavy asbestos lining, making the walls 6 in. thick.

The oven proper contains 108-220 volt, three-phase heating units, aggregating 160 k.w. These consist of nichrome ribbons mounted on porcelain insulators. The heaters are arranged along the floor and both sides of the oven for a distance of 40 ft., the length of what is called the heating section. An automatic controller maintains the temperature between 425 and 475 deg.

The metal parts being enameled are first dipped in a 200 gal. tank of asphaltic enamel, then hung by hooks upon an endless-chain conveyor, which is carried by a sprocket wheel at each end and in the top of the oven. This conveyor makes a continuous circuit; for instance, carrying a metal part first through the pre-heater, then by a semi-circular turn into and through the main oven, thence by another turn to the starting point, where treated parts are taken off and those to be treated are hung upon the conveyor. This loading and unloading place is an open space, outside the ovens, where the dipping tanks are situated. The sprocket wheels, on which the chain conveyor rides, are driven by a 3 h.p. variable-speed motor, stationed on top of the oven. The speed of the conveyor is 18 to 36 in. per minute. Metal parts are dipped in enamel and then carried around the circuit, then taken off and dipped a second time and passed through the ovens again; and at the end of the second circuit the enamel is absolutely dry and hard and the parts are ready for assembling. The temperature of the pre-heater is maintained at 225 deg.

Ventilation of the ovens is regulated by two 15 in. smoke stacks at different points in the roof, by a rotary suction fan driven by a 1 h.p. motor, and by pipes at the entrance end of the oven.

Each day's run of metal parts through the enameling ovens amounts to 50,000 to 60,000 lbs. per 24 hours, at a cost of 6 to 7 k.w.-hr. per 100 lbs. This material is made up of twelve different kinds of parts, and the equipment is ample for the enameling required in the assembling of the 72,000 automobiles turned out here in one year. By the use of electric enameling ovens there is a pronounced saving in labor costs, as compared with those costs when gas-heated ovens were used. It is understood that with electric ovens the labor costs are only about two-thirds as much as when gas ovens were in use. Another phase of economy is the speed of operations and the uniformity and steadiness at which heat may be maintained. The run of the circuit through the ovens requires only 30 to 40 min.

The ovens, conveyor system, and equipment for applying electric heat to the conditions required were designed by the Ford Motor Co., at Detroit. The initial installation was at the Chicago assembling plant; the second was built at the Columbus, O., branch, and the third is being installed at Minneapolis. The ovens and their equipment

herein described are regarded as standardized for other branch plants, and it is probable that there may be a duplication of this installation at each of the 30 to 40 branches of the Ford Motor Co. throughout the country.

## How Fords Have Multiplied

Figures dealing with the Ford car are always of interest to owners. The annual report of the Ford Motor Co. for the fiscal year ending July 31, 1917, shows an increase of \$26,754,560 in total assets and a reduction of \$7,420,381 in the amount of cash on hand and in the banks. The total business transacted during the year is between \$350,000,000 and \$400,000,000, as compared with a gross business of \$206,867,347 for the preceding year. The company produced 785,432 cars, as against 533,291 for 1916. The schedule for 1918 calls for 900,000 machines, and the company is now producing 2,700 a day and anticipates a production of 3,000 daily. The record number of cars for a single day during the year just closed was 3,310.

The production figures for the past 14 years are of interest and show how the Fords have multiplied. The figures follow:

Year	Cars Made and Sold	Increase or Decrease	Daily Average
1917	785,432	+ 251,511	2,618
1916	539,921	+ 255,708	1,816
1915	308,213	+ 59,906	1,027
1914	248,307	+ 83,855	827
1913	164,452	+ 95,908	545
1912	68,544	+ 30,078	228
1911	34,466	+ 15,802	115
1910	18,664	+ 8,057	62
1909	10,607	+ 3,209	35
1908	6,398	— 2,025	21
1907	8,423	+ 6,284	28
1906	1,599	— 96	5
1905	1,695	— 13	5
1903-4	1,708		

The Ford company has also changed its dealer policies and in place of making the usual one-year contract, as has always been done in the past, it is now making contracts with agencies which stipulate the yearly allotments but which may be terminated at any time.

## Kratzer Carriage Co. Busy on U. S. Truck Bodies

C. S. Walker, president and treasurer of the Kratzer Carriage Co., Des Moines, Ia., reports that while that company has not made many buggies the past year, it has nevertheless been very busy making bodies for motor trucks, both light and heavy. One of the accomplishments was a trainload of U. S. Standard Class "A" bodies including cover, front seat buck and top over front seat, made according to the latest revised blue prints, and this particular shipment, fully mounted, went to the national cantonment at Alexandria, La.

## Ford Smelting Plant to Be Ready in 1920

At the present rate of progress it is estimated that the Ford smelting plant will be completed and in operation by the first part of 1920. Much of the output of this plant will doubtless be used by the Ford Motor Co. and by the tractor plant of Henry Ford & Son. The buildings at the plant are practically without exception of concrete and brick construction, cover a tract of land nearly a mile long, and will employ, it is said, about 100,000 persons.

## Information to Applicants for Enlisted Ordnance Corps

### What It Is

The Enlisted Ordnance Corps, National Army, into which the Ordnance Enlisted Reserve Corps has been merged, is charged with the supply, maintenance and repair of all cannon and artillery vehicles and equipment; all machines for the service and maneuver of artillery; all small arms, ammunition, harness, motor trucks, motorcycles, tractors and railroad cars; in fact, it is the army behind the army, commonly known as "Service of the Rear."

### Type of Men Wanted

There is a place for practically every man who knows a trade in the Enlisted Ordnance Corps. Machinists, mechanics, plumbers, painters, carpenters, canvas workers, auto mechanics, saddlers, blacksmiths and wheelwrights are especially needed at this time.

Applicants must be between 18 and 40 years, citizens or declarants, and be able to speak, read and write the English language, should have no absolute dependents, and must be able to pass a physical examination conforming to that prescribed for the regular army.

### Place and Type of Service

If accepted for enlistment, men will ordinarily be sent to an arsenal school for a period of instruction, on completion of which they will be assigned to detachments, units or organizations, with ultimate service abroad. Previous military training, while preferable, is not essential, as men will continue the work which they pursue in civil life.

### Pay and Grade

In view of the importance of their work a large number of men will serve as non-commissioned officers. Original enlistment is required as private, but later courses of training or special qualifications quickly lead to higher grades. Pay ranges from \$30 to \$97.20 a month, depending upon demonstrated ability and place of service. Men enlist for duration of war only.

Free quarters, rations, clothing, bedding, medical attendance, etc., are provided.

### Relation to the Draft

Men registered under the selective service law may voluntarily enlist prior to the posting of their names by their local boards. No man who has been called to appear for physical examination is eligible for enlistment in any branch of the military service. In case such men do enlist the department under which they have enlisted will be requested to discharge them and direct them to report to their local boards.

### How to Enlist

Get application blank by writing to Chief of Ordnance, Enlisted Personnel Division, Washington, D. C. Fill it out, return to chief of ordnance, and if there is an opening for you at the time, authorization will be sent you to enlist at the nearest recruiting station, and if accepted there, free transportation will be provided to place of service.

During the last three years 12,380 motor cars have been imported into New Zealand, of which only 1,486 were classed as pleasure cars, the others being for general utility purposes. It is stated that the cost of the motor cars imported during the three years averaged \$768.90 each

## Rasp for Soft Metal

The rasp shown in the accompanying sketch will be found very useful in cutting down aluminum, solder and other soft metals, as it does not clog up and cuts very quickly. Metal-pattern makers will find it very handy in trimming of solder on gated work. It is easily made. A file of suitable shape is softened, and then the teeth are

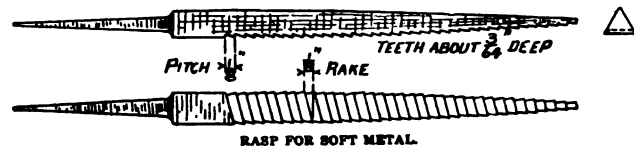

filed to the dimensions given, a 6 in. half-round file being used for this purpose. It is best to leave the rasp soft, as it keeps the edge for quite a satisfactory length of time, and can be quickly filed up sharp again.

This tool is best made from three-cornered, square and half-round files; the half-round and round will be found very useful in getting around a radius. The file may be bent, if desired, about 2 in. from the point, which facilitates getting at sunken portions of the work.—H. Coomber, in Brass World.

## Join the Civic Ranks as a Technical Guildsman

In connection with or in response to the call of the President, i. e., men skilled in any line of science or mechanical or electrical or chemical or ordnance or explosives or mining or ship building or railroad or motors or metallurgy or building of aeroplanes or water supply or sanitation, etc., is especially invited to the need of the army for such (young) men—aged 18 to 40—in sundry branches of technical troops concerning which write for literature to Major J. E. Bloom, U. S. A., 266 Market street, Newark, N. J.

Any technical "men who are exempt" or who from any cause cannot "volunteer," can yet efficiently co-operate by forming technical patriotic educational guilds in their several industries or home neighborhoods, especially to look after the welfare of their men in the service, and to give them the opportunity of obtaining technical assistance, opinions and advice from home, in any war industry, from time to time.

## Coal Gas as a Substitute for Gasoline

By using coal gas as a substitute for gasoline, English motor bus companies are said to have succeeded in reducing their fuel cost per mile from 8 to 3.3 cents, with gasoline selling at 61 cents a gallon and gas at 61 cents per 1,000 cubic feet. The only change made in the motor is the fitting of a butterfly valve in the air intake pipe for the regulation of the air supply, which allows the engine to draw the gas in the correct quantity according to load and speed. It is claimed that when using gas the engine is cleaner and the valves do not require grinding so often. The gas is drawn from the main into a canvas bag with an inner layer of rubber, shaped like a mattress, which is strapped to the top of the motor omnibus or to the rear of the automobile. This bag is connected with the induction pipe, and the engine is worked by the suction process in the same manner as the ordinary gasoline vapor induction. Because of the bulky container necessary for the gas, this fuel has proved unsatisfactory for small cars.

## Tests in Kiln Drying Woods for Airplanes

When the United States entered the war the need for wood to build airplanes quickly created a difficult problem. Most of the air-seasoned wood available had been bought for airplanes for the allied nations abroad. Thorough air-seasoning of such stock requires from one to three years, according to the size and kind of wood. Kiln-dried stock under the methods ordinarily used has frequently proved unsatisfactory and for that reason airplane manufacturers have been reluctant to use it. If the needs of the fighting forces were to be met adequately and without prolonged delay, it was essential that methods of conditioning should be available in which full confidence could be placed.

Long before this situation developed the Forest Products Laboratory of the Forest Service, at Madison, Wis., had been making a scientific study of the drying of wood, and had developed a method of drying which has been very successful with all the woods tried. Several kilns have been built at the laboratory for experimental purposes and a number of demonstrations made in commercial kilns. Ash and spruce are the woods most in demand for airplane construction and anticipating the present situation the Forest Service secured a shipment of partially air-seasoned ash and spruce plank for preliminary tests.

This material was kiln dried without injury. Later thoroughly green Sitka spruce, white ash (northern and southern), white oak, Douglas fir, western white pine, and mahogany were secured in the log for testing. The spruce and ash logs were cut up and the green material from each species divided into three matched groups. One group of each species was tested green, another has been set aside to be tested when it has air dried, and the third group was kiln dried, trying several methods, and then tested. Only the results of tests on the spruce have so far been analyzed. Comparison with standard tests which had already been made shows that Sitka spruce can be kiln dried from the green condition with no more, perhaps less, injury to its mechanical properties than by air seasoning. Definite specifications have been prepared for kiln drying spruce green from the saw for airplane construction, and, if rigidly enforced, they will insure kiln dried stock of this species equal to air dried stock.

A preliminary study of propeller construction has shown the need of such information on propeller woods. The testing of the ash and other species now on hand, which include several propeller woods, is being pushed as rapidly as possible, and there seems reason to expect as favorable results as for the spruce.

## Canada's Purchases of American Automobiles

During the six years ended March, 1917, Canada's imports of automobiles from the United States amounted to more than \$40,000,000. In 1912 the amount was \$6,077,497; in 1913, \$9,233,171; in 1914, \$6,459,346; in 1915, \$4,532,138; in 1916, \$5,790,498; and in the year ended last March, \$8,555,475.

Canada's imports of automobile accessories from the United States during the same periods amounted to nearly \$20,000,000, made up as follows: In 1912, \$854,000; in 1913, \$762,321; in 1914, \$3,965,173; in 1915, \$2,139,552; in 1916, \$4,693,003; in 1917, \$7,173,423.

The imports of automobile tires amounted to about

\$7,000,000. The annual amounts were: In 1912, \$666,411; in 1913, \$1,507,916; in 1914, \$1,263,382; in 1915, \$1,044,592; in 1916, \$1,389,400; in 1917, \$1,217,532.

The 1913 reports showed that the number of registered cars in Canada had increased by 16,780, or 38 per cent, over the 1912 registration, and in 1914 the increase was 22,070, or 36 per cent, over 1913. After three years of war it is estimated that Canada this year is purchasing 100,000 new motor cars, almost five times as many as in 1914.

The motor car in Canada is more and more coming to be considered a commercial necessity. It has aided in the movement of troops, facilitated the transportation of war material, increased the efficiency of the farm, aided in the quicker movement of all things pertaining to business, and has been a great economic factor in the development of general business.

More cars have been sold in western Canada during the past two years than in the east. British Columbia, with a population less than 500,000, scattered over wide areas of mountainous country, has automobiles in the proportion of one to every 78 of the population.

The trend of the buying is shown by the fact that fully 15,000 of the increase of 23,000 cars in Ontario were priced under \$1,500. A conservative estimate of the amount of money invested in private cars in Canada places it at \$135,000,000.

Many large firms in the United States have established branch factories in Canada on account of the high customs duties. The automobile body and machinery are imported separately and afterward assembled there.

## Organized to Distribute Commercial Bodies

The Commercial Motorbody Corp. has been organized in New York to act as a distributor of commercial motor bodies. According to its present plan it will represent nearly 100 companies and will issue a catalog showing 400 different types, so that a dealer's customer may have a choice of everything made in the entire trade. The catalog will be issued about January 1. The bodies range all the way from small delivery types up to heavy dumping bodies. Warehouses are to be operated in Chicago, Detroit, New York and other centers. The offices of the company are at 50 East 42d street.

The officers are: President, P. H. Patriarche; vice-president, Charles M. Eaton, of Raymond Pynchon & Co., bankers; treasurer, Paul D. Langdon, H. L. Horton & Co.; secretary, F. Gates Porter, Pynchon & Co.; directors are the officers and W. A. Harriman, vice-president, Union Pacific; T. W. Cole, president Cole Paper Co.; J. K. Robinson, Jr., president Ox Fibre Brush Co; Frederick A. Wagner, of the law firm of Parker, Davis & Wagner, New York.

## Studebaker Group Nearly Finished

The Studebaker Corp. anticipates that within a few months at most its entire new \$2,000,000 plant at South Bend will be completed. A new four-story dry kiln is already in use for seasoning the woods used in Studebaker automobiles. Another of the group reported as far nearing completion is the power plant. This will add almost 10,000 square feet of space. Like the other buildings it is of reinforced concrete. The two huge brick smokestacks alone cost \$10,000.

### Rusty Springs Best for Bad Roads

Rusty springs materially aid in damping out recoil because of the extra friction between the leaves and are therefore better for very rough roads and high speed, according to the conclusion reached at the monthly meeting of the Pennsylvania section of the S. A. E., held at Philadelphia, October 25; but for moderate speeds on smooth roads such as city pavements, well lubricated springs are best. The friction of rusty leaves, however, also acts to stiffen the spring and therefore cannot be looked upon as a solution of the problem. It was the sense of the meeting that a spring should be as soft as possible in order to absorb and not transmit road shocks, and damping action should operate only on the recoil. The consensus of opinion appeared to be that no spring as yet designed realizes the ideal; that regardless of type, elliptic, semi-elliptic, cantilever, platform, or otherwise, the spring unaided, is not capable of giving that degree of riding comfort which may be considered ideal.

The three factors affecting riding comfort are (1) tires, which absorb small vibrations and bumps of perhaps 2 or 3 in.; (2) springs, which absorb all the larger shocks; and (3) upholstery, which absorbs the multitude of small shocks and vibrations.

John Wilkinson, vice-president of the H. H. Franklin Mfg. Co., advocated elliptic springs as being the logical type. The only disadvantage of this type was due to the rather long degree of slip necessary in the universals. Elliptic springs permit a certain amount of side sway, but this is desirable for easy riding to prevent passengers being thrown violently from side to side on bad roads.

Wilkinson brought up the question of rust improving riding qualities. It was his experience that an old car always rides better than a new one, and in order to make the new car approximate the old in riding comfort a plan had been worked out to enamel between the leaves of the springs to increase the damping action. This worked out well. He stated that the less the deflection of a spring per inch the greater would be the riding comfort. He is at present using 160 lbs. to the inch in open cars and 210 lbs. in closed cars; the clearance with five passengers is 5 in.

Walter C. Keyes, chief engineer of the Standard Parts Co., Cleveland, stated that there is no outstanding superiority in the riding qualities of any particular type of spring. "If any one type had proven consistently superior," he said, "it would have been adopted by car makers, just as the bevel gear has." He illustrated his talk with a series of lantern slides from photographs made at night to demonstrate spring action. These showed a series of wavy lines made by small lamps in various places on the car as it was driven in front of the camera. A number of different makes of cars were tested under varying loading and speed conditions over a standard bump. At low speeds—3 to 10 m.p.h.—movement of the car body was considerable; this decreased as the speed was increased up to 20 m.p.h., which appeared to be the best speed for greatest riding comfort, regardless of make of car or loading. Above 20 m.p.h. and up to 30 m.p.h. body movement increased.

### Bela Body Co. Gets Big Order

The Bela Body Co., Framingham, Mass., is enlarging its plant and hopes to be able to double its capacity by next spring. In addition to building special bodies for the

Liberty Motor, Packard, Winton, Mercer, Studebaker and a great many other cars, the company in the past four months built 350 sedan bodies for the Franklin company and now has an order from that company for 750 more bodies of the same type.

### Norton Co. Buys 205 Acres

The Norton Co., Worcester, Mass., abrasive and grinding wheel manufacturer, which has made large extensions to its plant during the past three years and has built a notable industrial village, has bought 205 acres adjoining its present tract to provide for future plant expansion and more workmen's homes. The company has no plans for immediate new construction.

### Convertible Body

A body that is convertible into a five or seven-passenger touring car or a two-passenger roadster by a simple operation that requires but two minutes, is the invention of a native Argentinian, but now an American citizen, named

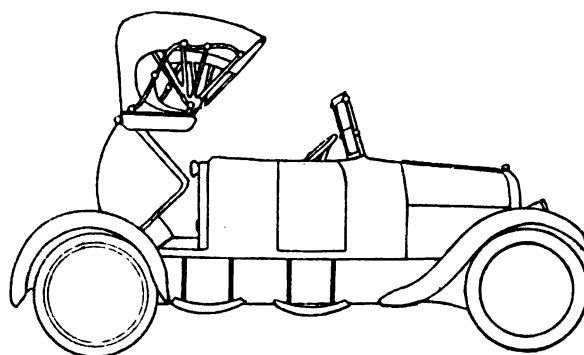

Carrm. The line drawing makes explanation unnecessary. The model which was exhibited at the offices of the American Motors, Inc., New York City, suggests a similar production in a horse-drawn vehicle which was exhibited for a number of years at the carriage builders' conventions years ago.

### Death of W. A. Sayers

W. A. Sayers, president and general manager of Sayers & Scovill Co., Cincinnati, O., died at his home in Glendale, November 12. He was born in New York City, March 2, 1850, went west and located in Cincinnati when 16 years old. He learned the carriage business in his father's shop and in 1876 entered into business for himself and took for his partner Andrew R. Scovill, and founded the firm of Sayers & Scovill, engaged in the manufacture of carriages. At the death of his partner, A. R. Scovill, in December, 1907, the corporation of the Sayers & Scovill Co. was formed. Mr. Sayers always has been actively engaged in the business. He was noted for his geniality and kindness to his employes. He is survived by his widow. He was a member of the Business Men's Club, Carriage Maker's Club, and a member of the executive committee of the Carriage Builders' National Association.

Cablegram from American consul general, Sydney, October 10: Importation motor cars ordered prior August 10 permitted provided cars shipped by December 31, 1917. In case of importation of cars not ordered prior August 10, each car must be accompanied by two chassis before it will be admitted into Australia.

# Vehicle Industry News in Brief

## Truck Builders

**J. T. Wilson Co.**, Detroit, announces a new five-ton truck the first of the year.

**Oneida Motor Truck Co.**, De Pere, Wis., is rapidly completing the construction of its plant.

**Gary (Ind.) Motor Truck Co.** has doubled its capital stock by issuing \$75,000 of preferred.

**Redden Motor Truck Co.** will shortly be transferred to Jackson, Mich. The accounting department has been there three months.

**Western Truck Mfg. Co.**, Chicago, Ill., has been incorporated, capital \$25,000, by George H. Burns, Agnes Fleming, Jacob Samuelson.

**Mackey Motor Co.**, Akron, O., has been capitalized for \$250,000 to manufacture a four-wheel drive automobile. J. C. Mackey is president and manager.

**Triangle Motor Truck Co.**, St. Johns, Mich., will erect an addition to its plant which will be 70 x 235 ft. and one story high. The structure will cost \$15,000.

**Cannonball Motor Co.**, Texico, N. M., recently incorporated, announces plans for the erection of a factory to manufacture automobiles, farm tractors, trucks and parts.

**Maccar Truck Co.**, Scranton, Pa., will erect a one-story power plant addition, about 30 x 42 ft., to cost \$10,000, to its new plant now in course of construction at Providence road and Gilligan street.

**Premier Motor Co.**, Indianapolis, has obtained a \$15,000,000 contract to build motor trucks for the government. E. W. Steinhart is vice-president and general manager. The company will increase its force to 2,500 men.

**Peerless Motor Car Co.**, Cleveland, O., is turning out trucks at the rate of 15 a day for the British government. Extensions have been completed to expand the passenger car department and a warehouse 48 x 400 ft. is in course of construction.

**Briscoe Motor Corp.**, Jackson, Mich., will manufacture a one-ton truck with many parts interchangeable with the Briscoe Model 24 pleasure car. It will sell for about \$1,000 and will have a wheelbase of 132 in. It will be equipped with a starter and windshield.

**Oxford Truck Mfg. Co.**, Newark, N. J., has been incorporated with a capital of \$125,000 to manufacture motor trucks and other vehicles. William W. Schofield and Geo. W. Nuse, Newark; John J. Bush, New York, and Ernest B. Raunser, Brooklyn, are the incorporators.

**Lincoln Motor Truck Co.**, Anderson, Ind., has been organized to manufacture motor trucks and will occupy part of the factory buildings of the Spring Steel Fence Co. The directors are Robert J. Walker, Michael G. O'Brien, Anderson; and Ernest Bartsch, Detroit.

**Crescent Motor Truck Co., Inc.**, New York City, of which Jos. W. Brooks is president, will manufacture a

1,500 pound light delivery truck that will be assembled from high grade parts. Temporary headquarters of the company are located at 1457 Broadway, New York

**Premier Motor Corp.**, Indianapolis, Ind., has obtained a \$15,000,000 contract to manufacture government motor trucks, according to statement issued by E. W. Steinhart, vice-president of the company. Over 2,500 men will be employed at the plant and work will begin in 30 days if the proper tools and machinery can be obtained.

**Locomobile Co. of America**, Bridgeport, Conn., has received a government order for Riker trucks and equipment amounting in value to nearly \$2,500,000. The company is at present working on government orders and it is believed that an extension of the plant and working force will be necessary to produce the additional work.

**Republic Motor Truck Co.**, Alma, Mich., will manufacture 40,000 trucks during the coming year, according to the plans of the production department. In order to care for this increased production, additions to the plant are new under way which will increase the shop floor space by 70,000 sq. ft. At present 1,500 men are employed.

**Titan Truck and Tractor Co.**, 843-849 Thirtieth street, Milwaukee, recently incorporated with a capital stock of \$100,000, has changed its corporate style to the Titan Truck Co., having abandoned its original plan of building tractors, at least for the present. Joseph C. Millman is president and general manager.

## Body Builders

**Auto Body Co.**, Lansing, Mich., is making changes in its machine department.

**Meridian Mfg. Co.**, Indianapolis, is now producing 19,000 bodies and taking on new contracts.

**Texas Wheel and Body Co.**, Dallas, has been incorporated with a capital stock of \$10,000 to manufacture wheels and bodies for vehicles.

**Piedmont Motor Car Co.**, Lynchburg, Va., is planning for extensions to its plant to include a department for the manufacture of automobile bodies.

**Olympian Motors Co.**, Pontiac, Mich., has purchased the equipment of the Meridian Mfg. Co., Indianapolis, Ind., and will build bodies for its own automobiles.

**Universal Body Co.**, Jonesville, Mich., has purchased the Deal Buggy Co. plant at Alma, Mich., and expects to have 100 men working within the next six months.

**Otto A. Lawton** has been elected treasurer and director of the Bela Body Co., Amesbury, Mass. He is a director of the H. H. Franklin Mfg. Co., Syracuse, N. Y.

**Detroit Weatherproof Body Co.**, Pontiac, Mich., has secured W. H. Taneyhill as sales manager. He was general sales manager of the Scripps-Booth Motor Car Co.

**Appleton (Wis.) Auto Body Co.**'s new manufacturing plant is now well under way. It will be 50 x 237 and 40 x

50 ft., L shaped, of concrete and brick, and will cost about \$25,000 with equipment.

**Blue Ribbon Body Co.**, Bridgeport, Conn., has established a New York sales office at 1823 Broadway. Charles Baasch, formerly with the Springfield Body Corp., has been appointed manager of this office.

**Milburn Wagon Works**, Toledo, O., is now doing the finishing work on all Oldsmobile closed cars and at present is turning out 15 bodies a day. The chassis are shipped from Lansing to Toledo, where the bodies are added and completed.

**Jones Motor Car Co.**, Wichita, Kas., will enter the truck body manufacturing field. This will also include the construction of limousine, coupe, and all kinds of enclosed bodies and tops, also the manufacturing of fenders, upholstery, etc., and bodies for trucks and commercial cars.

**Heil Co.**, Milwaukee, Wis., is building additions to its plant which will make it one of the largest makers of motor dump truck bodies in the world. The main addition will be a steel and brick shop, 130 x 120 ft., equipped with electric welding machinery, a three-ton and a five-ton electric crane to cost about \$100,000 complete. This shop will be devoted exclusively to the production of motor truck bodies by the electric welding process.

**Dunham Body Co.** has been organized to succeed D. B. Dunham & Son, builders of automobile bodies, Newark, N. J. The officers of the new company are: President, Frederic W. Dunham; secretary and sales manager, Lindsay Dunham; treasurer, Charles W. Oathout. In keeping with the reorganization of the company, radical changes are also being made at the plant, located at Avenue B and Miller street. A new building is at present being constructed.

**Ohio Electric Car Co.**, Toledo, O., has increased its factory workers to 200 and has a large amount of business on hand. This concern manufactures electric automobiles and bodies for gasoline cars. About half of the work of the company is devoted to the body manufacture and the concern has 200 closed car and 100 roadster bodies in process of construction. Many of these are special taxies, roadsters and jitneys for the Willys-Overland, Inc., as well as special bodies for private owners.

**Elgin Motor Car Corp.** has appointed H. A. Oswald manager of its body division, with headquarters at Chicago. He has been in the automobile field for 16 years, being associated with the Hudson, Studebaker and Wadsworth companies until ten weeks ago, when he joined the Meridian Mfg. Co., Indianapolis, to operate the plant as general manager for the trustee in bankruptcy and to complete the contracts of 1,900 bodies for the Elgin company and 900 for the Allen Motor Co., Fostoria, O.

### Car Builders

**Stutz Motor Car Co.**, Indianapolis, will construct a new concrete and steel machine shop to cost about \$40,000.

**Pierce-Arrow Motor Car Co.**, Buffalo, will build four extensions, each about 45 x 234 ft., on Elmwood avenue.

**Ross Automobile Co.**, Detroit, it is reported, contemplates removing to an eastern city. H. D. Mackaye is general manager.

**Atterbury Motor Car Co.**, Elmwood and Hertel avenues, Buffalo, manufacturer of automobiles, is planning for the erection of an addition to its plant.

**Cruiser Motor Car Co.**, Madison, Wis., will erect the first unit of its plant on a 2½ acre site on East Johnston street and the Milwaukee road tracks. A combination touring-camping automobile will be manufactured

**Campbell Motor Car Co.**, New York, has been incorporated in Delaware with capital of \$3,000,000, to manufacture automobiles. L. H. Gunther, Joseph F. Curtin and Samuel B. Howard, New York, are the incorporators.

**Chevrolet Motor Co.**, Flint, Mich., has been granted permits for a factory to cost \$100,000 and additions to cost \$30,000. The company will move its engineering department and its purchasing office from Detroit to New York.

**Nordyke & Marmon Co.**, Indianapolis, which has a contract for manufacturing airplane motors for the United States government, will make additions to its plant to cost about \$120,000. This makes the third large addition built during the last 90 days.

**McKinnon Industries, Ltd.**, has incorporated at St. Catharine, Ont., for \$1,000,000. This company was formerly the McKinnon Chain Co., manufacturing chains and accessories, and under the new capital will manufacture automobiles, bicycles and accessories.

**Essex Motor Co.**, recently incorporated by officials and stockholders of the Hudson Motor Car Co. for the purpose of manufacturing a light car, has taken a three years' lease on the old No. 5 Studebaker plant at Detroit. It has three stories and about 60,000 sq. ft. of floor space.

**Laurel Motors Corp.**, which has taken over the Laurel Motor Car Co., has purchased a factory site in Anderson, Ind., and will erect a modern plant for the manufacture of Laurel cars and trucks, and expects to be operating the new plant about January 1. The Laurel Motor Car Co. has been manufacturing cars in Richmond, Ind., for the past two years.

**Supreme Motors Co.**, Cleveland, O., will move its headquarters to Fort Wayne, Ind., where a manufacturing plant for temporary use is to be leased. The company has a capitalization of \$1,000,000, and is to engage in the manufacture of automobile, airplane and tractor motors. Clarence F. Jamison, of Lafayette, Ind., formerly assistant general manager of the Elgin Motor Corp., Chicago, is president.

**Wisconsin Duplex Auto Co.**, Clintonville, Wis., incorporated several months ago with a capital stock of \$500,000, expects soon to make a definite decision concerning the establishment of its proposed new plant. The company has been doing experimental work in connection with the Andrews Motor Mfg. Co., 834 Muskego avenue, Milwaukee, for several months and may take over that plant. It will manufacture passenger and commercial cars with a duplex transmission system. William A. Besserdich is president and general manager.

### Parts Makers

**Ford Motor Car Co.**, Detroit, is taking bids for the erection of a new four-story brick and reinforced concrete



plant 375 x 760 ft., to be erected on the Newark Meadows, Kearny, N. J.

**Karo Carburetor Co.**, Alma, Mich., will triple the size of its plant to take care of a contract received by the Western Carburetor Co. for its entire output up to 200 carburetors per day.

**E. W. Bliss Co.**, Adams and Plymouth streets, Brooklyn, N. Y., has had plans prepared for the erection of a one-story brick addition to its works at 53d street near First avenue, to cost about \$10,000.

**Norma Co. of America**, 1790 Broadway, New York, manufacturer of ball bearings, has acquired property on the boulevard, near Marion street, Long Island City, and contemplates the erection of a new plant.

**Wire Wheel Co., of America**, Buffalo, H. F. Krause, manager, has plans in preparation for the construction of a new plant at Elmwood avenue and the New York Central Railroad, to manufacture wire wheels.

**Detroit Steel Products'** new office building is rapidly nearing completion, and will be ready for occupancy about December 1. The building is three stories, of steel reinforced concrete construction, with solid steel sashes.

**Auto Parts Mfg. Co.**, 313-317 Milwaukee street, Milwaukee, sustained an estimated loss of \$50,000 by fire, but repairs have been undertaken and operations will only be slightly interrupted. Walter H. Schwab is vice-president and general manager.

**Jackson (Mich.) Rim Corp.** has decreased its capital stock from \$10,000 to \$5,000. This company has completed a sales agreement whereby the sales department of the Perlman Rim Corp., of Jackson, has been taken over, and whereby the sales of the Perlman corporation will be conducted from Jackson instead of New York.

**Waukesha (Wis.) Motor Co.**, which has an order for 2,500 Liberty motors for the new class B military truck, 15,000 of which will be built for the government, has been obliged to increase its facilities about 50 per cent to handle the additional business. Work has been started on an addition 100 x 225 ft. to shop No. 1, and an addition 90 x 180 ft., to shop No. 2, both to be ready by December 1. From 200 to 300 additional workmen will be required. Harry L. Horning is vice-president and general manager.

### Coming Events

Los Angeles, Cal., November 12-17—Pacific Coast Show, Los Angeles Motor Car Dealers' Association.

Denver, Col., November 12-18—Automobile and Accessories Show, Automobile Trades Association of Colorado  
Springfield, Mass., December 3-9—Show, United Shows Co.

New York, N. Y., January 3-4, 1918—Quarterly meeting, Automobile Electrical Association.

New York, N. Y., January 5-12—National Automobile Show, National Automobile Chamber of Commerce and Motor and Accessory Manufacturers.

New York, N. Y., January 11-16—Meeting of National Association of Automobile Accessory Jobbers.

Washington, D. C., January 11-18—Carnival and Open House Week, Automobile Trade Association of Washington.

Montreal, Can., January 19-26—National Motor Show of Eastern Canada, Montreal Automobile Trade Association.

York, Pa., January 21-26—Automobile Show, the York Auto Dealers' Association.

Chicago, Ill., January 26-February 2—National Automobile Show, National Automobile Chamber of Commerce and Motor & Accessory Manufacturers.

St. Louis, Mo., February 11-16—Show, St. Louis Automobile Manufacturers' and Dealers' Association.

San Francisco, Cal., February 16-26—Second Annual Automobile Show, San Francisco Automobile Dealers' Association.

Boston, Mass., March 2-9—Automobile Show, Boston Automobile Dealers' Association.

### Dodge Wins Suit Against Ford

Minority stockholders of the Ford Motor Co. won the first round of their fight for increased dividends and a more important voice in the transaction of the company's business, when Circuit Judge George S. Hosmer, of Detroit, handed down on October 31 a decision for the plaintiff in a suit brought by John F. Dodge and Horace E. Dodge against the Ford Motor Co. and Henry Ford, to compel Ford to disburse about \$60,000,000 of accumulated dividends to the company's stockholders.

The Dodge brothers, who are automobile manufacturers, are also minority stockholders of the Ford Motor Co.

Ford announced some months ago that he hoped to use this money to increase his company's business. One of the features of his plan was the construction of great blast furnaces on River Rouge, near Detroit.

### "Welcome" Ambulance Design Competition

In 1915 prizes amounting to £2,000 were offered by the Welcome Bureau of Scientific Research, London, for the best improvement in motor ambulances for Red Cross work, which attracted world-wide interest. Last year four designs were selected, from which four motor vehicles were to be built and tried under working conditions. It is now announced that the four ambulances have been built and duly examined and tested by a judging sub-committee appointed for the purpose, with the result that it has been found that none are superior to the existing War Office type of ambulance; therefore no prize will be awarded. It is announced that the sub-committee's report will be published in due course. It was intended to publish all the drawings sent in, but this has not been possible, owing to a considerable proportion of the competitors refusing to allow their designs to be printed.

## WANTS

Help and situation wanted advertisements, 1 cent a word; all other advertisements in this department, 5 cents a word; initials and figures count as words. Minimum price, 30 cents for each advertisement.

**Wanted**—Copies of The Hub of May and July, 1916. Must be in good condition. Address Trade News Publishing Co., corner Elm and Duane streets, N. Y. City.

### PATENTS

**Patents**—H. W. T. Jenner, patent attorney and mechanical expert, 606 F St., Washington, D. C. Established 1883. I make a free examination and report if a patent can be had and exactly what it will cost. Send for circular.

# WHEN A LOADED TRUCK SKIDS

against the curb there's a tremendous lateral pressure on the rear wheel.

IN SHELDON SEMI-FLOATING CONSTRUCTION the wheel is mounted directly on and turns with the axle-shaft over whose entire length the lateral pressure is perfectly distributed. In the full floating type of axle, the wheel turns on the axle housing itself, presenting the very minimum of leverage against this pressure and frequently causing the axle housing to buckle with disastrous results.

FURTHERMORE—THE SHELDON BEAR-

INGS, placed both at the inner end of the axle and at the wheel, receive far less wear than those in the full-floating type where they are placed only on the wheel.

SHELDON WORM GEAR Semi-floating Rear Axles provide absolute insurance against accidents.

SHELDON AXLE AND SPRING CO.



Makers of springs and axles for heavy duty service for more than fifty years.



WILKES-BARRE

PENN'A

# SHELDON WORM DRIVE AXLES

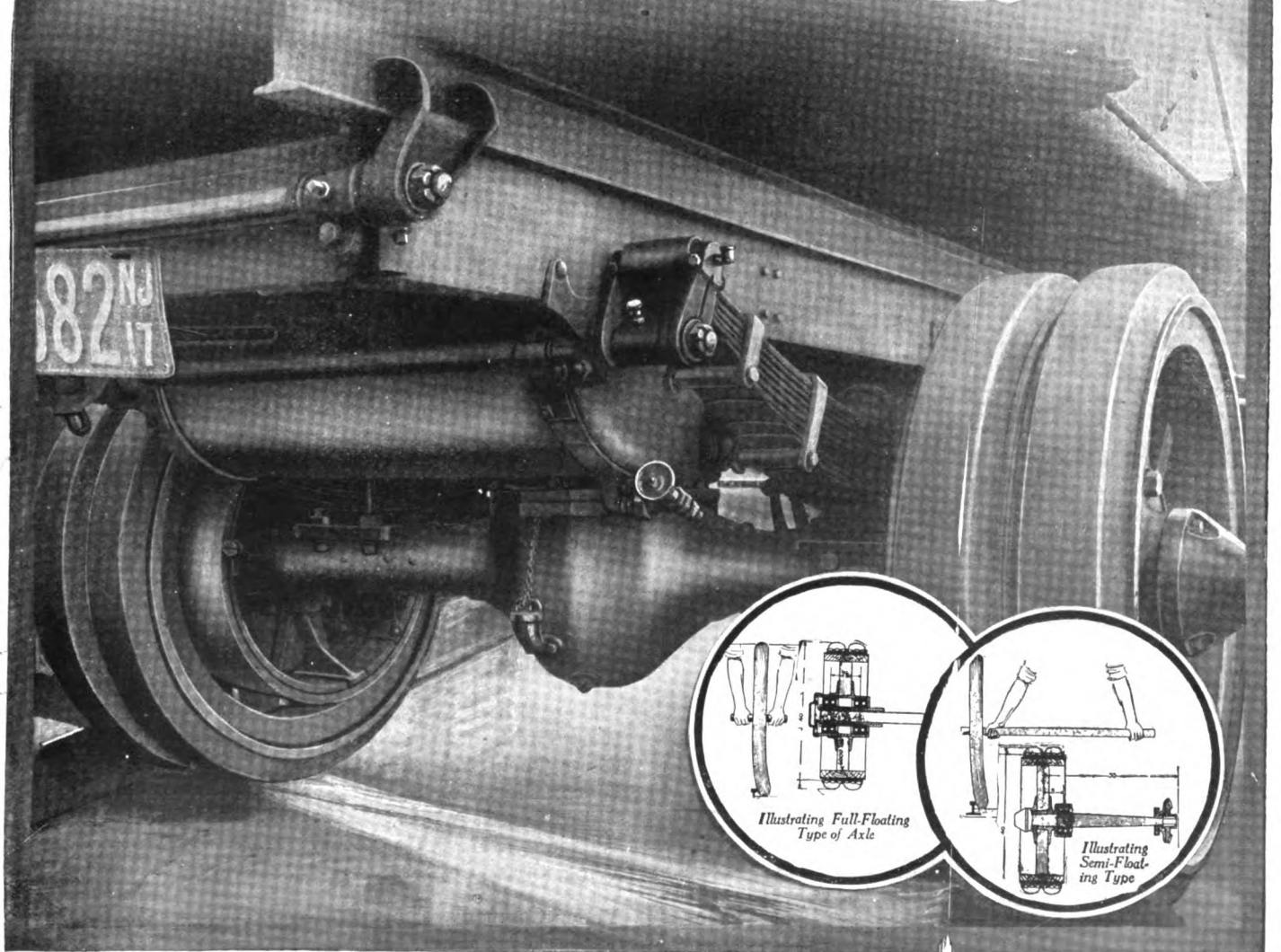

# Here's the Evidence—

that should impel you to investigate the case of the

## Premier Universal Tool and Cutter Grinder

It has massive table, micrometer adjustments, very long knee and gibs, and extra heavy head and tallstock.

Headstock is fitted with large bearing for chuck spindle and with special bronze bearings of navy specifications; spindle is tapered and bored to take wheel arbors, and bearings are 1 in. in diameter and 2 3/4 in. long; exceptionally simple and sturdy countershaft, and has self-lubricating bearings.

We'll help along your investigation—write for the details TODAY.

### Simmons Machine Co., Inc.

1001 Singer Bldg.,  
NEW YORK CITY  
981 Broadway,  
ALBANY N. Y.  
358 Ellcott Square  
BUFFALO N. Y.

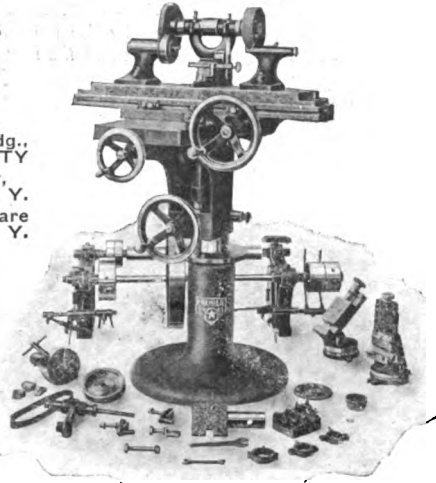

# The Best Hand Pump

## THE VICTOR



Must have brass tubes that will not rust or cut out the cups.

It must be quick in action. Motorists do not allow for tire troubles in arranging their schedules.

The cups must be of selected leather to give long service.

The design must be simple and easily understood.

This is such a pump

NOT BEST BECAUSE IT WAS FIRST  
BUT FIRST BECAUSE IT IS BEST

ASK ABOUT IT OF

**JUDD & LELAND MFG. CO.**  
CLIFTON SPRINGS, N. Y.

## Index To Advertisers

Barrell Co., Wm. L.....	42
Bliss, E. W., Co.....	3
Bradley, C. C., & Son.....	45
Bridgeport Coach Lace Co.....	41
Century-Plainfield Tire Co.....	43
Century Steel Co. of America, The.....	4
Columbus Bolt Works.....	Back cover
Cowles, C., & Co.....	44
Crane & MacMahon, Inc.....	47
Decker, J. C.....	44
Dixon, Joseph, Crucible Co.....	9
Dowler, Chas. L.....	44
Doxey, N. D.....	43
DuPont Fabrikoid Co.....	42
Eccles, Richard, Co.....	46
Empire Art Metal Co., Inc., The.....	8
G & O Mfg. Co.....	47
Gray, Peter, & Sons, Inc.....	45
Hartford Auto Parts Co.....	3
Hoopes Bro. & Darlington.....	47
Hotel Rochester.....	45
Johnston, R. F., Paint Co.....	44
Judd & Leland Mfg. Co.....	40
Keratol Co., The.....	42
Laidlaw Co., The.....	2
Mulholland Co., The.....	44
Norton Grinding Co.....	5
O'Bannon Corporation.....	Back cover
Parrott Varnish Co., The.....	2
Paulson, Thomas, & Son, Inc.....	Back cover
Pettingell Machine Co.....	7
Pittsfield Spark Coil Co.....	41
Porter, H. K.....	45
Poughkeepsie Utilities Corp.....	43
Pressed Steel Co.....	2
Quickwork Co., The.....	45
Rome-Turney Radiator Co.....	46
Russell, Burdsall & Ward Bolt & Nut Co.....	45
Sheldon Axle & Spring Co.....	First cover and 39
Simmons Machine Co., Inc.....	40
Standard Oil Cloth Co., Inc.....	6
Wayne Wheel Co.....	2
West Tire Setter Co.....	47
White-Quehl Mfg. Co.....	44
Wilcox Mfg. Co., D.....	47
Willey Co., C. A.....	46
Williams, J. H., & Co.....	10
Wing, Chas., Co.....	44
Yoder Company, The.....	4

Please mention "The Hub" when you write

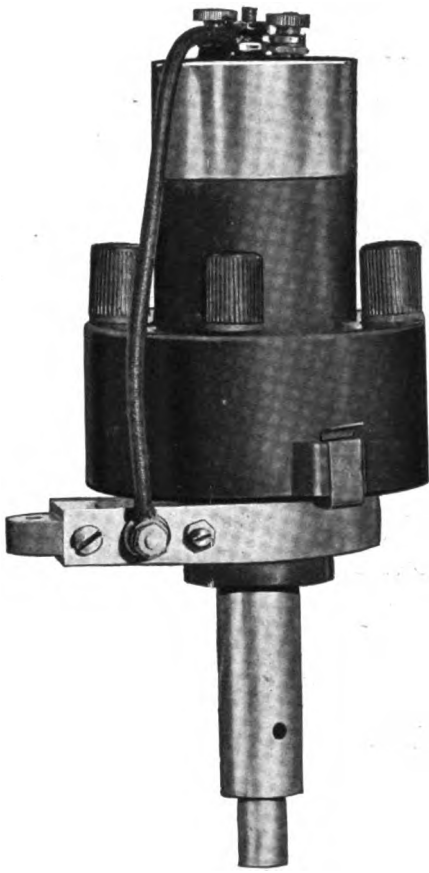

## A Perfectly Synchronized Spark at ALL Speeds

"Pittsfield" Distributor is of unit construction. It has an absolutely mechanical make and break which is positive and independent of spring action. No trips, hammers or other unreliable devices are required or used.

Its make and break is positive, giving a perfectly synchronized spark at all speeds. There is no lag in the spark—no automatic advances required.

Send for folder fully describing the "Pittsfield"

### FORD OWNERS

We have developed a special bracket for installing the "Pittsfield" Distributor on Ford Cars. Send for Folder.

Also manufacturers of "Pittsfield" Coils, Timers, Switches, "Berkshire," "Jewell," and "Micatite" Spark Plugs.



## PITTSFIELD SPARK COIL CO.

PITTSFIELD, MASS.

Leaders in their class for over three-quarters of a century

# FABRICS BRIDGEPORT FABRICS

comprise an elegant assortment of the newest weaves, shades and patterns in automobile upholstery materials

WRITE FOR SAMPLES OF OUR

LIMOUSINE LININGS, CLOTHS, CARPETS, HORSE-HAIR  
CARPETS, CURTAIN SILKS, LACES, SEAT COVER FABRICS

We also supply ROBE RAILS, SPEAKING  
TUBES and TOILET CASES to match upholstery

## BRIDGEPORT COACH LACE CO.

NEW YORK OFFICE, 1733 BROADWAY

BRIDGEPORT, CONN.

Please mention The Hub when you write

# Keritol LEATHER SKINS

For the car where leather has always been used



PRICE

*Within Reason*

QUALITY

*Maintained*

W<sup>m</sup> L. BARRELL Co. 8 THOMAS ST.  
NEW YORK

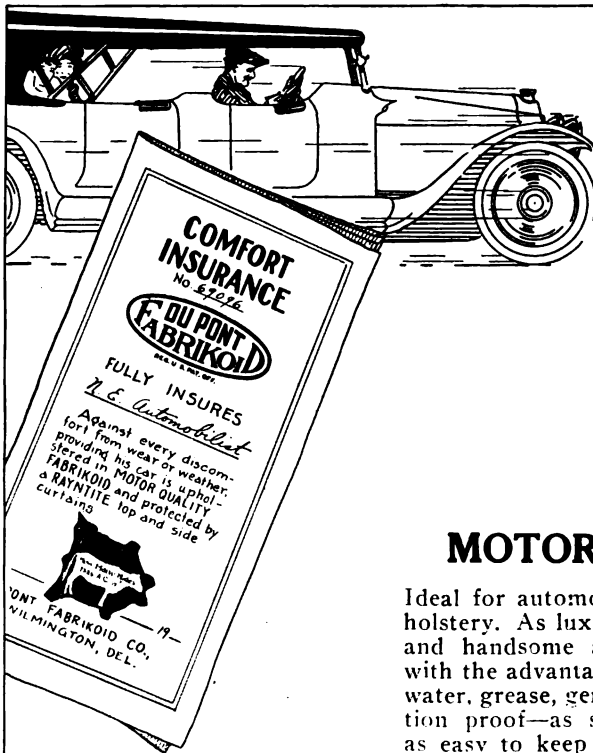

## Comfort Insurance Is Free

You pay for Fire Insurance.  
You pay for Accident Insurance.  
Comfort Insurance is a matter of policy in selecting



REG. U. S. PAT. OFF.

The Best Leather Substitute

**MOTOR QUALITY**

Ideal for automobile and carriage upholstery. As luxurious, soft, satisfying and handsome as the finest leather, with the advantage of being absolutely water, grease, germ, stain and perspiration proof—as sanitary as glass and as easy to keep clean.

**RAYNTITE**

The safest material to use for tops and side curtains on automobiles, boats and carriages. Gives absolute protection, unequalled beauty and serviceability. Guaranteed not to leak, crack or peel for one year—built to last the life of the car.

Write for Samples and Booklet

**DU PONT FABRIKOID CO. WILMINGTON, DEL.**





# ANCHOR WELDING COMPOUND

MANUFACTURED BY  
**N. D. DOXEY, ELMIRA, N. Y.**

ANCHOR WELDING COMPOUND will weld hardest steel. Will not peel apart at the weld, thus losing the heat, nor burn up when flowing on the lap. Will weld without the use of hammer. Place two flat surfaces together in the fire, smelting the Compound liberally on the parts and press pieces together firmly with tongs, and weld will be complete without a stroke of the hammer. It will not require any iron fillings to be added in welding as in some other compounds. It does the work itself. A weld made with ANCHOR COMPOUND leaves the welded parts of equal strength with solid parts of the metal. Cannot be damaged by dampness nor by heat.

Your Welding Compound gives entire satisfaction. In welding steel of high carbon, it fluxes quick and the steel appears like iron, and can be worked at a white heat. I have tried all other compounds in the market and can pronounce yours the best. It flows where you want it to flow.  
C. H. KILMER, Elmira, N. Y.

We take pleasure in stating that we have been using your Welding Compound for several years and find it a most excellent article, and can recommend it highly. Yours truly,  
THE LAFRANCE FIRE ENGINE CO.,  
W. Falck, Gen. Manager, Elmira, N. Y.

Is used by U. S. Navy and C. & N. W. Ry. Co. and many others.

IN USING do not throw the Compound from the surface to be welded, but cup the scarf, and in light work turn the piece, when ready for welding, so that the Compound will flow evenly over the surface to be welded, which it will readily do, flowing like oil. In heavier work, add compound to surface to be welded, as heat nears welding point, so that surface to be welded is covered with fused compound.



## DO YOU HEAR the UTILITY KID signaling you to go ahead and get UTILITY VARNISH RENOVATOR

YOU ARE THE JUDGE AND JURY  
It costs you a postage stamp to get enough  
**Utility Varnish Renovator**

to prove whether it's what you want to PRESERVE the fine finish of your automobile and keep it clean and bright with perfect SAFETY. Compare it to other methods you have tried, especially for WINTER cleaning.

Write today for your sample  
Our guarantee is your protection

List Prices:

4 ounce bottles, 25c	Quart cans, \$1.00
12 ounce bottles, 50c	Gallon cans, 3.00
Sprayer, 25c	

**Poughkeepsie Utilities Corporation,**  
44 WINNIKEE AVENUE, POUGHKEEPSIE, N. Y.



# Superbar Tires

"Service Tires"

Made of high grade fabric and best grades of pure rubber to meet the demand of those who seek a good Standard Quality Tire giving maximum amount of service for money invested.

Built by HAND throughout.

SUPERBAR Tires are the result of many years of scientific experimenting and combine quality of material, skill in workmanship and a maximum of road resistance.

Adjusted on 3,500-mile basis. Ford sizes, 4,500-mile basis.

Splendid agency opportunities are available; particulars on request.

**Century-Plainfield Tire Co.**  
Plainfield, N. J.

Century-Plainfield Tire Company, a subsidiary of the Rubber Metals Corporation, exclusive manufacturers of the Rimco Rubber Products by the Elchemco process

Please mention The Hub when you write



## BUSY BUYERS BRIEFS

### JOHNSTON'S KRAKNO

Color Card Free  
\$3.50 per gallon

The R. F. Johnston Paint Co.  
Cincinnati, Ohio

### THE CHARLES WING CO.

Established 1848

Manufacturers and Wholesale Dealers in  
**AUTOMOBILE AND CARRIAGE  
HARDWARE AND TRIMMINGS**  
AMESBURY, MASS., U. S. A.

### Why Not Have the Best?

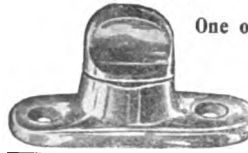

One of a Large Variety

G. Cowles & Co.

NEW HAVEN,  
CONN.

### J. C. DECKER

MONTGOMERY, PA.

Manufacturer of

### Carriage, Skate and Pad Straps

Side Loops, Bridle Fronts, Tail Ties, etc.

### CHARLES L. DOWLER

CARRIAGE AND WAGON HARDWARE

108 North Third St., Philadelphia, Pa.

### CUSHION MANUFACTURER

Pure Stearic Acid Candles. Wheel Stock. Snow  
Flake Axle Grease.

### MULHOLLAND BUGGY SPRING

Reduces weight of springs one-half.  
Made in one size only but will fit bodies  
of all widths.

Write for further particulars and prices.  
THE MULHOLLAND CO. DUNKIRK, N. Y.

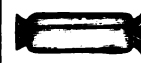

LINED



UNLINED

### White's Brazing Sleeves

For applying Rubber Tires  
Send for Samples.

WHITE-QUEHL MFG. CO.

431 E. Pearl St.  
CINCINNATI, OHIO

## CLASSIFIED INDEX

For Addresses See Alphabetical Index  
and Advertising Pages

### AUTOMOBILES

American Motors Corp., Plain-  
field, N. J.

### AUTO FABRICS

Barrell, Wm. L., Co., New York  
Keratol Co., The, Newark, N. J.  
Laidlaw Co., Inc., The, New  
York.  
Standard Oil Cloth Co., New  
York City.

### AUTO PARTS

Hartford Auto Parts Co., Hart-  
ford, Conn.

### AXLES (Including Ball and Roller Bearing)

Sheldon Axle & Spring Co.,  
Wilkes-Barre, Pa.

### BOLTS AND NUTS

Columbus (O.) Bolt Works Co.  
Russell, Burdsall & Ward Bolt  
& Nut Co., Port Chester, N.Y.

### BOLT CLIPPERS

Porter, H. K., Everett, Mass.

### BRAZING SLEEVES

White-Quehl Mfg. Co. Cincin-  
nati, O.

### BRONZE BEARINGS

Lumen Bearing Co., Buffalo.

### DIES

Bliss Co., E. W., Brooklyn, N.Y.  
(Sheet Metal Working).

### FORGINGS

Eccles, Richard, Auburn, N. Y.  
(Carriage, Drop).  
Williams, J. H., & Co. Brook-  
lyn, N.Y. (Automobile, Drop)

### FIFTH WHEELS

Wilcox Mfg. Co., D., Mechanics-  
burg, Pa.

### HARDWARE (Carriage, Wagon and Automobile)

Columbus (O.) Bolt Works Co.  
Dowler, Chas. L., Philadelphia.  
Eccles Co., Richard, Auburn,  
N. Y.  
Wilcox Mfg. Co., D., Mechan-  
icsburg, Pa.  
Wing Co., Chas., Amesbury,  
Mass.  
Cowles, C., & Co., New Haven,  
Conn.

### LEATHER SUBSTITUTES

Barrell Co., Wm. L., New York.  
Keratol Co., The, Newark, N. J.  
Standard Oil Cloth Co., New  
York.  
DuPont Fabrikold Co., Wil-  
mington, Del.

### LUBRICANTS

Dixon, Jos., Crucible Co., Jer-  
sey City, N. J.

### MACHINERY AND TOOLS

Bliss Co., E. W., Brooklyn, N.Y.  
Norton Grinding Co., Worces-  
ter, Mass.  
Pettingell Machine Co., Ames-  
bury, Mass.  
Simmons Machine Co., Inc.,  
Albany, N. Y.; Singer Bldg.,  
New York City.  
Smith, H. Collier Detroit, Mich.  
West Tire Setter Co., Roches-  
ter, N. Y.  
Williams, J. H., & Co., Brook-  
lyn, N. Y.  
White-Quehl Mfg. Co., Cincin-  
nati, O.  
Yoder Co., The, Cleveland, O.

### MACHINERY (Metal Working)

Bliss Co., E. W., Brooklyn, N.Y.  
Pettingell Machine Co., Ames-  
bury, Mass.  
Quickwork Company, Detroit,  
Mich.  
Yoder Co., The, Cleveland, O.

### MAGNETOS

Berkshire Magneto Co., Pitts-  
field, Mass.

### METAL STAMPINGS AND NOVELTIES

Gray, Peter, & Sons, Inc., Cam-  
bridge, Mass.  
Pressed Steel Co. of New York,  
New York City.

### MOTORS

Brennan Motor Mfg. Co. Syra-  
cuse, N. Y.

### PATENTS

Jenner, H. W. T., Washington,  
D. C.

### PAINTS AND COLORS

Johnston Paint Co., R. F., Cin-  
cinnati, O.  
Pierce Co., F. O., New York.  
Wiley Co., C. A., Hunter's  
Point, N. Y.

### PRESSES

Bliss Co., E. W., Brooklyn, N.Y.  
(Drop, Power).

### RADIATORS

G. & O. Mfg. Co., New Haven,  
Conn.  
Rome-Turney Co., Rome, N. Y.

### SCHOOL FOR DRAUGHTS- MEN

Mechanics' Institute, New York

### SHAFT COUPLINGS

Bradley & Son, C. C., Syracuse,  
N. Y.  
Eccles Co., Richard, Auburn,  
N. Y.

### SPARK COILS

Pittsfield Spark Coil Co., Pitts-  
field, Mass.

### SPRINGS

Mulholland Co., Dunkirk, N. Y.  
Sheldon Axle & Spring Co.,  
Wilkes-Barre, Pa.

### STEEL

Century Steel Co. of America,  
Poughkeepsie, N. Y.; Sales  
office, 120 Broadway, N. Y.

### TIRES

Century-Plainfield Tire Co.,  
Plainfield, N. J.  
TIRE PUMPS  
Judd & Leland Mfg. Co., Clifton  
Springs, N. Y.

### TOOLS

Williams, J. H., & Co. Brook-  
lyn, N. Y.

### TRIMMING MATERIAL

Bridgeport (Conn.) Coach Lace  
Co.  
Decker, J. C., Montgomery, Pa.  
Wing Co., Chas., Amesbury,  
Mass.

### UNIVERSAL JOINTS

Hartford (Conn.) Auto Parts  
Co.

### VARNISH AND JAPAN

Parrott Varnish Co., Bridgeport,  
Conn.  
Pierce Co., F. O., New York.  
Wiley Co., C. A., Hunter's  
Point, N. Y.

### VARNISH RENOVATOR

Poughkeepsie (N. Y.) Utilities  
Corp.

### WHEELS

Crane & MacMahon, Inc., New  
York City.  
Hoopes Bros. & Darlington,  
Inc., West Chester, Pa.  
Wayne Wheel Co., Newark, N.J.

### WOOD BENDINGS, WHEEL STOCK, ETC.

Crane & MacMahon, Inc., New  
York City.

Please mention "The Hub" when you write



# RADIATOR INSURANCE

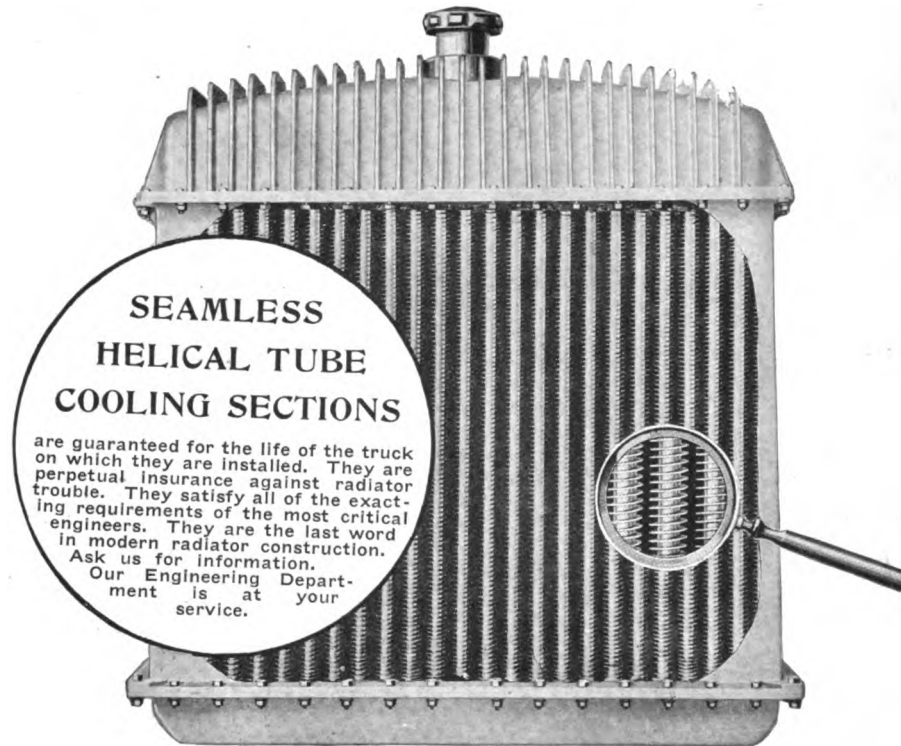

ROME-TURNEY RADIATOR CO., Sole Manufacturers, ROME, N. Y.

## WILLEY'S COLORS

The Recognized Standard



**C. A. WILLEY CO.**  
COLOR GRINDERS

and Manufacturers of Specialties in

**CARRIAGE, AUTOMOBILE and CAR**

**PAINTS**

**COLORS, VARNISHES, ETC.**

**HUNTER'S POINT, NEW YORK CITY**

## Automobile, Carriage, Wagon and Special FORGINGS

of Guaranteed Quality

When you are in the market, send us your blue-prints for quotations.

Ask for catalog showing part of our large line of Automobile and Special Forgings, also catalog listing our full line of Carriage and Wagon Hardware.

**Richard Eccles Co.**  
AUBURN, NEW YORK

ESTABLISHED IN 1880

Please mention "The Hub" when you write



# HOOPES BRO. & DARLINGTON

(INCORPORATED)

## WEST CHESTER, PA.

WE ARE MAKING

# AUTOMOBILE WHEELS

Forty Years' Experience as WHEEL MAKERS is guarantee we can make good ones.  
Will not make any other kind. Try them.



ENGINE COOLING

## RADIATORS

FOR PLEASURE CAR AND HEAVY DUTY SERVICE

G & O MFG. CO.

New Haven, Conn.

## WILCOX

FINE  
FINISHED  
FORGED

### CARRIAGE HARDWARE AND GEAR IRONS

Write for Prices and Catalog

### The D. Wilcox Mfg. Co.

MECHANICSBURG, PA.

## The WEST Hydraulic Tire Setter

### WILL CUT DOWN EXPENSE

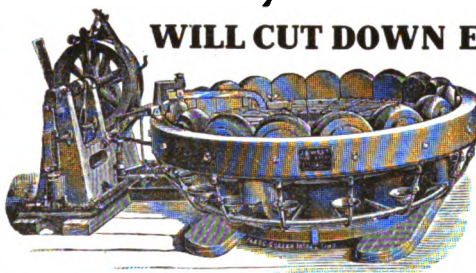

Tires set cold in one minute. This machine saves time—does the work better and quicker, does a way with burned streaks. Only necessary to measure one wheel in a lot. Does not char the rim, and

thus make the tire loosen prematurely. Saves resandpapering of wheels. This machine is now increasing the profits of many manufacturers. Send for catalog and read about it.

**WEST TIRE SETTER CO.,**

**ROCHESTER, NEW YORK**

## AUTOTRUCK

### Hickory Nut and

BEST QUALITY STOCK  
TOUGH AND HEAVY  
BONE DRY

MANUFACTURED BY  
CAPABLE MECHANICS  
AND MOST  
IMPROVED MACHINERY

WHEELS WHICH ADD TO  
THE LIFE OF YOUR TRUCK

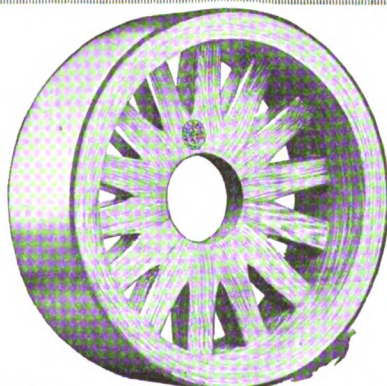

## WHEELS

### Acorn Brands

HORSE-DRAWN  
VEHICLE WHEELS  
ALL STYLES

TRAILER WHEELS:  
SARVEN AND  
ARTILLERY TYPES

HIGH STANDARD OF  
QUALITY AND  
WORKMANSHIP  
MAINTAINED

ST. MARYS, OHIO

**CRANE & MacMAHON, Inc.**

8 BRIDGE ST., N. Y. CITY

Please mention "The Hub" when you write

**O'BANNON**



**COATED FABRICS**

*Variety of Qualities*  
WRITE FOR SAMPLES  
**O'BANNON CORPORATION**  
200 FIFTH AVE. NEW YORK

THE IDEAL TOP MATERIAL

THE SUPERIOR LEATHER SUBSTITUTE





## Skewed Shaft Couplings

**Regular or Oval Patterns  
For High Arched Axles**

Furnished in rights and lefts for any height of arch.  
Oval Axle Clips  $\frac{5}{8}$  or  $\frac{3}{4}$  width to match Oval Couplings. Bolts, Clips, Couplings, Carriage Hardware and Special Forgings

Catalogue "H" and Prices on Application

**COLUMBUS BOLT WORKS COMPANY**  
COLUMBUS, OHIO



The machinery of the country is running at top speed to supply war needs. Machines are supplementing man power to make up for labor

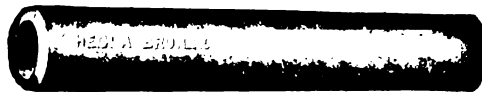

shortage. The wheels MUST be kept turning—automobiles, gas, oil and steam engines, railway trucks, generators and everything that runs in bearings.

# "HECLA" ANTI-FRICTION BRONZE

will keep them moving, smoothly and efficiently. This alloy is the result of 32 years' experience and research. "HECLA" WILL NOT CUT the journal or pin under the severest service conditions. Will not pound out or break, MACHINES CHEAPLY and has NO SUPERIOR regardless of price. Let us send the little "Hecla" booklet. We also make Castings—finished or rough, in Brass, Bronze, Aluminum, Hydraulic Metals, Copper, Acid Metal.

**BRASS FOUNDERS ENGINEERS** **THOMAS PAULSON & SON, Inc.** 97 SECOND AVENUE BROOKLYN, N. Y.



# The Hub

First Journal of the Vehicle Industry

Vol. LIX

NEW YORK, DECEMBER, 1917

No. 9

**Witness  
a  
Drop-Forge  
Shop  
in action**

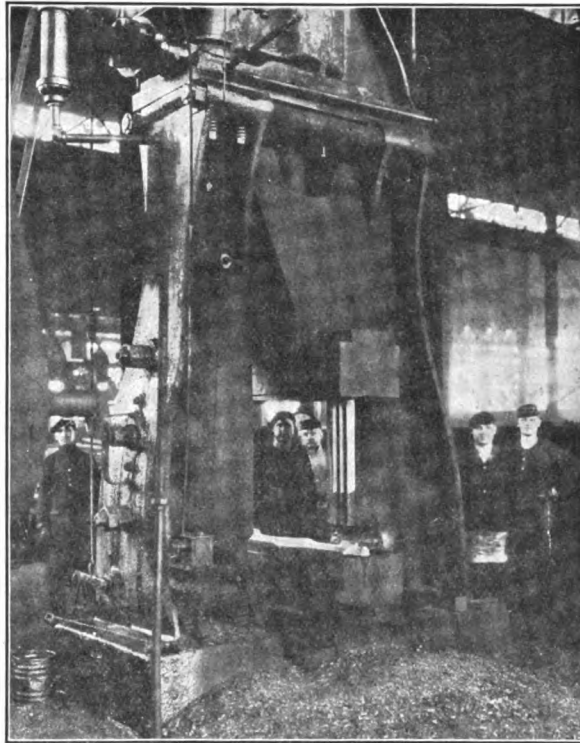

12,000 LB. DROP HAMMER

WHAT DROP-FORGINGS ENDURE THERE EXPLAINS WHY  
"SUPERIOR DROP-FORGINGS" ENDURE EVERYWHERE

**And  
you acquire  
a new idea  
of  
endurance**

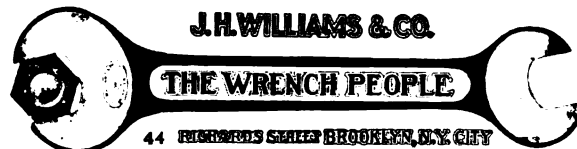
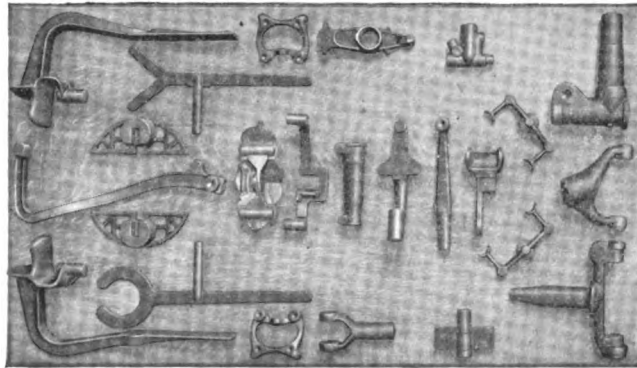



# MERITAS

---

## LEATHER CLOTH

### **Weights, Colors and Finishes For Every Leather Substitute Use**

Meritas Leather Cloth is the leading leather substitute. The range of styles, weights, grains, colors and finishes is the largest in this field.

The quality of Meritas Leather Cloth is always dependable. Every piece of it is backed up by the reputation of the largest manufacturers in this industry.

The trademark, Meritas Leather Cloth, is stamped on the back of each piece so you can make sure of the quality you buy.

Long experience and five modernly equipped plants enable us to produce Meritas Leather Cloth in quantity and quality to meet every requirement of the carriage and automobile trades.

**Write for Samples**

**The Standard Oil Cloth Company**

INCORPORATED

320 Broadway

New York



# There is a size that will successfully meet your exact requirements

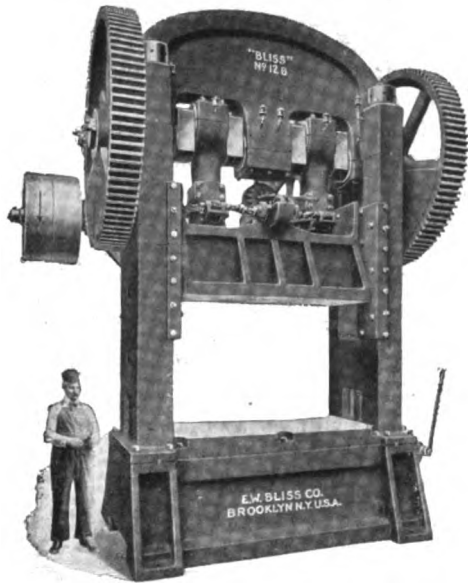

Presses with correct proportions for use in the manufacture of large sheet iron and steel goods. The large diameter shafts and well-gibbed sides allow quantity production that's profitable.

## Bliss Double-Crank Presses

Adapted for the economical production of vapor stoves, wrought iron ranges, agricultural implements, automobile stampings, steel car parts, ceilings, sidings, metal doors, window frames and sashes, metal furniture and similar goods.

Built in over 150 sizes, there is one adapted to your special requirements. Write today for descriptive matter.

*Talk to us about presses for any and every requirement*

## E. W. BLISS CO

38 Adams St., Brooklyn, N. Y.

Chicago Office: Peoples Gas Building.

Detroit Office: Dime Bank Building.

Cleveland Office: Union Bank Building.

Offices in Europe: 100 Boulevard Victor-Hugo, St. Ouen, Paris;  
Pocock St., Blackfriars Road, London, S.E.



# Hartford Universal Joints

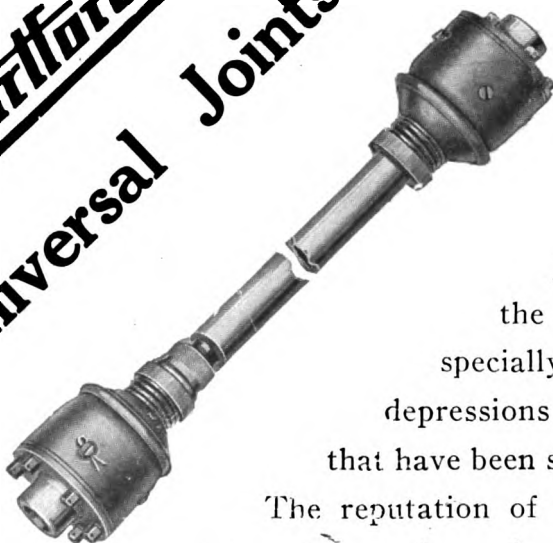

WE are able to offer manufacturers universal joints manufactured by specialists in one of the largest plants in the world.

The wearing surfaces of HARTFORD UNIVERSAL

JOINTS are hardened and ground, the grinding being accomplished by a specially devised machine whose use eliminates depressions or elevations so common in steel parts that have been simply reamed.

The reputation of your car demands the best universal joints that can be made, and we have them.

# The Hartford Automobile Parts Co.

Established 1906

Hartford, Conn.

Please mention "The Hub" when you write.

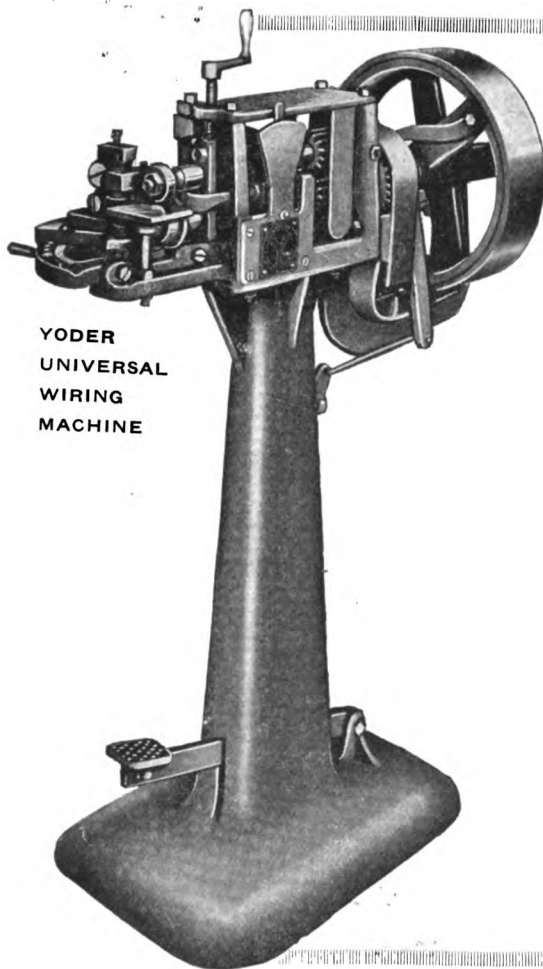

YODER  
UNIVERSAL  
WIRING  
MACHINE

## Yoder Sheet Metal Machinery

Our line of Auto Sheet Metal Working Machinery is efficient in every detail.

Every machine is constructed with the objective of producing perfect results at a minimum cost of material and labor.

The Yoder Company guarantees its machinery to produce results satisfactory to the purchaser.

We are glad to consider your Sheet Metal Machinery needs, as well as your requirements for special machines.

If you are thinking of making your own sheet metal parts or producing sheet metal products for the trade, get in touch with us at once. We can save you money and furnish a most satisfactory and complete equipment.

Catalog and prices furnished on request

**The Yoder Company**  
Engineers Building  
CLEVELAND - - OHIO

# CENTURY

"C. T. V. No. 5"

## Tungsten Valve Steel

Regular Analysis or to Special Analysis for  
TOUGHNESS RIGIDITY HIGH HEAT RESISTANCE

### THE CENTURY STEEL CO. OF AMERICA

Manufacturers of High-Grade Crucible Steels

General Office and Works:

POUGHKEEPSIE, N. Y.

CHICAGO SALES OFFICE:

E. P. Bartlett & Co., 15 N. Jefferson Street

PHILADELPHIA SALES OFFICE:

Century Steel Co. of America, Real Estate Trust Bldg.

CLEVELAND SALES OFFICE:

J. E. Rawson, Rose Building

NEW YORK SALES OFFICE:

Century Steel Co. of America, 120 Broadway

Please mention The Hub when you write



# Norton Finish

**N**OWHERE is fine finish more essential than in piston work for internal combustion engines. The slightest deviation from a mirror surface may cause damage through cylinder scoring. The accuracy of such work must by the same token be positive.

Norton Grinding Machines are successfully meeting in scores of Motor plants throughout the country these demands of accuracy and finish in cylindrical grinding. But they are not limited in their range to fine, delicate work: they are also meeting the problem practically and economically of metal reduction in rough grinding.

Let us advise you on the work that hasn't been quite satisfying you.

## Norton Grinding Company

Worcester, Mass.

Chicago Store:  
11 N. Jefferson St.





---

# AMERICAN

**The Car of  
1918. (See it at  
the Automobile  
Shows)**

O.K.  
Chevrolet

---

AMERICAN MOTORS CORPORATION  
LOUIS CHEVROLET, VICE-PRESIDENT AND CHIEF ENGINEER  
FACTORY AND SALES OFFICES: PLAINFIELD, NEW JERSEY

Please mention "The Hub" when you write.



# **ANNOUNCEMENT**

In addition to our regular line of metal and wood auto body and aeroplane machinery, we have opened a department for the manufacture of **AUTOMOBILE HARDWARE** and are now in a position to supply many parts:

**Windshields**

**Pedestal Bases**

**Rocker Plates**

**Hinges**

**Stock Clamps** (for use in wood mill)

**Special Parts**

**Aeroplane Hardware**

**Special Tools** (for body machinery)

We would suggest that manufacturers place their orders for hardware parts soon, as our supply is to be limited. If in need of any special parts **WRITE US** and we shall be glad to give you all information possible. Automatic Machinery enables us to turn out parts rapidly and at a low figure.

**Get our prices before placing order**

**Pettingell Machine Co.**

**Amesbury, Mass.**



# EMPIRE STEEL TUBING

far excels ordinary tubing. It is especially prepared for the manufacture of *Automobiles, Auto Trucks, Aeroplanes, Motorcycles, Bicycles, Tricycles, Velocipedes, Beds, Baby Carriages, Pumps, etc.*

Made round or square, with welded, lock or open seams.

If you wish to manufacture products of the highest character insist upon *Empire Steel Tubing.*

**EMPIRE**  
**ART METAL CO**  
INCORPORATED  
**COLLEGE POINT, N.Y.**

## If You Could See Your Bearings Under a Microscope

You would see, no matter how carefully they may be finished, they are pitted with minute holes. There's where *Friction* produces wear and tear and puts a crimp in your power.

Oil and grease put a film between the rubbing surfaces, but at best they can only *retard Friction*, not overcome it. You are burning more gas to offset unnecessary *Friction*. But, until you have better lubrication, *Friction* is shortening the days of your car's usefulness. The only way to *eliminate Friction* is to use

### **DIXON'S** GRAPHITE Automobile **LUBRICANTS**

prepared from the highest quality of flake graphite. They smooth over the rough places, put an end to wear and tear.

Your bearings run cool and quietly, regardless of speed or load. You get more miles to a gallon of "gas"—more power. As repair bills are lessened, your car's life is lengthened. There's a Dixon Lubricant for every part of your car.



Write Dept. 123-G for the Dixon Lubricating Chart



## Joseph Dixon Crucible Company

Jersey City

Established 1827

New Jersey

# Speaking About Differentials—

CONSIDER, please, the terrific strains a differential in a big loaded truck must stand; the rough roads, the sharp, quick corners, the sudden stops and starts, the uneven pulls when one wheel slips and the other grips.

Still, we have yet to hear of a single differential in a SHELDON Axle that has ever worn out.

—or of one that ever had to be replaced because of faulty workmanship or material.

And the SHELDON wear proof differential is but one of many big features to be found solely in SHELDON Axles.

Sheldon Axle & Spring Co.  
Wilkes-Barre Penna.

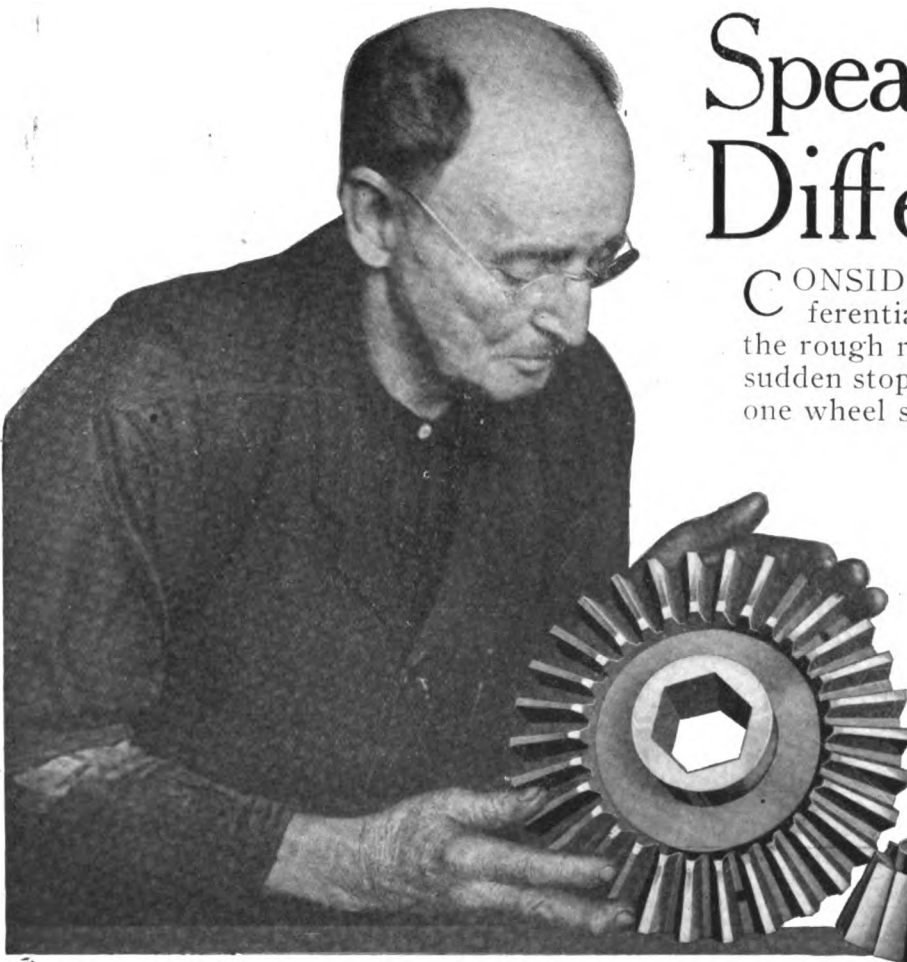

The construction of the bevel gears, with an extended hub inserted into a bearing ring in the spider, gives the gear a steady, substantial bearing support **on both sides** and unites the whole Differential into an inflexible unit, insuring absolute alignment and eradicating all possibility of faulty performance.

Notice, too, Sheldon's design of the gear teeth. Instead of being slightly concave, as is the usual method of manufacture, the teeth are broad and thick at their base, thus giving greatest strength of metal where it is most needed to lessen wear and protect against gear "stripping" under abnormal strain.

Oil holes and grooves provide lubrication and larger contact surfaces between the bevel gears, and the pinions allow a better distribution of load, which prevents the oil from being squeezed out from between the teeth by undue pressure.

## SHELDON WORM GEAR AXLES

Notice, too, how SHELDON further combines greater strength with efficiency in the hexagonal broaching of the differential gear to receive the axle shaft. A square insertion would allow for wear. A splined insertion would weaken the metal. SHELDON design avoids both weaknesses.

Please mention "The Hub" when you write

# The Hub

Vol. LIX

NEW YORK, DECEMBER, 1917

No. 9

Published Monthly by

## THE TRADE NEWS PUBLISHING CO. OF N. Y.

PAUL MORSE RICHARDS, *President* G. A. TANNER, *Secretary and Treasurer*

EDISON BUILDING, COR. ELM AND DUANE STS., NEW YORK

THE HUB, a monthly authoritative journal on all subjects pertaining to the vehicle industry from its engineering and construction viewpoints. It publishes information of live interest to manufacturers of motor vehicles, trailers, carriages, wagons, the accessory trades, repair shops and garages.

Subscription price for the United States, Mexico, Cuba, Porto Rico, Guam, the Philippines, and the Hawaiian Islands, \$2.00; Canada, \$2.50; payable strictly in advance. Single copies, 25 cents. Remittances at risk of subscriber, unless by registered letter, or by draft, check, express or post-office order, payable to the order of THE TRADE NEWS PUBLISHING CO.

For advertising rates apply to the publishers. Advertisements must be acceptable to publishers. Copy for new advertisements must be received by the 25th of the preceding month. All communications must be accompanied by the full name and address of writer.

Entered in the New York Post Office as Second-class Matter

## Government's Stupendous Task

There is general appreciation of the fact that it is a stupendous task to raise twenty billion dollars in a year, but the public is slow in grasping the fact that it is also a stupendous task for the government to get twenty billion dollars' worth of work done in a year. The industrial resources of this country are very great, but the ordinary supply of labor was fully employed when this country entered the war.

This country can carry on the war indefinitely and put steadily increasing weight and efficiency into it if its operations are well ordered. But it cannot throw millions of men upon war work except as it takes them off of other work, and it cannot pay billions into the Treasury except as it curtails expenditures in other directions. It is just as important to plan upon one side of the problem as the other, and nothing but confusion will result from going ahead without a careful co-ordination of efforts. In short, to reorganize the industries of the country on a war basis the government must take the lead and give order and system to the rearrangement.

The full powers of the country cannot be exerted immediately, for it is only by degrees that the people can be brought to understand the part which as individuals they are required to play. They have to be educated to the war task. They have to learn that a great war, calling upon this country for 18 or 20 billions a year, cannot be carried on by the government alone, in a purely official capacity, without interfering with the business or pleasures of the people.

It is natural for the people to go along in their accus-

tomed ways, trying to do business as usual and live as usual, until they are shown what the government wants of them. It is for the government to co-ordinate the productive powers of the country and direct them into the channels where they will count for most.

## Interstate Motor Traffic

Two current instances of the new use of motor vehicles for long distance freight and mail transportation have an interesting bearing on future development along this line. From Detroit a train of 30 army motor trucks will haul war supplies to the seaboard for shipment to France; and in Philadelphia steps are being taken to establish a motor mail service to New York which will include the delivery of produce from suburban farming regions.

Shall we some day have caravans of motor trucks traversing the country, each carrying its load of freight? Possibly in this evolution lies some relief of railroad congestion; managers have testified to the effect of motor travel on passenger transportation, and freight traffic may be similarly affected as motor carriers increase in number and in efficiency for this work. It is conceivable that jitney freight transportation may eventually compete with rail transportation for short hauls through superior quickness of delivery.

Given that prospect, there are to be considered the resultant effects of highway congestion, of wear and tear on roadbed and of numerous other new conditions. There will be problems of franchise taxes and governmental regulation. It will obviously not be an unmixed blessing to fill rural roads with ponderous freight cars. They will impose new impediments on city traffic. But apparently it is a condition for which the country may soon have to prepare, in view of the great strain already put on its regular transportation facilities and the urgent need of augmenting them.

## Germany's Trade After the War

Notwithstanding the confidence that the German people may have in their military strength, there is much evidence that the commercial classes are gravely apprehensive that the antagonisms arising from the war will seriously affect the trade relations of the country when peace is restored. The longer the war is continued and the more belligerents are drawn actively into it, the more serious these after-effects will be. The interest of Germany in the recovery of its foreign trade is shown by the recent action of the Reichstag in passing an immense grant of aid to the German steamship companies to enable them to buy and build



ships rapidly as soon as peace is established. Ships alone cannot command foreign trade. Every year that the war continues will make it more difficult for Germany to recover the trade position she formerly held. She cannot recover it by force. Her shipping grant will be useless unless she intends to make peace upon terms that will convince the world that her military ambitions are abandoned, and that the spread of German influence is not a menace to all other nations.

### Arrangement of Seats and Upholstery an Important Factor

At the coming show one of the most noticeable features of the cars which will be on exhibit will be the fact that the interiors have been more carefully worked out than ever before. One of the reasons for this is that due to the advanced cost of materials the smaller car is coming into marked favor, and through ingenious designing it has been made possible to accommodate just as roomy a body on a shorter wheelbase as was possible a few years back on the longest wheelbases.

It used to be that when a truly luxurious car was wanted the designer was compelled to start with a very long wheelbase in order to accommodate all the body comfort features that he desired to incorporate in his car. This condition has changed, and due to the fact that engines are shorter and do not eat up as much of the wheelbase, and also due to the fact that springs are longer, allowing a greater overhang back of the rear axle, a great amount of room can be incorporated in the body for a given wheelbase which formerly was impossible.

This matter of interior comfort is something which has been studied on the closed car as well as on the open. It has made itself felt in the fittings of the enclosed car particularly. One of the most troublesome points in regard to closed car practice with the earlier designs was the method of stowing the extra seats in the sedan type of body. The popularity of the sedan has compelled a very careful study of its interior arrangement, and the result has been some remarkably clean designs. This matter of taking care of the extra seats has also been an essential matter on the limousine as well as the sedan. It does not make so much difference if the fact that the car has two extra seats is not concealed, but it does make a tremendous difference if these seats are in the way when they are not wanted. In this year's cars it will be particularly noticeable that the two extra seats are certainly out of the way when they are not required.

#### Driver Must Have a Clear Vision

The demand for sociability in seating in the closed car types has been effected by the fact that the driver must have a clear vision. The circular arrangement of seats in the coupe works out very well if great care is used in the placing of the seats so that the viewpoint of the driver is not obstructed either in front or behind, or to the left or right. It is necessary in crossing thoroughfares, to be able to clearly see if vehicles are coming in either direction, and the reduction in the amount of space taken up by pillars is carefully watched. Even if the thickness of pillars for the support of the top is being cut down, it is naturally certain that the placing of the extra seats about the body is also going to be closely scanned in order to see that the driver does not have to crane his or her neck to see if it is safe to go ahead on a crossing.

From appearance standpoint the interior of the closed car is receiving very particular attention, and is undergoing somewhat of a change this year. The all-lined body is being very much favored, and in the finer jobs which closely follow custom-built practice, the roof lining does not match the lining of the interior of the car, but blends with it in mild contrast. On the open cars it has been found very serviceable to line the entire body with leather and not to leave any metal parts exposed. The latter are always sure to be scratched after they are in use for a time and give the car an unsightly appearance.

No matter how much out of the way a part of the interior of the car may seem, it is nevertheless a fact that it is sure to become scratched if it is painted and varnished metal.

The sedan type of body requires the divided front seats, because it generally is equipped with only a rear door. The single door type has become popular because it is fine in appearance, and, furthermore, because it has only one door it has a minimum chance to rattle. The two most difficult parts of a closed body to keep free of rattles are the doors and the upper parts of the windows. These are subject to the distortions due to the stresses imparted by irregularities in the road, and are always certain to prove troublesome unless the very finest construction is employed. Even in the most expensive bodies door rattles are not uncommon.

#### Angle of Seat Backs Highly Important

The interior of the touring car, says Merle Shepard, in the *New York American*, is of importance in spite of the fact that it appears so nearly standardized and a matter of development. The angle of the seat backs is a highly important part, and in a great many instances influences the sale of cars. Prospective buyers of cars will often drop into a salesroom and sit in the car to make up their minds whether or not they like it. This is a wise way to go about picking out a car, because with a given mechanical specification and assuming for the moment that the two cars are equal in all other respects, it is certainly a matter of supreme importance to the buyer to know that he is going to be comfortable in using his car.

The extra seats of the seven-passenger car are now painted and upholstered more completely than they were when seven-passenger cars were first put on the market, and a great many seven-passenger cars have been sold on the strength of this during the past year. As a matter of fact the people occupying the two extra seats may have to ride just as far as those occupying the rear seats, and, this being true, the comfort part of the extra seats cannot be overdone. Probably where most of these extra seats fail is that the backs are too upright and do not give the sense of luxury which is imparted by having the seat tilted slightly backward to allow the occupant to be more at ease.

The divided front seat touring car must be exceptionally well made to remain free of rattles and to remain free of binding doors, or doors which are just the opposite and refuse to stay closed. The touring car with a complete front seat is provided with a transverse stiffening member which certainly holds the body against racking and collapsing stresses. On the other hand, the divided front seats cut this cross member, thereby greatly weakening the structural advantages of the touring car. To com-

pensate for this it has to be extremely well made or else door troubles are sure to develop.

The fittings which are used on the interior of cars, such as the robe rails, foot rails, door pockets, etc., are much greater contributors to the comfort of motorists than their simplicity would suggest. On the touring car the well equipped door pocket is something which comes in very handy on troubles where the car is out on the road all day. These pockets can contain lunch kits, small tool boxes, tire gauges and all the little comforts which come in handy to those who spend a considerable time on the road.

Touring for pleasure will probably be cut down to some extent in deference to the wishes of the Administration to conserve fuel, and trips when taken will be shorter, but nevertheless there will be a great amount of road travel by civilians as well as by army officers, and the well designed interior, with its complete equipment, is going to be one of the most prized of comfort features.

### First Auto in New York Run by Illuminating Gas

New York's first motor car to be driven by the power of artificial gas has arrived. It made its appearance in the streets of New York recently, and, although its coming marks an event in the automobile history of this country—for it is the first car of its kind to be operated in America, as well—thousands of New Yorkers who have seen it running about town have passed it by without observing anything unusual in its appearance.

The fact is that this artificial-gas-propelled car is so little changed in its outward looks from the ordinary gasoline kind that the metropolitan public, generally so keen for novelties and sensations, hasn't been able to detect any difference. There is a difference, however, slight as it is. Along the running board on one side of the car is an unobtrusive steel cylinder from which the gas is fed to the engine and which furnishes it with its motive power.

Owing to the abnormally high price of gasoline and to the urgent need of saving every ounce of that liquid fuel for the use of motor vehicles and motor transport, motor cars operated by artificial gas have come into wide and steadily growing popularity in the British Isles in the last two or three months. There is, of course, no chance of their displacing gasoline-run cars in the United States under present conditions, or so long as gasoline does not mount up around the thirty-cents-a-gallon mark.

The car selected by the gas company's experts for changing over to the new form was one of a number of passenger cars which have been in the company's service for some time. Its total weight was about 4,800 pounds, and its average running ability was about six miles to a gallon of gasoline.

To the running board of the limousine was fitted a steel tank of 3 in. internal diameter by 45 in. long. This tank is provided with two ½ in. connections, one for charging and the other for delivering the gas to the carbureter. On the delivery line are placed a high-pressure regulating valve and gauge, so located that the chauffeur can conveniently adjust the regulator from the driving seat. The steel gas container is charged with gas at approximately 100 pounds pressure. While on this particular car the gas container is placed along the running board, there is no reason why it could not be, if desired, placed with equal

advantage on the rear of the car, or of any other car which it might be desired to change over to the artificial gas method of operation.

The experiments which William Cullen Morris, construction engineer of the Consolidated Gas Co. of New York, and his assistants have made with New York's first car to be operated by artificial gas, have shown that, roughly speaking, about 226 cubic feet of gas would ordinarily be required to do the work in motor propulsion of one gallon of gasoline. In the case of this particular limousine, however, which weighs 4,800 pounds, it has been found that 273 cubic feet are the equivalent of a gallon of the liquid fuel. Far greater efficiency would be obtained with a compressing plant specially built and a motor car specially equipped. The mileage of a car running on artificial gas would depend largely, of course, on the quality of the gas, and with an increase in the pressure of the gas in the container up to around 1,800 to 2,000 pounds, a good many miles could be covered on a single trip without refilling the tank.

### Motor Car Conditions in Scotland

In writing about general business conditions in Scotland in 1916, Consul Rufus Fleming has this to say about the motor vehicles:

All Scotch manufacturers of motor vehicles were working exclusively on government orders in 1916. The Scotch agents of American makers of pleasure cars and also of commercial cars had to contend with serious obstacles last year. The impost duty of 33 1/3 per cent ad valorem and the tax on gasoline of 24 cents per gallon (bringing the price up to 52 cents per gallon) greatly hampered the trade in vehicles for private use, but fell far short of stopping it. Prohibition of the importation of pleasure cars in the spring of 1916, the restrictions imposed later upon imports of commercial cars (requiring a license from the board of trade), and the further increased cost of gasoline to users (79 cents per gallon), would have made business impossible had there not been important stocks of cars and trucks in this country and had not fairly satisfactory substitutes for gasoline appeared. American types of cars, vans, and trucks not only maintained their reputation for reliability and durability, but enhanced it, and have a strong position in the market, which will enable the agents to take full advantage of opportunities in the future under normal conditions.

### Five Ways to Save Coal

Business men throughout the country are urged by the National Chamber of Commerce to help reduce coal requirements by getting full heat value of fuel and using supplies which are nearest. The following five suggestions are made:

1. Inquire into the methods employed by your fireman and consider his methods in relation to those suggested by the Bureau of Mines.
2. Learn what plants in your locality secure the best results from coal.
3. Endeavor to have the wasteful users of coal profit by the best experience of the locality.
4. Improve all local methods by consultation with the Bureau of Mines and study of the stoking methods recommended by the bureau.
5. Buy your coal as near home as possible.

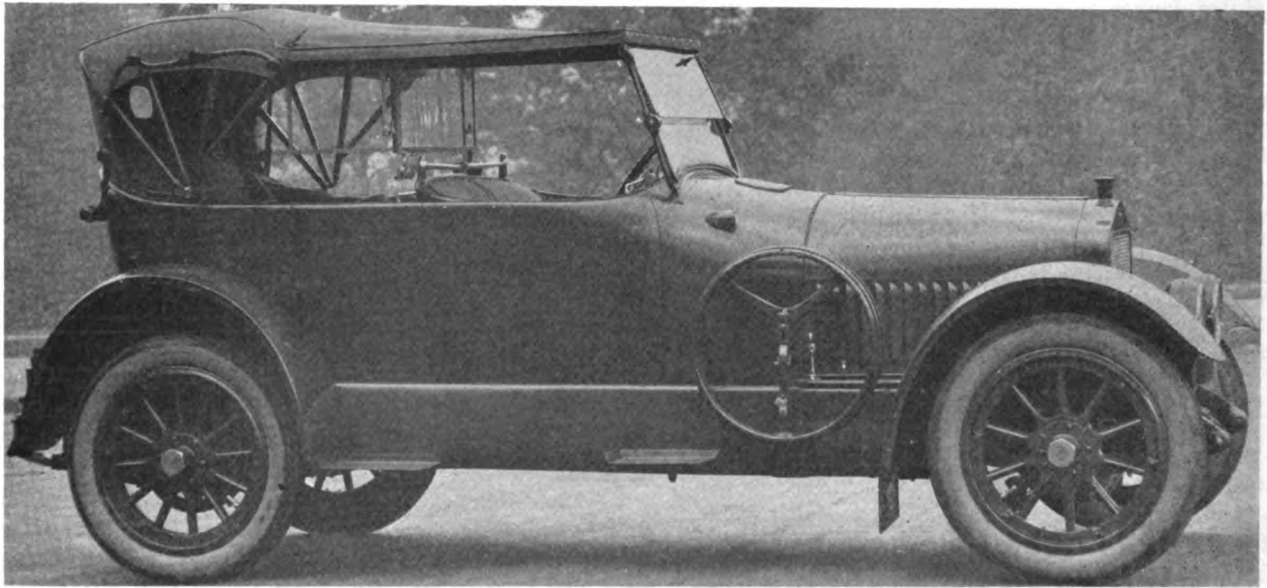

**FOUR-PASSENGER CAR WITH VICTORIA TOP AND TONNEAU WINDSHIELD**

**Body by The Rubay Co., Cleveland, O., mounted on White chassis**

This photo shows the car with windshield and victoria top up, as well as an extension curtain from the top to the front windshield. The photo below shows the car with top and windshields down. Note the perfect streamline of body.

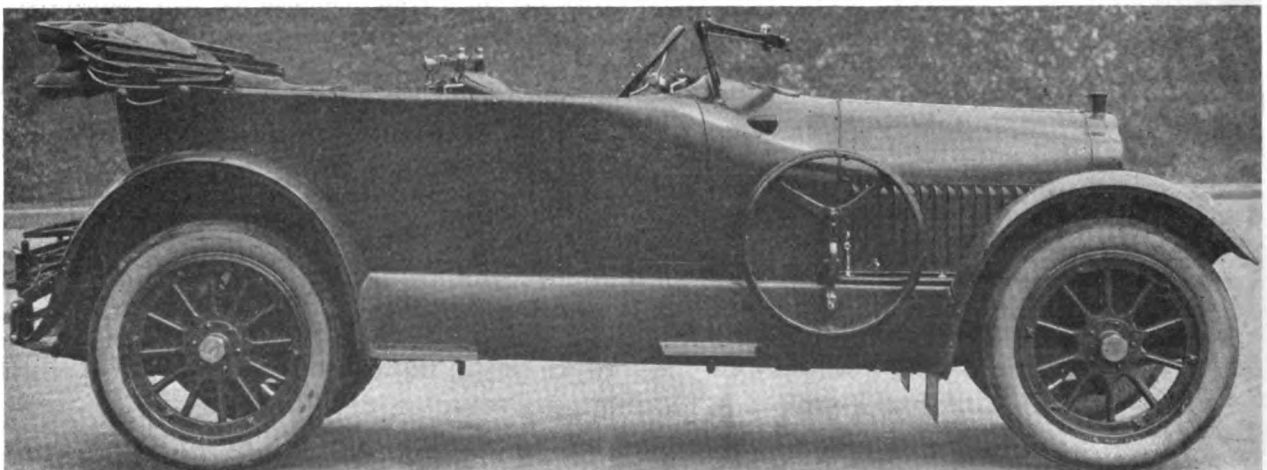

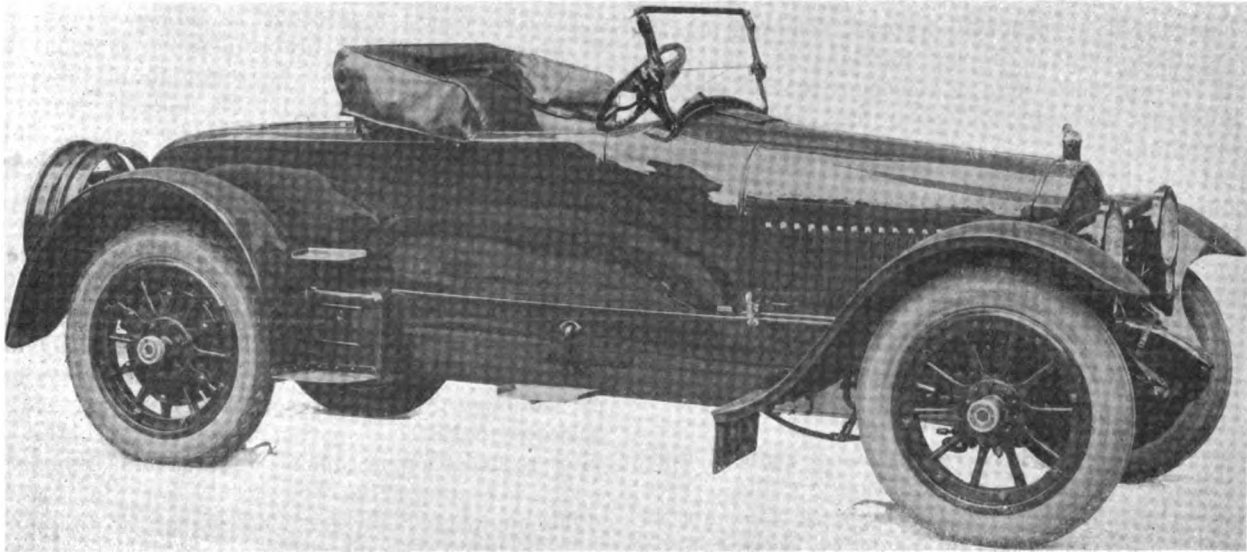

**SPECIAL ROADSTER**

Body by The Rubay Co., Cleveland. Mounted on Packard chassis

The extra seat folds flush into the rear compartment, one of the doors forming the back of the seat and the other the seat cushion when opened up.

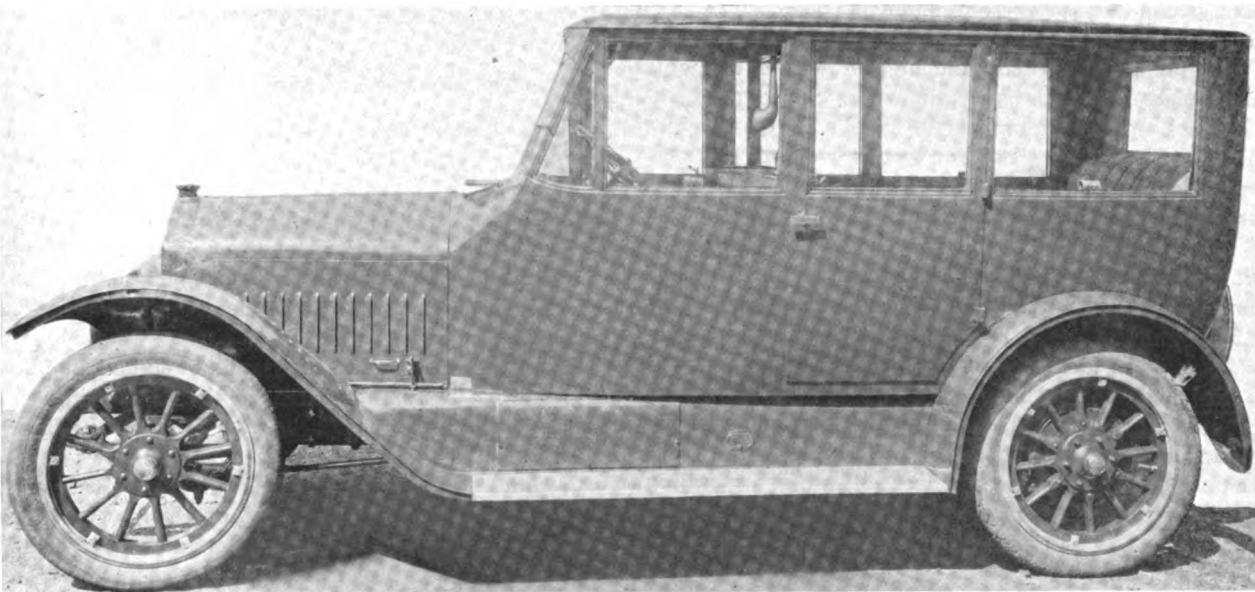

**SEVEN-PASSENGER SEDAN WITH DIVISION**

Body by The M. Armstrong Co., New Haven, Conn. Mounted on National chassis

Trimmed in imported cloth, with corner reading lights, concealed cases. Perfect window regulators, on doors, front seat trimmed in black leather.

## What Is the Future Car?

Frequently I have been asked, "What is the future car? Where is development leading us?" It is not an easy question to answer.

The development of an art is always toward the ideal, and by the same token the development of automobiles would naturally be toward the ideal car. There is no car, of course, that is the ideal, but nevertheless there is a standard of car performance and construction that is highly idealistic and may, indeed, be the goal for which we are heading.

Heretofore, the high-priced car has made luxury and easy riding the ideal condition toward which it is working. The lower-priced car has made economy and stability its ideal. There has never been in this country, however, a car that has been high-priced enough to make it the best in materials and workmanship that money can buy, and which is small enough and light enough to be as economical as the lower-priced.

### Future Car Economical

It is a prediction that is based on what is right in engineering design that the car of the future is going to be a car that incorporates the fundamentals of economy as well as the other essentials in its design, writes Merle Shepard, in the *New York American*. The habit of economy is growing in the United States, and it is one of the few blessings which can be traced directly to the war. We can never do without automobiles. They are a part of our national life, and a United States without automobile transportation would be a United States that has been slowed up in its efficiency by 50 per cent. Nevertheless, we are going to demand that our engines give us every last bit of performance that is possible. We are going to know that every inch of the length of the car has been accounted for to some good purpose.

Over-sized engines mean weight, abnormally long cars mean weight, and weight is the biggest foe to economy that the car can have. It is weight which checks acceleration, or pick-up, as the motorist calls it. It is weight which makes the tires wear out. It is weight that uses gasoline and causes the oil bills to run above par. It is weight that causes mechanical wear.

We have five-passenger cars that have a wheelbase of 100 in. We have other five-passenger cars that have a wheelbase of more than 130 in. Wheelbase length weighs about 50 pounds to the inch, after 100 in. is passed. Somewhere there is an ideal length for a five-passenger car, at which the best performance can be secured with easy riding, quick acceleration, plenty of leg room for the passengers, plenty of leg room for the people in the front compartment, and no waste of space. If we are spending money for gasoline to carry excess length and weight around that is not being repaid in some kind of service, we are wasting it.

The car of the future will weigh less for a given horsepower. It will weigh less for each passenger carried. It will, consequently, travel further for a gallon of fuel, on a set of tires or a given quantity of oil.

### Better Upholstery

Easy riding will be secured with better upholstery springs. These are slighted on a great many of the lower-priced cars. On the higher-priced jobs we are just beginning to get the proper upholstery. For some reason it has not been realized that the springs in the upholstery

have just as much to do with the comfort of the passengers as the springs beneath the car. It is the springs in the upholstery that really iron out the small inequalities in the surface of the ground. The larger springs beneath the car take up the main shocks, but good upholstery springs will make a car ride far better.

The car of the future, in fact of the near future, is going to be better adapted to heavy fuels. It is going to start easier because there will be some means, electrical or otherwise, of properly priming the mixture. At the coming show you are going to see electric primers that have done wonders for the hard-starting question. These primers preheat and start boiling a preliminary supply of gasoline, enough to get the engine started, after which it will readily run. Other primers force a finely divided spray into the cylinders.

Each succeeding year sees cars which are easier to take apart and repair. It is absurd to have to pay for five hours' labor on a job that takes 15 minutes, simply because the car is so designed that it takes two hour and a half to reach the affected part and two hours and a half to put it together again. This is another improvement which is slowly coming about.

The public generally gets what it wants in an automobile as well as in everything else. Just now the matter of economy has been added to the other requirements. This economy means not only economy in running the car but in maintaining it. It means that the car will do the work and yet will not be any larger than it is necessary to have the car in view of the performance wanted.

The biggest car is not always the best hill climber. In fact the lighter the car proportion to the output of the engine the better the car will climb the hill. If the car weighs 100 pounds for every horsepower, the hill climbing ability and the acceleration, or pick-up, are not going to be nearly as good as if the car weighed only 60 pounds to the horsepower.

### Future Car Will Travel in Air

There is little doubt but what the real future car will travel in the air. This is just a little too far for us to see now, but some day the key is going to be found that will unlock the secret of making a slow-flying, heavier than air machine. At the present time there are no machines that will land at a speed of much lower than 45 miles an hour. This means that good clear landing places are an absolute necessity.

When the war is over, thousands of skilled air pilots will be released to fly the machines that are going to carry passengers and express packages. The art of aviation has advanced in the last three years faster than we have dared to let ourselves think. Accidents in plain flying are rare; it is only when doing the fancy dips, spins and loops that any real risk occurs. The small number of accidents in our aerial service illustrates this fact very clearly.

The air car is doubtless the real car of the future, but before that time comes we will have developed land cars to a higher extent than they are now. A much better performance and greater horsepower will be secured from smaller motors. The smaller motors will be lighter and shorter, permitting of a lessened chassis weight, smaller tires, etc., and yet the amount of room in the tonneau will not be cut down because the length will be gained in the shorter hood and cowl and an all-around reduction of wasted space.



# New York a Center of Auto Manufacture

## Steady Growth of Manufacturing and Assembling Plants Located Within the City Limits of Greater New York

WHILE a great many motorists have no doubt considered New York as one of the chief, if not the foremost of markets, for the sale and distribution of automobiles, it is hardly likely that many of them realize the actual status of this city, not only as a sales mart, but as a locality where the assembling, manufacturing, and service branches of the industry have developed to a remarkable extent. As a sales center, New York is actually the center of the country, practically every motor car manufacturer in the country maintaining a branch office in this city. There are more automobiles sold, it is said, in New York City than in any other four or five cities in the country combined.

In connection with the vast sales of cars in this district it is but logical that a considerable growth of service stations, assembling plants, and the like should develop. Fortunately there is within easy reach of what is termed "automobile row" ample space for the establishment of such plants. This territory is located in Queensboro, just across the Fifty-ninth street bridge from Manhattan. Transportation facilities are of the best, both for the receipt and dispatch of manufactured products and for the securing of skilled labor of all varieties.

As a result of the excellent facilities provided, Queensboro has been the scene of extensive development and steady growth, far beyond what is perhaps generally

known. According to an article in the automobile number of "Queensborough," the monthly publication of the Chamber of Commerce of the Borough of Queens, New York City, during 1916 the sales of the 42 manufacturing, assembling, service and accessory plants located in Queensboro, amounted to \$37,448,000.

### Definite Economic Reasons

These manufacturers have built their plants here for very definite economic reasons. Comparative cheapness in production, in assembling materials, the relation of the Port of New York for export advantage, the coastwise shipping facilities, the great rail transportation systems, give Queens Borough a unique position as a manufacturing and distributing center. It draws its labor from all parts of the enormous labor market of the largest city in the world, made quickly available by a network of rapid transit lines at a five-cent fare.

The most important factor in automobile construction is the cost of assembling parts and materials. Some 280 different kinds of manufactured articles have a place in automobile construction and a considerable number of manufacturing plants specialize in each of these articles.

In the gathering together of the parts needed for automobile construction, the manufacturer in the New York area has at his command the largest available supply of

AUTOMOBILE ESTABLISHMENTS IN QUEENS BOROUGH			
(Prepared by the Chamber of Commerce of the Borough of Queens)			
Company		No. Employees	Date Located
General Vehicle Company		1600	1905
Brewster & Company		800	1910
Ford Motor Company		755	1910
Harrolds Motor Car Company (Pierce-Arrow)		275	1913
Packard Motor Car Company		260	1909
Autoped Company of America		100	1916
Rolls Royce, Limited		100	1917
Simplex Motor Company		90	1912
Renault Freres		80	1916
Studebaker Corporation		75	1916
Rainier Motor Corporation		40	1916
Maxwell Motor Company		25	1913
Transport Tractor Company		6	1914

ACCESSORY PLANTS IN QUEENS BOROUGH			
The parts and accessories plants in Queens Borough are shown in the following chart:			
Company	Accessories	No. Employees	Date Located
American Ever Ready Company	Batteries and electric equipment—flashlights	1600	1915
American Hard Rubber Company	Rubber Parts	1000	1884
Empire Art Metal Company	Tubing	850	1913
Brewster & Company	Bodies	800	1909
Humboldt Manufacturing Company	Miscellaneous parts	90	1914
Piel Manufacturing Company	Horns and catorts	125	1911
Metal Stamping Company	Miscellaneous parts	250	1911
Stewart Company	Automobile parts		1916
Goodyear Tire and Rubber Company	Tires—Service	55	1915
Prest-O-Lite Company	Acetylene gas, storage bat.	20	1910
Auto Specialty and Equipment Co.	Auto hardware	4	1910
Fickling Enameling Company	Enameling bodies	60	1915
Moto-Meter Company	Motometers	40	1916
H. & N. Carburetor Company	Gas and kerosene carburetors	35	1916
Norma Company of America	Fall bearings	200	1916
Anthony Machine Company	Oil guns and pumps	24	1912
Walton Body Company	Bodies	12	1917
Plaza Auto Top Company	Tops	3	1916
C. A. Willey Company	Auto varnishes and colors	75	1880
Fahnestock Electric Company	Electrical parts	14	1916
Seubert Bearing Company	Bearings	25	1915
Astoria Wire Company	Insulated wire	4	1913
Kates Machine Works	Valve tops	4	1909
Queensboro Brass and Bronze Co.	Castings	25	1903
Merrell Brothers	Drop forgings	100	1906
Akron Tire Company	Tire service	40	1913
Cobal Manufacturing Company	Electrolytic copper articles	4	1916
United Specialties Company	Nickel plates	16	1915
Russell McGee Foundry Company	Castings	65	1913

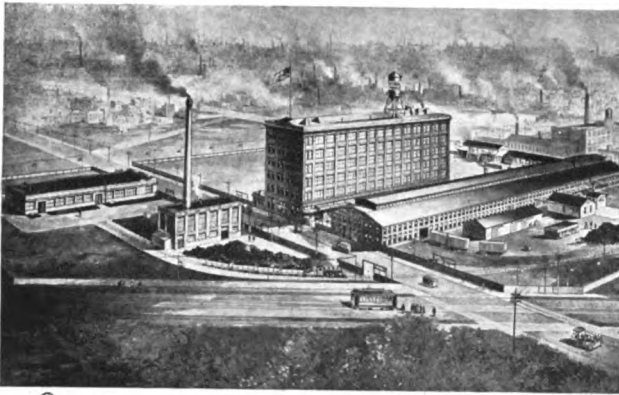

Plant of General Vehicle Co., electric truck builders

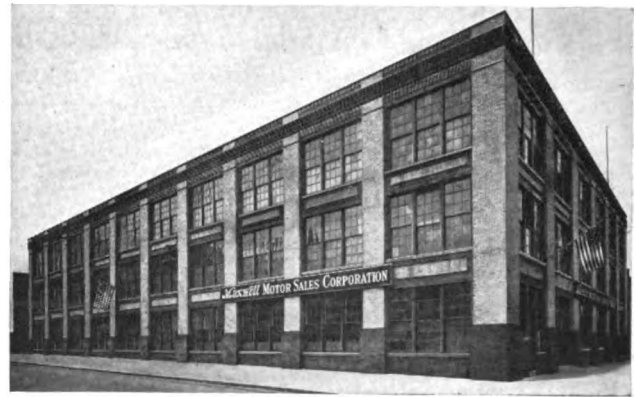

Maxwell Motor Corporation's service station

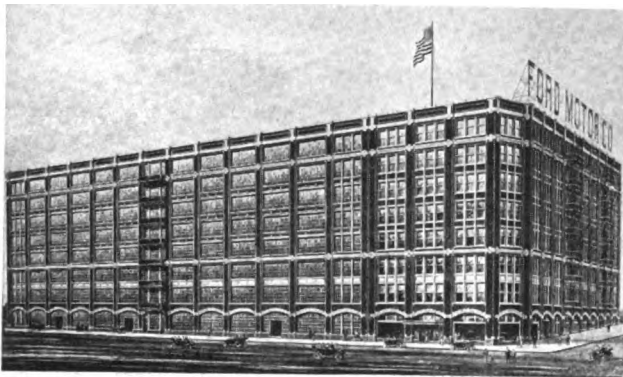

Ford Motor Co. assembling plant



Packard Motor Car Co.'s service station

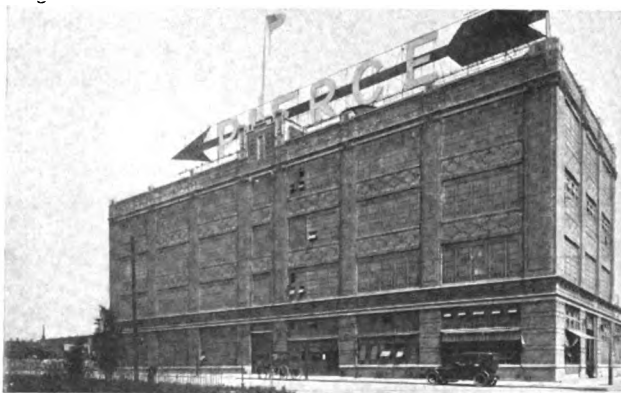

Harrolds Motor Co. (Pierce-Arrow) service station



Plant of Rainier Motor Co., truck builders



Studebaker Corporation's service station

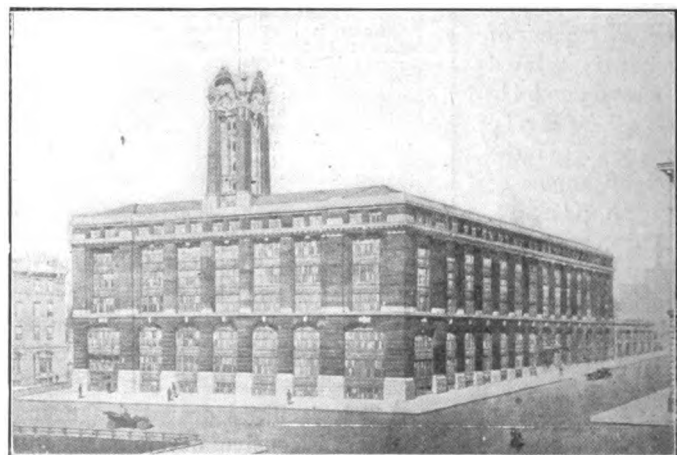

Plant of Brewster & Co., high grade automobile builders

parts, materials and accessories. In this respect no other city in the country equals New York as an economic assembling point for automobile construction.

A large number of these plants producing parts and materials used in automobile construction are located within the limits of the City of New York, and their products are available for quick and cheap delivery by motor dray.

In the production of automobiles there is a marked trend toward the east.

Two salient features of the situation makes the eastern trend entirely logical.

First—Thirty-two per cent of the motor vehicles manufactured in the United States are either sold in the 18 Atlantic seaboard states or must be shipped to the seaboard for export.

Second—The development of parts manufactured in these eastern states has made the assembling of material for motor vehicle production as economical and advantageous for an automobile manufacturer in New York City as for the manufacturer of automobiles located in the middle west.

#### Logical Condition

The cost of transporting a complete automobile by rail half across the continent represents a large additional burden upon the buyer, and yet the illogical condition exists that while less than 6½ per cent of the total number of motor vehicles produced in 1916 were manufactured in the east, 32 per cent of the total sales of cars were in the east, including those exported from Atlantic ports.

This condition applies more particularly to passenger vehicles as only two per cent of the total production of pleasure automobiles in 1916 was produced in the eastern states.

In view of the fact that those states lying between the Alleghenies and the Rockies purchased only about 59 per



American Ever Ready Works

cent of the motor vehicles manufactured, and since only about two per cent of the pleasure vehicles of the country were produced in the eastern states, it is obvious that fully 41 per cent or something over 600,000 pleasure automobiles had to be transported half across the continent from their place of manufacture to their market, although they might have been manufactured just as economically within the heart of their market, with the result that a large saving would have been effected in transportation costs.

Of the 92,000 commercial vehicles produced in 1916, 42,101, or over 40 per cent of the total, were made in plants located in Atlantic seaboard states, and it is likely that the percentage of eastern production will be still greater in 1917.

Considering the immense market for commercial trucks in New York and its nearby territory and considering the constantly increasing export business in such vehicles, New York City will soon become the center of the commercial truck industry of the country, and will pass Detroit in the production of this class of motor vehicles. The estimates of the producers of commercial vehicles in the New York

area indicate a total production in 1917 in this territory of over 29,000 cars.

These favorable conditions for economical production and distribution have resulted in the establishment in Queens Borough of 13 automobile manufacturing, assembling and service plants, and 29 accessory and parts concerns.

#### Thirteen Auto Plants

Among these 13 plants is that of the General Vehicle Co., which employs up to 1,600 men and has a gross annual production valued at more than \$6,000,000. This plant produces the high class Mercedes truck and a complete line of G.V.

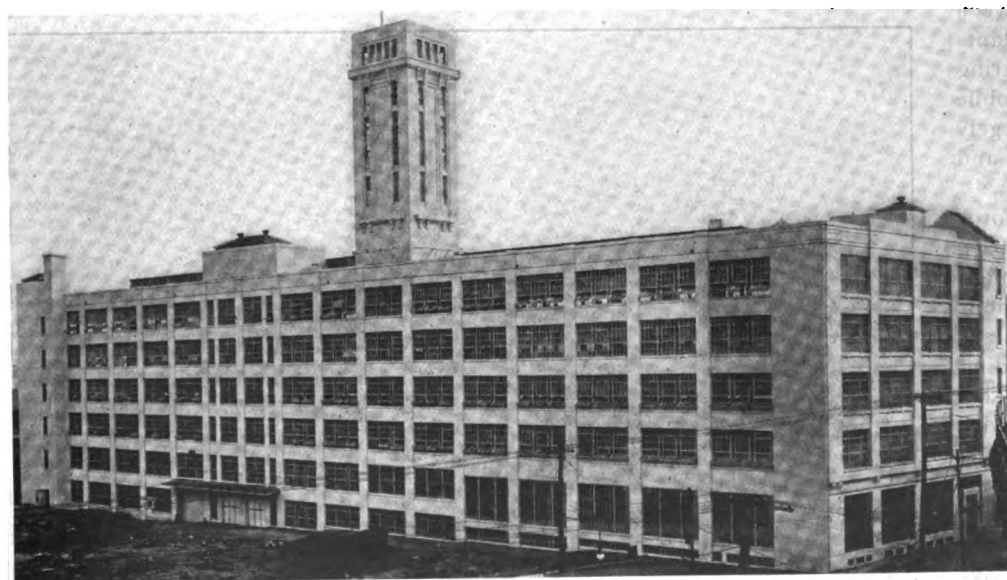

Model daylight factory of J. K. Stewart & Co., auto parts manufacturers

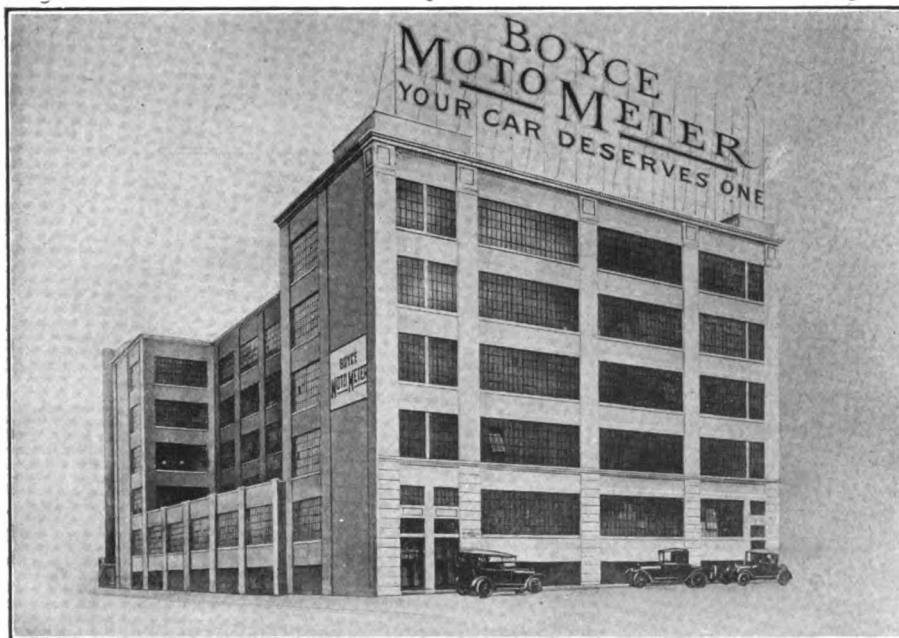

Building of Moto-Meter Co., manufacturers of motometers

electric commercial trucks. The rapid growth of this company is indicative of the advantages of Queens for automobile manufacture. This company started in Queens 12 years ago in a two-story building 100 x 500 ft. in dimension. They now have four additional buildings with a total floor space of 350,000 sq. ft. In addition to the 100 trucks per month, they manufacture high class airplane engines.

Brewster & Co., whose name has been famous for years in the vehicle industry, have developed a pleasure automobile of high merit, and occupy a large factory building on Queensboro Plaza, where they employ more than 800 men. They were one of the first automobile concerns to recognize the value of locating in Queens Borough. They have developed the manufacture of a passenger car and are extensive builders of high class automobile bodies.

Large corporations whose main plants are in the middle west, have found it of advantage to establish large assembling plants in Queens to reduce to a minimum the cost of rail freight charges on completed automobiles. It is difficult to draw the line between one of these large assembling plants and an automobile manufacturing establishment, since automobile manufacturing anywhere is largely a matter of assembling of parts and finishing.

For example, the Packard Motor Car Co. has occupied since 1909 a factory building in Queens Borough comprising 150,000 feet of floor space and is just completing an addition to this building, affording them a total of 325,000 sq. ft. This is called an assembling and service plant and yet it employs 600 people, and when the new addition is completed this force will be doubled.

The Ford Motor Car Co.'s assembling and service plant employs nearly 800 men in a nine-story

building containing nearly 1,000,000 sq. ft. of floor space. Forty thousand cars are turned out annually from this factory. This means 150 cars per day. The Ford factory in Queens was originally established in 1911, with three stories and a basement, but in 1913 it became necessary to add five additional stories to the original structure. During 1914-15 a further addition was made, which is about three times as large as the original eight-story building. This is one of the largest industrial plants in the Borough of Queens, and the largest building devoted to the use of the automobile industry in this section of New York City. Very few European motor car factories turn out as many cars in a year as does this assembling plant, which supplies only the territory controlled by the New York City branch of the Ford Motor Co.

The Pierce-Arrow plant of the Harolds Motor Car Co. in Queens employs nearly 300 workers. Their original plant included a floor space of over 10,000 sq. ft. in a four-story factory costing approximately \$400,000. In 1916 the business of this company had increased to such an extent that additional land, 118 x 200 ft., was purchased by the company for the purpose of enlarging the present capacity. The modern well-equipped factory of this company is a fine addition to the many automobile plants now located in Queens Borough.

The Studebaker Corporation employs more than 200 men in a big assembling and service plant, built especially for their needs, at the Degnon Terminal in Queens Borough. This company found their present location of such advantage that six months after opening, demands of business made it imperative for them to extend their factory accommodations.

The Simplex, another high class pleasure automobile, has an important assembling and service station in Queens. They have added another story to their original building during this year.

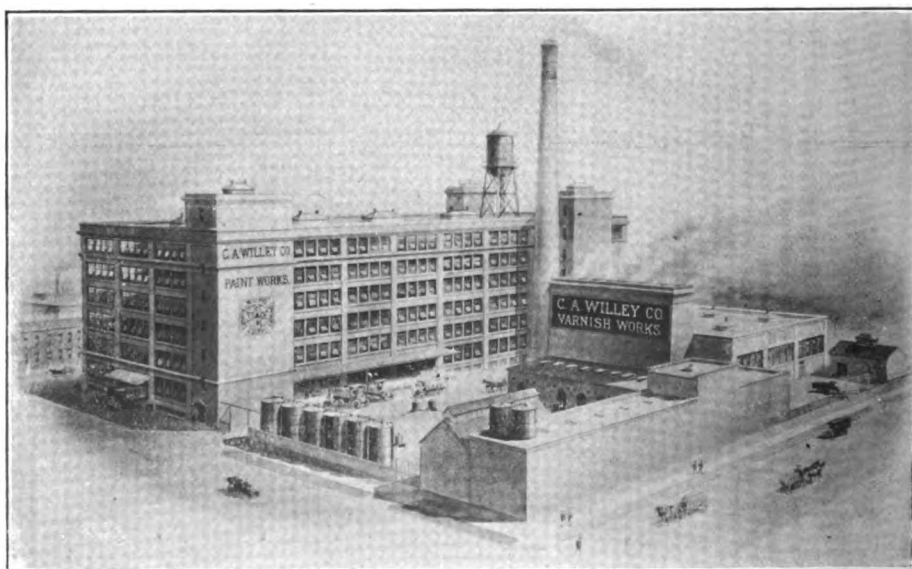

C. A. Willey Co. factories, automobile paint and coach colors. Established 1880



The Maxwell Motor Corp., who now operate a large service plant in Queens, are planning to erect an assembling plant in the same vicinity.

Renault Freres, Delauney-Belleville, Rainier Motor Corporation and the Transport Tractor Co. are automobile corporations operating plants of considerable size in Queens.

The Rolls-Royce Co., Ltd., of London, is the latest of the automobile assembling plants to locate in Queens. In May they purchased a plot 100 x 150 ft., upon which they will erect a four-story service station at a cost of \$100,000.

#### Accessory Plants

In addition to the 13 manufacturing, assembling or service plants in Borough of Queens, there are 29 important manufacturing plants devoted to the production of automobile parts and accessories and these plants employ more than 5,000 workers. The products of these plants in 1916 were valued at \$13,488,000.

Some of the manufacturers have taken advantage of the facilities of Queens Borough by building up important service stations there.

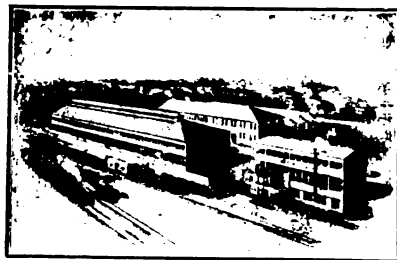

Merrill Bros. Works, drop forgings

The Goodyear Tire & Rubber Co. has realized the value of having a distributing point near the key of the eastern market, and in view of this has a \$400,000 structure on a 300 x 150 ft. plot. The Akron Tire Co., located at Honeywell avenue and Skillman street, has a service plant in Queens.

Included within the section occupied by many of the best known plants in Queensboro is the factory of the C. A. Willey Co., manufacturer of carriage, automobile and car paints, and varnishes of a long established high standard. This firm was established in 1880 and its trade mark is known throughout the country as a mark of excellence. The business has been at home in this location for many years—in fact is the pioneer—and forms a component part of a rapidly growing center of the automobile industry in the east.

Another business closely allied to the automobile trade is that of the Empire Art Metal Co., makers of Empire steel tubing, a product especially prepared for, and largely used in the manufacture of automobiles, auto trucks, motorcycles, bicycles, etc.

#### Australia Needs Motor Car Bodies

Consul General J. I. Brittain, Sydney, New South Wales, under date of September 26, writes that efforts are being made to obtain permission to import bodies for motor cars into Australia to supply the demand until such time as domestic factories can be equipped to manufacture them in sufficient quantities. It is pointed out by those interested in the trade that at least 10,000 bodies will be required within the next year, and that it is extremely doubtful whether one-fifth that number can be manufactured in Australia with the factories' present equipment. The normal output of motor car bodies in Australia is estimated at 1,100 a year.

#### Executive Committee Meeting of C. B. N. A.

At the meeting of the executive committee of the Carriage Builders' National Association held at the Hotel LaSalle in Chicago on October 25, P. E. Ebrenz was elected chairman for the ensuing year and it was decided to hold the next meeting of the association in Cincinnati, September 23 to 28, the Hotel Gibson to be headquarters.

There will be only two regular sessions of the convention, which will be held on Tuesday and Thursday morning, with a special meeting of the carriage builders at 3 o'clock Wednesday afternoon. This is done to give more time to the exhibition.

Mr. Ebrenz was selected as a representative of the association as national counselor in the National Chamber of Commerce.

The following terms were fixed for the newly elected members of the executive committee: W. H. Roninger, Theodore Luth, W. E. Maxwell, Frank H. Delker, to serve the regular term of three years; A. C. Hill, to serve two years, filling out the unexpired term of T. M. Sechler; E. J. Schlamp and W. G. Norman, one year, filling out unexpired terms of J. D. Dort and C. O. Wrenn.

A war committee was appointed, carrying out the resolution adopted at the war convention held at Atlantic City in September that each industry should appoint such a committee and that in all matters pertaining to any given industry the government should deal with this committee wherever possible. The committee consists of Philip Ebrenz, chairman, Reliance Buggy Co., St. Louis, Mo.; W. H. Roninger, Banner Buggy Co., St. Louis, Mo.; C. R. Crawford, Moon Bros. Carriage Co., St. Louis, Mo.; Frank Delker, Delker Bros. Buggy Co., Henderson, Ky., and E. J. Schlamp, George Delker Co., Henderson, Ky.

A resolution was passed declaring the meetings of carriage manufacturers during the year a great benefit to the trade, and Chairman Ebrenz was authorized to call these meetings in the future.

The Hotel LaSalle was thanked for the able manner in which it handled the 45th annual convention held in Chicago in September.

The following members were present: W. H. Roninger, W. A. Sayers, F. H. Delker, Ed. J. Schlamp, C. R. Crawford, T. M. Sechler, P. P. Hunter, P. E. Ebrenz, Theo. Luth, O. B. Bannister, Homer McDaniel.

#### American Automobiles in Peru

The unusual prosperity of Peru during the last 18 months has been reflected in the favorable automobile business of Lima and other cities of the republic. An improvement in the roads in the suburbs of Lima may be attributed also to the larger number of sales of American cars during the latter part of 1916 and the first half of 1917. During 1914 and 1915 the demand was principally for low and medium priced machines, but with the general prosperity now quite evident the demand is for higher grade cars. Within recent months some of the finest American cars have been properly exhibited, and the sales have been very satisfactory. No less than 25 cars of different American manufacture are now to be seen on the streets of Lima. The total number of cars in Lima is about 600. Shipments of automobiles from the United States ports to Callao should be made by direct steamer, thereby avoiding transshipment, possible damage, and delay at the Panama Canal.



## Motor Car Manufacturers Pledge the Facilities of Their Plants to the Government

At their meeting in Detroit November 20, in answer to a call from the National Automobile Chamber of Commerce, more than 150 automobile manufacturers voted unanimously to support the work of the Automobile Industries Committee at Washington, pledged to the War Industries Board and the War and Naval departments their heartiest support and to a man expressed their readiness to turn over the vast productive facilities of the industry to the government as fast as the government can make use of them. In the meantime, automobile makers will keep their organizations intact so as to conserve the greatest possible potential strength for the present and future war programs of the government. President Chas. Clifton, of the N. A. C. C., presided, with every prominent company in the industry represented and also representatives of the Motor and Accessories Manufacturers' Association.

That the Washington authorities had no intention of arbitrarily cutting off the automobile business was clearly shown, also that automobile men themselves have offered to reduce passenger car production according to the government needs for war materials, or as the government may require the facilities of the automobile and accessory manufacturing companies. The heartiest response to the committee's efforts has been received from the War Industries Board and from the Army and Navy departments.

### War the Nation's Principal Business

Manufacturers appreciate that business cannot be entirely as usual during the war, as the principal business now is making war and not making automobiles, so that the industry cannot expect to increase production as in the past.

Rather than give munition orders to companies which have to buy new machinery and build new plants, it is realized that advantage should be taken of the productive capacities of the automobile and parts plants. An immense amount of war work is being done for the government and preparations are being made to take over more work.

A. W. Copland and Hugh Chalmers, of the Automobile Industries Board, who, with John R. Lee, were appointed to co-ordinate the government war facilities of the automobile industry, explained the work going on at Washington. Their need for additional engineers was promptly answered by nine manufacturers volunteering the services of nine of their engineers to work with the committee at Washington for the period of the war. Manufacturers attending the meeting were surprised at the great number of automobile men in the service and the spirit of co-operation which has been shown by the makers giving their best men to the government at great sacrifice to themselves and their plants.

Transportation for millions of people and thousands of tons of freight as supplied by the modern motor car and truck, coupled with the war railroad's board request for greater motor transportation to relieve the railroads of short haul traffic, demands, it was felt, continued productive facilities in the industry, now rated as third among those of the United States.

### To Aid Government

By unanimous vote of the meeting the following tele-

gram was sent to Daniel Willard, chairman of the War Industries Board at Washington:

"The automobile industry, as represented by more than 150 manufacturers in session here today, volunteers its hearty support to our Automobile Industries Committee in Washington and pledges to the War Industries Board and the War and Naval departments their heartiest support, and to a man expressed their willingness to turn their facilities over to the government as fast as the government can make use of them. In the meantime we hope to keep our organizations intact so as to conserve the greatest possible potential strength to the present and future war plans of the government."

Some interesting figures were supplied the meeting which proved the far-reaching influence of the automobile industry. They showed 230 makers of passenger automobiles and 372 makers of motor trucks in 32 states, with a capital investment of \$736,000,000 and with 280,000 workers, to whom \$275,000,000 in wages and salaries is paid annually. The production for the year ending June 30 was 1,806,194 motor vehicles, of which 112,200 were trucks, the total value of both being \$917,470,938.

There are 1,080 manufacturers of bodies, parts and accessories with a capital of \$336,000,000, employing 320,000 workers and paying \$288,000,000 annually in wages. Last year 18,000,000 tires were made, valued at \$450,000,000. There are 27,800 automobile dealers and 25,500 garages, located in almost every town and village of the United States, all dependent on the production of motor cars. They have a capital investment of \$184,000,000 and employ 230,000 people.

Exports for the year ended June 30 were 64,834 passenger cars and 15,977 trucks, the latter mostly for our allies in Europe. The value of these exports, including tires and parts, was \$133,411,000. There are now 4,500,000 automobiles registered in the United States, of which 400,000 are trucks which are annually transporting goods to a total of six billion ton-miles and relieving the railroads of short-haul traffic.

### Hardwood Association Meets in February

The board of governors of the Hardwood Manufacturers' Association of the United States has called its sixteenth annual meeting to be held at the Hotel Sinton, Cincinnati, O., Tuesday and Wednesday, February 5 and 6. It is the purpose of the association to make this meeting one of much practical value to the producers and consumers of lumber. A program is being prepared with careful consideration of today's problems and conditions. The program will contain the names of several men of national reputation, experts in their respective lines.

### Mechanics Wanted in Navy

The Navy Department wants 8,000 men at once. An emergency call has been sent out for them. They are wanted for the ground personnel of the Navy Flying Corps. Their principal qualification should be skill in mechanical work; they must be first class mechanics. After enlistment they will be rated as machinists' mates, carpenters' mates, quartermasters, coppersmiths and blacksmiths. Each class will be given special training. Applicants must be between the ages of 21 and 35, and it is stated that promotions will be made as rapidly as the progress of the applicant warrants.

# Trimming a Limousine

(Continued from August)

In our last article we illustrated three styles of trimming for limousine doors. That on No. 3 door (Fig. 1), called a squab pattern, will now be dealt with. You mark off the inside edge of broad lace on the door, and then remove the canvas and proceed to mark off your pattern as previously described, Figs. 2 and 3.

After marking out the squab, then crease where the pleats are to be; then put it on a frame and button and stuff it, and finish on the door just the same as described for doors 1 and 2, remembering to keep all laces firm and straight. A good point for most trimmers is to put plenty of paste underneath the broad lace, so as to fix it firmly.

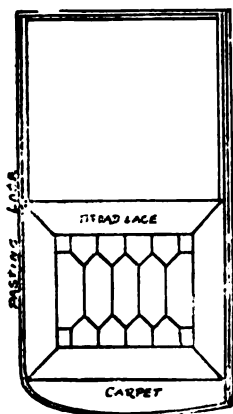
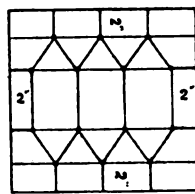

Fig. 1. No. 3 Door



Bottom  
Fig. 2.

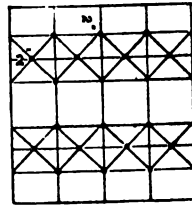

Fig. 3.



Fig. 4. Skewer

This saves a lot of tacking and stitching, which always look unsightly. Another point to know is—a good few trimmers stuff up underneath the broad lace or else put in some wadding to make a raised appearance, in other words, a roll; but the best finish is to get a piece of wood cut to fit underneath the lace 3/16 in. narrower than the lace, and cut to the shape of bevel at the corners, allowing about 1/16 in. clearance. The piece of wood is then nailed on with panel pins, which makes a firm and secure job.

### Cushions

Now we come to cushions. We will take the cushion of any inside car. The main point to keep in view is softness, while yet being firm and comfortable. First of all you take the pattern of seat with a piece of brown paper, and after having done that lay it on your bench. Allow 1 1/2 in. clearance at the back of seat and 3/8 in. at side. Mark out pattern of the design you intend to do, and then mark out a fullness pattern. Give the ground pattern, that is, the first pattern, to the smith to make the iron frame, so that there will be no waste of time when you want to fix it on the frame.

Having got your fullness pattern ready, lay it on the leather or material which you are going to use, mark out and cut, then punch the holes for the buttons with a No. 3 punch. Hammer the creases down, then it will be much easier and quicker to machine. Then tack your canvas on a frame securely, and lay ground pattern on

the frame and mark the exact size and shape of your cushion. Be sure to find out if there is any bevel on the seat. If so, you will have to put the same bevel on top frame (only), otherwise when the cushion is finished and put in the job it will look small and be a misfit, altogether spoiling the effect of your work. After cushion is marked out, instead of stitching on the line that you have already marked, make another line 1/4 in. larger all the way round, except the front; that is to allow for the contraction of the canvas on the frame when the cushion is taken off, otherwise you would never get the cushion to fit the iron frame.

After having sewn cushion all round except the front, you are now ready for the spring frame. Cover the bottom iron frame with canvas, and sew it all around. In putting the canvas on the frame put four skewers (Fig. 4), one in each corner to hold the canvas, while you stitch it. This saves a lot of time.

After having sewn on the canvas, next put on a piece of strawboard; but instead of sewing it on you put about half a dozen bifurcated rivets right through the strawboard and the canvas. This makes a secure job. Now mark on the strawboard the distance of your springs, and then rule the lines across to where you intend to put them. As a rule, in a cushion for a car such as we have been speaking about, it will take about four rows of springs and about eight in a row, making 32 springs in all. Sew these on to the bottom frame (that is, the frame which you have already covered) with strong twine doubled so as to make it secure, as the movement of the car and the working of the springs means a big strain on the stitching.

Sew the high springs on the front of the cushion and taper down to the back to the height you intend to have your cushion when finished, as in Fig. 5. Next cover top frame with canvas, skewering it on just the same as the



Fig. 5. Section of Cushion

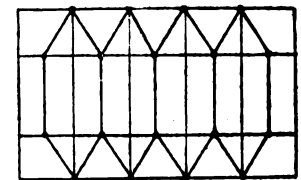

Fig. 6. Lay out for Cushion

bottom frame. Then stitch it. After having finished this, lay this frame on top of the springs on the bottom frame, but making sure your two frames are in a line one with the other. Next stitch the springs to the canvas of top frame, about four stitches in each spring with good strong twine. Measure off the height you want your cushion, back and front, when finished (allowing 2 in. for leather and hair), and tie down the frame accordingly. Now you put your spring frame bottom up, and sew cushion right around to the top of the frame; tip cushion up again, the bottom of the frame to the bench. It is now ready for finishing off. On the front edge sew a roll about 2 1/2 in. wide and about 1 1/2 in. high, and stuff up fairly firm with

hair, etc. Be sure to make it regular right along, as the finish depends a lot on the roll; now finish off at the ends, and commence to work leather over the roll, and pleat and stuff. This is a cushion with top and front all in one, there being no join in the front border. Having finished stuffing along the front, turn cushion over and stitch the leather to the bottom canvas. Now mark 4 in. from the top of cushion and put buttons in along the front, one to every pleat. This makes a finish, and also keeps the hair in position and the cushion in shape. Now sew a piece of duck on the bottom and put about half a dozen eyelets in to let the air out, and it also helps the cushion to ride more comfortably.—Coach and Motor Builder [Australia].

**Nebraska Repair Prices**

Repair prices are always interesting. The following are those of the Nebraska Blacksmith, Horseshoer and Wheelwright Association:

**Lumber Wagon Wood Work**

New pole complete.....	\$7.00
New axle.....	5.00
New bolster, old irons.....	3.00
New sandboard.....	2.50
Bent hounds, old iron.....	5.00
Hind hounds, old irons, each.....	1.75
Tongue hounds, old irons, each.....	1.50
Tongue put in old irons.....	4.00
Bolster stakes, old irons.....	1.00
Old style front hounds, one \$2.50; two \$4; cross bar.....	1.50
New skein, a set, D. V. pattern.....	12.00
New skein and box in wheel.....	3.75
Cutting down wagons, 1 1/2 x 2 1/2.....	\$12 to 15.00
Filling hind wheels.....	8.00
Filling front wheels.....	7.50
New rim and setting tires.....	3.50
Half rim and setting tires.....	2.50
Axle for separator.....	\$6 to 7.00
New bottom put in box, work.....	\$4 to 5.00
One cross piece on box.....	1.00
New side in top box, labor.....	1.50
Stop cleats.....	.50
End gate, common, 75c; patent work.....	\$1 to 2.00
New neck yoke.....	1.25
Wagon evener, \$1 without iron; with iron.....	1.50
Sawed felloes, each 50c; 3 for.....	1.25
Spokes, straight, 50c; 3 for.....	1.25
New hub in wheel, \$2.50; wood work.....	2.00
Wagon reach.....	\$2 to 2.50

**Lumber Wagon Iron Work**

Bolster plates.....	\$1.50 to 2.00
Pole caps.....	.75
Hammer straps.....	.40 to .50
Wagon wrench.....	.50
Hound plate, set, \$2.25; each.....	1.25
Draw bolt.....	.50
New box in wheel.....	1.00
Top iron on box.....	1.50
Box rods, each.....	.25 and up
Patent end gate lock.....	.35 to .50
Hind hound braces, new, each.....	1.25
New center clips on singletree.....	.35
New ferrules on singletree, each.....	.25 to .35
New neck yoke center.....	.50 to .75
New yoke ferrules, each.....	.25 to .35
Wagon singletree.....	.75 to 1.00
Seat spring.....	1.00
Seat hooks, set.....	1.00
New bolts in back bolster, each.....	.50
Welding circle iron for front bolster.....	\$1.50 to 2.00
Welding half circle.....	.75
Drilling and bolting on wheels, per bolt.....	.15
Steel coupling plates, each.....	.50
Cast coupling plates, each.....	1.50
King bolts, 3/4, 1 1/4, 1 1/2 each.....	.50 to .75
Rub iron, per pair.....	.75 to 1.00
Steel tongue plates.....	.50
Steel double tree plates.....	.25
Setting wagon tire, each.....	1.00
Setting wagon tire, a set of four, hot, \$4; cold.....	3.00
Setting 3 in. tires, \$4; 4 in. tires.....	5.00
Hub band, each.....	.50
New wagon tires, besides price of material, each.....	2.00

**Carriage and Buggy Wood Work**

Replace broken buggy tongue.....	\$4 to 4.50
New buggy tongue, complete.....	8.50
New side in shaft, each.....	\$2 to 2.50
New cross bar in shaft.....	1.50
New steel tips on buggy shafts.....	1.25
New pole circle, pole put in.....	2.00
Cutting down buggy wheels.....	12.00
One new spoke, 50c; three for.....	1.25
New buggy reach, straight.....	1.50
New buggy reach, bent.....	2.00
New buggy evener, painted.....	1.25
New singletree.....	1.00
Putting half rim in wheel, setting tire.....	2.25
Set box in new wheel.....	1.00
Set box in old wheel.....	.75
Straight pole cross piece.....	1.50

Neck yoke, wood put in.....	1.00
Singletree, wood put in.....	1.00
Axle beds.....	2.00
Spring bars.....	1.50
Side bars.....	1.50
Head blocks.....	2.00
Spring wagon pole, complete.....	8.00
Spring wagon seat, complete.....	4.00
Spring wagon box, complete.....	15.00
Seat raisers, each.....	1.50
Lazy back, open.....	1.75
Buggy shafts, black hickory.....	3.00
Buggy shafts, high back.....	3.25

**Carriage and Buggy Iron Work**

The above is for common half patent axles.....	
Concord axles, 1 1/4.....	20.00
Concord axles, 1 3/8.....	22.50
Concord axles, 1 1/2.....	25.00
Concord axles, 1 3/4.....	27.40
Concord axles, 1 3/4.....	31.25
Straighten buggy axle.....	1.25
Welding and setting broken axle.....	2.00
One new stub and boxing in wheels.....	3.50
Welding pole brace, 65c; new end on pole brace.....	1.00
Welding shaft iron, each.....	.75
New shaft or pole eye.....	.75
Rub iron, set.....	1.25
New clip king bolt.....	1.25
Shaft or pole coupling, 1 and 1 1/8 in.....	.75
Buggy clips, flat or square.....	.50
Welding spring leaf.....	1.50
New buggy spring, per lb.....	.20
New rim on buggy wheel, set tire.....	\$3 to 3.50
New fifth wheel.....	\$3.50 and up
Set buggy tire, each, 75c; set.....	3.00
Bolting, extra.....	.50c to 1.00
New singletree clevis.....	.50
Bow socket.....	1.00
New bow in top.....	2.00
New body loop.....	1.25
New shafts, complete.....	6.25
Set wheel dished wrong.....	1.25
Buggy tire, besides price of material, per set.....	8.00

**Automobile Work**

Single cylinder castings.....	5 to 7.50
Twin cylinder castings.....	10 to 15.00
Triple cylinder castings.....	15 to 20.00
Four cylinder castings.....	15 to 25.00
Six cylinder castings.....	20 to 30.00
Crank shafts, two cylinders.....	10 to 15.00
Crank shafts, four cylinders.....	20 to 25.00
Crank shafts, six cylinders.....	25 to 35.00
Axle shaft.....	.5 to 7.50
Timken rear axle housing or housings of light structure.....	.8 to 16.00
Malleable housings.....	.5 to 10.00
Welding exhaust manifolds (cast iron) where lugs are broken off.....	.75c to 1.50
Welding lugs on aluminum intake manifolds or water manifolds.....	1.25 to 2.00

**Miscellaneous**

All prices are regular sizes. Extra for heavy jobs. Labor by the hour means time only. Charges to be for all materials and stock used. First hour, \$1; after, 75c. Extra charges for helpers work. Breakage, destroying or losing tools to be charged to help unless unavoidable, or any person borrowing tools. When using power, labor and use of machine is worth \$1.25 per hour. On all odd jobs weigh the iron. Charge retail price per lb. for the iron. Charge up all bolts and rivets, retail price. Time on all dirty jobs, such as automobiles, mowers, wagons and all jobs that have grease, dirt, etc., commence when you go to work and should be charged for until the tools are cleaned and put away and your hands washed to give you a chance to make change. All book accounts are due every 30 days unless other arrangements are made. Any person not paying bills within 60 days will be charged for filing lien for work done.

**Speedy Motor Sleigh**

When a North Dakota inventor hitches up his "motor horse" he enjoys a sensation altogether unusual. It was first driven about the streets of Grand Forks and consists essentially of a motor wheel pivoted between a pair of sleigh runners, the rim of the wheel being equipped with studs, or spikes, which furnish rapid traction on either snow or ice. The driver may stand on skis or be seated on a sled or toboggan from 12 to 15 feet behind the "horse," being drawn along by two ropes, while other lines serve for starting, stopping, steering and regulating the speed. The complete machine weighs 51 pounds. A special gasoline motor is built within and geared directly to the driving wheel. At one time a distance of 103 miles through deep snow was covered in three hours and twelve minutes, with the driver on skis. Under more favorable conditions much greater speeds have been attained.

### Ingenious Method of Crankshaft Balancing

The need of accurately balancing all reciprocating parts of an engine to obtain efficiency and endurance is well enough known, and while balance can be obtained by varying tests, what was desired was a method that would be certain and as inexpensive as possible, especially where engines are built in large numbers.

A very ingenious method of dynamically balancing engine crankshafts is used at the plant of the Continental Motors Corp., Detroit, Mich., that is claimed to be extremely efficient and insure results not previously obtainable save with long and comparatively expensive testing. An apparatus has been constructed which utilizes a jet of compressed air impinging against the surfaces of the vanes of a turbine impeller attached to the crankshaft in test, and one of the salient qualities is that the means of obtaining rotation of the shafts does not affect the actual or apparent condition of balance.

The machine includes a pair of stirrups hung on pivot points that supports the crankshaft while being tested. The center line of the shaft is directly beneath the center line of the pivots. Hardened steel anti-friction rolls are fitted in the stirrups and are spaced so that they make

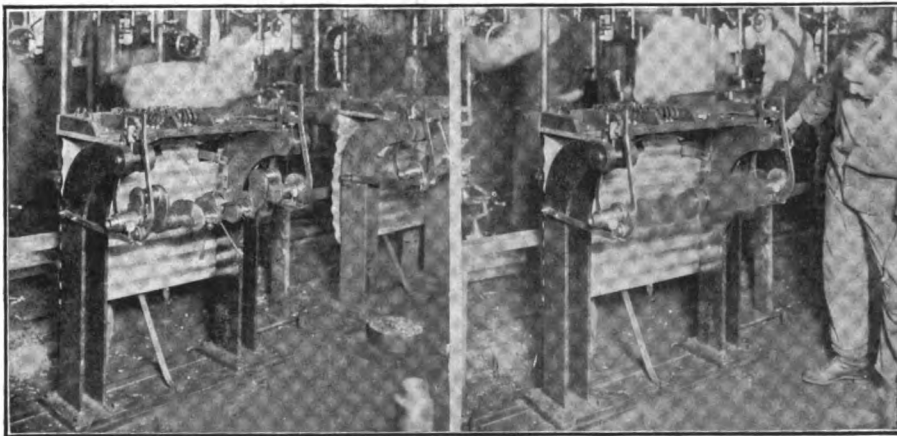

Continental dynamic balancing machine. At left, crankshaft ready for testing; at right, shaft revolving under pressure of pneumatic blast

contact with the journal at either end of the shaft. The turbine wheel, which has six blades, is made fast to the center main bearing of the shaft. A micrometer dial mounted on an independent support makes contact with the shaft at either end. When the shaft is revolved the vibrations are indicated at either end by the readings of the dial of the gauge.

The turbine wheel is 18 in. diameter and each blade is 1.56 in. diameter. The nozzle of the air jet has a deflector and is so located that the current of air is projected horizontally, the orifice being at a line tangent with the highest point of the impeller blades and about 3 in. back of the center line. One will note from the accompanying illustration that because of the pivot support the shaft may swing laterally and longitudinally.

In making test the crankshaft is revolved to a certain speed following the opening of the air valve, the indicators showing if it is unbalanced and variance from zero on the dials of the gauges indicates the values of the unbalanced masses in the shaft. The tester stops the shaft and small balancing weights, attached to spring clips, are snapped over the crank pins opposed to the unbalanced section. The shaft is turned again, the indicating dials

showing the crank pins on which additional weights must be placed to bring the shaft to balance. The spring clips are fitted with steel weights of the same diameter, but different lengths, each carefully calibrated.

When the shaft is nicely balanced the crank pins may have each several weights clipped on them. It is then passed on to another mechanic, who removes the metal indicated by the algebraic total of the calibrated weights. When the metal has been removed according to the indication it is returned to the testing machine for checking and possibly for correction. The results from the changes made can be determined with great accuracy and certainty. Statement is made that the manner of balancing is such that the shaft will turn freely about its axis, but being influenced by mechanical means of rotation, and as it is not held solidly in any position, every factor that would affect the condition of balance is eliminated.

### Failure of the Carburizing Process

The carburizing or cementation process of adding carbon to iron or ferrous alloys is so ancient that its origin cannot be traced. Metal workers for many centuries made good steel by this process, but they did not know that it was the carbon they added to the metal that gave the desired results. Although any of the new alloy steels, properly worked and heat-treated, will give better results than carburized steel, the latter is still much used in the manufacture of some important machine parts, especially in the automobile industry. Low-carbon steel can be machined more readily than high-carbon steel, and this is one of the reasons why the carburizing process has remained, but the principal argument advanced in favor of carburized parts is that they have a hard outer surface that will resist wear to the greatest degree and a tough center that will prevent berakage. The value of these properties, however, is less than might

be expected.

The steels containing from 0.12 to 0.18 per cent carbon, which are generally used for carburized parts that contain approximately 1 per cent carbon in the outer shell, seldom have an elastic limit of more than 40,000 lbs. per sq. in., and this cannot be increased much more than 5,000 lbs. by any heat treatment. If steel with a high enough carbon content to give the best wearing surface is used, the elastic limit can be raised to more than 100,000 lbs. per sq. in. In the early days of the bicycle, ball and roller bearings first came into general use. Then the cups, cones, races, and even the balls and rollers, were carburized. Manufacturers soon learned, however, that the hard outer shells of the balls would compress against the soft centers and cause them to deform; then the bearings soon failed. Many of the balls would also break and crack between the hard outer shell and the soft core, causing the shell to peel off. When the manufacturers resorted to a high-carbon steel and gave the balls a uniform hardness clear to the center, they found that a given size ball would carry a much larger load. Later chromium steel was found best for this purpose. At present high grade ball bearings outwear automobiles, carrying more than twice the load

they bore in the bicycle days.—E. F. Lake, before Steel-Treating Research Club of Detroit.

### Future English Demand for Electric Vehicles

"It is probable that after the war there will be a favorable opportunity in England for the sale of electrically-propelled vehicles," according to Consul E. Haldeman Dennison, Birmingham. "American manufacturers," he says, "would do well to look to this field and be prepared when normal times return to get a fair share of the trade. In the past this type of car failed to obtain much popularity, but the scarcity and high price of gasoline and the difficulty of obtaining any of the ordinary liquid fuels have caused a change.

"Many persons are convinced that the price of gasoline will remain high even after hostilities cease, and in fact may never again be as low as in prewar times. It is true that coal gas as a substitute for gasoline has been largely employed by many motorists, but for various reasons, especially on account of the space that it occupies, only a small proportion have adopted it as a way out of the gasoline difficulty. Already the use of electric commercial cars has begun to show an increase, although they are difficult to obtain under present conditions.

"Several municipalities have been experimenting with heavy electric vehicles and obtained satisfactory results. They have been found to be especially suitable for such work as town scavenging.

"A heavy car which runs between the towns of Smethwick, Dudley, and Kidderminster in this district is supplied with electrical energy at a low cost. Birmingham is well situated from an electric-vehicle point of view. Not only is current cheap, but within a 50-mile radius of the city there are 22 charging stations, apart from the seven stations within the city."

### Ford Co. Must Pay \$19,275,385 Dividend

The Ford Motor Car Co. must declare a dividend of \$19,275,385 in the next 30 days. This is one of the principal provisions of the decree in the Dodge-Ford suit which was handed down at Detroit, December 5, by Judge Hosmer.

The original opinion asserted that one-half of the Ford Motor Co. profits on hand July 31, 1916, should be distributed to the stockholders. The decree also announces that the Ford company cannot conduct a smelting business under its charter rights. For this reason the River Rouge blast furnaces project has been blocked, and the money so far expended by the company must be returned to the Ford Motor Co., as well as any other money spent in the liabilities incurred.

An interesting part of the decision is that the costs are placed on the individual defendants. Henry Ford, Edsel B. Ford, Frank L. Klingensmith and Horace H. Rackham will pay the court expenses and not the Ford Motor Car Co.

### John J. Arnold Falls Under Train

Those who attended the Annual Convention of the C. B. N. A. at Chicago and heard the excellent address delivered by John J. Arnold, a banker of that city, will regret to learn of his misfortune as explained in the following taken from a Chicago paper of October 26.

"John J. Arnold, vice-president of the First National

Bank, fell under a Northwestern passenger train at River Forest late last night and both feet were so mangled they had to be amputated. Mr. Arnold was smoking and did not realize the train from Chicago had reached his home station until it was pulling out. He hurried to the door and leaped off. It was raining and he slipped and fell and both feet went under the wheels. As the train went on Mr. Arnold was left helpless in the rain and darkness. He remained conscious and called for help. A passerby heard his cries and summoned aid. Dr. C. A. Griffith bound up the crushed limbs and took him to the Oak Park Hospital, where amputation took place. The banker lives at 341 North Keystone avenue, River Forrest, and friends feared to inform his wife and three daughters of the accident. Until three years ago the family lived in Oak Park."

### Wheel Makers Organize For War Service

Organization of a war service committee to co-operate with the Council of National Defense was completed by the wheel manufacturers of the United States at a meeting held in Pittsburgh recently. The committee will devise ways and means of making the large number of wheels required by the army and navy in the shortest possible time. The problem faced by the wheel makers is enormous, according to H. A. Long, of Chicago, who presided at the meeting, as the Ordnance Department requires wheels which, it is estimated, will cost \$10,000,000, and another \$10,000,000 worth of wheels is required by the Quartermaster's Department, while it requires four or five months to prepare the wood for a wheel. The committee named at the meeting includes T. A. White, St. Marys, O.; E. H. Archibald, Lawrence, Mass.; H. F. Harper, Lansing, Mich.; O. B. Bannister, Muncie, Ind., and O. W. Mott, Jackson, Mich.

### The Liberty Motor

The recently designed "Liberty" motor is shown by tests to be an especially efficient engine, and it will be used on all U. S. airplanes and motor trucks; the twelve-cylinder engine has surpassed the expectations of its designers. While this motor will be made with four, six, eight and twelve cylinders, the design allows the maximum interchangeability of parts; thus the valves, camshaft drive, pistons, single cylinders, and many other parts can be used on any of the four models. A twelve-cylinder engine can be made up from eight-cylinder parts with the addition of the extra cylinders, etc., and the crankcase and crankshaft. In the same way a six-cylinder engine can be made up from four-cylinder parts with ease. Although this motor has been developed largely by two engineers, one connected with the automobile industry and the other with aviation, it is a combination of the best features of engine design, both American and foreign. It has been so designed that it can be manufactured cheaply in great quantities, and differs from the best foreign engines in the elimination of the great amount of hand work the latter require.

### N. A. D. A. to Meet During Show

Among the conventions of show time in New York City next January will be a meeting of the board of directors of the National Automobile Dealers' Association. They will convene with the vice-president of the eastern states, and have selected January 7 and 8 as the dates.



# A Three-wheel Tractor Novelty

A new type of tractor has just been brought to a manufacturing stage by the Highway Tractor Co., of Indianapolis, Ind. It is three-wheeled, the single front wheel of which serves both as driving and steering wheel and the rear end of which, supported by two wheels, connects to the front end of the trailer by a simple fifth wheel mechanism. All of the wheels are rubber tired, and the tractor is designed for an operating speed of 10 miles per hour.

The accompanying illustrations show some of the features of this unit. It is intended for use with a semi-trailer body having a load capacity of from three to five tons, and approximately a third of the weight is carried on the tractor. The tractor has a dead rear axle on two wheels, and a frame that is carried on this axle and on a single wheel mounted in a yoke in the forward end of the frame. The entire power plant and the cab are so built that they can be pivoted on the front wheel, and in any position the machine can be driven forward or backward or turned in the length of the semi-trailer.

It is claimed that the tractor is so simple that cost of maintenance is mini-

over part of its width so as to form a grease reservoir to insure positive lubrication. The steering ring is carried upon the front axle through the intermediary of a set of coiled springs on each side of the wheel. Each set comprises three springs, two supporting springs above the axle box and one recoil spring below same. The springs are set in recesses formed in the axle box, and a strap iron yoke on the frame rests directly upon them, being held from lateral displacement by means of bolts adapted to slide in lugs formed on the axle boxes. As the driving wheel revolves on the axle, the latter is stationary and is secured in the boxes by set screws.

The power plant of the tractor is a Continental engine having four cylinders with bore of  $3\frac{3}{4}$  in. and stroke of 5 in., that is rated at 22.50 horsepower by the S. A. E. formula. The engine is a standard type and because of

the slow speed of the tractor it is cooled by a circulation of water forced through a cellular type radiator and the cylinder jackets. The engine is equipped with a high-tension magneto and an automatic float feed carbureter. The clutch

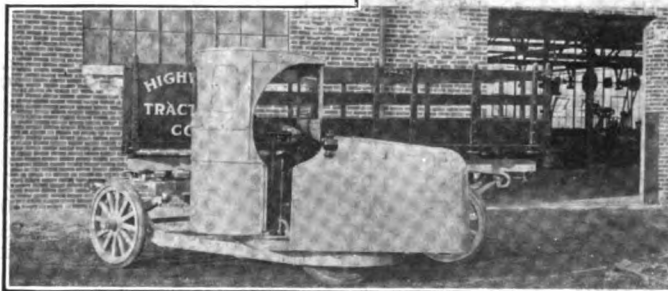

Above, tractor cab swung at right angles to allow traffic to pass ahead of it. Left, turning trailer in exact length of wheel-base of the semi-trailer. Right, cab and power plant reversed to run backward pushing the semi-trailer

mized to a point much below that of the conventional type, the cost of tires alone making a material reduction because the driving is done with a single wheel. As several of the machines have been in use for more than a year statement is made that all of the qualities claimed have been fully realized.

By means of a ball and socket type of fifth wheel mounted over the rear wheels, the Trucktor can be attached to any type of semi-trailer. An arrangement of springs in the connection takes up shocks in starting and stopping. The construction of the fifth wheel is such that the trailer can be connected and disconnected in a moment's time. There is no limit to the range through which the front wheel with the power plant and driver's cab can be turned. If necessary, it may be turned half way around and push the trailer instead of pulling it.

All of the parts of the power plant are mounted on a heavy cast-iron ring, which is turned off on its circumference and placed in a circular groove formed in the frame of the tractor. The circumference of the ring is recessed

is a Borg & Beck single dry plate construction, fully enclosed. The transmission gearset is a special design, having two forward speed ratios and reverse. This is built with gears having very wide faces to insure strength. The drive from the countershaft is by a roller type chain, and the final drive is by an internal gear on the single front wheel that is thoroughly enclosed from dust and water.

The driving wheel is very heavily constructed and it is 34 in. diameter and is shod with an 8 in. solid tire of the pressed-on type. The dead rear axle is fitted with wood artillery type wheels with 36x4 in. solid rubber tires. On this is a set of semi-elliptic springs carrying a rectangular frame on which is the lower section of the turntable of the fifth wheel that carries the semi-trailer body. The rear end of the tractor frame is supported by the springs and the fifth wheel frame and is dropped sharply to a point below the rear axle and is then carried forward and underslung at the forward end from the single front wheel. This makes the center of gravity very low and the ground

clearance is apparently small, but it is approximately the average of vehicle designed for highway haulage. On the chassis frame is the turntable of the cab. As the tractor is carried on three wheels it is not subjected to the same influences that cause distortion of the frames of four-wheeled vehicles, and as the speed is limited there is not

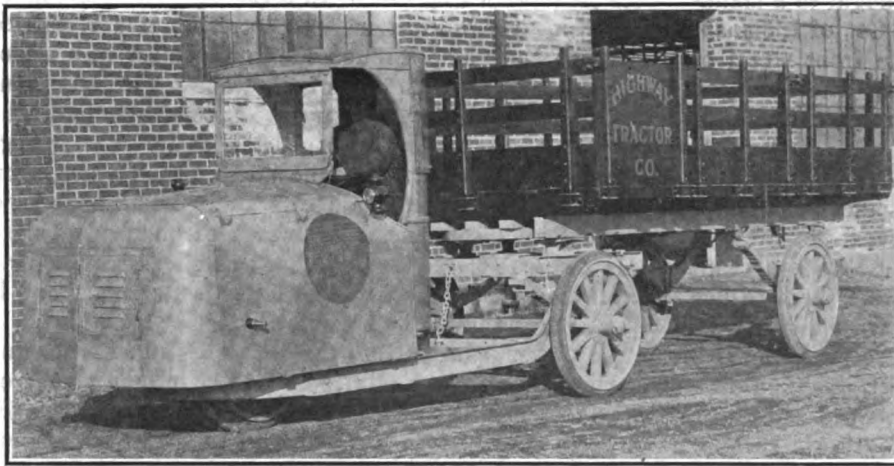

Truكتور coupled to a 6,000 lb. semi-trailer unit on rubber tired wheels, ready for driving straight ahead

the same influences that cause deterioration with machines that are faster.

The turntable that carries the semi-trailer is a ball and socket type that is so constructed that it can be coupled or uncoupled in a very short time by lifting or lowering the body with jacks. The design is such that the fifth wheel can be readily adapted to any standard type wagon or cart. For heavy duty, however, the company advises that the semi-trailers be equipped with rubber tires of

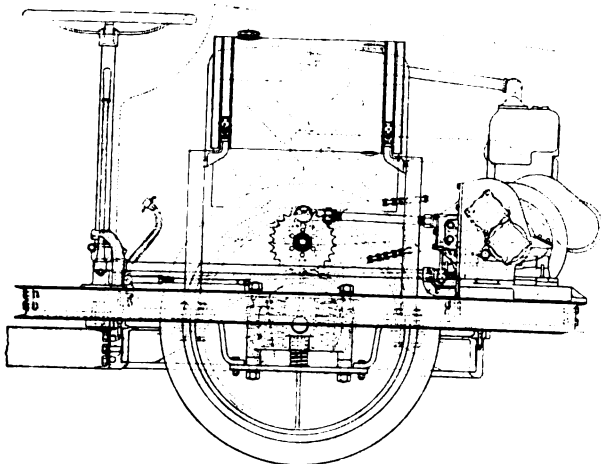

General layout of Truكتور power plant, transmission and steering mechanism

ample size. The price of the Truكتور, with full equipment for coupling semi-trailers, is \$1,750 f.o.b. Indianapolis, Ind.

The Highway Tractor Co. is composed of men well known in the automotive industry. Chas. G. McCutchen is president; Carl G. Fischer, vice-president; Jas. A. Allison, treasurer, and Henry F. Campbell, secretary.

Devise some way of interesting your clerks in reading the trade journals and you will find them growing in value each month.

### Jersey Truck Regulating Law Modified

The new act regulating the use of commercial motor vehicles in New Jersey, which was to go into effect January 1, 1918, and which was regarded as over-severe for motor trucks, has been modified.

Under the new law the speeds were reduced to twelve and ten miles per hour for three and five-ton trucks. This prohibition is removed and the present law left in effect.

Under the new law it would also be unlawful to carry more than two-thirds of the combined weight of vehicle and load on the rear wheels. All existing equipment is now exempt from this provision, though it is not clear how it will affect new equipment after January 1.

Study of the allowable weights to be carried on tires indicates, however, that with normal loading new trucks as at present designed will qualify under the section.

For example, a five-ton truck, loaded and weighing about 21,000 pounds, with a 40 in. diameter wheel, equipped with 6 in. dual tires, can carry on each rear wheel 7,562 pounds, or a total weight on both rear wheels of 15,124 pounds. The total allowable weight would then be 22,686 pounds, which is sufficient.

The allowable weight per inch of tire is increased 10 per cent, or to the weights shown in the following table, giving the gross wheel load in pounds:

Single Inch Tires.	Diameter of Wheel and Carrying Capacity					
	32.	34.	36.	38.	40.	42.
2	621	654	687	726	759	792
2½	924	979	1,034	1,089	1,144	1,189
3	1,237	1,309	1,375	1,446	1,512	1,584
3½	1,556	1,639	1,721	1,804	1,886	1,969
4	1,859	1,958	2,062	2,167	2,271	2,370
5	2,575	2,612	2,750	2,887	3,025	3,102
6	3,096	3,267	3,437	3,613	3,784	3,954
7	3,712	3,921	4,125	4,334	4,537	4,746
Double Inch Tires.						
2	1,237	1,307	1,375	1,443	1,512	1,582
2½	1,844	1,952	2,062	2,172	2,282	2,392
3	2,475	2,612	2,750	2,887	3,025	3,162
3½	3,107	3,272	3,437	3,602	3,767	3,932
4	3,712	3,916	4,125	4,334	4,537	4,741
5	4,950	5,225	5,500	5,775	6,050	6,325
6	6,187	6,534	6,875	7,221	7,562	7,909
7	7,425	7,837	8,250	8,662	9,075	9,487

The section requiring governors on trucks is changed so as to exempt all present trucks.

All motor-driven equipment, including trailers and semi-trailers, must have rubber tires.

### Establish Training School for Women

A training school for women has been established by the Packard Motor Car Co., Detroit. They are expected to do work in the carriage division chiefly, in upholstering and trimming jobs. The safety first department has prescribed costumes. The women may wear either loose overalls or bungalow aprons made of khaki or overall material and must wear caps to protect the hair. Most of the young women in the factory, it is stated, prefer not to wear overalls.

## Specifications for Assembly of U. S. Class B Trucks

In conjunction with letting of assembly contracts for the B trucks the Military Truck Production Board has issued the following specifications to winners of the contracts:

1. DESIGN—All trucks and parts thereof furnished under these specifications shall be manufactured to drawings and parts lists furnished by the Military Truck Production Board, Q. M. C.
2. MATERIAL—All material must be as specified on the drawings unless special permission for substitution has been granted by the Supervisor of Inspection, M. T. P. S.
3. In no instance will permission be granted for substitution of an inferior grade of material unless authorized by a change of the drawing.
4. Wherever it is impossible to define the quality or properties of material on the drawing or in specifications the purveyor shall submit samples for the approval of the Supervisor of Inspection.
5. Not only must all materials conform to the drawings in respect to chemical analysis and physical properties, but must be of uniform quality and free from defect.
6. FORGINGS—All forgings shall be free from injurious imperfections, such as excessive die shifts, scale, fins, cold shuts, pock mark, etc. Forgings shall not be painted before inspection by government inspector.
7. CASTINGS—All castings shall be free from injurious defects such as excessive core or flask shifts, sand holes, blow holes, fins, chill cracks, etc. Core holes shall be thoroughly cleansed of sand, chips, nails, etc. Castings shall not be painted before inspection by government inspector.
8. STAMPINGS—All stampings and pressed steel parts must be free from corner cracks, splits, brittle spots, etc. Stampings shall not be painted before inspection by government inspector.
9. WORKMANSHIP—All workmanship must be strictly first class, all machining, heat treating, assembling, painting, etc., to be done thoroughly.
10. MACHINING—All machining must be to limits specified on drawings. It is not intended to hold unnecessarily close limits, but in no instance will permission be granted for a departure that would destroy interchangeability.
11. The finish must be as specified on the drawing.
12. All threads must fit without shake. All threads must be cut according to tolerance and limits specified by Supervisor of Inspection. Not more than three threads shall protrude after nut is tightened down to final seat.
13. All corners which are exposed shall be broken.
14. No welding shall be done after machining. No welding shall be done on highly stressed parts where strength is liable to be impaired thereby.
15. Soldering of aluminum parts permitted after machining if strength will not be impaired thereby.
16. HEAT TREATMENT—All heat treatment to be thoroughly done and checked by frequent tests.
17. Samples of each heat to be tested to ascertain if required properties are being obtained.
18. Heat treating furnaces should maintain an even temperature.
19. The pyrometer equipment should be frequently calibrated.
20. ASSEMBLING—All assembly must be carefully done.
21. No careless or makeshift work will be permitted.
22. All parts must be cleansed of dirt and chips before being assembled.
23. All nuts must be drawn tight without stretching bolt or injuring thread.
24. All cap screws must be drawn tight without stretching or injuring thread.
25. All cotter pins must be in place and properly spread.
26. All lock wires and lock washers must be in place.
27. Where hot riveting is specified it must be done at proper heat and heads must be perfectly formed.
28. TESTS—The purveyor will be called upon to make such tests of finished product as may be necessary to insure free operation and proper performance of function for which part is intended.
29. The purveyor will be called upon to make such physical and chemical tests as will insure adherence to requirements of drawings and proper performance of function of the part.
30. INSPECTION—The production of the standardized military trucks for the U. S. government and all parts thereof shall be open to inspection by officers of the U. S. Army assigned to purveyor's plant for that purpose.
31. Such officers shall have free access at all times to all parts of the purveyor's works in which any work is under way in connection with any parts furnished under these specifications. Such parts in detail and under such process of manufacture shall be subject at all times to approval of inspectors.
32. Communications between purveyor and department shall pass through hands of inspector stationed at purveyor's plant.
33. Purveyor must provide suitable quarters with necessary desks and equipment for inspectors and stenographic aid if found necessary.
34. Purveyor will give access to all gages, tools, and testing machines necessary to the proper inspection work.
35. All necessary working gages, templates, etc., to be furnished by purveyor.
36. Purveyor will furnish chief inspector a list of sub-purveyors, together with quantity of material ordered from each.
37. Inspector shall have access to all work in process in sub-purveyor plants.
38. Purveyor will furnish inspector reports of all tests that purveyor or sub-purveyor may make on material or parts entering into trucks.
39. Purveyor's employes will not interfere with progress of inspection but must co-operate with inspector in every possible way.
40. All parts will be inspected without unnecessary delay and if found to be in all respects as required by specifications shall be received and become property of the United States.
41. Any parts not conforming to specification requirements in material or workmanship may be rejected by inspector at any stage of process of manufacture.
42. Inspector may upon verbal notice suspend work on any part if in his estimation purveyor is not complying with specifications. Inspector will at once communicate with his superior and obtain quick decision on matter.
43. Contractor shall not continue production of parts in question except at his own risk without approval and

consent of inspector. Inspector will not give approval and consent until satisfied that purveyor does and will continue to comply with specifications.

44. Purveyors will equip themselves with such working and inspection gages as are necessary. Gages will be checked either by Bureau of Standards or by inspector with standard gages furnished by Inspection Department, at discretion of the inspector.

45. The purveyor will notify the inspector at his plant when such tests as inspector desires are to take place. This notice shall be given in advance that inspector may personally witness such tests. Purveyor will make systematic report as to progress of all work in his plant which concerns inspector.

46. Purveyor will provide necessary labor or materials in connection with inspection such as crating or uncrating of gages, instruments, etc.

47. Purveyor must have government inspector pass on no less than 10 per cent of finished parts or units before proceeding into the next operation.

48. MARKING—Purveyors shall mark visibly such parts as inspector shall designate with identification mark assigned by Supervisor of Inspection as well as with the part numbers of the piece.

### Truck Makers Receive Class B Contracts

Seventeen truck manufacturers have received contracts from the Military Truck Production Board for the assembly of 10,000 Class B three-ton standardized war trucks, amounting to \$50,000,000. Delivery will begin January 1 and run up to July 1. It is said that the price ranges between \$720 and \$800 per chassis. The government supplies all the parts and components and pays the transportation from the parts maker to the factory doing the assembling. Contracts were awarded as follows:

#### 500 Each

Bethlehem Motors Corp., Allentown, Pa.  
 Brockway Motor Truck Co., Cortland, N. Y.  
 Diamond T Motor Car Co., Chicago, Ill.  
 Garford Motor Truck Co., Lima, O.  
 General Motors Truck Co., Pontiac, Mich.  
 Indiana Truck Co., Marion, Ind.  
 Kelly-Springfield Motor Truck Co., Springfield, O.  
 Kissel Motor Car Co., Hartford, Wis.  
 Packard Motor Car Co., Detroit, Mich.  
 Republic Motor Truck Co., Alma, Mich.  
 Service Motor Truck Co., Wabash, Ind.  
 Sterling Motor Truck Co., Milwaukee, Wis.  
 United States Motor Truck Co., Cincinnati, O.  
 Velie Motors Corp., Moline, Ill.

#### 1,000 Each

Gramm-Bernstein Co., Lima, O.  
 Pierce-Arrow Motor Car Co., Buffalo, N. Y.  
 Selden Motor Vehicle Co., Rochester, N. Y.

### New York Show Decorations

Mural paintings will replace the lattice work and plaster cast of former years in the decorations of the New York Show at the Grand Central Palace, January 5-12. Shields representing the "Flame of Liberty" upholding the flags of the allied nations will be used to decorate the pillars on the main floor and the windows will be curtained with materials of a tapestry-like appearance.

### Wheel Track Testing Gauge

A gauge for testing the tracking of wheels has been invented in England by the Wood-Milne, Ltd., Manchester. The appliance, although telescopic, packing into small space as shown in the illustration, and of light weight, thus complying with the requirements of portability, is intended essentially for garages. The main section (A) of steel tube, about  $\frac{3}{4}$  in. diameter and 36 in. long, is designed to receive an extension sliding within, as well as the other sections which are removable. At either end of the main section is a butt which receives the short member (B) at right angles to A, set in position by a simple bayonet joint, and there held firmly by the aid of a thumbscrew. The free end of B has a light-pierced butt, which carries the scribing leg (C), set at right angles to B, but with the point outward. Each member (C) is held in place by a thumbscrew, but the arrangement is such as to permit adjustment to be made.

The diagram illustrates the method of using this tool. The telescopic member (A) is drawn out and made tight,

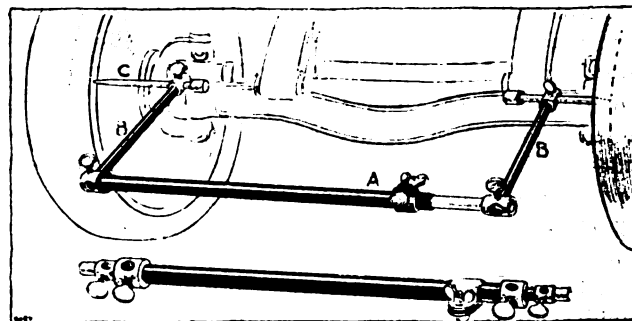

How the wheel track testing gauge is used

the B and C members likewise being brought to position and secured. When extended the points of the two legs (C) should bear against the rim of either wheel, adjustments to this end being made by means of the main member A, or setting either, or both, of the two legs (C) by means of their respective thumbscrews.

By holding the gauge parallel with the axle and level the appliance may be passed up and down along the wheel rim. Should the two points, when the gauge is applied at one part of the rim, bear evenly against either rim, and then upon removal to another section of the rims be either too easy or touch one rim and not the other, obviously the wheel is out of track.

The device is so designed as to allow a wheel rim to be tested up from the most difficult position, such as the engine side of the front wheels, and the live axle of the road wheels, inasmuch as the outer leg can be passed under the obstructions without effort.

### Invents Turbine Gasoline Engine

Bror Stenman, a Worcester, Mass., man, has invented an internal combustion engine, operating on gasoline, that works on the turbine principle. The engine, according to the inventor, will take up 75 per cent less room than the type now in use of similar horsepower.

His model is 8 in. long and 6 in. high, and he claims that an engine of that size when running would develop 10 horsepower. Mr. Stenman is a practical engineer and mechanic and has many valuable and prominent inventions to his credit.

### Jack, Operated From Seat, Lifts Car

A novel jack has been invented in England, which, operated from the seat, can lift the largest car from the ground in a few seconds. It is called the Rapid Mechanical Self-lifting Jack and is permanently attached to the car.

Two different types are being manufactured, one an engine-driven device and the other a mechanical. With the first named the mechanism raising the car is controlled by a lever at the driver's seat. The hand-operated model is operated by means of a winch handle being inserted into a recess under the running board. The last named type is said to be easy to install.

The weight of the car is supported by four ball-ended hinged legs, which are normally horizontal and practically concealed from view. These legs or levers have coupling rods linked with threaded sleeves which are actuated by

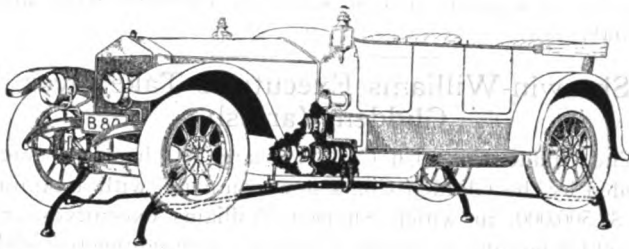

chain as shown in the accompanying sketch. The chain pinion operating the sleeves is actuated by the energy of the engine through the use of the engine clutch shaft. This shaft has a sleeve mounted on roller bearings and carries a small spur pinion which meshes with a larger wheel on an intermediate shaft. The sleeve also embodies a pawl clutch, by means of which the clutch shaft can be locked solid with the sleeve carrying the small pinion.

The lifting mechanism is automatically disconnected when the car is raised the desired or maximum height from the ground. This is obtained by a limit lift rod connected to forks operating dog clutches. In lowering the car the power is taken through the small and large pinions, as when lifting. Two hand-operated jacks are made. One is the design mentioned and the other consists of a type with which each wheel can be raised separately or the entire car raised. When the machine is jacked up it can be moved forward, backward, sideways or turned in its length by means of the ball runners. It is stated that there is sufficient room under the car for inspection, etc., when jacked up. The jacks are made in six different capacities, and while prices have not been definitely fixed on account of the war, these are said to vary from \$100 to \$200.

### The Air-cooled Automobile Engine

"Whatever may be said about the heavier cars," says Autocar, "air-cooling will always possess a special attraction for the designer of light cars. It diminishes weight, it reduces the cost of manufacture, and it simplifies upkeep. Air cooling, as has been repeatedly pointed out, is making great strides, thanks to aviation; cylinder distortion is being eliminated; cooling is being improved by better material and sounder constructional methods, and weight is being reduced in an almost incredible ratio.

"Of all types of air-cooled engine, the radial is possibly the most attractive. It can be mounted at the extreme

nose of the chassis, where it will not be unsightly and where all of its cylinders will get an even cooling blast with a fan on the reverse side if necessary. Its short crank shaft and other constructional details endow it with amazing power-to-weight ratios. Already we have a flat air-cooled twin engine at three pounds per horsepower. The radial engine is extremely shallow, and would allow the car builder an extra two feet of space along the chassis. There is no need for the large number of cylinders used in air propulsion to secure a satisfactory balance. A 20 horsepower 800 pound vehicle is probably practicable. The type is perhaps suited only to comparatively low horsepowers, as the crank shaft center would come too high up if the cylinder were at all large."

### Preparing for New York's Big Auto Show

Splendid progress is being made for the 18th annual National Automobile Show, to be held in Grand Central Palace, New York, January 5 to 12. There will be a larger number of individual exhibits of cars, accessories and parts on the four floors of the big building than ever before and many products will be shown for the first time. In all there will be 86 different makes of cars and 266 accessory displays at the Palace show and a like number will exhibit at the Chicago exhibition, January 26 to February 2.

S. A. Miles, who manages both the New York and Chicago shows, which are held under the auspices of the National Automobile Chamber of Commerce, has been compelled to turn down applications for space from late comers, despite the fact that under the present space arrangements a little more room is available than last year.

An array of more than 300 new, glistening models of automobiles, ranging all the way from tiny runabouts selling for a few hundred dollars to the largest, roomiest limousines costing more than \$5,000 will be shown. Among the exhibitors are several makes of electric cars and steam cars.

The exhibits will include cars meeting every purse, but of necessity due to the increased cost of material and labor, the percentage of low-priced cars will be markedly lower than in 1917. Last year about 10 per cent of the models sold for under \$750. This year just slightly under 6 per cent of the models on the market will sell under this mark. An indication of the price changes is provided by recently compiled statistics, which show that 21.6 per cent of the 1918 models will list for under \$1,000. Last year this price class represented 27.7 per cent of the models. A man desiring to spend between \$1,000 and \$2,000 for a car this year will have 49 per cent of the models on the market to select from, while last year he had 53.6 per cent. Carrying the classification still further to the cars selling for over \$2,000, one finds that the 1917 and 1918 percentages are 18.7 and 29.4, respectively.

### New Swedish Auto Truck

The Aktiegolaget Scania-Vabis, of Malmo, Sweden, has placed on the market an automobile entirely new in construction. It is a truck with a capacity of four tons and is especially intended for drawing other wagons of different kinds. With this object in view it is equipped with driving and steering gear on all four wheels and can be guided from both ends.



### Piston Grinding Fixture

The illustration shows a simple and effective means of holding a piston for grinding. Simply slide into place the loose pin that fits snugly into the wristpin holes of the piston, slide the back-plate onto the base of the piston, then drive the drift until all are bound together. It is then ready to be placed on the centers. The driver is furnished by the bridge part of the back end, which engages a driving pin. To remove the piston, knock out the drift and withdraw the pin. All parts of this fixture should be hardened, except the base. In several concerns where this fixture is in use, from 25 to 35 pistons,  $3\frac{1}{2}$  to

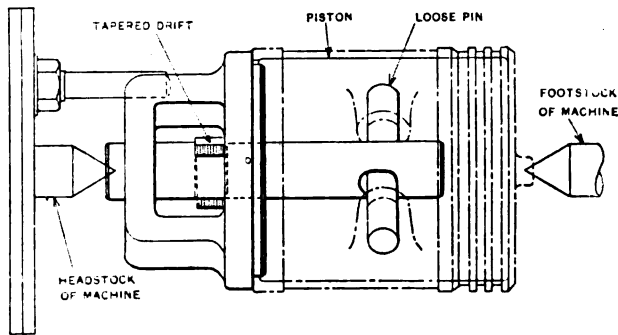

Grinding fixture with mounted piston

$3\frac{3}{8}$  in. diameter, are produced per hour, removing from 0.025 to 0.030 in. stock to 0.001 in. limit, there being three diameters to grind.

The operation is performed by sizing the body over the entire length, which is the largest diameter. This is done by two methods: by feeding the wheel straight in for a full width cut (no traverse), using a wide wheel, or by stroking the work with a 2 in. wheel. Then grind the two bottom rings, the next largest diameter, also with a straight-in cut, and the ring or smallest diameter, also with a straight-in cut, and the piston is finished. Two fixtures are usually used, the operator loading one while the cut is being taken on the piston mounted on the other.—H. W. Dunbar, in Grits and Grinds.

### Another Cog in the Du Pont Wheel

The paint and wood finishing business of the Bridgeport Wood Finishing Co., of Still River, Conn., has been purchased by E. I. du Pont de Nemours & Co. Possession was taken as of December 1, 1917.

The Bridgeport Wood Finishing Co. manufactured a line of paint and wood finishing products for more than 40 years. Its output is widely known to architects, painters and furniture manufacturers throughout this country and abroad.

As is already known to the trade the Du Ponts have entered the American paint field in an important way through their purchase some time ago of the old established firm of Harrison Bros. & Co., Inc., of Philadelphia, which under the name of Harrisons, Inc., is now manufacturing and marketing on a more extensive scale than ever a line of well known paints.

The purchase of the Bridgeport concern makes that company a part of the Du Pont American industries and its future will be watched with considerable interest because of the extensive facilities of the Du Ponts for the manufacture of many chemical raw materials, coupled with their well known efficient producing and selling organization.

### Auto Salon Will Open 1918 Show Season

As heretofore, the automobile show season in this country will open with the annual Automobile Salon in the grand ballroom of the Astor, New York, on January 2. The salon of 1918 will be as big and as brilliant as usual, and will be duplicated on January 28 to February 2 in the Elizabethan room of the Congress, Chicago.

The Automobile Salon has the distinction again of being the only exhibition of international character to be held anywhere in the world this season. To be sure, the foreign representation has suffered severely as a result of the war, and only England and Italy remain of the half dozen European nations formerly represented at the annual salons in this country.

The makes of cars to be shown at the New York salon include the Biddle, Brewster, Cunningham, Daniels, Fageol, Fergus, Lancia, Locomobile, Murray, Mercury, Rolls-Royce, Simplex, White and Wolverine. Separate custom coachwork exhibits will be made by Brooks-Ostruk and Rubay.

### Sherwin-Williams Executives Take Over Glidden Varnish

The Glidden Varnish Co., Cleveland, O., has been succeeded by the Glidden Co., a new company, with a capital of \$2,500,000, in which Sherwin-Williams executives are the chief factors, although it is in no way connected with the Sherwin-Williams Co. Adrian D. Joyce, until recently director and general sales manager of the Sherwin-Williams Co., is president of the new company, while O. A. Hasse, formerly paint and varnish sales manager for the Sherwin-Williams Co., is vice-president. R. H. Horsburgh, formerly controller of the Sherwin-Williams Co., is secretary and treasurer.

Members of the Glidden family, including F. A. Glidden, president, have resigned, but the rest of the organization remains intact, the managing ownership only having been affected. The present Glidden plant, covering nearly 17 acres, modernly equipped, is to be expanded.

### Rate on Bearings

On complaint of the Hyatt Roller Bearing Co. against the Delaware, Lackawanna & Western Railway, the Interstate Commerce Commission has ruled that a rating on roller bearings (other than car bolsters), in official classification territory in excess of third class in less than carloads and fourth class in carloads is unreasonable. An order has been issued requiring the defendant to maintain and apply the third and fourth class ratings, respectively, for a period of not less than two years.

### Same Pay for Shorter Day

The Defiance (O.) Machine Works will place its plant on an eight hour basis January 1, but the present rates and the ten hour day, 55 hour per week schedule, will be maintained. However, all overtime beyond eight hours will be paid at the rate of time and a half and each employe who works the full 55 hours each week will be paid a 5 per cent bonus.

Between 1,500 and 1,800 women have taken the place of men in the last few weeks in Cleveland metal working establishments. They are employed largely on drill presses, punching machines and light bench work.

## Paint and Varnish

### Preserving the Youth of the Car

It is of vital concern to the painter that the car be kept young to the longest possible limit. From a purely selfish standpoint it would seem that the reverse should be true: but in the long run the painter profits most through the maximum durability of his work. Durability and good looks in the finish of the car are to be had only from a system of care taking that conserves and preserves the paint and varnish to the full extent of the natural resources of the material. In former issues *The Hub* has urged the necessity of the most painstaking attention to the finish on the part of the car owner, and what was then said may be rightly accepted in connection with what is here urged.

The painter may, of course, let the car go out of the shop without offering any advice to the owner and justify himself on the ground that so far as he is able he has given value received, and that in no possible way can he be held accountable for a careless and inferior method of care taking for the car. This, however, is small satisfaction because eventually he will be the loser. Car owners have long memories, and whatever loss they sustain by reason of wrong treatment applied to the car through lack of information which should logically come from the painter, is mentally charged up to his account. Not only this, but the transaction is circulated broadcast to the sweeping injury of the painter's business. Therefore, taking the situation broad and long, no matter connected with the painting business is quite so important as this very detail of giving freely expert advice covering the care taking of the car during its life of service on the road and in the garage. When this service is rendered, and with a good job of painting and finishing performed, the painter may rest assured of having done his share in contributing to the work of preserving the youth of the car.

Wrong methods of washing do more to destroy the youth of the car before its normal time than almost any other treatment accorded it. Such methods start at the beginning of the life of the finish and thus the car takes on an ancient look in the days of its youth whereas it should appear young to a period well past its prime. As the finish stays young and takes on a rich and fine brilliancy under the approved methods of care taking, the professional standing of the painter gains in prestige.

The use of the hose in washing the car should, generally speaking, be discouraged. Correctly handled, the hose may prove a desirable means to an end, but so little information prevails among car owners and users in regard to the correct way of using this utensil that it is for the inexperienced a most unreliable apparatus for the particular class of work. Unless fully informed in the way of handling the hose it will prove the wiser course to let it completely alone, and instead use a good, soft-wool sponge of sufficient water-carrying capacity to get the work along quickly.

Start at the upper part of the car body, and with the sponge full of water proceed to let the water run freely

down over the surface, soaking up the dirt and mud and other surface accumulations and finally carrying them off by the mere power of water volume. In this manner there is no surface irritation or defacement. When the bulk of the dirt and foreign matter is taken away, again go over the surface with the sponge fully charged with water and gently pressing it wash off the remaining dirt atoms. This is, to be sure, a slower method of washing than that provided by the hose, but it is also a safer one, and productive of better results. If circumstances are such that the use of the hose becomes necessary then as a matter of precaution, if not of safety, a rose or stopper should be attached to the water flooding end of the hose. This will soften the pressure of the stream, and in a measure save the finish from injury. But by either method, the use of the sponge for a final dressing off of the surface is desirable, and even necessary.

Even the wash leather, or chamois skin, can be used to the injury of the finish, as simple as the use of this skin appears to be. Never bear heavily on the leather in drying off the surface, for by so doing the real purpose of the work is defeated. Wipe the finish lightly in order to catch away the lint and flocculent matter, and leave the surface in a fresh, clean condition, with the moisture drops to evaporate and disappear in nature's own way.

This, briefly, is the correct way of washing the car. It is at first thought apparently anybody's job, but like many other processes there is an important know how figuring in the work, making it a success or failure. Never let mud dry on the car is also good advice to give the car owner. Nor should the car be washed in the sun or in the extreme cold. Use water having a gentle warmth, except in the warm months, and on freshly applied varnish, when cold water serves to harden the varnish.

Keep the upholstery well brushed and renovated. This may seem like superfluous advice for the painter to offer, but more and more he is being looked to for the right attention to the finish on the interior of the car, including the upholstery furnishings. Among the upholstering materials leather substitutes are at the present time being largely employed. Renovating and renewing the finish on the car interior furnishings, when the painting repairs are being applied, comes naturally as a part of the painter's business. Leather and leather substitutes become in time worn at the folds and edges, and this condition will need a stain to restore at least a semblance of the former color and quality of the material. Follow this treatment with whatever renovating methods and processes may appear suited to the condition of the work.

On the interior of the car the vacuum cleaner will be found almost an invaluable agency for licking up all forms of dirt and dust. All carpets, coverings, and furnishings of every kind may be quickly and completely cleaned by the vacuum method. Such attentions on the part of the painter enable him to turn out the car harmoniously finished throughout. It adds to his reputation as a thorough-going mechanic and business man. Moreover, it helps to preserve the youth of the car.

## Making the Paint Shop Pay During the Winter Months

Years ago how to make the paint shop pay formed a topic which numerous writers exploited exhaustively in the trade press, only to discover later on that the paint shop when handled in the same manner that any other legitimate business is handled, not only paid, but in many cases furnished a handsome profit, as it may well be expected to do. Since the discovery has been recognized as an actual fact we have heard little concerning this phase of the situation. However, to make the paint shop pay during the winter months is not an easy matter—that is, to make it pay the ratio of profit coming to it during, say, nine months of the year.

If the paint shop is located in a well established garage the problem for December, January and February is, of course, greatly simplified, because many car owners having vehicles stored in the garage, or maintained there, will readily consent to having the annual painting repairs applied to the car during its winter sojourn, and while it will have plenty of time to cure out and harden. When the paint shop is located apart from the garage it will prove more difficult to get the cars into the shop; but a little extra canvassing on the part of the shop owner will suffice, as a rule, to fetch enough cars in to keep all hands busy. If the shop is large enough to store the cars for a while after finishing, so much the better, for not a few cars may be obtained with that understanding. Then by going after and returning some of the car equipment additional painting may be obtained; some car owners like to be patronized to some such extent. In any event, the main thing is to get the cars in upon some mutually satisfactory basis.

The good roads will prove when it comes to a case of taking winter contracts a splendid benefit to the painter, because moving to and from the shop then becomes a simple matter of getting right out after the cars at all times and seasons. At the winter season it may be possible to take some classes of work at a little discount, as compared with the summer schedule of prices. This inducement, even though it is but nominal, is generally attractive enough to the car owner to get his business at a date when he otherwise would for some time delay having his equipment painted. At this season the shop owner may find it of big advantage to give his business some unusual publicity to keep it in the public eye, to make it talked about. Then make the work live up to the claims made for it. Thus make the paint shop pay.

## Lead Poisoning From Use of Air Brush

As a result of the use of the air brush in applying coats of paint to chassis and bodies, there have been quite a number of cases of lead poisoning in the automobile industry.

The Packard Motor Car Co. formerly put a priming coat on under a large hood, which was supposed to carry away the fumes and lead. However, one man who was put on a job began to lose weight after having been at it for a little over two weeks. At the hospital it was found that he suffered from lead poisoning. The spraying method was therefore discarded and the priming coat was again put on with the brush. As the entire chassis and body are sprayed it is not possible to cover the men up completely, as they could then not get around the car. Finally a

helmet was adopted, as well as a respirator, the device being built right down to the floor in a separate room. The old exhaust system was torn out and another of five times the capacity installed. This system has been in operation for only a few months so it cannot be said that lead poisoning has been eliminated with absolute certainty.

Cases of poisoning among the men employed in the painting department of the Gilbert & Barker Mfg. Co., who also spray their paint, were brought to the attention of the company by the state factory inspector who reported it to the Bureau of Labor. An expert on skin diseases was engaged and five cases were given to him. The doctor was unable to ascertain whether these were cases of lead, zinc or turpentine poisoning, but Mr. Shirley, who reported the matter to the Safety Congress, was of the opinion that they were turpentine poisoning, as it had been difficult to get first class turpentine and second class material was used. The men affected were transferred from the paint shop to the assembly machine shop and other departments, and were given periodical treatment by the expert to eliminate the rash which had broken out on their arms where their sleeves rolled up. Some of the men had their entire bodies covered with this rash. They could not sleep at night and consequently were of little use to the company during the day. By transferring the men to other departments and having the specialist treat them they were cured and went back to the paint shop. They have not been back long enough to tell whether they are immune against further attacks. Every Saturday morning they are examined by the physician and the company hopes to collect some valuable information regarding poisoning and skin diseases contracted in paint shops.

## \$75,550,000 for Armored Cars

In his estimates of appropriations required by the government during the fiscal year ending June 30, 1919, Secretary of the Treasury McAdoo has asked for an appropriation of \$75,550,000 for the purchase, manufacture, test, repair and maintenance of armored motor cars. It is to remain available until the end of the fiscal year 1920.

## Johnson's Promotion in Laidlaw Co.

James H. Johnson, who so ably handled the affairs of the Detroit office of the Laidlaw Co., Inc., has been made a vice-president of the company, and is now located in New York City. Johnson will be followed in Detroit by W. A. Sweetland, who has been in charge of Laidlaw sales in Cleveland.

## Cately & Ettling to Quit Business

Mrs. A. M. Cately, of Cately & Ettling, Cortland, N. Y., manufacturers of buggy top springs and levers and roller chafe irons, announces that she is about to close out the business. Mrs. Ettling has always been a familiar figure at the annual C. B. N. A. conventions, having attended 28 consecutive meetings of the organization.

## Ford Steel Plant a Mile Long

The Ford steel plant on the River Rouge near Detroit measures a mile from one end to the other by speedometer reading. By 1920 it is expected that the plant will be in full operation.

### Movable Platform for Spring Assembling

The Detroit Steel Products Co., Detroit, recently installed a movable assembling and inspection platform in its spring factory. Aside from cutting the number of men employed for this work almost in two, from 45 to 25, the company states that errors in assembling are minimized, the production is speeded up and the assembling of the spring leaves and their inspection before incorporation in the completed spring simplified. This platform is another of the special mechanisms developed by the company.

The platform, which has a daily capacity of approximately 40 tons of springs, enables the various operations entering into the assembling and inspection of springs for motor cars and trucks to be handled easily. There are in all 12 steps in the process of assembling and inspecting a spring. These are facing the long plate, reaming the eye, grinding the spring ends, polishing the back and plates of the springs, riveting the clips, lubricating and assembling the leaves, inspecting for fit and to see that the spring

ties than any other country in South America as a market for automotive vehicles. Previous to 1911, cars which were imported into Argentina came largely from Europe. The numbers imported during the last six years were: 1911, 2,461; 1912, 4,281; 1913, 5,115; 1914, 2,185; 1915, 1,847; 1916, 5,929. The importation of European automobiles reached its zenith in 1911, the year of the crisis. Since that time sales of the expensive European car have fallen, and today there are unsold cars that dealers have been carrying for years.

For 10 or 15 years previous to the war automobiles in Argentina were confined chiefly to the cities, such as Buenos Aires, Rosario, Bahia Blanca, Mendoza, Cordoba, La Plata, Santa Fe, and Tucuman. The European cars sold almost exclusively in the cities. The American car today is selling almost exclusively in the country. European cars were largely of the expensive types in all the best makes. They were owned by the wealthy business men as well as the wealthy estancieros (farmers), who

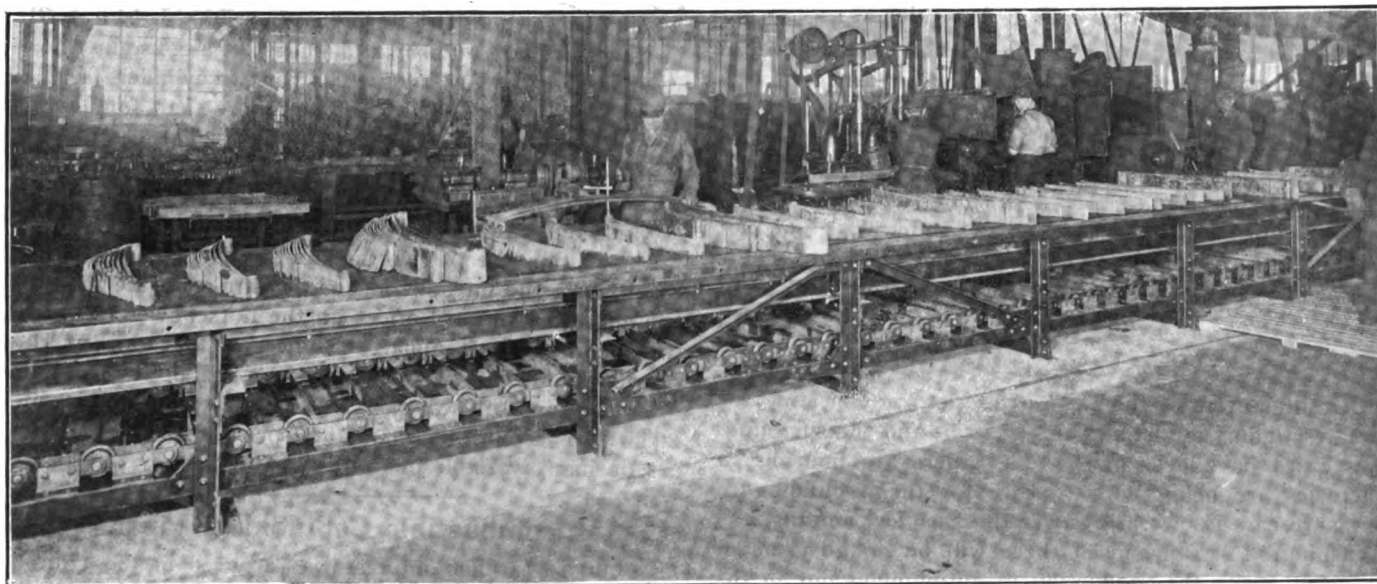

Movable assembly and inspection platform installed in the spring factory of the Detroit Steel Products Co., showing centrally the grinding of the spring ends, the third of 12 successive operations all performed on the platform

leaves are all turned in the proper direction, the bulldozer and capacity tests, the placing and riveting of the clip bolts, and the final inspection.

The first three stages are brought out in the illustration. At the right the first operation, that of grinding the sides of the curved loop at the ends to make it square and smooth, or, as it is termed, facing the long plate, is being performed. The reaming of the eye is next shown, this calling for an accuracy of 0.001 in. and perfect alignment with the backs. At the extreme right the ends of the springs are being ground.

### Argentine Market for Motor Vehicles

A report on the Argentine market for motor vehicles has been published by the Bureau of Foreign and Domestic Commerce as Miscellaneous Series No. 62. It was prepared by David Beecroft as an appendix to the report of the party that was sent to Argentina by the Latin American Return Visit Committee. It is issued by the bureau because it deals with a subject of great interest to American manufacturers who are concerned with foreign trade.

The writer finds that Argentina offers greater possibili-

spent much of their time in the cities. The country districts, being practically without improved roads, were not suitable for such automobiles. In fact, it was very rare that a resident of Buenos Aires would attempt to drive even to Rosario, a distance of 175 miles. In dry weather such a drive might be possible, but it would be very unpleasant because of the trail-like roads and the clouds of dust. In wet weather the trip is impossible, for the heavy cars could not make any progress over the black-soil roads. With few exceptions, the expensive European automobile was a city vehicle for the wealthy classes.

### Advent of the American Car

The advent of the American car in quantities introduced a new order of motor. The cheap American car did not appeal to the wealthy citizens. Selling activities formerly confined to the cities were transferred to the country. Pioneer American salesmen started across the pampas with their demonstrating automobiles. They proved that the American car is a practical machine for those endless level stretches of fertile farming land. They proved that the virgin trails over which 10 to 20 horses slowly pulled the huge farm cart with its 6 to 12 ft. wheels could be

traveled by the American car. The salesman demonstrated to the estanciero. At first he was opposed to the car. It was impractical in the country; it did not coincide with his conceptions of a car; and it would not last. A few demonstrations proved otherwise. The car was driven over every part of the estancia. It was sold to the estanciero and to his family as well. This selling campaign spread from one part of the pampas to another until it permeated every part of the cultivated country from the Atlantic to the Andes.

It is not surprising that with such an introduction during 1914 and 1915, 80 to 90 per cent of the American automobiles sold in Argentina today go to the wealthy farmers. These cars are receiving severe service. They are not given that delicate attention that the city car receives. Expert repairmen are scarce through the Argentine camp, and only crude repairs on the gasoline engine are made. Notwithstanding these handicaps the sales are increasing rapidly in spite of poor crop conditions and poor shipping facilities to Europe. There are today between 30,000 and 40,000 cars in Argentina.

The field of the motor truck in Argentina has not been developed to any extent and the truck movement is lagging far behind the car movement. There is a good selling field for trucks in the city of Buenos Aires and a limited selling field in some of the other cities such as Rosario, Bahia Blanca, Mendoza, and Cordoba. In the smaller cities street pavements are generally good, but wide streets are not so common as in Buenos Aires. There is a very big selling field with the estancieros.

### Very Busy at Detroit

Manufacturers of the Detroit district are expecting the greatest industrial activity that Detroit and the surrounding cities have ever had. War orders are pouring in, factories are being built to care for them, building of pleasure cars is increasing over the past few months, and Washington has promised there will be no government interference in the production of automobiles nor in the use of freight cars for their transportation. Factories are still going through the period of adjustment prior to the making of munitions. One of the largest automobile firms in Detroit reports the heaviest business in its history in pleasure cars. The Ford Motor Co. is increasing its production of material for the government, and its factory, which employs from 30,000 to 40,000 men in normal times, is expected to house one of the greatest war industries of the country. Dodge Bros. have increased their capitalization from \$6,000,000 to \$10,000,000, the increase to partly take care of the new factory being built for ordnance work. The Packard Motor Car Co. is increasing its production of war trucks and Liberty motors. The new Lincoln Motor Co., Detroit, is rapidly completing its factory for the making of Liberty motors. The Cadillac Motor Co. is working on its second large war order, but not curtailing the production of pleasure cars.

Purchases of real estate by large manufacturers show that the future is being anticipated. The Detroit Shipbuilding Works and the American Shipbuilding Co. are working to capacity, although handicapped by the lack of skilled labor. The government has taken so many skilled mechanics from Detroit factories that there is general complaint of the dearth of skilled men. Unskilled labor at present surfeits the demand, but the training of new

men for expert work is progressing rapidly. Transportation is much better than at this time last year, and money more obtainable than for some time.

### French Official Formula for Rating Auto Engines

The question of a formula which will give some fairly approximate idea or reasonable basis of comparison of the power capacity of an internal combustion engine has long been of interest. In England it is well known that for taxation purposes the government adopts the R.A.C. formula,  $D^2 \times N \div 2.5$ , D being the cylinder diameter in inches and N the number of cylinders. The drawback to this formula is that no regard is paid to the question of the effect of varying piston stroke on the power development. According to Cycle and Automobile Industries, in France a new formula has been issued by the Ministry of Public Works, and is now being employed by the Service des Mines for determining the amount of annual tax payable by car owners.

The new formula is  $H.P. = N \times K \times D^2 \times L \times n \div 60$ ; in which N is the number of cylinder; K a constant whose value is, for single cylinders 0.002, for two cylinders 0.00017, for four cylinders 0.00015, and for more than four cylinders 0.00013; D the bore in centimetres, L the stroke in centimetres, and n the number of revolutions for the maximum speed of the car on the level. While on the basis of equal bore and stroke the French formula gives a lower rating in the case of two and four-cylinder engines than the British, the introduction of the stroke in the formula has a marked upward effect on the horsepower rating of the engines. It is apparent, however, that one of the drawbacks of the new French formula will be the problem of deciding as to the number of engine revolutions to be taken into account, the maximum speed of the car depending on many variable quantities.—Autocar.

### Incombustible Celluloid in Japan

About a year ago interest was aroused in the United States by the announcement that a professor in one of the Japanese universities has invented a successful incombustible substitute for celluloid, to be manufactured from soya bean cake. The new product has been given the trade name of "Satolite," derived from the name of the inventor, Prof. S. Sato, and a company for its manufacture has been started with a capital of 2,000,000 yen (\$1,000,000). Satolite is a galalith made of the glucine of soya bean, coagulated by formaline. It is said to be produced much more cheaply than ordinary celluloid, and to have several advantages for industrial use not possessed by the latter. The factory is to be built in the Mukojima district in Tokyo, and the actual production will begin this autumn.

### N. Y. Postoffice Will Operate Trucks

The United States will own and operate mail trucks in New York City, 150 trucks have been ordered and a garage has been opened on West 37th street between Eighth and Ninth avenues. The service will be completely motorized January 1, when the present contract for transporting mails will terminate.

This is no experiment, as government-owned trucks have been successfully operated in Chicago, Philadelphia, Boston and other cities two or three years.



# Vehicle Industry News in Brief

## Truck Builders

**Triangle Motor Truck Co.**, Clinton, Mich., has begun work on its new plant, and expects to be making trucks early in 1918.

**General Vehicle Co.**, Long Island City, will continue the manufacture of electric trucks, notwithstanding that a considerable portion of the local plant will be devoted to other work.

**Columbia Motor Truck and Trailer Co.**, Pontiac, Mich., has received a \$975,000 contract for two-ton Columbia trucks for export. Deliveries are to be made over a period of three years.

**Stewart Motor Corp.**, manufacturer of motor trucks, is building an addition, 51 x 110 ft., to its plant at East Delavan avenue and the New York Central Railroad Belt Line, Buffalo, N. Y.

**Moreland Truck Co.**, Los Angeles, manufacturer of motor trucks, will build a one-story addition, 40 x 100 ft., to its foundry at its new plant now in course of construction at Burbank.

**Barger Truck Co.**, Indianapolis, has been incorporated with \$50,000 capital stock to manufacture four-wheel-drive automobile trucks. The directors are Henry W. and O. Barger and Walter Brewer.

**Republic Motor Truck Co.**, Alma, Mich., will transfer its motor and transmission assembly department to the new factory until now nearing completion. The building, which will also contain a blacksmith shop, is 240 x 112 ft.

**United Motors Co.**, Grand Rapids, Mich., shipped 15 trucks to the government seven days after receiving the order. The order included both 2 and 3½-ton trucks, and they were shipped to the aviation camps at Rantoul, Ill., and San Antonio, Tex.

**United States Motor Truck Co.**, Cincinnati, O., is now producing 150 trucks daily. Provision has been made for quickly doubling the plant's capacity by building additions to hold the stores of material which the company has accumulated, and throwing an entire extra floor into the assembling department.

**Saxon Motor Car Corp.**, Detroit, is delivering to dealers a 500 lb. light delivery car built on its six-cylinder chassis. Either panel body or open body with curtains is supplied. The chassis has been made slightly heavier and strengthened where necessary to make it suitable for the additional load. The price is \$850.

**Rowe Motor Mfg. Co.**, Downingtown, Pa., manufacturer of motor trucks, has purchased a five-acre tract along the Pennsylvania Railroad, Lancaster, Pa., and contemplates the erection of a new plant which is expected to be ready for occupancy March 1. It is said that the Downingtown plant will be moved to the new location.

**Stegeman Motor Car Co.**, 606 Linus street, Milwaukee, which has been in process of reorganization for several

weeks, will be succeeded by the Hercules Motor Truck Co., with a capital stock of \$100,000. No details of future plans are available. Arthur Davidson, of the Harley-Davidson Motor Co., Milwaukee, is a stockholder. Lynn S. Pease, 1301 Majestic Building, is attorney.

**Federal Motor Truck Co.**, Detroit, is to construct a two-story brick and steel factory 95 x 308 x 34 ft. at the right of its present factory building, to cost \$45,000. Recently a large addition was built for office purposes and upon completion was immediately turned over to production. It is expected that a large part of the new factory will be used for the government work, as this company is working on Class B trucks.

**Taylor Motor Truck Co.** may continue to manufacture trucks in the old Burford plant at Fremont, O., according to an order by Federal Judge Killits to W. W. Morrison, president of the Continental Trust & Savings Bank, Toledo, trustee of the bankrupt Burford company. The court commands the trustee to turn the property over to the Taylor Motor Truck Co. as soon as an inventory is completed. Morrison is ordered to place all operations in the factory under observation and all business transacted by the company must be accounted for.

**Racine (Wis.) Motor Truck Co.**, incorporated several months ago, with a capital stock of \$500,000, to develop the Piggins Bros., motor truck manufacturing interests, will locate its headquarters at Appleton, Wis. A site has been purchased at Spencer and Story streets, and preparations are being made for the erection of a one-story concrete, brick and steel machine shop, 60 x 300 ft. The product will be motor trucks in 1¼, 2½, 4 and 6-ton capacities. 65 men will be employed at the start. The officers are: President, Ira L. Miller; vice-president and works manager, Charles Piggins; secretary and treasurer, B. F. Henline. It is expected that the corporate style will be changed to the Reliance Motor Truck Co.

## Body Builders

**Commercial Auto Body & Mfg. Co.**, Cleveland, O., has increased its capital from \$50,000 to \$150,000.

**Weigel-Warnsman Wagon and Auto Body Co.**, Cleveland, O., has increased its capital from \$25,000 to \$50,000.

**Auto Body Co.**, Lansing, Mich., is reported about to receive a contract for ambulance car bodies from the government.

**Piedmont Motor Car Co.**, Lynchburg, Va., will build a one-story extension to its plant, 50 x 150 ft., for the manufacture of automobile bodies.

**C. Stone & Sons Co.** body building plant at Chicago was destroyed by fire November 26. 25 complete cars and 150 bodies went up in smoke. It is stated that the loss amounts to \$175,000.

**Auto Body and Demountable Top Co.**, Buffalo, has been

incorporated with a capital of \$10,000 to manufacture automobile bodies and allied specialties. C. F. Otto, E. Lindner and E. Friedfeld, Buffalo, are the incorporators.

**Youngstown (O.) Auto Top Co.** has been incorporated with a capital stock of \$10,000, by Charles L. McCoy, Edwin J. McCoy, and others. It will manufacture bodies for motor trucks, automobile tops and similar products.

**Hale & Kilburn Co.**, Philadelphia, besides doing a large business with trolley lines, supplying bodies for cars, also has established itself in the automobile industry as a manufacturer of automobile bodies of a high type. During the last two years the volume of business has increased 150 per cent. Unfilled orders on hand at the beginning of this year totaled \$3,250,000. A readjustment of finances is being drafted to meet the new conditions.

### Car Builders

**Comet Automobile Co.**, Decatur, Ill., expects to occupy the first unit of its factory about December 15.

**Reo Motor Co.**, Lansing, Mich., has been assured some shrapnel case contracts and to that end certain changes in machinery are being made.

**Grant Motor Corp.**, Cleveland, O., is building two additions to its factory at Santa Cruz, Cal., 160 x 647 ft., and 160 x 400 ft.; also a two-story office building, 40 x 160 ft.

**Rush Motor Co.**, Camden, N. J., has been incorporated with a capital of \$100,000 to manufacture automobiles. Elmer Johnson, Jacob Liffman and Nathan Raidemann, Camden, are the incorporators.

**Dodge Bros.**, Detroit, has increased its capitalization from \$6,000,000 to \$10,000,000. Part of the increase will be used to defray the expense of the enlargement of the plant to take care of government orders.

**Stutz Motor Car Co.**, Indianapolis, is building a one-story brick and steel addition to its plant, 92 x 182 ft., for the manufacture of four-cylinder automobile motors. It is expected to be in operation by January 1.

**Ford Motor Co.**, Detroit, has received an order for 5,000 Liberty motors from the Aircraft Production Board. It is now largely engaged in the manufacture of airplane cylinders and is about to begin the production of ship fittings.

**Stanley Motor Carriage Co.**, Newton, Mass., is building an addition, 64 x 100 ft., two stories. This is the first step in the expansion of the plant following the recent reorganization of the company, which has been manufacturing steam motor cars since 1901.

**Holmes Automobile Co.**, Canton, O., which was formed last January to market a new air-cooled passenger car, expects to have its new models on the market in the near future and is now arranging for a distribution organization. Electric japanning ovens are being installed.

**Fabrica de Automoviles**, Monterey, Mexico, has been incorporated with a capital stock of 600,000 pesos which is equivalent to about \$300,000 gold. It is stated that the company will build a plant for the manufacture of the bodies, chassis and other parts of automobiles and their assembling. Luther L. Lane, of Brownsville, Tex., promoted the organization of the company and is its acting president. Its larger stockholders include a number of

the wealthiest business men of Monterey and northern Mexico. J. G. Zambrano, of Monterey, business associate of Nicaforo Zambrano, governor of the state of Neuvo Leon, is acting secretary and treasurer.

### Parts Makers

**Kelsey Wheel Co.**, Detroit, is to erect a one-story storage shed 100 x 140 ft.

**New Wapakoneta Wheel Co.**, Wapakoneta, O., is reported to be considering enlarging its plant.

**Sheldon Axle & Spring Co.**, Wilkes-Barre, Pa., will build a two-story extension to its axle department, 60 x 200 ft.

**Thomas Paulson & Son, Inc.**, Brooklyn, operating a brass foundry at 97 Second avenue, has increased its capital from \$30,000 to \$100,000.

**Wire Wheel Corp. of America**, New York, has leased property, about 100 x 100 ft., at 829-35 Eleventh avenue, for the establishment of new works.

**Jeffrey-Dewitt Co.**, Detroit, maker of spark plugs and other automobile specialties, it is reported will establish a branch plant at Huntington, W. Va.

**Reading Chassis & Motor Corp.**, New York, has been incorporated with a capital of \$100,000, to manufacture automobile parts. C. W. Bliss, S. S. Shears and E. Cahn, 233 Broadway, New York, are the incorporators.

**Radiator Service Co.**, Providence, R. I., has purchased the radiator department of the Metallic Shell & Tube Co., and will manufacture American radiators for the trade in addition to rebuilding and repairing all makes of radiators.

**J. A. Fay & Egan Co.**, Cincinnati, it is reported, will remove its plant to Bond Hill suburb. The company purchased a building site three years ago, but was held up in its plans by the lack of street car service for its workmen, which has now been remedied by the extension of a city car line.

### Philippine Trade in Motor Vehicles

Few Philippine imports have had so good a market during the last five or six years as that enjoyed by motor vehicles. With but two exceptions there has been an increase each year since 1911 in the number of automobiles imported.

At the close of 1916 there were in actual operation in the Philippine Islands 3,013 automobiles, 392 motor trucks, and 870 motorcycles. Besides these there were 1,630 machines undergoing repairs or not in operation for some other reason. The greater part of the latter number were automobiles.

Of the total number, 1,481 automobiles, 248 motor trucks and 323 motorcycles were being operated in the city of Manila. The Province of Occidental Negros, one of the sugar provinces, came next on the list with 234 automobiles, 3 trucks and 34 motorcycles. Other provinces surpassed this one in the number of motor trucks operated. Leyte has 29, Laguna and Iloilo each has 17, Benguet 16, and Ambos Camarines has 14. Iloilo has 159 automobiles, Rizal Province 148, and Cebu 125. It is probable that fully 400 more have been put in operation throughout the islands since the beginning of 1917, although exact data on this are not available.

**Leads World in Wealth**

The per capita wealth of the United States is \$2,030; that of Great Britain, \$1,751; of France, \$1,522; Germany, \$1,355. Our present national debt is \$33 per capita, or will be after the \$1,800,000,000 war budget is passed; that of Great Britain, \$370; France, \$360; Germany, \$290. We could pay our debt 169 times over without being "broke." We have \$25,000,000,000 of "liquid" money, subject to check, in our bank deposits. Our trade balance in 1902 was \$478,000,000; in 1916 it was \$2,000,000,000, a 500 per cent increase in 14 years.

**WANTS**

Help and situation wanted advertisements, 1 cent a word; all other advertisements in this department, 5 cents a word; initials and figures count as words. Minimum price, 30 cents for each advertisement.

**Wanted**—Copies of The Hub of May and July, 1916. Must be in good condition. Address Trade News Publishing Co., corner Elm and Duane streets, N. Y. City.

**PATENTS**

**Patents**—H. W. T. Jenner, patent attorney and mechanical expert, 606 F St., Washington, D. C. Established 1883. I make a free examination and report if a patent can be had and exactly what it will cost. Send for circular.

**HELP WANTED**

**Wanted**—Factory manager, one who has practical experience in building commercial auto bodies and vehicles. Fine opening for right man. Address, Bodies, care The Hub, 25 Elm street, New York.

**W. A. Sayers' Estate Goes to Widow**

Under the will of William A. Sayers, late head of the Sayers & Scoville Co., formerly large manufacturers of carriages, but now engaged in the automobile manufacturing business, his entire estate is left to his widow, Frances M. Sayers, who is also named executrix. The value of the estate is not estimated.

**To Manufacture Tires in Havana**

A firm to manufacture automobile tires and all kinds of rubber goods under the name of the Cuban Tire & Rubber Co. has been established in Havana, Cuba. It is stated that it intends also to put in rubber restoring machinery, thereby using old rubber that is to be purchased there.

**PORTER'S BOLT CLIPPERS**

"Easy" "New Easy" Allen-Randall



To Cut 5-16, 3-8, 1-2, 5-8, 3-4 Inch.

**H. K. PORTER, EVERETT, MASS.**

**"Quickwork"**

Sheet Metal Working Machinery

For Automobile and Carriage Bodies, Fenders, Hoods, etc.

**THE QUICKWORK CO.**

H. COLLIER SMITH, Pres. and Gen. Mgr. ST. MARYS, O.

**Leaders in their class for over three-quarters of a century**

**FABRICS  
BRIDGEPORT  
FABRICS**

**comprise an elegant assortment of the newest weaves, shades and patterns in automobile upholstery materials**

*WRITE FOR SAMPLES OF OUR*

**LIMOUSINE LININGS, CLOTHS, CARPETS, HORSE-HAIR CARPETS, CURTAIN SILKS, LACES, SEAT COVER FABRICS**

**We also supply ROBE RAILS, SPEAKING TUBES and TOILET CASES to match upholstery**

**BRIDGEPORT COACH LACE CO.**

**NEW YORK OFFICE, 1733 BROADWAY**

**BRIDGEPORT, CONN.**

The  
**Laidlaw Company**

Inc.  
New York City

: : : : :

**Automobile  
Fabrics**

: : : : :

**A Fabric for  
Every Purpose  
For Closed, Open or  
Convertible Bodies**

**steel  
stampings**

*especially for*  
**COMMERCIAL TRUCKS**

**The Pressed Steel Company  
Wilkes-Barre, Pa.**

**Index To Advertisers**

American Motors Corporation.....	6
Barrell Co., Wm. L.....	42
Bliss, E. W., Co.....	3
Bradley, C. C., & Son.....	45
Bridgeport Coach Lace Co.....	39
Century-Plainfield Tire Co.....	43
Century Steel Co. of America, The.....	4
Columbus Bolt Works.....	Back cover
Cowles, C., & Co.....	44
Crane & MacMahon, Inc.....	47
Decker, J. C.....	44
Dixon, Joseph, Crucible Co.....	9
Dowler, Chas. L.....	44
Doxey, N. D.....	43
DuPont Fabrikoid Co.....	42
Eccles, Richard, Co.....	46
Empire Art Metal Co., Inc., The.....	8
G & O Mfg. Co.....	47
Gray, Peter, & Sons, Inc.....	45
Hartford Auto Parts Co.....	3
Hoopes Bro. & Darlington.....	47
Hotel Rochester .....	45
Johnston, R. F., Paint Co.....	44
Judd & Leland Mfg. Co.....	43
Keratol Co., The.....	42
Laidlaw Co., The.....	40
Mulholland Co., The.....	44
Norton Grinding Co.....	5
Parrott Varnish Co., The.....	41
Paulson, Thomas, & Son, Inc.....	Back cover
Pettingell Machine Co.....	7
Pierce Co., F. O.....	Back cover
Pittsfield Spark Coil Co.....	41
Porter, H. K.....	39
Poughkeepsie Utilities Corporation.....	45
Pressed Steel Co.....	40
Quickwork Co., The.....	39
Rome-Turney Radiator Co.....	46
Russell, Burdsall & Ward Bolt & Nut Co.....	45
Sheldon Axle & Spring Co.....	10
Standard Oil Cloth Co., Inc.....	2
Wayne Wheel Co.....	41
West Tire Setter Co.....	47
White-Quehl Mfg. Co.....	44
Wilcox Mfg. Co., D.....	47
Wiley Co., C. A.....	46
Williams, J. H., & Co.....	Front cover
Wing, Chas., Co.....	44
Yoder Company, The.....	4

Please mention "The Hub" when you write

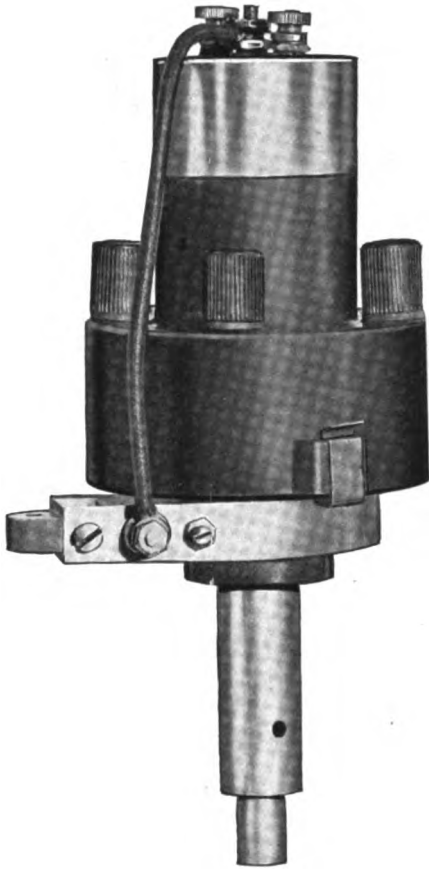

## A Perfectly Synchronized Spark at ALL Speeds

"Pittsfield" Distributor is of unit construction. It has an absolutely mechanical make and break which is positive and independent of spring action. No trips, hammers or other unreliable devices are required or used.

Its make and break is positive, giving a perfectly synchronized spark at all speeds. There is no lag in the spark—no automatic advances required.

Send for folder fully describing the "Pittsfield"

### FORD OWNERS

We have developed a special bracket for installing the "Pittsfield" Distributor on Ford Cars. Send for Folder.

Also manufacturers of "Pittsfield" Coils, Timers, Switches, "Berkshire," "Jewell," and "Mecatite" Spark Plugs.

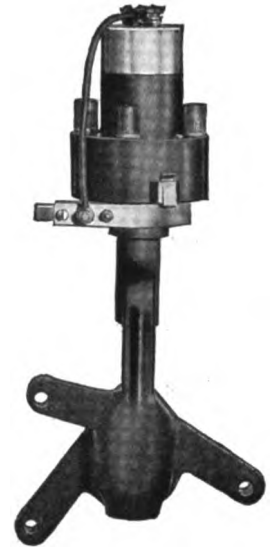

**PITTSFIELD SPARK COIL CO.**  
PITTSFIELD, MASS.

## PARROTT VARNISHES



.. Unequaled for ..

**Automobile  
and  
Carriage  
Finishing**

**The Parrott Varnish Co.**  
Bridgeport, Conn.

## AUTOMOBILE WHEELS

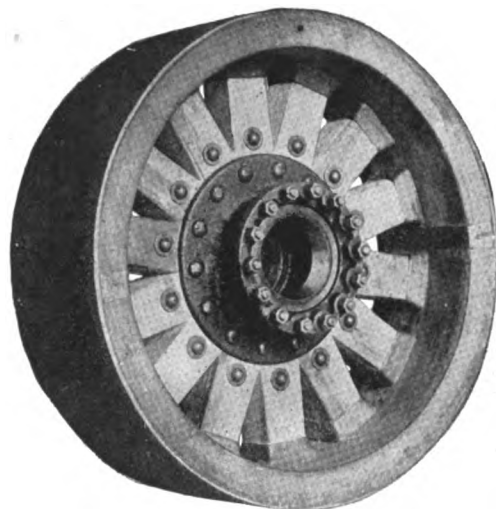

Have you seen our *new* construction?  
Better write us for particulars.

**Wayne Wheel Co.**  
Newark, Wayne Co., New York



# Keritol LEATHER SKINS

For the car where leather has always been used



**PRICE**

*Within Reason*  
**QUALITY**  
*Maintained*

**W<sup>m</sup> L. BARRELL Co.**      **8 THOMAS ST.  
NEW YORK**

**F DU PONT  
FABRIKOID**

REG. U. S. PAT. OFF.

## TRUCK SPECIAL

**As Rugged As the Service It Is Made for**

**Behind the Firing Line or on the Busy Street TRUCK SPECIAL  
Meets Every Test of Service**

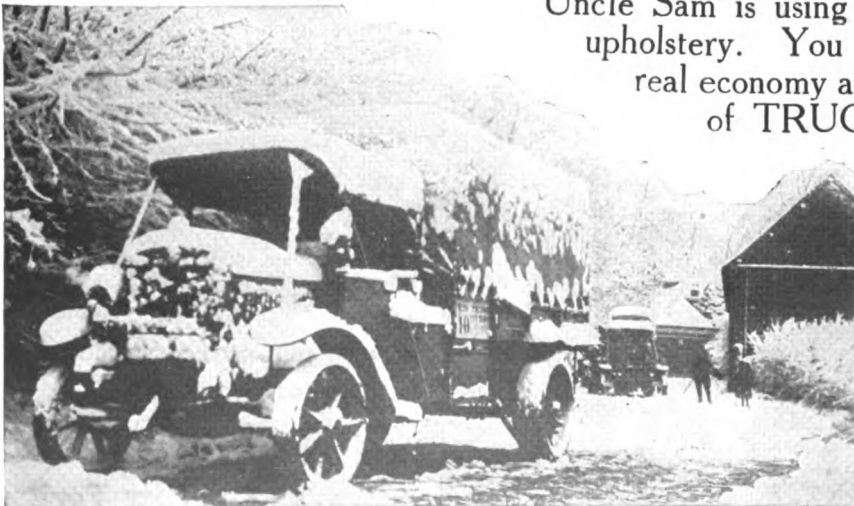

Uncle Sam is using leather substitutes for truck upholstery. You will if you investigate the real economy and splendid wearing qualities of TRUCK SPECIAL.

TRUCK SPECIAL is water-, grease-, stain-proof and cleanable. It insures maximum comfort, cleanliness and durability.

*Let us send you samples  
and quote prices*

**Du Pont Fabrikoid Co.**  
**Wilmington, Del.**

Underwood & Underwood, N. Y.

Please mention "The Hub" when you write.



# ANCHOR WELDING COMPOUND

MANUFACTURED BY  
**N. D. DOXEY, ELMIRA, N. Y.**

ANCHOR WELDING COMPOUND will weld hardest steel. Will not peel apart at the weld, thus losing the heat, nor burn up when flowing on the lap. Will weld without the use of hammer. Place two flat surfaces together in the fire, smelting the Compound liberally on the parts and press pieces together firmly with tongs, and weld will be complete without a stroke of the hammer. It will not require any iron fillings to be added in welding as in some other compounds. It does the work itself. A weld made with ANCHOR COMPOUND leaves the welded parts of equal strength with solid parts of the metal. Cannot be damaged by dampness nor by heat.

Your Welding Compound gives entire satisfaction. In welding steel of high carbon, it fluxes quick and the steel appears like iron, and can be worked at a white heat. I have tried all other compounds in the market and can pronounce yours the best. It flows where you want it to flow.

C. H. KILMER, Elmira, N. Y.

We take pleasure in stating that we have been using your Welding Compound for several years and find it a most excellent article, and can recommend it highly. Yours truly,

THE LAFRANCE FIRE ENGINE CO.

W. Falck, Gen. Manager, Elmira, N. Y.

Is used by U. S. Navy and C. & N. W. Ry. Co. and many others.

IN USING do not throw the Compound from the surface to be welded, but cup the scarf, and in light work turn the piece, when ready for welding, so that the Compound will flow evenly over the surface to be welded, which it will readily do, flowing like oil. In heavier work, add compound to surface to be welded, as heat nears welding point, so that surface to be welded is covered with fused compound.

## The Best Hand Pump THE VICTOR



Must have brass tubes that will not rust or cut out the cups.

It must be quick in action. Motorists do not allow for tire troubles in arranging their schedules.

The cups must be of selected leather to give long service.

The design must be simple and easily understood.

This is  
such a pump

NOT BEST BECAUSE IT WAS FIRST  
BUT FIRST BECAUSE IT IS BEST

ASK ABOUT IT OF

**JUDD & LELAND MFG. CO.**  
CLIFTON SPRINGS, N. Y.



# Superbar Tires

"Service Tires"

Made of high grade fabric and best grades of pure rubber to meet the demand of those who seek a good Standard Quality Tire giving maximum amount of service for money invested.

Built by HAND throughout.

SUPERBAR Tires are the result of many years of scientific experimenting and combine quality of material, skill in workmanship and a maximum of road resistance.

Adjusted on 3,500-mile basis. Ford sizes, 4,500-mile basis.

Splendid agency opportunities are available; particulars on request.

## Century-Plainfield Tire Co.

Plainfield, N. J.

Century-Plainfield Tire Company, a subsidiary of the Rubber Metals Corporation, exclusive manufacturers of the Rimco Rubber Products by the Elchemco process

Please mention The Hub when you write

# BUSY BUYERS BRIEFS

## JOHNSTON'S KRAKNO

Color Card Free  
\$3.50 per gallon  
The R. F. Johnston Paint Co.  
Cincinnati, Ohio

## THE CHARLES WING CO.

Established 1848  
Manufacturers and Wholesale Dealers in  
**AUTOMOBILE AND CARRIAGE  
HARDWARE AND TRIMMINGS**  
AMESBURY, MASS., U. S. A.

## Why Not Have the Best?

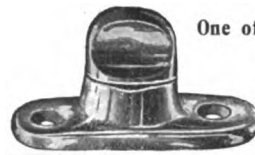

One of a Large Variety

G. Cowles & Co.  
NEW HAVEN,  
CONN.

## J. C. DECKER

MONTGOMERY, PA.  
Manufacturer of  
**Carriage, Skate and Pad Straps**  
Side Loops, Bridle Fronts, Tail Ties, etc.

## CHARLES L. DOWLER

CARRIAGE AND WAGON HARDWARE  
108 North Third St., Philadelphia, Pa.  
**CUSHION MANUFACTURER**  
Pure Stearic Acid Candles. Wheel Stock. Snow  
Flake Axle Grease.

## MULHOLLAND BUGGY SPRING

Reduces weight of springs one-half.  
Made in one size only but will fit bodies  
of all widths.  
Write for further particulars and prices.  
THE MULHOLLAND CO. DUNKIRK, N. Y.



LINED



UNLINED

## White's Brazing Sleeves

For applying Rubber Tires  
Send for Samples.

## WHITE-QUEHL MFG. CO.

431 E. Pearl St.  
CINCINNATI, OHIO

# CLASSIFIED INDEX

For Addresses See Alphabetical Index  
and Advertising Pages

### ANTI-FRICTION METALS

Thomas Paulson & Son, Inc.,  
Brooklyn, N. Y.

### AUTOMOBILES

American Motors Corp., Plain-  
field, N. J.

### AUTO FABRICS

Barrell, Wm. L., Co., New York  
Keratol Co., The, Newark, N. J.  
Laidlaw Co., Inc., The, New  
York.  
O'Bannon Corp., New York City  
Standard Oil Cloth Co., New  
York City.

### AUTO PARTS

Hartford Auto Parts Co., Hart-  
ford, Conn.

### AXLES (Including Ball and Roller Bearing)

Sheldon Axle & Spring Co.,  
Wilkes-Barre, Pa.

### BOLTS AND NUTS

Columbus (O.) Bolt Works Co.  
Russell, Burdsall & Ward Bolt  
& Nut Co., Port Chester, N.Y.

### BOLT CLIPPERS

Porter, H. K., Everett, Mass.

### BRAZING SLEEVES

White-Quehl Mfg. Co Cincin-  
nati, O.

### DIES

Bliss Co., E. W., Brooklyn, N.Y.  
(Sheet Metal Working).

### FORGINGS

Eccles, Richard, Auburn, N. Y.  
(Carriage, Drop).  
Williams, J. H., & Co. Brook-  
lyn, N.Y. (Automobile, Drop)

### FIFTH WHEELS

Wilcox Mfg. Co., D., Mechanics-  
burg, Pa.

### HARDWARE (Carriage, Wagon and Automobile)

Columbus (O.) Bolt Works Co.  
Dowler, Chas. L., Philadelphia.  
Eccles Co., Richard, Auburn,  
N. Y.  
Wilcox Mfg. Co., D., Mechan-  
icsburg, Pa.  
Wing Co., Chas., Amesbury,  
Mass.  
Cowles, C., & Co., New Haven,  
Conn.

### LEATHER SUBSTITUTES

Barrell Co., Wm. L., New York.  
DuPont Fabrikoid Co., Wil-  
mington, Del.  
Keratol Co., The, Newark, N. J.  
O'Bannon Corp., New York City  
Standard Oil Cloth Co., New  
York.

### LUBRICANTS

Dixon, Jos., Crucible Co., Jer-  
sey City, N. J.

### MACHINERY AND TOOLS

Bliss Co., E. W., Brooklyn, N.Y.  
Norton Grinding Co., Worces-  
ter, Mass.  
Pettingell Machine Co., Ames-  
bury, Mass.  
Simmons Machine Co., Inc.,  
Albany, N. Y.; Singer Bldg.,  
New York City.  
Smith, H. Collier, Detroit, Mich.  
West Tire Setter Co., Roches-  
ter, N. Y.  
Williams, J. H., & Co., Brook-  
lyn, N. Y.  
White-Quehl Mfg. Co., Cincin-  
nati, O.  
Yoder Co., The, Cleveland, O.

### MACHINERY (Metal Working)

Bliss Co., E. W., Brooklyn, N.Y.  
Pettingell Machine Co., Ames-  
bury, Mass.  
Quickwork Company, Detroit,  
Mich.  
Yoder Co., The, Cleveland, O.

### METAL STAMPINGS AND NOVELTIES

Gray, Peter, & Sons, Inc., Cam-  
bridge, Mass.  
Pressed Steel Co. of New York,  
New York City.

### PATENTS

Jenney, H. W. T., Washington,  
D. C.

### PAINTS AND COLORS

Johnston Paint Co., R. F., Cin-  
cinnati, O.  
Pierce Co., F. O., New York.  
Willey Co., C. A., Hunter's  
Point, N. Y.

### PRESSES

Bliss Co., E. W., Brooklyn, N.Y.  
(Drop, Power).

### RADIATORS

G. & O. Mfg. Co., New Haven,  
Conn.  
Rome-Turney Co., Rome, N. Y.

### SCHOOL FOR DRAUGHTS- MEN

Mechanics' Institute, New York

### SHAFT COUPLINGS

Bradley & Son, C. C., Syracuse,  
N. Y.  
Eccles Co., Richard, Auburn,  
N. Y.

### SPARK COILS

Pittsfield Spark Coil Co., Pitts-  
field, Mass.

### SPRINGS

Mulholland Co., Dunkirk, N. Y.  
Sheldon Axle & Spring Co.,  
Wilkes-Barre, Pa.

### STEEL

Century Steel Co. of America,  
Poughkeepsie, N. Y.; Sales  
office, 120 Broadway, N. Y.

### TIRES

Century-Plainfield Tire Co.,  
Plainfield, N. J.  
**TIRE PUMPS**  
Judd & Leland Mfg. Co., Clifton  
Springs, N. Y.

### TOOLS

Williams, J. H., & Co. Brook-  
lyn, N. Y.

### TRIMMING MATERIAL

Bridgeport (Conn.) Coach Lace  
Co.  
Decker, J. C., Montgomery, Pa.  
Wing Co., Chas., Amesbury,  
Mass.

### UNIVERSAL JOINTS

Hartford (Conn.) Auto Parts  
Co.

### VARNISH AND JAPAN

Parrott Varnish Co., Bridgeport,  
Conn.  
Pierce Co., F. O., New York.  
Willey Co., C. A., Hunter's  
Point, N. Y.

### VARNISH RENOVATOR

Poughkeepsie (N. Y.) Utilities  
Corp.

### WELDING COMPOUND

N. D. Doxey, Elmira, N. Y.

### WHEELS

Crane & MacMahon, Inc., New  
York City.  
Hoopes Bros. & Darlington,  
Inc., West Chester, Pa.  
Wayne Wheel Co., Newark, N.J.

### WOOD BENDINGS, WHEEL STOCK, ETC.

Crane & MacMahon, Inc., New  
York City.

Please mention "The Hub" when you write



**TEMPERED STEEL RING**

**LEATHER PACKING**

The Only One-piece Moulded Leather Packing

## The Bradley Carriage Coupler

*All-Steel    Noiseless    Quick-Shifting    Ball-Bearing*

(MADE IN FIVE SIZES FOR AXLES 1/4 INCH TO 2 1/4 INCH)

The *only* carriage coupler that is furnished with a **ONE-PIECE MOULDED LEATHER PACKING**

**C. C. BRADLEY & SON, Syracuse, N. Y.**

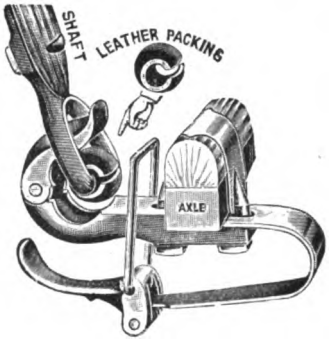

**SHAFT**    **LEATHER PACKING**

**AXLE**

The Bradley Carriage Coupler

## HOTEL ROCHESTER

Rochester, N. Y.

"A Tone All Its Own"



300 Rooms with Bath

One of the Finest Equipped Hotels in the World  
**EUROPEAN PLAN \$1.50 UP**  
 Club Features in Restaurant

MILTON ROBLEE, Manager

## Sheet Metal Specialties



WE are in a position to furnish *Sheet Metal Stampings* in all kinds of metal at the rate of several hundred thousand pieces per day.

Special attention given to rush orders.  
 Send us your inquiry with specifications.

**Peter Gray & Sons, Inc.**  
 Cambridge, Mass.

## UTILITY VARNISH RENOVATOR

*"The ONE that WILL"*

Preserve the fine finish of your automobile

ECONOMICAL TO USE  
 EASY TO APPLY  
 EFFECTIVE IN RESULTS

FOR SALE BY GARAGES, AUTO ACCESSORY AND HARDWARE STORES

Manufactured by  
**POUGHKEEPSIE UTILITIES CORP., 46 Winnikee Ave., Poughkeepsie**

## RUSSELL, BURDSALL & WARD BOLT & NUT CO.

Established 1845                      PORT CHESTER, N. Y.

**MAKERS OF THE CELEBRATED EMPIRE BOLTS AND NUTS**

Western Office: **Continental & Commercial Bank Bldg., Chicago, Ill.**    Branch Works: **Rock Falls, Ill.**

Please mention "The Hub" when you write

# RADIATOR INSURANCE

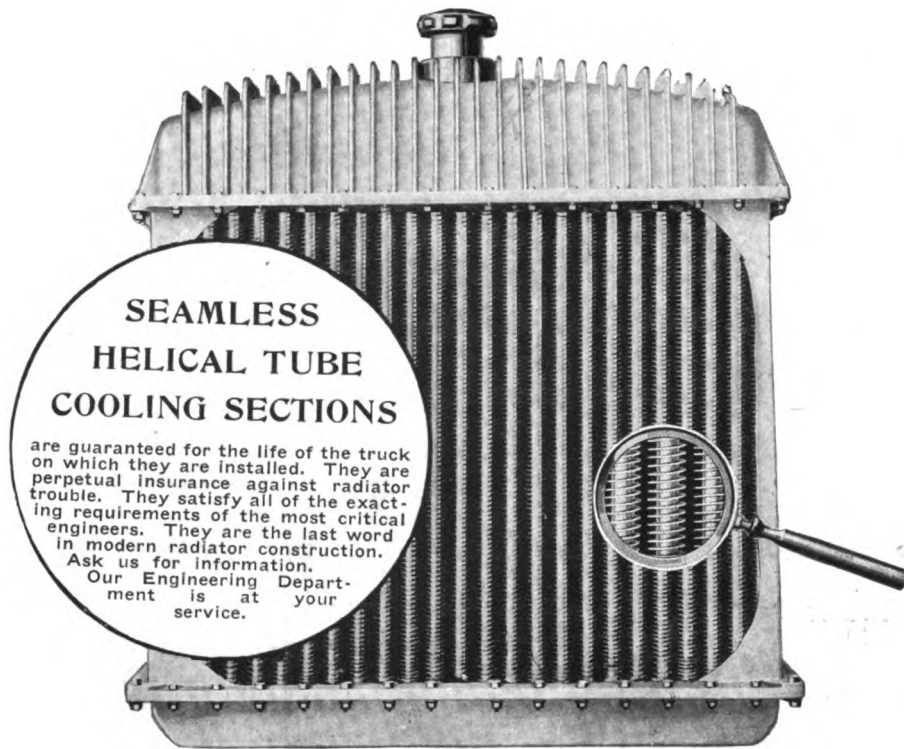

ROME-TURNEY RADIATOR CO., Sole Manufacturers, ROME, N. Y.

## WILLEY'S COLORS

The Recognized Standard



**C. A. WILLEY CO.**

**COLOR GRINDERS**

and Manufacturers of Specialties in

**CARRIAGE, AUTOMOBILE and CAR**

**PAINTS**

**COLORS, VARNISHES, ETC.**

**HUNTER'S POINT, NEW YORK CITY**

## Automobile, Carriage, Wagon and Special **FORGINGS**

**of Guaranteed Quality**

When you are in the market, send us your blue-prints for quotations.

Ask for catalog showing part of our large line of Automobile and Special Forgings, also catalog listing our full line of Carriage and Wagon Hardware.

**Richard Eccles Co.**

**AUBURN, NEW YORK**

ESTABLISHED IN 1880



# HOOPES BRO. & DARLINGTON

(INCORPORATED)

## WEST CHESTER, PA.

WE ARE MAKING

# AUTOMOBILE WHEELS

Forty Years' Experience as WHEEL MAKERS is guarantee we can make good ones.  
Will not make any other kind. Try them.



ENGINE COOLING

# RADIATORS

FOR PLEASURE CAR AND HEAVY DUTY SERVICE

G & O MFG. CO. - New Haven, Conn.

# WILCOX

FINE  
FINISHED  
FORGED

## CARRIAGE HARDWARE AND GEAR IRONS

Write for Prices and Catalog

### The D. Wilcox Mfg. Co.

MECHANICSBURG, PA.

## The WEST Hydraulic Tire Setter

### WILL CUT DOWN EXPENSE

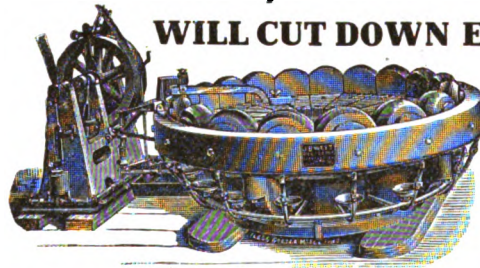

Tires set cold in one minute. This machine saves time—does the work better and quicker, does a way with burned streaks. Only necessary to measure one wheel in a lot. Does not char the rim, and

thus make the tire loosen prematurely. Saves resandpapering of wheels. This machine is now increasing the profits of many manufacturers. Send for catalog and read about it.

**WEST TIRE SETTER CO., ROCHESTER, NEW YORK**

# AUTOTRUCK

## Hickory Nut and

BEST QUALITY STOCK  
TOUGH AND HEAVY  
BONE DRY

MANUFACTURED BY  
CAPABLE MECHANICS  
AND MOST  
IMPROVED MACHINERY

WHEELS WHICH ADD TO  
THE LIFE OF YOUR TRUCK

ST. MARYS, OHIO

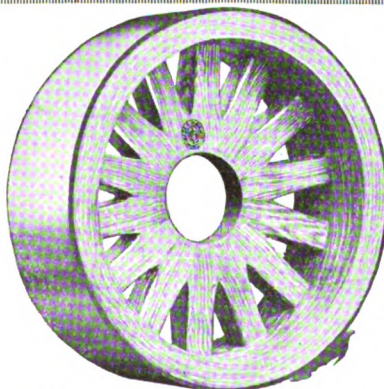

**CRANE & MacMAHON, Inc.**

# WHEELS

## Acorn Brands

HORSE-DRAWN  
VEHICLE WHEELS  
ALL STYLES

TRAILER WHEELS:  
SARVEN AND  
ARTILLERY TYPES

HIGH STANDARD OF  
QUALITY AND  
WORKMANSHIP  
MAINTAINED

8 BRIDGE ST., N. Y. CITY

Please mention "The Hub" when you write

*The Hub*

# F. O. PIERCE COMPANY

NEW YORK, U. S. A.

Manufacturers of High Class Pigment Colors

## FOR AUTOMOBILE PAINTING

Made from ORIGINAL FORMULAE.

Colors ground in Japan and other MEDIUMS

to meet any SYSTEM of APPLICATION

We can now supply Uzatona in Japan, Oil or Varnish. Prices upon application

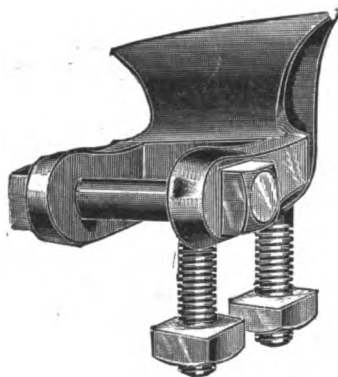

### Skewed Shaft Couplings

**Regular or Oval Patterns  
For High Arched Axles**

Furnished in rights and lefts for any height of arch.

Oval Axle Clips  $\frac{5}{8}$  or  $\frac{3}{4}$  width to match Oval  
Couplings. Bolts, Clips, Couplings, Carriage  
Hardware and Special Forgings

Catalogue "H" and Prices on Application

**COLUMBUS BOLT WORKS COMPANY**

COLUMBUS, OHIO

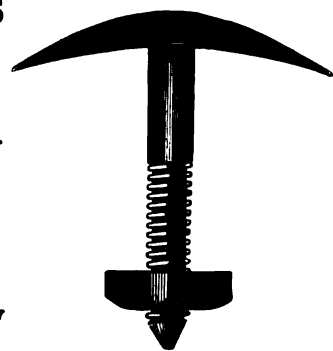

The machinery of the country is running at top speed to supply war needs. Machines are supplementing man power to make up for labor

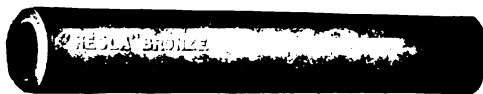

shortage. The wheels **MUST** be kept turning—automobiles, gas, oil and steam engines, railway trucks, generators and everything that runs in bearings.

## **"HECLA" ANTI-FRICTION BRONZE**

will keep them moving, smoothly and efficiently. This alloy is the result of 32 years' experience and research. "HECLA" WILL NOT CUT the journal or pin under the severest service conditions. Will not pound out or break, MACHINES CHEAPLY and has NO SUPERIOR regardless of price. Let us send the little "Hecla" booklet. We also make Castings—finished or rough, in Brass, Bronze, Aluminum, Hydraulic Metals, Copper, Acid Metal.

**BRASS FOUNDERS  
ENGINEERS**

**THOMAS PAULSON & SON, Inc.**

**97 SECOND AVENUE  
BROOKLYN, N. Y.**

# The Hub

First Journal of the Vehicle Industry

Vol. LIX

NEW YORK, JANUARY, 1918

No. 10

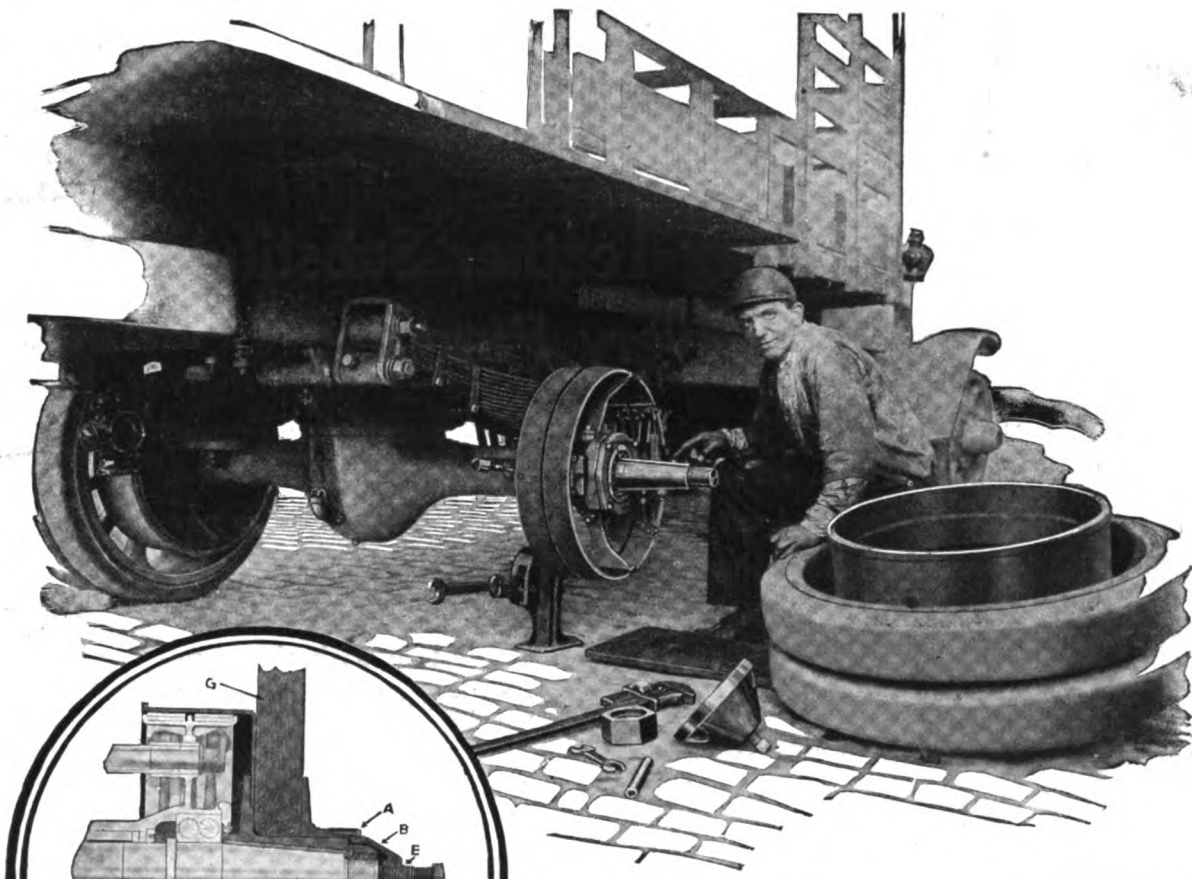

## See That Tapered Drive Shaft

That's another feature that makes possible the quick and easy demountability of the wheels from the Sheldon Worm Gear Semi-floating Rear Axle.

There are just six simple operations (see cut) necessary to remove a wheel from the Sheldon Worm

Gear Axle and they are easily understood and performed in a few minutes by any ordinary workman.

Service and utility are the keynote of Sheldon supremacy.

Write for more complete information.

Ready demountability of Sheldon wheel hub. Remove parts A, B and C, replace B (hub cap), insert E (set screw), and screw against shaft, tap back of wheel G till it comes loose.

# SHELDON

## WORM GEAR AXLES



SHELDON AXLE AND SPRING CO.

Makers of springs and axles for heavy duty service for more than fifty years

WILKES-BARRE, PA.



# MERITAS

---

## LEATHER CLOTH

### The Leading Leather Substitute For Every Purpose

The most varied line of weights, finishes, colors and grains is at your disposal in Meritas Leather Cloth.

For carriage and automobile trimming and upholstery purposes Meritas Leather Cloth is the recognized quality leader. Six enormous plants assure timely production. The largest organization of skilled workers in this line with the experience and knowledge required to produce dependable goods should mean something to you.

The trademark on the back of the goods guarantees the quality.

#### Write for Samples

State your requirements and we'll submit goods for your specific need.

**The Standard Oil Cloth Company**

INCORPORATED

320 Broadway

New York



# EXTREMES MEET

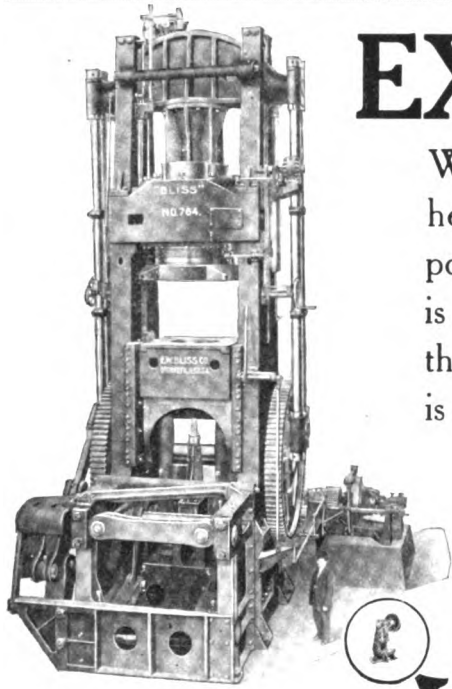

We're showing you the "biggest and the littlest" here side by side just to point to a fact—that every power press need of the sheet metal manufacturer is covered by "BLISS" lines. The tiny press in the circle (not so tiny at that, for it weighs 250 lbs.) is a Bench Press suitable for punching, blanking and forming light work. The big one that towers above its operator is a *Bottom Slide Toggle Drawing Press No. 764* especially adapted for producing large, heavy steel barrels, etc.

WE BUILD BOTH THESE PRESSES



## E. W. BLISS COMPANY



Main Office and Works: BROOKLYN, N. Y., U. S. A.

CHICAGO OFFICE: People's Gas Building  
 DETROIT OFFICE: Dime Bank Building  
 CLEVELAND OFFICE: Union Bank Building  
 LONDON, S. E., ENGLAND, Pooock Street, Blackfriars Road  
 PARIS, FRANCE, 100 Boulevard Victor-Hugo St. Ouen

1857

1918

**Hartford**  
**Universal Joints**

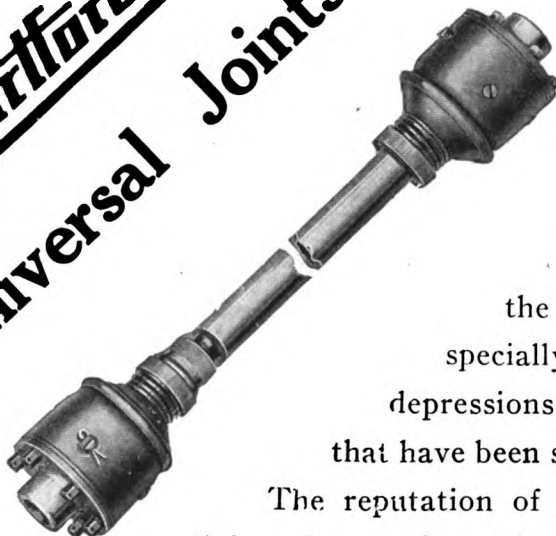

WE are able to offer manufacturers universal joints manufactured by specialists in one of the largest plants in the world.

The wearing surfaces of HARTFORD UNIVERSAL JOINTS are hardened and ground, the grinding being accomplished by a specially devised machine whose use eliminates depressions or elevations so common in steel parts that have been simply reamed.

The reputation of your car demands the best universal joints that can be made, and we have them.

# The Hartford Automobile Parts Co.

Established 1906

Hartford, Conn.

Please mention "The Hub" when you write.



# Yoder Sheet Metal Machinery

YODER  
CROWN  
ROLLING  
MACHINE

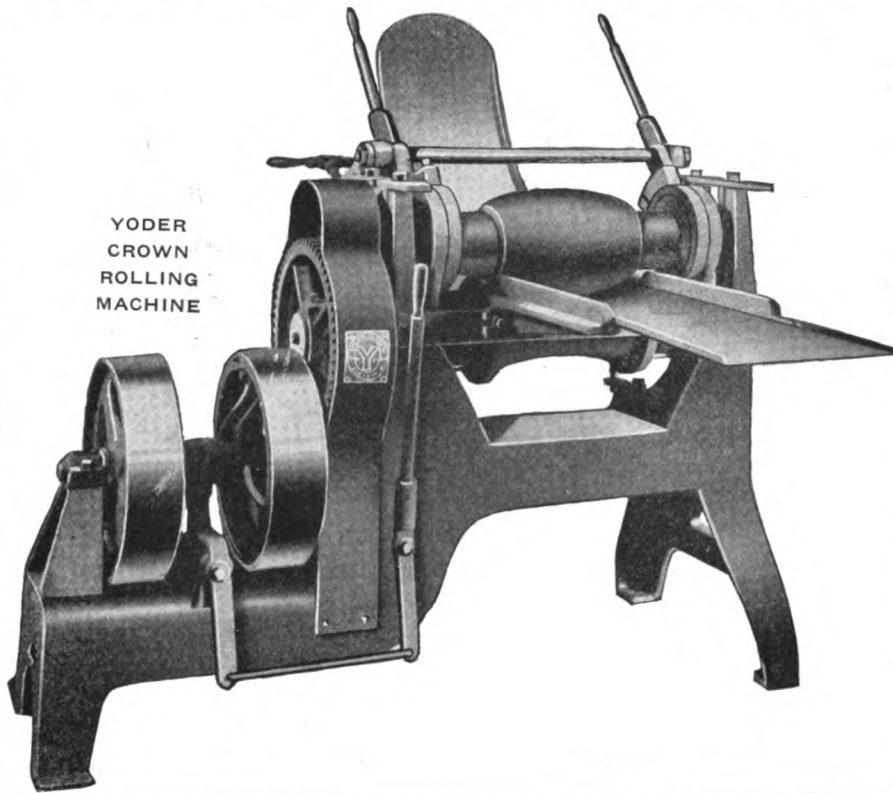

Our line of Auto Sheet Metal Working Machinery is efficient in every detail.

Every machine is constructed with the objective of producing perfect results at a minimum cost of material and labor.

The Yoder Company guarantees its machinery to produce results satisfactory to the purchaser.

We are glad to consider your Sheet Metal Machinery needs, as well as your requirements for special machines.

If you are thinking of making your own sheet metal parts or producing sheet metal products for the trade, get in touch with us at once. We can save you money and furnish a most satisfactory and complete equipment.

Catalog and prices furnished on request

**The Yoder Company**

Engineers Building

Cleveland - - Ohio

# CENTURY

“C. T. V. No. 5”

## Tungsten Valve Steel

Regular Analysis or to Special Analysis for  
TOUGHNESS RIGIDITY HIGH HEAT RESISTANCE

### THE CENTURY STEEL CO. OF AMERICA

Manufacturers of High-Grade Crucible Steels

General Office and Works:

**POUGHKEEPSIE, N. Y.**

CHICAGO SALES OFFICE:

E. P. Bartlett & Co., 15 N. Jefferson Street

PHILADELPHIA SALES OFFICE:

Century Steel Co. of America, Real Estate Trust Bldg.

CLEVELAND SALES OFFICE:

J. E. Rawson, Rose Building

NEW YORK SALES OFFICE:

Century Steel Co. of America, 120 Broadway

Please mention The Hub when you write



**N**OWHERE is fine finish more essential than in piston work for internal combustion engines. The slightest deviation from a mirror surface may cause damage through cylinder scoring. The accuracy of such work must by the same token be positive.

Norton Grinding Machines are successfully meeting in scores of Motor plants throughout the country these demands of accuracy and finish in cylindrical grinding. But they are not limited in their range to fine, delicate work: they are also meeting the problem practically and economically of metal reduction in rough grinding.

Let us advise you on the work that hasn't been quite satisfying you.

## **Norton Grinding Company**

Worcester, Mass.

Chicago Store:  
11 N. Jefferson St.

# **Norton Finish**





# **ANNOUNCEMENT**

In addition to our regular line of metal and wood auto body and aeroplane machinery, we have opened a department for the manufacture of **AUTOMOBILE HARDWARE** and are now in a position to supply many parts

**Windshields**

**Pedestal Bases**

**Rocker Plates**

**Hinges**

**Stock Clamps** (for use in wood mill)

**Special Parts**

**Aeroplane Hardware**

**Special Tools** (for body machinery)

We would suggest that manufacturers place their orders for hardware parts soon, as our supply is to be limited. If in need of any special parts **WRITE US** and we shall be glad to give you all information possible. Automatic Machinery enables us to turn out parts rapidly and at a low figure.

Get our prices before placing order

**Pettingell Machine Co.**

**Amesbury, Mass.**

# Stop Gears From Wearing

Every man has seen in the crank case of his engine a black, gritty substance that he has taken for sand or dirt, but which is really the little particles of steel that imperfect lubrication permits to grind off.

The same thing is going on in the gears and bearings even when good lubricants are used. Friction is the constant rubbing over each other of microscopic pins and roughnesses that are found even in the most highly polished bearings. Oil and grease merely smear these over. Heat thins the oil or grease and it runs out of these roughnesses. They are constantly wearing away and breaking off.

There is only one way to put a stop to this mischief. Dixon's selected flake graphite as combined in Dixon's Graphite Greases makes a lubricant that fills up every surface irregularity and puts an unctuous smooth veneer over the entire bearing, so that metal cannot come in contact with metal. A car thoroughly lubricated with Dixon's Graphite Automobile Lubricants gives greater satisfaction than a car doped with any other lubricant.

Buy a can of Dixon's Transmission and Differential Grease No. 677 and put this claim to a test.

All dealers and garages that give good service sell Dixon's Graphite Automobile Lubricants. *Write for Booklet No. 123-G*

**DIXON'S**  
GRAPHITE  
**Automobile**  
**LUBRICANTS**

Made in Jersey City, N. J., by the

**Joseph Dixon Crucible Company**



Established 1827



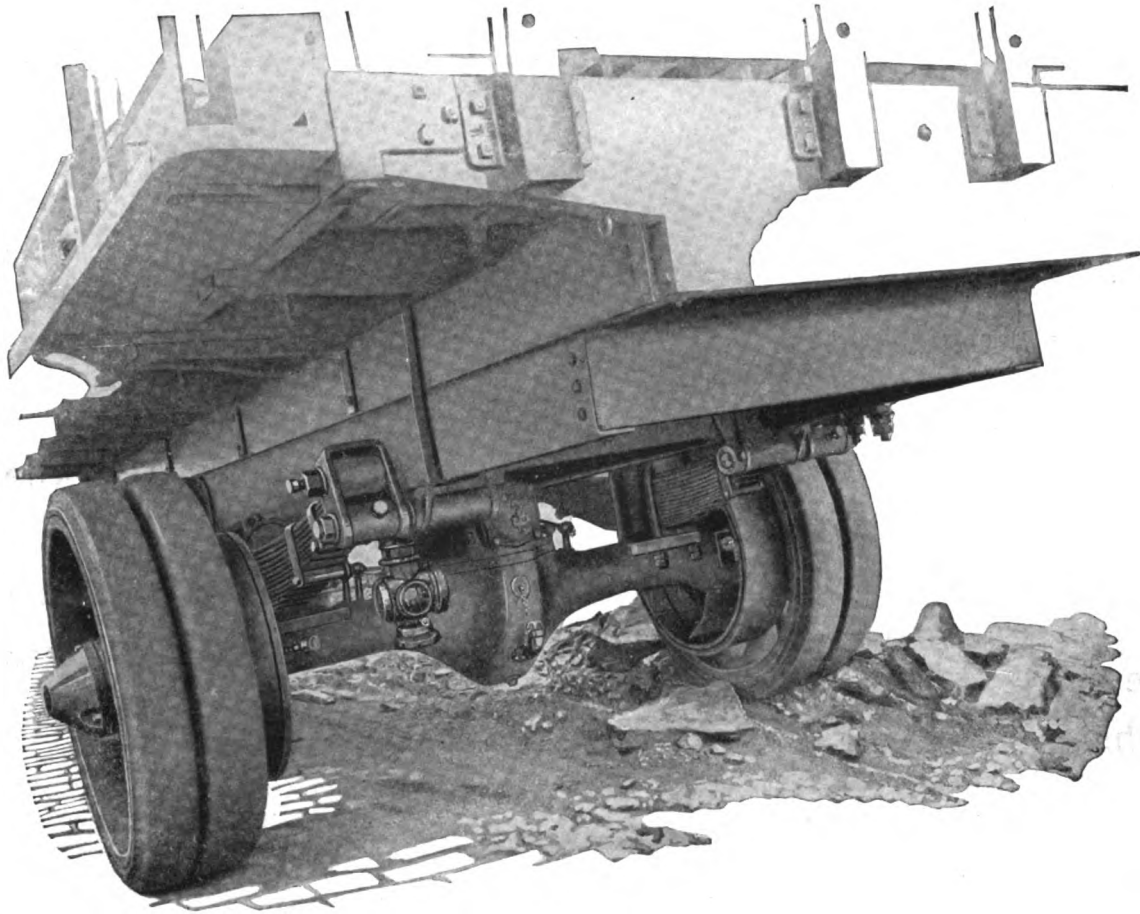

**WHEN YOUR TRUCK  
WITH ITS LOAD IS  
ROLLING ALONG**

In a straight line over a smooth surface, it is improbable that axle trouble will develop, even though the truck may be heavily overloaded.

But the moment that either wheel strikes a cobblestone a glancing blow, or brushes against a curb, then two tremendous rending forces, two opposed pressures which represent thousands of pounds of dead weight, immediately act to tear the axle apart.

Sheldon Worm Drive Axles, by virtue of their semi-floating construction, are fully safeguarded from damage against these destructive forces when they are applied at the wheel rim.

Furthermore: the Sheldon bearings placed at the inner end of the drive shaft and at the wheel receive far less wear than those in other types of axles where bearings are placed only in the wheel.

Thus Sheldon truck axles insure lower cost haulage by eliminating the causes of accidents and quick wear.

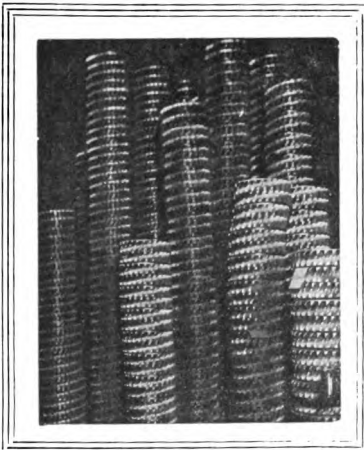

*A corner of the Worm Wheel Stock Room at Sheldon*

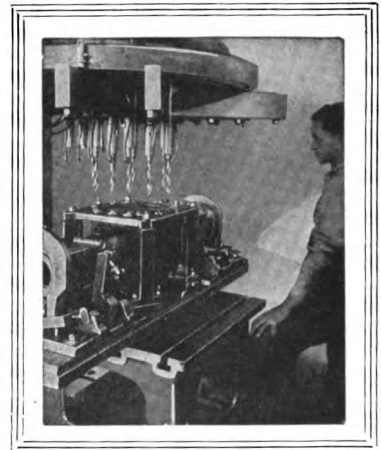

*Drilling 12 stud holes at once in a worm-gear axle housing*

**SHELDON**

**WORM GEAR AXLES**

**SHELDON AXLE & SPRING CO.** *Makers of springs and axles for heavy duty service for more than fifty years* **WILKES-BARRE, PA.**



# The Hub

Vol. LIX

NEW YORK, JANUARY, 1918

No. 10

Published Monthly by

## THE TRADE NEWS PUBLISHING CO. OF N. Y.

PAUL MORSE RICHARDS, *President* G. A. TANNER, *Secretary and Treasurer*

EDISON BUILDING, COR. ELM AND DUANE STS., NEW YORK

THE HUB, a monthly authoritative journal on all subjects pertaining to the vehicle industry from its engineering and construction viewpoints. It publishes information of live interest to manufacturers of motor vehicles, trailers, carriages, wagons, the accessory trades, repair shops and garages.

Subscription price for the United States, Mexico, Cuba, Porto Rico, Guam, the Philippines, and the Hawaiian Islands, \$2.00; Canada, \$2.50; payable strictly in advance. Single copies, 25 cents. Remittances at risk of subscriber, unless by registered letter, or by draft, check, express or post-office order, payable to the order of THE TRADE NEWS PUBLISHING CO.

For advertising rates apply to the publishers. Advertisements must be acceptable to publishers. Copy for new advertisements must be received by the 25th of the preceding month. All communications must be accompanied by the full name and address of writer.

Entered in the New York Post Office as Second-class Matter

## Tightening of War Grip

The grip of war upon the industries of the country has become more evident in the past month, the most pronounced demonstration being the action of the President in taking the railways completely under the government's control. The railways are the most important single factor in the industrial situation; every other industry has complained that it was limited by inadequate transportation service, and while this was the case it has seemed useless to apply the spur in other quarters. The advent of severe winter weather, which seriously reduces the capacity of the roads, brought matters to a crisis, and determined the President upon the course which he has taken.

Next to railway service, coal is the most vital necessity and the supply of this is so dependent upon transportation from day to day that when the latter fails it is difficult to say to what extent production is insufficient. The fact is that according to the figures compiled from month to month by the geological survey the production of bituminous coal this year will be approximately 50,000,000 tons greater than in 1916, when it exceeded all previous records. There are practically no stocks outside of consumers' hands, and the railroads have delivered this increased production.

In view of the fact that the industries were working at full speed throughout 1916 it seems remarkable that the situation should be so much more acute at this time than a year ago. The draft for the army has reduced the labor supply, and the output of the iron furnaces, which is basic material for many industries and usually accepted as significant of general conditions, has been slightly less in 1917 than in 1916. Nevertheless, there is a serious shortage of

coal, estimated by Director Garfield at 50,000,000 tons, and notwithstanding the great importance of getting full service out of ships, hundreds of ships have been delayed in Atlantic ports, waiting for coal.

To meet this situation Director Garfield issued an order on January 16 closing down for a period of five days, beginning at midnight Thursday, the 17th, substantially all manufacturing industries east of the Mississippi River and the states of Louisiana and Minnesota. The ten Mondays from January 21 to March 25, inclusive, were also designated as legal holidays, and the order closely restricts the use of coal on those days, in effect ordering the closing of stores, theatres and office buildings on each of the ten days. The publication of newspapers, however, is not restricted.

## War Spirit in Evidence at Palace Show

The opening of the 18th annual National Automobile Show, held at the Grand Central Palace, New York City, followed a period of cold weather never before experienced in New York both as to the length of its duration and severity.

The decorations were artistically designed in keeping with the martial spirit of the times. From the tall pillars on the main floor there was a generous display of the national colors and the flags of the Allies, interspersed with shields representing the "Flame of Liberty." Many of the exhibitors suspended service flags over their cars, showing the number of workers from the factory force in army or navy service. To designate the various makes there were hundreds of hand-painted curtains in imitation of tapestry bearing designs of crests, warriors, crusaders and coats of arms with the name of the car in gilt letters at the top.

## Steel Prices Extended

The President has approved the recommendation of the War Industries Board that the maximum prices fixed in September by the President upon the recommendation of the board upon ore, coke, pig iron, steel and steel products, subject to revision on January 1, 1918, be continued in effect until March 31, 1918. No new contracts calling for delivery of any of said commodities or articles on or after April 1, 1918, are to specify a price unless coupled with a clause making the price subject to revision by any authorized United States government agency, so that all deliveries after that date shall not exceed the maximum price then in force, although ordered or contracted for in the meantime. It is expected that all manufacturers and producers will observe the maximum prices now fixed.

## Motor Car Makers Plan Export Activity

Ways of extending the foreign trade in American motor cars were considered at a meeting of the export committee of the National Automobile Chamber of Commerce held in New York, January 10, and a number of recommendations for aiding in the work were made. The meeting was attended by J. Walter Drake, chairman of the committee and president of the Hupp Motor Car Corp., and the following export managers: H. M. Robins (Dodge); J. L. Hibbard (Studebaker); Jay Rathbun (White); P. S. Steenstrup (General Motors Export Co.), and R. T. Williams (Overland).

It was pointed out that the United States is the world's market for motor cars and trucks at the present time and that steps should be taken to make this position secure and to extend the sale of American motor vehicles in foreign countries as rapidly as possible. During the year just closed the United States shipped abroad more than 60,000 passenger automobiles, valued at more than \$48,000,000, and 14,000 motor trucks worth over \$30,000,000, not including the cars and trucks bought by the United States government and shipped to our army in France. These 75,000 vehicles, worth \$80,000,000, represent less than 4 per cent of the total production of cars in America and about 8 per cent of their gross value.

It is expected that after the war, when export embargoes and import prohibitions have been removed so that commerce may return to normal conditions, there will be a great increase in the demand for motor vehicles throughout the world and that with proper preparation and cooperative effort between the manufacturers and the government agencies, much new wealth will flow into the country in payment for American materials and labor embodied in more than \$100,000,000 worth of motor cars yearly.

Among the recommendations made by the committee were:

"That the Bureau of Foreign and Domestic Commerce in Washington increase the attention it is giving to investigation of foreign markets for motor vehicles and issue periodical reports relating to the automobile trade in foreign countries.

"That the N. A. C. C. authorize a delegate to represent it officially at the National Foreign Trade Convention to be held in Cincinnati next April.

"That the N. A. C. C. gather information relating to available highway improvement data with a view to sending such material to countries where road construction is in a backward state.

"That the N. A. C. C. undertake the preparation of a table of equivalents in foreign languages for standard technical automobile terms."

By invitation, Tom O. Jones, special agent appointed by the Bureau of Foreign and Domestic Commerce to investigate the market for motor vehicles in the Far East, attended the meeting and told of some of the conditions he observed in Japan, China, the Philippines and Hawaii on the eight months' trip from which he has just returned.

He said that Japan was prosperous and was buying more automobiles than ever before, with large and expensive cars selling well. There are about 2,400 automobiles in Japan now, he said, and during the first nine months of last year 600 had been imported as against 218 during all of 1916. Japanese roads are very narrow and the bridges

weak, but the army is using some motor trucks and the government is spending \$2,000,000 on the road from Tokio to Yokohama and ordered the provinces to improve their roads and bridges. This will open a big market, he said, for motor vehicles. Japanese army engineers brought an American truck over from Tientsin, China, and copies it at a government arsenal, but had so much engine trouble that the idea of manufacturing trucks in Japan has been given up and the government is now buying its trucks in this country.

Owing to the unsettled political situation in China, the Chinese hesitate to buy cars now, Mr. Jones said, because they are afraid they may be taken away from them. There are practically no roads in China outside of the cities and foreign concessions, but the governors of the provinces are beginning to realize that their districts are handicapped on this account and now propose to build roads to connect towns with the railroads. In and around Pekin there are about 150 miles of roads suitable for automobiles. After the big flood last summer the Red Cross raised a fund of about \$400,000 and the government raised an equal amount, which was used to pay coolies to break stone for construction of the road from Pekin to Tientsin. There is a 1,000-mile road from North China into Manchuria on which two light American cars are operated on a regular passenger-carrying schedule and a proposal is on foot to put a fleet of 50 motor trucks in daily service on this route.

Gasoline was selling in China last summer at 84 to 90 cents a gallon, gold, and in Japan during the last two years at 45 to 50 cents.

Medium-priced cars with small motors and short wheel base are required in China and Japan, said Mr. Jones. There are about 2,100 cars in China, of which 1,300 are in Shanghai.

## Seven-Passenger Touring Body

(Illustrated on opposite page)

The design shown represents a seven-passenger touring body. It is a straight-line body with slanting windshield, which adds a graceful and unusual appearance. The body is equipped with second cowl behind the driver's seat, which provides handy locker space on each side and might contain drawer in the center.

Since this car is intended for extended touring, the riding comfort of the passengers has been the first consideration. The cushions and the back of the seat have been set at an easy angle and the seat itself has been dropped low so as to give an unusually high back without impairing the low appearance. The top is a five-bow one-man top. The plan view illustrates clearly the comfortable proportions. This body is mounted on Crane-Simplex chassis.

Characteristics of chassis—Body space, 112½ in.; wheel-base, 144½ in.; wheels, 37 x 5; drop of chassis, 6½ in.; width of chassis, 44 in.; tread, 56½ in.

## Oil Companies Prosperous

The year 1917 has been the most prosperous year in the history of the big oil companies. In the last few months the oil producing companies have produced crude oil at the rate of 1,000,000 barrels a day, the best record ever made. The country's refining capacity of 1,250,000 barrels a day has been increased to meet the greater demand.

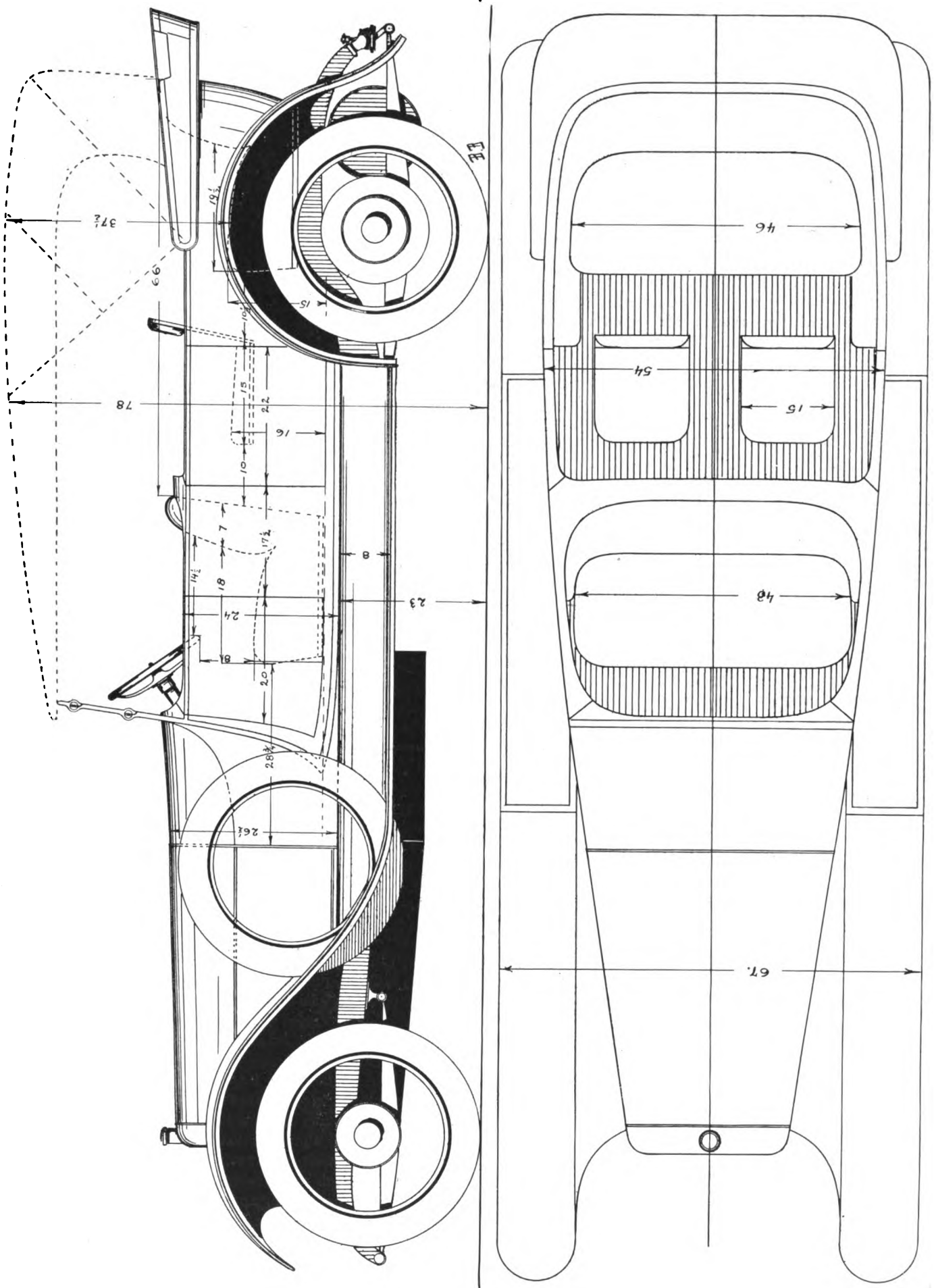

**SEVEN-PASSENGER TOURING BODY**  
Description on opposite page

## The Electric Vehicle Situation

### Considerable Impetus Lent by the War—Gains Permanent—Outlook Bright

By A. JACKSON MARSHALL,

Secretary Electric Vehicle Section, National Electric Light Association, 29 West 39th street, New York City

The electric vehicle is modest. It is quiet. It has not the spectacular speed of its brother gasoline car, although it has a habit of getting there and back in a rational way on scheduled time. It is dependable. Its operating costs are likewise modest. In design, construction and operation it is simplicity itself. It was and is the simple and ready solution of many transportation problems, but like many other apparent and obvious remedies, it was to a measure overlooked for those possessed of spectacular complications which in their mastering required "tinkering," with which oftentimes there is associated a certain degree of fascination. There is, however, not the opportunity—or I might say the necessity—for "tinkering" with the electric vehicle because of its absence of moving parts as the electric vehicle has practically but one moving propelling part and that the rotating armature in the electric motor, without which the world today would indeed be a strange and inactive place.

It has been estimated that approximately \$36,000,000 was invested in electric commercial vehicles at the end of the year 1916. And it is also interesting to note that many concerns employed large fleets, the result of repeat orders placed over a period of years, which in itself verifies success of any equipment.

In passing, it should be realized that these large installations of electric commercial vehicles were not made because of any sentimental leanings, but because exacting engineering analysis of conditions proved that electric vehicles would render the maximum degree of satisfactory service. And it will be readily appreciated that this represents an endorsement of no mean proportions which has paved the way for greater recognition which was to come.

#### Relation to the War

When the war broke out about three years ago, a great change began to come over the ordinary ways and means of maintaining life in general, and one of the many phases of industry which early felt the influence of war was that of transportation, and we have records of what has happened in the interim, especially in England. At the outbreak of the war England had in use about 150 electric commercial vehicles which had been installed during the preceding period of about ten years, representing an average yearly installation of about 15 vehicles—certainly nothing over which to wax enthusiastic. As gasoline became scarcer and more expensive, increased consideration was given to the electric vehicle, for did not England possess right in her own land well nigh inexhaustible supplies of coal through the medium of which electric current could be generated at comparatively low cost in practically unlimited quantities? Here was a source of power on which England was not dependent on importation. There were no U-boats to consider in the mining of coal, and, furthermore, no valuable shipping facilities were necessary to make such power everywhere available.

So the electricity supply companies throughout England made investigations, resulting in numerous electric vehicle charging facilities being made conveniently available, and they furthermore offered this charging current in

many instances for what in our money would be about two cents per electrical unit.

Installations of electric commercial vehicles followed in rapid order and users early realized that results were even more satisfactory than they anticipated. Naturally such favorable operation exercised no little influence in causing others to investigate the merits of the electric vehicle and ere long the demand proved greater than the supply, which was to a measure naturally dependent on importation as local manufacturing facilities had not kept pace with the advance.

#### English Conditions

These new English users of electric vehicles learned from experience that their operating costs were considerably lower than for those obtaining for gasoline, steam and horse-drawn trucks, and that the electric vehicles were the acme of dependability. Furthermore, their simplicity of design and operation enabled them to be readily driven by inexperienced men. Finally, as men of all ages became more and more scarce, women drivers were tried as an experiment and they made good. Today one of the largest stores in London operating some 60 to 75 electric trucks, use women drivers almost exclusively. This represented a very significant development which the government authorities have not been slow to appreciate.

Volumes could be written on much interesting detail associated with the success of the electric commercial vehicle in England and particularly these last three years, and the very likely developments which the next few years will witness. It might, however, be interesting to note that whereas England had but 150 electric trucks a little over three years ago, today about 1,000 are in operation and many more are on order, and were it not for the lack of transportation facilities, these figures would be considerably greater. To give a clear idea of the actual gain, advise that the yearly rate of electric truck installation three years ago was about 15, whereas the average yearly rate the past three years has been about 300, with the present yearly rate about 500. But the rate of increase has by no means yet reached its stride, and during the coming few years, even if war should continue, the writer would not be surprised to see many thousand of these utility vehicles installed. And what is even more interesting, every electric vehicle installed will not only remain permanent, but by virtue of its successful operation will influence large additions.

#### Electric Industrial Trucks

While the success of the electric commercial vehicle has been marked, the success of the little electric industrial truck, if possible, has been even more so, and today great numbers of these units are rendering most efficient and valuable assistance in hundreds of manufacturing plants engaged in making munitions and in the more peaceful commodities. In many instances these small electric trucks are also being operated by women who experience little or no difficulty in rapidly familiarizing themselves with the trucks' simple construction and control. It, therefore, will be seen that not only are these trucks doing yeoman duty (each truck releases on an average of about five men for other important work) in speeding up and transporting the vast quantities of materials employed these days, but they are also making it possible to fully and gratefully utilize the services of women, without whom the world today would be less safe.

**Electric Passenger Cars**

Likewise in England we find a greatly increased use of electric passenger cars, which in many instances are employed in important work far removed from what we ordinarily might consider as pleasure. When it is realized that the electric passenger vehicle more than successfully competes with the gasoline car in urban territory, with gasoline at from 12 to 15 cents a gallon and electricity at about five cents per kilowatt hour, the immediate importance and value of the electric passenger car is considerably enhanced, for gasoline (when procurable) now costs in England about \$1 a gallon and electricity about two cents per electrical unit.

Besides the simplicity of the electric vehicle is such that no chauffeur is required, and as repairs and adjustments are very infrequent and, when necessary, can readily be made, expert mechanical supervision and tinkering are reduced to a minimum, which not only practically eliminates man labor but the use of mechanical parts so needed in other fields of activity.

In Norway and Sweden electricity is plentiful and cheap largely on account of great water power developments. On the other hand gasoline is almost impossible to obtain at any price, but when procurable costs upwards of \$1 a gallon. In these countries vast electric vehicle developments are pending and already large installations have been made which are operating in a most satisfactory manner. Were it possible to freely obtain export permits and shipping facilities to these countries, great quantities of electric vehicles of all types would be rapidly purchased and installed. Ultimately electric vehicles will be made available in Sweden and Norway in unlimited quantities either by importation or local manufacture and then electric vehicles will rapidly become the national mode of mobile transportation.

**Electrics Gaining in Italy**

In Italy the electric vehicle has somewhat more recently been recognized and plans are now being perfected whereby the electric power generated by Italy's waterfalls will be utilized extensively in supplying the propelling force for large numbers of electric vehicles. One of the electric vehicle promotion schemes now maturing is a large and representative touring exposition of electric vehicles which will be displayed and described in such a way as to educate the people to the advantages of this form of locomotion, especially as by such Italy is able to capitalize on her water power development which, to the extent of the development of the electric vehicle industry, will make her independent of the importation of gasoline for the operation of such type of vehicle.

In far-away Australia and New Zealand, in South Africa, Japan, Mexico, South America, Denmark, France, and, in fact, all over the world, electric vehicles are now being exported in increasing numbers, and everywhere we find great interest being manifested in what is quite likely to eventually prove the ultimate and dominant form of mobile urban transportation—the electric vehicle.

**Conditions in Germany**

It may not be generally known that the electric vehicle had made great headway in Germany prior to the outbreak of the war and that during the last three years the electric vehicle of all types has played an important part in Germany's existence. Electric taxicabs in Berlin before the war gave the highest class of such service available and

these electric taxicabs were considered by the municipal authorities as worthy especial consideration, which was extended.

In the United States (in Detroit) the highest class of taxicab service is rendered by electric taxicabs, likewise in Chicago and St. Louis. We do not know very much about what is actually transpiring in Germany these days, but fragmentary reports all indicate that the electric vehicle, even in the face of all the general destruction which prevails, is taking an even more commanding position in the transportation field, where it is employed on the streets of the cities, in the coal mines, in the form of electric railways and for trackless trolleys; which are likewise proving such a success in England.

Foreign countries have had a very satisfactory experience with electric vehicles, especially these last three years. These countries will even more extensively use electric vehicles after the war and with the return of more normal times, especially during the reconstruction period of many years' duration, which will follow. The thousands and thousands of electric vehicles required will to a very large measure be supplied by American manufacturers whose facilities will be taxed to the limit. Therefore, looking beyond the cloud that at present darkens the horizon, we see tremendous demands which will keep us all busy for many years to come.

In addition to this foreign business, existent and prospective, there is the constantly growing domestic demand which gives promise of even greater increases as we progress with the war for goods in greater volume than we have ever known must be transported and transported far more rapidly and efficiently than ever before.

Not only will motor transportation be more extensively used in this country than ever before, but it is going to be used much more intelligently and efficiently, which naturally will add to its value and popularity.

**Pending Developments**

The war, with all its horrible toll, is proving to be a great corrector and the many lessons we learn from it will serve us for years to come. Many of the existing transportation defects have been apparent for a long time to a comparatively few whose business it was to know, but the war is so strongly emphasizing these deficiencies that it is becoming an easy matter to gain public support for the changes that must come and come quickly.

The public, including a large percentage of transportation users, will be greatly surprised as to the character and extent of changes which will be effected in the matter of transportation, but for the most part they will be to the best interests of all concerned and to a large measure will remain permanent, at least until we become further advanced.

In summary, it is believed that even although we are confronted with unprecedented conditions which momentarily will throw out of balance usual modes of activity, the future holds vast possibilities for motor transportation and consequently the motor car industry will enjoy a success which will dwarf its present Aladdin-like growth.

**Blackley to Direct Larrabee-Deyo Sales**

B. E. Blackley has resigned as general sales manager at the Chase Motor Truck Co., of Syracuse, N. Y., to direct the sales and advertising for the Larrabee-Deyo Motor Truck Co., of Binghamton, N. Y.

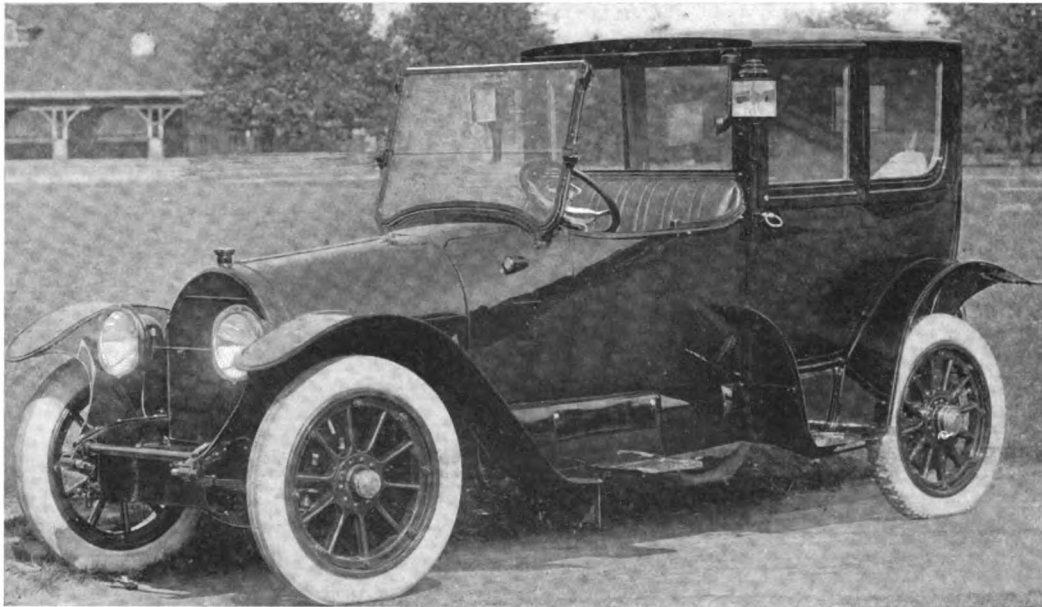

**TOWN CAR**

Body by The Rubay Co., Cleveland, O. Mounted on Cadillac Chassis

Note the old carriage style of fenders. Roller curtain is concealed in the front part of the roof and can be attached to the windshield to protect the driver when pulled out.

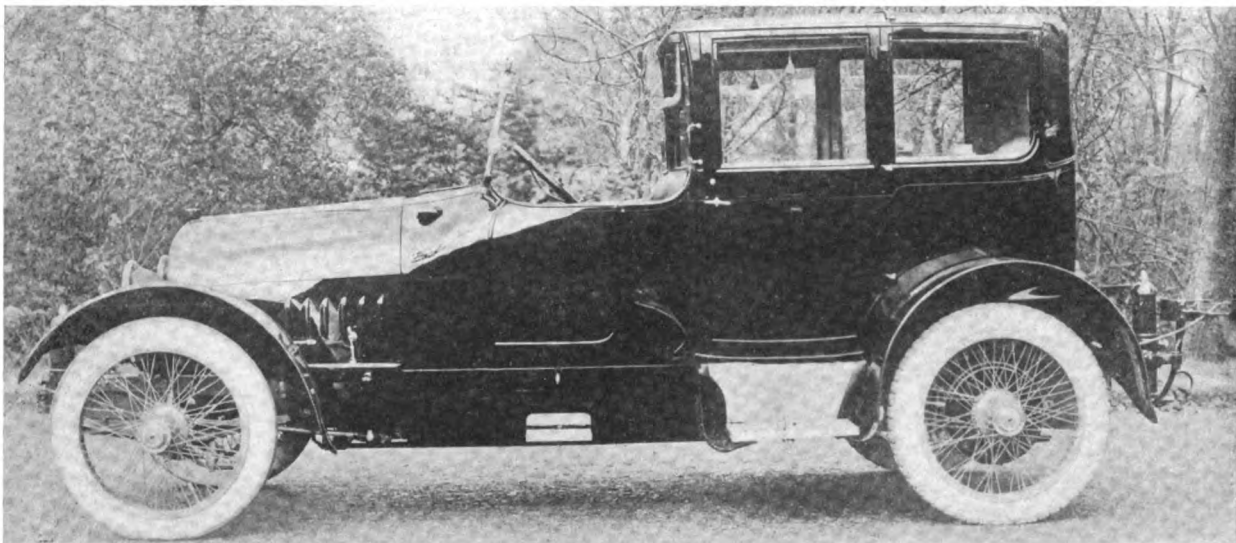
**LANDAULET BROUGHAM**

Built by Daniels Motor Car Co., Reading, Pa.

This is a regular Daniels "8" stock car and was exhibited at the New York Salon. Note the individual steps.

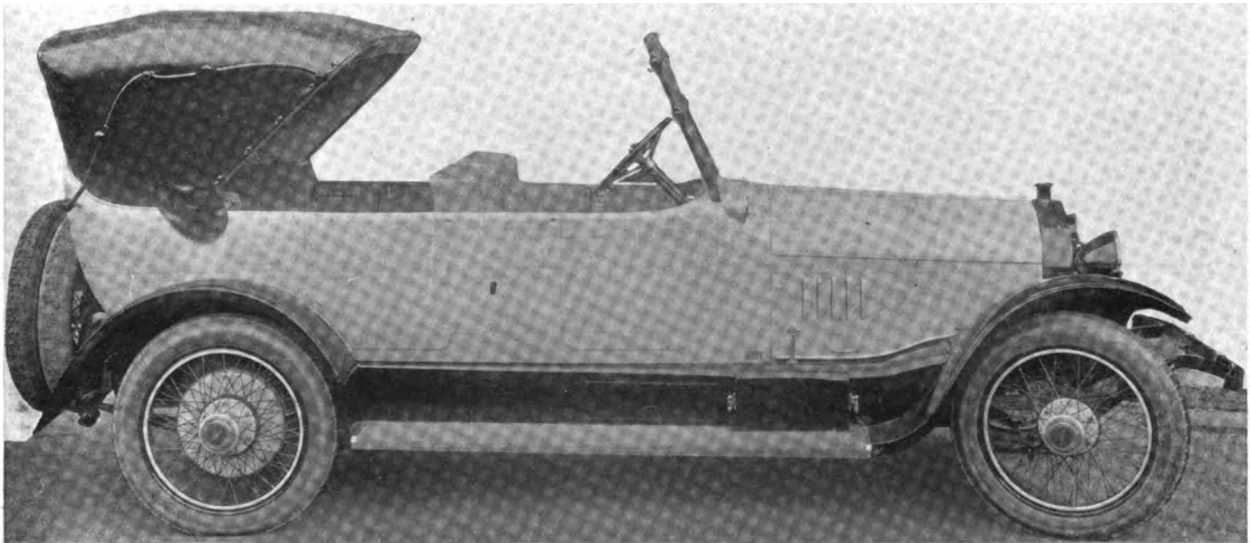

**SEVEN-PASSENGER TOURING CAR**

Body by The M. Armstrong Co., New Haven, Conn. Mounted on Marmon chassis  
Front seats trimmed in light gray leather; rear seats in waterproof cloth.

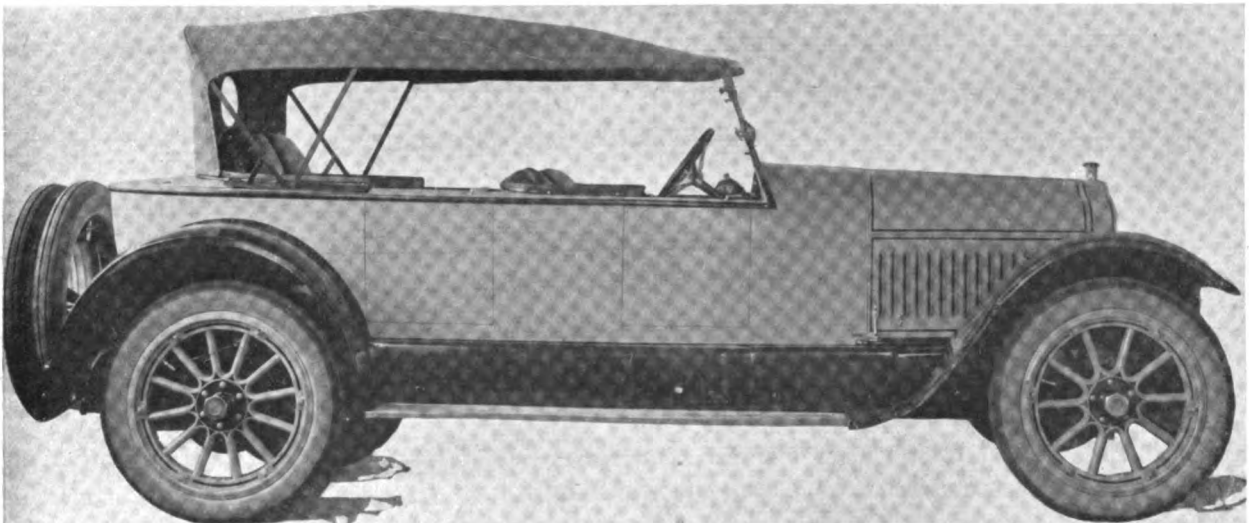

**SPECIAL BOAT BODY**

Built by The Rubay Co., Cleveland, O. Mounted on White chassis  
The top disappears when down in a compartment especially built for that purpose around the back seat

### Heat-Treatment of Automobile Parts\*

The art of improving steel by heat-treatment was known and used by a few men for quite a number of years, but it has been considered a commercial manufacturing possibility only in recent years. As the benefits and significance of heat-treatment became recognized, research and progress in all subjects closely allied with the treatment of steel were stimulated. The results of this stimulation were better furnaces to produce the steel, different steels, and many radical changes in the design of machine tools. We have only to go back 15 or 20 years to realize what this progress has been. The writer can recall one time when a gear hob 6 in. in diameter and 8 in. long had to be hardened. With the aid a few firebricks, an oven was built in the coals in the smith's forge, which was in a dark corner of the shop, the hob was put into this oven, and the blast turned on. When the human pyrometer guessed that the hob was hot enough, it was pulled out and hung on a wire in the same air blast until cool. While we do not know a great deal more about the fundamental principles of heat-treating than our fathers did, more people know these principles, so that today there is a special kind of steel for almost every purpose.

Few men, other than the designing engineers, have any idea of the number of steels there are and the great variety of treatments these steels receive. For instance, in one automobile the wire-wheel hubs are drawn up from special, soft, deep-drawing low-carbon steel, and finally given a treatment to bring the steel to condition after drawing. Vanadium steel may be substituted for this deep-drawing steel before long. The wire-wheel spokes are a high-carbon steel drawn down with extra care and set up cold. The steering knuckle and arms are 0.28 to 0.35 per cent carbon, chrome-vanadium steel, and are treated to have about 105,000 pounds tensile strength. The knuckle ball cups and races are of 0.15 to 0.22 per cent carbon chrome-vanadium steel and are casehardened to about 75 on the scleroscope.

The front-axle forging is a straight 0.35 to 0.45 per cent carbon steel forging treated to a tensile strength of 100,000 pounds; the center of the beam is drawn back to 65,000 pounds. The ball studs in the knuckle arms are 0.15 to 0.25 per cent carbon chrome-nickel steel and are carburized. The cross-tie rod tube is a 0.25 to 0.35 per cent carbon 3.5 per cent nickel-steel tube and is heat-treated. The springs that fasten the axle to the frame are of 0.42 to 0.52 per cent carbon chrome-vanadium steel and are heat-treated. The frame itself is from hot-rolled sheets about 0.12 to 0.20 per cent carbon; special attention is given to sulphur and phosphorus to allow of cold pressing.

Practically all the levers, pedals and small brackets on the chassis are drop-forged from 0.25 to 0.35 per cent straight carbon steel and are heat-treated so as to have an average tensile strength of about 90,000 pounds. The motor shell is a steel casting of a special analysis and treatment that give it the magnetic properties; the armature core plates are punched from steel sheets especially produced for that purpose. The armature shaft is a 0.28 to 0.35 per cent carbon chrome-vanadium steel and is treated to have a tensile strength of 110,000 pounds. The universal joint forgings are of 0.25 to 0.35 per cent carbon, 3.5 per cent nickel steel, and treated to have a tensile

strength of 100,000 pounds; the pins for these joints are of 0.15 to 0.22 per cent carbon chrome-vanadium steel, casehardened.

The propeller shaft tube is especially swaged from 0.25 to 0.35 per cent carbon steel that contains 3.5 per cent nickel. This propeller shaft revolves inside an especially swaged torque tube made from Mayari 0.25 to 0.35 per cent carbon, 1.5 per cent nickel-chrome steel, and is connected with the pinion shaft, which is made of 0.15 to 0.22 per cent carbon, 5 per cent nickel electric steel, and is especially carburized with one tempering heat. This pinion drives the rear axle gear, which is made of 0.15 to 0.22 per cent carbon, 3.5 per cent nickel electric steel, and is especially carburized and tempered in a Gleason tempering machine. Inside this driving gear are the different gears made from drop-forged 0.15 to 0.25 per cent carbon chrome nickel steel and carefully carburized. Exactly what is the strength of either the driving gear or the differential gears it is impossible to say owing to their shape, but destruction tests show them to possess enormous strength and the casehardening gives the spiral gears an almost indefinite life. The drive shafts from the differential to the hubs are of 0.42 to 0.52 per cent carbon chrome-vanadium steel, and are heat-treated to have a tensile strength from 160,000 to 180,000 pounds; the driving flanges at the hubs are of 0.25 to 0.35 per cent straight carbon steel and are heat-treated to have a tensile strength of about 100,000 pounds. The upper bracket, which connects the main spring with the chassis, is a 0.28 to 0.35 carbon chrome-vanadium steel forging that has been heat-treated to give a tensile strength of from 110,000 to 120,000 pounds. Even the irons that support the fenders are of 0.28 to 0.35 per cent chrome-vanadium heat-treated steel.

This list shows that there are many different alloy steels to be produced and treated for the manufacture of automobiles; and, in addition, there are many kinds of steel sheets finished in all conditions from dull black to extra bright and having a wide variation of deep drawing qualities. If the mills are required to produce this great variety of steels for the automobile trade only, how much more must they have to do to take care of the locomotive, rolling stock, rails, construction work, ammunitions, guns, armor plates, shipbuilding, electrical engineering, airplanes, and every other business using any form of steel? Many people tell us that the war in Europe will be won with airplanes, but, indirectly, heat-treating will win the war, for the success of the trucks, automobiles, air engines, guns, ammunition, etc., depend upon successful heat-treating of the steel used in the construction of these articles.

### Kettering Is S. A. E. President

At the annual business meeting of the Society of Automotive Engineers, held in New York, January 10, C. F. Kettering, vice-president of the Dayton Engineering Laboratories Co., was elected president, David Beecroft vice-president, and C. B. Whittlesey, vice-president of the Hartford Rubber Works Co., treasurer. Representing the various interests of the society there are five second vice-presidents: C. C. Hinkley, of the Hinkley Motors Co., representing automobiles; G. H. Houston, aviation; Fred Glover, vice-president of the Emerson-Brantingham Co., tractors; H. R. Sutphin, vice-president of the Submarine Boat Corp., marine engines; and H. R. Brate, farm and stationary engines. New Members of the council are C. M. Manly, J. V. Whitbeck, and C. S. Crawford.

\*Extract from an address delivered before the Steel Treating Research Society, of Chicago, Ill., by Arthur W. Medhurst, assistant general manager of the Anderson Electric Car Co., of Detroit, Mich.

# Comments on the Two New York Shows

After having decided to "show as usual" the automobile makers organized their efforts to the end that there should be displays of the customary excellence, and as usual, they succeeded.

"The Automobile Salon" was installed at the Hotel Astor, just as always. We have wondered in a mild way why a place should be selected that compelled the exhibits to be shown in a "dim, religious light" both day and night. If an automobile were a dolled up beauty we could understand why a soft, not too searching radiance, would be the proper kind of light, but a car ought to be in a light that would aid the most painstaking examination. Taking one consideration with another the Salon (!) is not a good place for a merchant to display his wares; neither is it good form for the merchant to have his salesmen slipping about at night in evening clothes as demonstrators of merchandise. These are the first impressions of an observer.

The catalog of the wares was inappropriately beautiful. It was arranged without order and contained much extraneous matter, just as if the idea was to impress with anything so long as it was pictorial and full of color. It was an injustice to the exhibitors. It cost a dollar and ten cents to receive a catalog and a ticket of admittance.

There were twelve exhibitors of cars and two of car bodies, but the car body makers were more in evidence than this, as they had examples of their work on the exhibited cars, and in most cases a special representative to tell about the merits of the body work. There were also seven exhibitors in the accessory class. All in all, a very select assemblage, but rather too exclusive, too dim, and too few walking about with eyes, ears and words displaying a buying interest. The prices, of course, acted just as does a high protective tariff.

A general impression on a walk-around is one of too much sameness in cars that depend on distinctiveness to justify the price.

The next outstanding impression is that builders ought to get together in the interests of a correct and standardized nomenclature as applied to the tonneau. Some of the mix-ups of names that are coupled and split and then given to the body of the vehicle are not even amusing, they are so conglomerate; also there is no general rule in the goulash of terms. Decidedly, the builders could amend this.

Suppose we go to the Rolls-Royce first as an international amenity. If we name the entire exhibit we should catalog four cars and two airplane engines. The latter were at ends of the large ballroom and were taken from airplanes that had been "brought down," so that gave us a chance to see and examine the engines. They were very interesting, but not illuminating to the writer because he has to have his wits about him to grasp the details of a spic and span new engine. The chassis, we understand, were gathered up in this country from users, painted up and furnished with bodies that were examples of the work of Barker, of London; Hooper, of Liverpool, and Brooks-Ostruck, of New York, so they were truly international in one respect.

Here we saw the swing in the taste for angular effect as opposed to the sweeps and curves that have made everything so very rounded in contour up to time present. It is the change in fashion that sells things, so it is only a matter of determining if the new designs are made as agreeable as the character of the style will admit of. We think the answer must be yes. In these English bodies the angles are treated with pleasing skill. The hood, for instance, doesn't look just like an "indestructo" trunk, but runs nicely into the straight lines of the body. The American example held its own by comparison. There were the inevitable salamanca, limousine, landau and touring examples, so it was only necessary to see how very prettily the interior was treated in the matter of trimming, and the various little tricks that must be in evidence on the car to appeal to those who see value from such matters about the first thing. The enclosed cars have cloth where it should be and leather for the use of the driver. As a matter of technic the trimming work in most of the cars was just as good as the best of skill could make it. Light

## Cars Cost More This Year, But Moderate Prices Still Prevail

Owing to war conditions and the higher cost of labor and materials it has been necessary to advance automobile prices, but it is interesting to note that the 1918 prices average about \$100 less than the rates three years ago. This year's prices range from \$445 to \$8,000, represented by the following models:

	Cylinders	Price Range
Seven-passenger touring cars.....	4, 6, 8, 12	\$1,295 to \$6,500
Six-passenger touring cars.....	4, 6, 8, 12	2,750 to 5,000
Five-passenger touring cars.....	4, 6, 8, 12	635 to 6,400
Four-passenger touring cars.....	4, 6, 8, 12	695 to 3,750
Two-passenger roadsters .....	4, 6, 8, 12	445 to 6,400
Four-passenger roadsters .....	4, 6, 8, 12	695 to 6,400
Limousines .....	4, 6, 8, 12	2,325 to 6,800
Broughams and town cars.....	4, 6, 8, 12	2,450 to 7,600
Convertible coupes .....	4, 6, 12	1,050 to 2,800
Convertible sedans .....	4, 6, 12	1,050 to 4,000
Landaulets .....	4, 6, 8, 12	2,700 to 6,800
Berlines .....	4, 6, 8, 12	1,095 to 8,000
Coupes and cabriolets.....	4, 6, 8, 12	1,060 to 7,400
Sedans .....	4, 6, 8, 12	850 to 5,900
Open sedans .....	4, 6, 8, 12	1,060 to 4,500
Steam cars .....	2	2,400 to 3,750

cloth with a darkish line giving the impression of a cord was much in evidence, so it must be very popular. We seem to be running into general description from a particular example, but this will answer, we think, because this article is to be one of general impressions. It is not to be a catalog of the show.

The Daniels Motor Car Co. had a very inviting space, because you almost ran into it from one of the entrances. Here were five quite handsome cars.

The star was a landalet-sedan. (I don't know if I ought to make a Siamese twin of this name by using a hyphen, because I never saw the two together before), but the car was very fine. The angular lines were in evidence all over, the painting was military in color, and the spoke wheels carried steel discs that covered the wheel up to the rim, so the military fancy was a harmony in all details. Inside trim was cloth of a somewhat khaki color, and the driver's exposed seat was upholstered in leather.

A collapsible brougham (funny name) was a very fine car for town use. The writer picked it as his favorite.

## Figures Relating to the Automobile in All Its Phases

Figures to show the magnitude of the automobile industry, including the capital involved, the cars in use and the labor employed, have been compiled from various sources by Alfred Reeves, general manager of the National Automobile Chamber of Commerce, in connection with the Automobile Show in Grand Central Palace, New York. They prove better than can be done in any other way the appreciation by the public and business men of the transportation facilities supplied by passenger cars and trucks, which are doing such great work in this country by relieving the railroads of short haul freight and passenger traffic.

### Motor Car Manufacturers

Motor vehicles manufacturers in United States..	550
Commercial vehicle manufacturers.....	372
Passenger vehicle manufacturers.....	238
States in which factories are located.....	32
Capital invested .....	\$736,000,000
Workers employed .....	280,000
Wages and salaries paid during fiscal year ended June 30, 1917.....	\$275,000,000
Motor vehicles produced in last fiscal year.....	1,806,194
Passenger cars produced.....	1,693,994
Commercial cars produced.....	112,200
Wholesale value of vehicles produced during last fiscal year .....	\$917,470,938
Paid for parts and materials by automobile manufacturers during last fiscal year.....	\$480,000,000
Production passenger cars in calendar year 1917	1,795,840
Production commercial cars in calendar year 1917	181,348
Average price of passenger cars produced in 1917	\$720

### Body, Parts and Accessory Makers

Number of concerns manufacturing some article used in automobile trade.....	6,789
Body, parts and accessory makers in United States .....	1,080
Capital invested by body, parts and accessory makers .....	\$336,000,000
Automobile tires manufactured during fiscal year ended June 30, 1917.....	18,000,000
Value of tires manufactured in last fiscal year..	\$450,000,000

### Dealers, Garages, etc.

Total dealers, garages, repair shops, etc., in United States .....	46,000
Automobile and truck dealers in United States	27,800
Garages .....	25,500
Automobile repair shops.....	13,500
Tire vulcanizers .....	12,000
Automobile supply houses.....	2,550
Jobbers of automobile supplies.....	282
Capital invested by dealers, garages, etc., estimated at \$4,000 each.....	\$184,000,000
Workers employed, estimated average of five each .....	230,000
Wages paid, estimated at \$800 per man.....	\$184,000,000

### Automobile Exports

Value of automobiles, trucks, engines, tires and parts exported twelve months ended June 30, 1917 .....	\$133,411,217
Number of passenger automobiles exported last fiscal year .....	64,834
Value of passenger cars exported.....	\$48,620,928
Number of commercial cars exported last fiscal year .....	15,977
Value of commercial cars exported.....	\$42,337,315
Value of automobile engines, tires and parts exported last fiscal year.....	\$42,452,974

### Motor Vehicles In Use

Motor vehicles registered in United States.....	4,842,139
Motor vehicles in New York state.....	418,000
Motor trucks in use in United States.....	435,000
Tons of goods hauled yearly by trucks (estimated) .....	1,200,000,000
Value of passenger service at railroad rate at 2 cents per mile.....	\$1,152,600,000
Number of persons in United States to one motor car .....	24
Number of persons to one motor car in eleven middle west states.....	17
Number of persons to one motor car in eleven eastern states .....	26
Percentage of cars sold to farmers in 1917 (estimated) .....	40
Number of automobiles in United States to each mile of public road.....	1.72
Number of automobiles in United States to each mile of surfaced road.....	14.77
Number of automobiles in United States for each square mile .....	1.4
Automobiles in use in all countries outside of the United States January 1, 1917.....	719,246

Added distinction was given by the absence of running board, the individual steps being liberal in size and well placed and supplied with mats which would overcome slipping.

There was also a suburban, four-door, car that filled the bill, and a roadster that had a dickey seat that could be jumped into place and made to disappear with just the least effort. Wire and wood wheels were both used to give a choice. The painting of all bodies was in dark tones and most agreeable in combination. Green, black and brown. These Daniels bodies, we suppose it is quite well known, come from the work rooms of the Keystone Body Co., so it is superfluous to dwell on a high quality that about everyone is aware of.

The next in line was the show of the Murray Motor Car Co., from Pittsburgh. Probably the writer could give a somewhat ordered description of the exhibit were it not that he was auto-intoxicated with the sight of the touring model that was so very angular that it was positively cubist. Nothing better than this car could illustrate the tendency to run to the very extreme of anything new. If there was an angle acute, obtuse, indiscreet or impertinent that this car does not contain, you would have to go to Euclid to find out what it was and to name it. The body was unpainted, the wheels were dished, and I overheard the salesman say that a gentleman had actually bought the car. Wonder if the home of the gentleman was also in Pittsburgh. There was an inside-drive coupe that made amends, however, showing that the builders were merely catering to the extreme in the cubist car.

Lancia & Company, Turin, say that Mr. Thomas Evarts Adams, not plain T. E. Adams, is the sole "concessionnaire" for America, but be that as it may, this is a fine car and there were six of them to choose from on the main ballroom floor. Most of the bodies were by Lock and by Hays & Miller. Peter M. Martin, who in the long ago was the best man with J. B. Brewster & Co. (of 25th street), was the representative of Lock & Co., so it was quite like the old carriage days of the better sort. Lock showed town brougham, cabriolet and small limousine. Hays & Miller were represented by a touring body and a roadster. It is very interesting to note how the real coach body builder can adapt himself to the new order, and make it harmonious and beautiful. The Lancia bodies and chassis looked money's worth.

The White Company, of Cleveland, had eight cars on show. All the bodies were signed by Rubay, and they were very pleasing indeed. There was anything you might want from a town cabriolet to a bizzarrette. There was nothing so distinctive about the finish or trim that mention may be particularly made, but the lines of the bodies, were in the prevailing fashion so harmonized that they did not look too very angular, but just enough to give an air of grace to the effect. (These words do sound just a little cubist, too, but they have to be used this way once in a while). The distinction of the White so far as the power unit is concerned is that with its system of valves it makes its four cylinders do what the other fellow's twelve does, and then some.

James Cunningham, Son & Co., of Rochester, had five examples of the work of the factory on view, to wit: Runabout, touring, inside-drive limousine, town car and cabriolet. We hope to have the chance to show illustrations of these cars to readers if the prints reach us in time. The Cunningham work is very thorough from top



to floor. No details are missing in the trimming, and the painting is done in a way to satisfy even a carping critic. The lines of the work followed the general trend, as it had to do if you build cars to sell—and that is what makes a description of this kind so difficult as it gets along toward its finish.

Now we come to the Fageol, all the way from California.

This car has a six-cylinder, Hall-Scott aviation motor built into its power plant, which makes its distinction, we suppose, as the body design on the one car shown would not attract us like a magnet.

The Simplex (Crane model) was a thing of beauty.

Space will not admit of a too extended account; anyway it would be but a variation of a theme that could be sounded too often, so we will get to the star exhibit of the show without further ado.

Brewster & Co. had four cars in its very prominent space when we saw them. Each one was distinctive. A town brougham was built after the lines of the old-time Brewster brougham, in the days of the horse, not even the dickey seat, skirt leather with silver mounting, etc., were missing.

The cane work on the panels of the body was what our French friends would call a tour de force. It was hand painted, stood out like real cane, had none of the crowded, stuffy look of the usual applied work of the kind, and was very pleasing in its effect. This car body very nicely indicated that the skill and taste of the body builder, as formerly developed to such refinement is quite applicable to a motor car, and that it gives it a distinction that is not usually found on these bodies. The car must be shown to be appreciated, and we hope to do that service for our readers.

The real feature that made all the other builders come around and take a good, long look, was a so-called special enclosed-drive phaeton. I suppose this is a perfectly all right name, but it doesn't seem to me so. At any rate the carriage is a perfectly all right example of the chief thing for which the name Brewster, of Broome street, has always been distinguished, that is originality following lines of the most severely correct taste.

This body is in the prevailing angular style, but it is built entirely of wood and the body maker has been able to make the ideas of the draftsman come up like an intaglio. The whole scheme is lightness and grace, with a touch of the prevailing military. Let us go from the ground up instead of the other way. The wheels are a real vermilion and, I think, rubbed down to a dull gloss, the leather mud fenders are built over the wheels only, with just the right curve at the tip to make them please the eye. In place of painting the chassis all black, or all any one color, where the chassis shows under the curve of the fender there is red to match the wheels. Somehow this gives an artillery effect, and anyhow it is mighty fetching to the beholder. The color of the body is a military gray, and it isn't, because there is a glint of khaki color in it that makes it a new color. As these folks always did do stunts with their grinding of colors for paints ever since the old days, that drove the paint makers to distraction to try and duplicate, we suppose they have been at the old stunts, with the usual brilliant success. The effect is fine.

The door inside is of cane, with room at the bottom for dust clearance, a pretty idea in the line of lightness and good looks. The quarters, the back and the top are yellow tint. This top covering is just applied over the top fram-

ing which shows and looks as if that is just the way it ought to look. The inside trim is of a canvas the like of which I never before saw, as it has all the softness to the touch of an unfinished wool.

There is shown on the car a new (and patented) wind shield that is V shaped with the top half glass sliding up and down in a manner that prevents all drafts but affords fine circulation and ventilation. The tops of the body windows have about a quarter of the glass of the window permanently fixed in place, thus giving strength to the body top where it is always needed, while the remainder of the window is forced up by a fair harness leather pull after the old manner, and tight joints by sliding over the outside of this top glass. It is a good idea.

If I go on any further, it will have too much the look of playing Hamlet with only the Dane in the cast, so I will just say this whole job weighs, complete, everything on, but 3,700 pounds, but it costs more than a dollar a pound to own it (\$8,400).

This is about as far as we can go this month.

But just a word about one of the accessory exhibits, that of Laidlaw & Co. The goods were of the various textures for which the concern is justly praised, including the Burbank, Limotex and Vogue seat coverings, but among the samples of the more than 200 cloths from which they can afford a selection, those they displayed were so artistically arranged as to lighting, etc., that it was as good as looking at the very best trimming stunt.

And so we pass out of the "Salon" of 1918.

**Production of Automobiles for the Last Thirteen Years**

(Official figures furnished by the National Automobile Chamber of Commerce)

Year	Passenger Cars Only	Year	Passenger Cars Only
1905.....	33,896	1911.....	209,957
1906.....	52,462	1912.....	378,261
1907.....	67,389	1913.....	450,000
1908.....	85,846	1914.....	515,000
1909.....	125,593	1915.....	703,527
1910.....	175,800	1916.....	1,617,708
		1917.....	1,795,840

**Grand Central Palace Show**

The customary square feet of floor space was well filled with car exhibits and accessories.

The Willys-Overland had the point of vantage, which I believe is accorded on the basis of sales at the show of the previous year, but that's a mere detail. The space was well filled with well-appearing cars, but the much advertised new departure very low priced car was the magnetic center of attraction. The crowd was curious, inquisitive and very much interested.

The chassis was displayed stripped, and the unfinished metal body rested on supports beside it. The salesmen were much questioned about price, but were unable to answer the leading question just yet.

The chassis was most interesting on account of the way the springing had been worked out. It is not very satisfactory to attempt a description without illustrations, but you can figure to yourself the rear of the chassis in bent,

one piece rounded form extending well to the rear of the axle. Coupled to the axle by means of shackle clips was a spring that followed the contour of the rear part of the chassis in an obtuse curve. It was fastened at three points, at the axle, shackles, and at the center of the rear of the round of the chassis. I hope this is clear. The front spring was more nearly horizontal, but both were a new application of the half elliptic as a cantilever. As this springing is new, only time can prove it, it would seem. The motor was simplified, the transmission had been blue penciled as much as efficiency would allow, but the crowd was too eager, and close inspection was barred. The body was stamped out in large section, so that a few fastenings would be all that are necessary to put it on the chassis in a complete form, needing only painting, trimming and the minor touches that spell finish. This exhibit, in one respect, was the feature of the show.

Now let us pass to the other general impressions before getting down to particulars.

First, the attendance was large. It would be difficult to estimate the value to exhibitors, but it is a fact that

### New York Auto Show at a Glance

- Total number of exhibitors—346.
- Number of complete cars and chassis exhibited (approximately)—400.
- Number of car manufacturing companies exhibiting—86.
- Number of accessory and parts companies exhibiting—260.
- Six exhibiting companies displayed twelve-cylinder models.
- Twelve exhibiting companies displayed eight-cylinder models.
- Fifty-one exhibiting companies displayed six-cylinder models.

#### OF THESE

- Nine companies make both four and six-cylinder models.
- Three companies make both four and eight-cylinder models.
- Three companies make both six and twelve-cylinder models.
- Prices range from \$445 to \$3,000.

every show space that contained the very new, or very well advertised was at about all times crowded; and questions were in the main intelligent.

The general view of the body work indicated a very close duplication of lines and styles, as was most natural, and a predominance of green and black in the paint.

The inside finish and the trimming were in light gray cloth or leather, or combinations of these as the conditions called for.

There were a number of convertible touring bodies displayed, and these removable tops were much better in finish, fit and looks than any predecessors. They seemed to attract pleased attention generally. The tendency to make an enclosed body a summer and winter type grows stronger as it finds favor. All are familiar with the means used to accomplish it, so comment may stop right here.

There is a disc, a wire and a wood wheel that are in the

public eye. It is no longer the wood artillery wheel as the only choice.

There seems to be coming a preference for the cantilever spring as the popular suspension. It is applied in several ways, over axle and underslung. In only one instance was it found to be fastened to the chassis at two points only, with free play over the axle, where it is commonly found firmly fastened also. In our opinion this last described application of the spring to the chassis is a great advance on all other methods of suspension, and it may become the rule when it becomes better known to the trade.

For the money asked the values in cars at the present time from the ground up is a very great advance over anything previously known in this business. Competition has led to standardization, from this comes refinement of the material and design, and great proficiency in detail. For instance, in the matter of substitute leather for tops and trimming a noteworthy step upward has been taken. It is very near a fact that good leather has been equaled, and it is positive that poor leather has been pushed into the background. Leather trim is no longer a talking point on a moderate priced car; there is something just as good and sometimes better if the highest grade fabrics are used. As for looks you must be expert to bandy an opinion. This all makes for the excellent value we speak about.

The Studebaker car is truly an advance on previous efforts. It has always been a thoroughly good car, but this season it looks like a dollar fifty for a dollar. There is "The Four," "The Light Six" and "The Big Six," the latter (enclosed car) priced at \$1,695. The type is thoroughly new in motors, intermediate transmission, axles, bodies and a lot of accessories. The body finish is splendid, the French pleat upholstery put on right. The painting is green on maroon. In the minor details, like the extension tonneau light, for example, that may be taken to any part of the outside of the car for use, the wire reeling back into place on the concealed spring reel (do I make this plain?) is one of the many details of worth crowded into the car. As to the motor, the feature is the hot spot manifold.

The Maxwell calls its combination top "All-Weather Tops," claiming distinction from all others of the alleged same kind because it is not a "makeshift." When on it is a unit part of the car. It is clamped to touring or roadster bodies in a tight perfect fit. The back windows are glass, but those over the doors of a "glasslike material," and these can be raised to any height, so you can have the open effect. The examples shown were of the standard styles, the finish very nice; and remember this car is priced at \$885.

The Reo Six, seven-passenger, was a very fine example from any angle. The 126 in. base is ample for comfort. The Reo engine has always delivered the power, so further comment ends here. The body has divided front seats, disappearing spare seats folding flush into backs of front seats, all the useful little accessories, and very luxurious seats. The trim is leather. Body "golden olive." For \$1,550 this is a fine car.

Such a good car as the Velie was dreadfully handicapped by about the worst color combination in the painting that could be thought of. It was a pity. The body styles, trimming, etc., were in line with the average standard and call for no especial comment.

Let us say here that many meritorious exhibits must

go minus mention just because, like Velie, they conform so closely to a generally recognized standard that they are featureless for descriptive purposes, but very worthy for every use for which they are intended. What stands out in a car somewhat away from the standard, or something very freakish like a car with a canopy top of woven cane, wicker cane-bottomed chairs for seats in the body, and other garish features very nice for a circus, probably. There were, unfortunately, several in this category, but mention of one is enough.

The Marmon is such a fine car mechanically that it is superfluous to take account of details. We notice the touring bodies are wider and deeper (or higher), the rear seat having a 49 in. depth. There is an adjustable foot rail that shifts to two positions. The rear is lighted by electric lamp on back of front seat. It lights automatically by opening the door. The trim of the open bodies is hand-buffed grain leather, and color may be selected to conform to color scheme in special jobs. The upholstery is flush on the inside of body; it does not roll over edge. A very

ing of the rear seats that set the angle at fully 90 degrees from front to back. Once you get wedged into such a comfortable nest you would never reach around for foot braces, but you might need assistance in rising.

There were two "steamers," the Stanley, oldest in the field, and the Doble-Detroit. Both drew crowds. The Doble touring body holds the same good form as any car. The boiler and engine plant does not modify it in any manner. The doors, we noticed, were outlined in square effect by strips, but nothing else was angular. The crowd about the Stanley made it impossible to examine anything, or to come away with an opinion.

There were a goodly show of electrics by the usual makers. The body work sustained the idea of elegance such cars give. This year there was more indication of a plan to follow ordinary design in the matter of the hood, which was an improvement on the runty, snubbed effect that was so general and is not yet a thing of the past.

There is only to add that the angular effect in design, much in evidence in the top rail, also quarters of bodies, made its appearance in many places in the show, and will be more prominent later. It is the approaching fashion.

**Automobile Imports of U. S. Since 1908**

**Commercial and Passenger Combined**

Twelve Months Ended June 30

	No.	Value
1908.....	1,045	\$2,500,134
1909.....	1,634	2,905,391
1910.....	1,473	2,851,446
1911.....	888	1,898,843
1912.....	963	2,134,181
1913.....	748	1,759,380
1914.....	300	620,493
1915.....	322	525,303
1916.....	1,474	801,911

superior limousine car, body by Rubay, was the feature of the exhibit. A distinctive feature is light weight, and a low-hung body. The cloth trim matches the finish, and lifts, etc., match the upholstery. All the polite necessities are included. We cannot go to greater detail in this kind of sketch article.

The F. I. A. T. was another car in the aristocrat class, but placed poorly to show to good advantage its real worth. When we were in the space we were unable to examine the car, because its interior was ungetatable, and there was no one in attendance.

The Franklin was represented by three models. We noticed no especial variation in body design from previous fine models. This company has always had a draftsman whose taste is impeccable, and the work shows for it. There is never any departure from approved good taste, and never any breathless haste to copy "the very latest thing" in fashion; result: subdued elegance. The body painting is worth going to see at any time. It is very superior and the colors are the last word in good taste. We saw nothing new in the sense of bizare in the trimming.

The Saxon is a much improved car in looks, and somewhat higher in price. But the features were nothing more than the average commented upon elsewhere.

The Kissel made a fine showing in the average line. We noticed particularly an arrangement of the upholster-

**Cars Exhibited at New York Show**

Abbott-Detroit	Grant	Oakland
Allen	Hackett	Ohio
American	Hal	Oldsmobile
Anderson	Harroun	Olympian
Apperson	Haynes	Overland
Auburn	Hollier	Owen Magnetic
Austin	Hudson	Packard
Baker	Hupmobile	Paige
Briscoe	Inter-State	Paterson
Buick	Jackson	Peerless
Cadillac	Jordan	Pierce-Arrow
Case	King	Premier
Chalmers	KisselKar	Rauch & Lang
Chandler	Kline Kar	Regal
Chevrolet	Lexington	Reo
Cole	Liberty	Roamer
Columbia	Marmon	Saxon
Crow-Elkhart	McFarlan	Scripps-Booth
Davis	Maxwell	Standard S.
Detroit Electric	Mercer	Stanley
Doble-Detroit	Milburn	Stearns Knight
Dodge Brothers	Mitchell	Studebaker
Dort	Moline-Knight	Stutz
Elgin	Monitor	Templar
Elcar	Monroe	Velie
Empire	Moon	Westcott
Fiat	Moore	Willys-Knight
Franklin	Nash	Winton
Frontmobile	National	Woods

**The 1918 Car**

The 1918 car is bigger in length and proportions, has more power and costs more. Less than 6 per cent are priced below \$750, as against 10 per cent in that class last year.

Only 21 per cent of this year's models sell at less than \$1,000, while last year nearly 28 per cent sold below that figure. A year ago about 53½ per cent of the models were

priced between \$1,000 and \$2,000, while this year only 49 per cent are included in that class.

Cars are more comfortable and more efficient than ever this year. The principal way in which they have been made more comfortable is that there is more room in the driving compartment. It is not necessary to go through the various contortions formerly required in order to enter the left front door of a touring car, because, in general, the steering wheel has been given much more clearance between the edge of the door and the front edge of the seat.

The closed car roofs are flat and level; the touring bodies are rectangular, without a break in the straight line effect from the front of the radiator to the rear of the tonneau, accentuated with a bevel edge along the rail. The hoods of cars are higher; the doors wider, the seats wider and better upholstered, so that in comfort as well as appearance the car of 1918 is an improved product. The upholstered springs in the front compartment are also better than formerly and the persons riding at this end of the car have just as good upholstery as those in the back. The average driver is the owner of the car, and therefore must be taken good care of if he is to maintain the same high opinion of motoring as his passengers have.

A general increase in wheelbase is noticeable, the average length this year being 120 $\frac{3}{4}$  in., as against 113 $\frac{1}{4}$  in. a year ago. The Trumbull has the shortest wheelbase listed this year, 80 in., while the Pierce-Arrow presents the longest, 147 $\frac{1}{2}$  in.

Another mechanical change is the enlarged engine size, the average piston displacement now being 269 cubic in., compared with 222 cubic in. last season. There are more valve-in-head motors and more equipment. More cars are also supplied with thermostats as economizers of fuel.

Probably the most talked of feature of 1918 engines is the so-called "hot spot." The name is self-explanatory. With the hot spot a portion of the intake manifold comes in direct contact with the exhaust manifold, giving an unjacketing wall between the two. As the intake gases enter the cylinder they must come in contact with this heated wall in the exhaust manifold, with the result that any globules of fuel which have remained unvaporized up to this time come in contact with the hot wall and are immediately boiled and changed from a liquid condition into a vapor which is easily ignited.

There is a marked trend in favor of the ignition systems of the secondary distributor type.

In spring suspension there is a decided tendency shown this year in favor of the half elliptic, this type being used on 38.7 per cent of the makes, while last year it was used on 35.5 per cent. The three-quarter elliptic type, which was used last year on 27.8 per cent of the cars, is used on only 24.2 per cent this year, while the cantilever is used this year on 29 per cent of cars, as against 27.8 last year. These figures show a notable gain in popularity for both the half elliptic, as well as cantilever, over the three-quarter elliptic type. Five listed cars are using the elliptic type this year, the Franklin, Jackson, Metz, Dispatch and

Briscoe, as compared with nine last year. The Packard, which was formerly equipped with this type, has adopted the half elliptic suspension. There are four special types of spring suspension this year, three semi-cantilever and three using the platform.

The accessibility of the control members and the method in which they actuate the various parts of the control system has been increased. The brake rods and linkages of new cars give a greater leverage on the brakes in a number of instances, with a less amount of effort on the part of the driver. Probably the point which has been given most attention in brake design is to bring the hand brake up to the same level of efficiency as the foot brake. The hand brakes on the 1918 cars are almost universally as good as the foot brakes. The hand levers are more rigid and the leverage they exert is more powerful. These brakes can be used in conjunction with the foot brake on long hills and will give good service, while at the same time tending to keep the foot brake from overheating.

Mental comfort is as important in a car as physical comfort, and the 1918 cars will be found to give more mental comfort because they warm up more rapidly, they handle the heavy grade of fuel we now have more efficiently; they have better acceleration, due to the improved carburetion; they are not so inclined to be carbonized, and are more responsive to the touch of the operator.

### A Real One-Man Top

A striking feature in the accessory displays at the Palace Show in New York City was an automobile top which may be raised or lowered with a minimum amount of exertion. It was displayed by the Brewer-Titchener Corp., of Cortland, N. Y., and is called the Pioneer Counterbalanced Top. The principle involved is similar, in a way, to the counterbalancing of a window. It is necessary only to slightly raise the top from its folded position, after which it automatically swings out into place and is ready for attachment to the windshield. This is accomplished by means of coiled springs placed in the body of the car and completely concealed by the upholstery. These springs actuate an oscillating member to which the socket structure is attached and the size of the springs is predetermined accurately according to the weight of the top.

### All States Sharing in Federal Road Aid

All the states of the Union have availed themselves of the opportunity of participating in the benefits of the Federal Aid Road Act, which appropriated \$75,000,000 for the construction of post roads and \$10,000,000 for forest roads, according to the report of the Director of the Office of Public Roads and Rural Engineering, United States Department of Agriculture. That the passage of the act has stimulated road building is shown by the fact that in 1916 there were approximately \$41,000,000 of state funds expended for all highway purposes, and it is estimated that in the calendar year 1917 the aggregate expenditures of state funds for this purpose will be at least \$60,000,000. A number of the states have made specific appropriations to meet Federal aid dollar for dollar. Among these are New York, Illinois, Michigan, Rhode Island, Nevada, Iowa, Florida and Vermont.

## Women Workers in the Shop

There has been much discussion of late as to the advantages and disadvantages of employing women to replace men in the mechanical industries. As the writer has had considerable to do with women in munition factories both here and in Canada, it may be that his experience will be of value to others.

While on general principles one dislikes the thought of employing women on work that has been done entirely by men, industrial conditions seem to warrant such employment at the present time; and as the conditions have been forced on us, we must make the best of them. Disregarding sex and looking at the problem from a purely economic or commercial standpoint, the employment of women in mechanical lines has many advantages. When proper care is exercised in assigning work that is fitted to a woman's strength, when the hours of labor are kept well within reason, and other things are equal, there is no more reason why women should not be employed than in other lines. Actually, a great deal of the work on which they can be employed in machine shops is lighter and less monotonous than many occupations that have fallen to their lot in the past.

The fact that women, as a rule, are not naturally of a mechanical turn of mind is, strange to say, one of the best reasons for employing them on repetition work, and especially for running machines of a more or less delicate and complicated construction that require some adjustment from time to time. This fact is illustrated by the experience of a Canadian fuse factory. When men were employed on a number of semi-automatic machines it was almost impossible to keep the machines in repair. In spite of everything that could be done, the men insisted upon trying to make their own adjustments and minor repairs. Not being mechanics, they were not provided with the proper tools for this work, and so would use anything they could lay their hands on. Fuse bodies and monkey-wrenches were used for hammers and pieces of pipe, old files, etc., were jammed into the mechanism of the machines. Bearings were tightened until they ran hot and scored. Gibs were tightened until they bound and refused to work or were loosened until the slides ran out of true and spoiled work. Sight-feed oil cups were stolen and presumably sold for junk. As soon as the men were replaced with women, the repair of the machines became normal. Besides, production began to increase as the girls acquired the necessary skill, until in a few days their production was much greater than that of the men.

These results were due to two things: the misplaced mechanical initiative on the part of the men operators, and the entire lack of this faculty on the part of the women operators. The men would not give the mechanics or toolmakers a proper chance to keep the machines in repair, while the women, when anything went wrong, instead of trying to fix it themselves, were only too glad of the chance to sit back and take a rest while a competent man did the work.

On other classes of work it was found that, when properly managed and disciplined, the women operators acquired greater skill and speed than men employed on similar work. This was especially true of work of a light nature that required speed and accuracy of handling. This is due, in part, to the fact that women's hands and minds are practically untrained to systematic motion, so

that they more readily lend themselves to instruction, and when once taught the proper rotation of movements required to do a given task in the least time, they stick to these movements and soon become efficient operators. Men, on the other hand, especially if left to themselves long enough to acquire a wrong method, are more inclined to be stubborn and assume that because the way they are doing the work seems easy to them their way is best, without stopping to analyze it.

As this is the case, if women must be employed, they should be paid equal wages for equal work. Their strength must not be unduly taxed, suitable convenience must be provided for them, and the hours of labor restricted. In return, they will give higher production and lower operating costs.—Donald A. Baker, in *Machinery*.

## Malleable Iron and Its Uses

At a meeting of the American Iron and Steel Institute an article on malleable iron and its uses was presented by Henry F. Pope. He said that iron as it is run from the furnace and poured into the molds in the process of making malleable iron castings is not malleable at all, but is extremely hard and brittle. When broken, it shows a white fracture. But this brittle iron is of such composition that when subjected to the proper annealing heat for the requisite length of time, it is transformed into an iron with entirely different physical qualities. After annealing, instead of showing a white fracture, it shows a black one, giving it the name of "black heart." This distinguishes the malleable iron made in this country from that made in Europe, which has a steely fracture, due to the fact that the carbon is almost entirely removed by oxidation in the annealing process. The black fracture of American iron is due to the fact that in the annealing process the carbon, which in the original casting was all combined, has been separated out by decarbonization and is now found as free carbon or graphite of non-crystalline form deposited between the molecules of the iron. This form of carbon is called "temper carbon." The presence of a large amount of temper carbon gives the material its black appearance. The iron itself, therefore, is left almost entirely free from any combination with carbon and possesses the malleable quality of wrought iron. It can be bent without fracture and withstands great shock and stress without breaking. It has the superiority of wrought iron in the respect of malleability without the sometimes objectionable fibrous structure of that material. Someone will say "Why use malleable iron any more when steel castings may be had?" That is a pertinent question, for great strides have been made in steel casting production and certain castings have been changed from malleable iron to steel with improved results; but there are several reasons why steel will never displace malleable iron for a multitude of articles. In the first place, in most cases, if the steel could be produced in the form and section of the malleable casting, it would be more expensive and no better; for, while the tensile strength of malleable iron is somewhat below that of soft steel, its elastic limit is just as high, which means that it will stand just as severe service as the steel. Years ago malleable iron began to be used advantageously for agricultural implements, all sorts of farm tools, wagon and carriages, harnesses, stoves, pipe fittings, and for many other purposes. Later the railroads began to use it, for many parts of cars could be



made lighter and less subject to fracture by the substitution of malleable for gray iron. The railroads also used it in places where the iron is exposed to the corrosive action of the weather, for malleable iron is as non-corrosive as any of the iron products and much more so than steel. More recently malleable iron has become popular in automobile construction. Other good qualities are its high permeability and its low magnetic hysteresis, qualities which render it desirable for certain electrical machinery.

### Correct Allowance for Bending Sheet Metal

It is important to make the correct allowance for bends in sheet metal in the design of fittings. Randolph F. Hall and B. D. Thomas have carried out a number of measurements on bends around a 1 in. square bar and Mr. Hall has embodied the results (lengths measured along the neutral axis) in a chart which he has published in *The Aeroplane of London*.

A number of strips, 18, 16, 14, and 12 gage sheet steel, were bent over a 1 in. square steel bar, with corners rounded in each case with the radius equal to the thick-

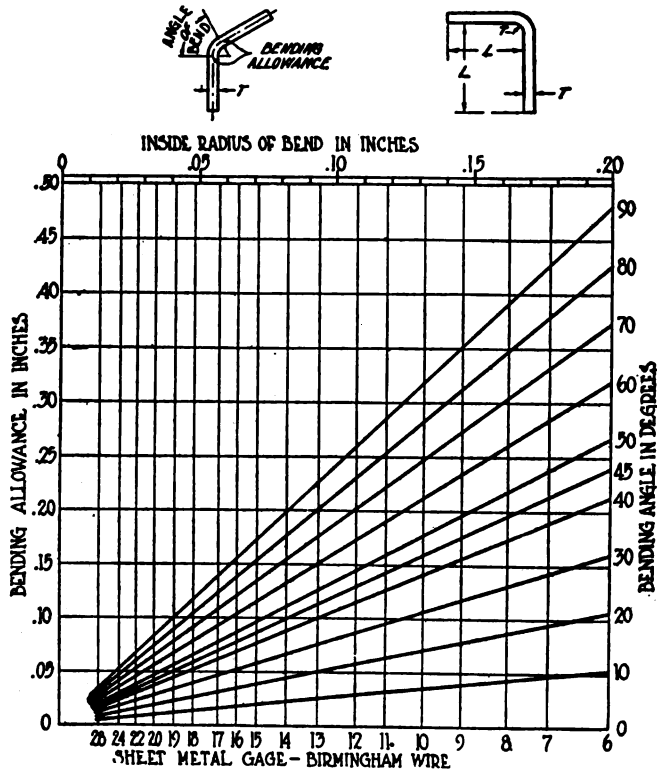

From the point on the horizontal scale denoting the gage of the metal pass up to the inclined line denoting the angle of bend, and then to the left, where the allowance can be read off

ness of the metal. Had no allowance been required for bending, the ends of the strip would have met in the center of a face of the bar, but instead a gap resulted, which divided by four gave actual allowance for one bend. The allowances required per bend were between 33/100 and 38/100 times the thickness of the metal, and the mean of ten different tests confirmed the allowances computed on the neutral axis. From these experiments the curves of Fig. 1 were deduced, allowances for angles less than 90 deg. being made proportionately. Results in the factory verify the chart. If the corners are hammered flat, less allowance is required, but the fitting is weakened.

### Executive Committee Meeting of C. H. A. T.

A meeting of the executive committee of the C. H. A. T. was held at the Business Men's Club, Cincinnati, at noon, Tuesday, December 18, at which a dinner was tendered the members and guests by J. Frank Hutcheson, president of the organization. Those present were as follows: G. W. Huston, Theodore Luth, H. S. Cox, W. J. R. Alexander, C. J. Rennekamp, A. C. Poggendick and J. Frank Hutcheson.

During the meeting the coming convention and arrangements were discussed, the following committees being appointed:

Entertainment Committee—C. J. Rennekamp, G. W. Huston, A. C. Poggendick, W. J. R. Alexander, W. J. O'Brien.

Membership Committee—Jos. Niehaus, H. S. Cox, Otto Heinerichsdorf, C. J. Rennekamp, J. L. Parker, James R. Swan, Carl Kloos.

Publicity Committee—G. W. Huston, W. J. R. Alexander, E. H. Eggers, H. W. Voss, O. A. Timberlake.

It was agreed that the president and secretary of the association should be members of each committee.

Menus for the banquet were submitted by the Sinton and Gibson Hotels, and were turned over to the chairman of the entertainment committee with instructions to make investigation and report back to the executive committee the result of their investigation.

The members present complimented the work so far accomplished by the secretary and heartily approved his idea of going after delinquent members. They endorsed a suggestion that a list of members be published in book form, together with firms with which they are connected.

### Declaration of Automobile Weights

Considerable difficulty has been experienced by Chilean importers of American automobiles by reason of the failure to state the exact weight of the shipment. The inaccuracy is generally due to the fact that an extra wheel or other part has been included without account having been taken of the added weight. In practice the Chilean customs officials allow a variation of only one-half of one per cent in weight, and any excess is subject to fine. It is important therefore, says Special Agent Grosvenor M. Jones, of Concepcion, that great care be exercised in stating weights. It is suggested that errors of this kind could be avoided if the shipping order in the factory carried a note stamped in red ink or otherwise marked to indicate to both the billing and the shipping departments that the case contained extra parts and that the stated weights should be correspondingly increased.

### Death of Wm. E. Maxwell

Wm. E. Maxwell, purchasing agent for the past 25 years of the Parry Mfg. Co., of Indianapolis, Ind., died December 21 after an illness of several weeks. Mr. Maxwell was well known in the vehicle trade. He was a member of the executive committee of the Carriage Builders' National Association and a regular attendant at the conventions of that organization.

Mr. Maxwell was born on a farm in Rush County, February 28, 1860, and moved to Indianapolis with his parents in 1865. He was an enthusiastic Mason, a member of the Scottish Rite and the Shrine. He is survived by the widow, three sisters and one brother.

### Abundance of Vehicle Woods in Memphis District

Two distinct classes of wood are demanded by manufacturers of vehicles: strong and tough woods for wheels, poles, axles, hounds and other parts of the running gear; and moderately light, fine-grained woods for bodies and panels. The strong woods in most demand are hickory, oak and ash; the fine-grained kinds are more numerous, but yellow poplar, red gum, cotton-wood and tupelo are among the most important.

An examination of the forest resources of the Memphis district reveals the fact that these woods are abundant there, and that vehicle makers depend to a larger degree upon that region for material than upon any other single region of the country. Take hickory as an example. The whole sawmill production of this indispensable wood in the United States is placed at 86,000,000 feet per year. Of this amount certain southern states are credited as follows:

	Feet
Arkansas .....	13,443,000
Tennessee .....	11,933,000
Kentucky .....	8,708,000
Missouri .....	5,236,000
Louisiana .....	3,770,000
Mississippi .....	3,220,000
Alabama .....	1,019,000
<hr/>	
Total .....	47,329,000

This leaves less than half of the hickory supply to come from all the rest of the country. That is, the seven states which are tributary to Memphis furnish more of this highly important vehicle wood than is furnished by the remaining 26 states which are credited in government reports with hickory production.

The showing is nearly the same with regard to ash, though the proportion supplied by the states named is not quite so high as in the case of hickory. However, these seven states, with Texas added, yield 74,000,000 feet of ash a year, while the output of this wood in the whole country is 159,000,000 feet.

Relatively few kinds of lumber are suitable for wagon box boards. Several qualities must be taken into consideration, and the grading rules are strict. The wood ought to be reasonably light; it should be of fine grain so that it will dress smooth; it ought to take and hold paint well; it ought to be rather hard in order to resist wear; and, of course, it should not warp badly or split and check during weather changes. The difficulties of finding all of the qualities present in a single wood are responsible for the short list of woods suitable for wagon box boards. The country has been pretty well searched for material that will meet these requirements. Boards are wanted from 13 to 17 in. wide and long enough for a wagon bed.

The Memphis region produces three woods available for such box boards. They are tupelo, cottonwood and red gum. Several others are occasionally employed but the demand for them is not large.

Tupelo, or cotton gum, has taken the place of yellow poplar as a box board wood to some extent. Poplar is less plentiful than formerly and of higher price, and tupelo closely resembles it in appearance. Cottonwood stands on its own merits and is not thought of as a substitute for anything. It is light and tough, has a smooth grain, and paints well. The fertile lands along the lower Mississippi

and its tributaries produce the finest cottonwood for box boards. Willow growing in the same situations is nearly as good and it is received without prejudice in many vehicle factories. Red gum has come into extensive use as wagon bed material in recent years. Formerly it was objected to because the processes of successful seasoning were not understood; but that has now been remedied and red gum box boards rank as high as yellow poplar and white pine ever ranked in the days when those timbers were abundant in the highest grades. The large sizes of red gum trunks make it easy to procure the broad boards demanded for beds of farm wagons.—Hardware Record.

### Industrial Education for Crippled Soldiers

Canada is understood to have about half a million men in the field. She has been at war three years. The number of men returned who have undergone amputation is less than 900; the total number of blinded is 32. Ninety per cent of all returned wounded go back to their old jobs, leaving 10 per cent to be re-educated. In France 99 per cent of the wounded return to their previous occupations. We may expect the same percentage in Canada where until now, however, "only the more seriously disabled" have been returned.

The province of Ontario has sent over 200,000 men, or half of the entire Canadian contingent, into the field. Up to October about 9,000, or two per cent, had returned incapacitated for service by wounds of the severer sort. Of these only 101 had lost one arm. Only one lost both hands. Only four were blinded. 72 lost one eye. 13 lost one hand. 12 lost one foot. Six lost both legs. Only three are "totally disabled."

In one factory famous for its efficiency and high wages in the United States are 1,585 defective men whose listed defects are singularly like those in the Ontario list except for the cases just noted. Its force is never thought of as deficient in any respect, but the reverse. Its employes number one-fifth of the Ontario soldiery and its defective men are one-sixth as many.

Undoubtedly many more men are injured annually in American industries than we may expect in a year's war. 70 per cent of all injured men never had a trade. Consequently the teaching of any trade or any kind of machine operations to this 70 per cent gives them better incomes and easier work than their former occupations.

The question is an individual one, and every case is investigated separately, in the light of the medical, technical, economic and personal factors of his case.

To take typical examples. A bricklayer and mason was shot through the shoulder. He cannot raise his right hand above his shoulder, cannot plaster over head or high up. He has an eighth grade schooling. He is apt. He becomes an exceptionally good draftsman.

A machine shop fitter used to handling heavy pieces was struck across the abdomen. The muscles are so weakened that he cannot lift much. He is quickly taught enough of the machinist trade to give him good work and wages.

A man with one leg is taught a sedentary job.

A man without a trade and not especially apt is taught to operate one or two rather simple machines at better wages than he formerly enjoyed.

Thus reeducation to the extent of from 97 to 99 per cent is nothing else than common, ordinary industrial education—simply a matter of "sawing wood" in established industrial schools, in day, continuation, and night classes,

and in factories when the crippled man is so nearly competent to do the proposed work that the employer can properly put him to work, supervised by some one in the establishment.

The practical, everyday doing of this work in Canada is directed jointly by two bodies, one the Military Hospitals Commission which has military direction of injured men until they are ready to re-enter civil life, and the other the Provincial authorities for Industrial Education.

### The "Taylor" System

Away back in the eighties Frederick Winslow Taylor, the originator of what is known as the Taylor system of shop management, began the series of investigations which made him famous. He saw that there was not only great unevenness in the quality of management of great businesses, but also in the quantity and quality of work done by different grades of workmen. Though first class workmen could do four times as much work as the average man, both received the same rate of pay. This system discouraged efforts to excel. He aimed to alter it. He adopted for his motto, "High wages and low labor cost." To get these he analyzed the motions of workmen, taught them to cut out those that were useless and to economize effort. He provided the best machines and tools and insisted that they should be used to the limit of their capacity and speed, and to secure his ends made it a rule never to employ any man who on piece work could not earn at least 60 per cent more than the average rate paid to the ordinary workman.

Taylor's method was to divide each man's work into its elements and find out the time required for each element, and base his estimate of what a man can do upon the record so made. For example: Men loading pig iron into railway trucks were timed. The elements were (1) picking up a pig, (2) walking on level ground to the truck, (3) walking up a plank, (4) putting down a pig, (5) returning to the pile. The average work done per man was to load 12 tons per day. From his analysis he concluded that 45 tons could be done. He fixed a piece rate which would secure a 60 per cent increase in wages to men loading, by his methods, 45 tons per day. It was accepted. He would not keep a man who could not perform the task. The work became popular. The high wages attracted first class men, and the system was gradually extended to all other classes of work. Taylor never had a strike.

Another innovation introduced by Taylor was the employment of what he calls "functional foremen." The duties of foremen under the old system were so many and varied that men with the necessary qualifications to perform them were rare. Taylor had accumulated a vast amount of classified knowledge of workshop practice, capacities of machines, methods of working them, and properties of tools that were useless, if workmen were permitted to choose their own methods. He did away with the ordinary foremen who controlled small groups of men, and put in their places functional foremen, of whom there were eight kinds. Four were on the office staff, namely: (1) Order of work and route clerk, (2) instruction card clerk, (3) time and cost clerk, and (4) shop disciplinarian; and in the shop he employed (a) gang bosses who prepare work up to the time it goes into a machine, (b) speed bosses who see that proper tools are used and right methods employed, (c) inspectors who are

responsible for quality of work, and (d) repair bosses who see that machines are kept in order.

Workmen under Taylor's system keep the records of their own work and time. Their cards go to the proper clerks in succession. The last to get them is the pay clerk, so that wages cannot be paid until all information required by other clerks is supplied; therefore little trouble arises from the time cards.

Machines have multiplied the power of human hands and increased production. Taylor's methods have added to the capacity of machines by increasing the efficiency of labor, creating new openings for brain workers, and raising the intellectual and living standards and earning power of workmen.

### Lang Body Company's New Plant

The Lang Body Co., recently incorporated under the laws of Ohio for the purpose of manufacturing automotive bodies, will be the first ideal body production plant in Ohio, being located on five acres of land on West 106th street, in the immediate vicinity of one of Cleveland's manufacturing centers and also in the heart of the automotive industry of the country.

The first unit, a three-story ell-shaped building of 50,000 sq. ft., and a dry kiln are finished. The machinery is being installed and the plant will be in operation by February 1. For the present the company will devote most of its time to the manufacture of commercial bodies but later will specialize also in the closed car work, in which the personnel of the concern has had an enviable reputation in the past.

The company is headed by E. J. Lang, one of the founders of The Rauch & Lang Carriage Co. and later vice-president of The Baker R. & L. Co. He has had 38 years' experience in the body building field and will be assisted



by L. L. Williams, the company's engineer, who was formerly of the body department of the Peerless Motor Car Co.

The vice-president and general manager of the company, Elmer J. Lang, who has also been identified with The Rauch & Lang Carriage Co. and The Baker R. & L. Co. in the capacity of sales manager, will devote his entire time to the general management and sales end of the company's business.

The following members constitute the efficient board of directors back of this company: John H. Price, Price, Alburn, Crum & Alburn, attorneys; Thomas E. Monks, president The Cleveland National Bank; J. P. Loomis, president The Akron Coal Co.; S. W. Whitmore, president The Whitmore Mfg. Co.; E. W. Livensparger, state agent The Baker R. & L. Co.; C. W. Brainerd, vice-president The National Screw & Tack Co.; E. I. Heinsohn, president The Cleveland Welding Co., and the Langs.

## Paint and Varnish

### The Opportunity of the Small Shop Painter

The small shop painter, or, if you please, the small village or town painter, has reason to smile and look pleasant. He has in a sense come into his own; business is everywhere for the asking. The good roads, fine as the city streets, and the car to get after business 20 miles away, are realities which even the country painter may enjoy. The limits of trade are not bounded in terms of 10 or 15 miles at all points of the compass from the shop. Whole counties offer tribute to the painter if he elects to canvass for the business. Fifty miles means no more to the car driver today than a journey of 20 miles with the plodding horse meant scarcely more than 15 years ago. The distant neighbor of a few years ago becomes by virtue of the automobile a very near neighbor. All of which shows that the painter is responsible if he fails to take advantage of the opportunity which present day conditions and circumstances have brought to his door.

Right at this time when business as a rule is a little slow with practically all car painters, the small shop painter, if provided with reasonably commodious quarters, may go out and pick up a good volume of work, or by suitable advertising, have the work come to him. It is just a case of meeting the car owner and showing him, either through the local papers or by personal interview, that his interests and your own are mutual, and that you both profit by a transaction in which an even interchange of values is enjoyed by all parties concerned. It is to his advantage to have his car kept well protected under a secure fabric of paint and varnish, and it is to your advantage to furnish him with the service which will insure such protection.

This being the true state of affairs why delay, at a time when delays can ill be afforded by the painter, to bring the importance of the matter directly before the car owner? Personal canvassing, so far as possible, is one of the most effective forms of advertising and getting business. Next to this comes the local newspaper advertising; this should be kept before the readers through a series of weeks, each week to witness a change in the wording of the reading matter. The car at this time will need at least a coat of varnish for the winter work and for the protection of the undercoats. Also the new coat of varnish, or any re-painting performed during the early winter, comes at a time when the best possible attention may be given the work.

### Color Comment

The blue pigments are passed along as being difficult to place upon the surface and obtain anywhere near perfect color effects. Varnish is known to be highly injurious to the blue pigments, and especially the deep blues, and for this reason it is important that the color should be used in as many coats of varnish as may be convenient. For a fine ultramarine blue the ground color may be lampblack, or dark brown, or a blue made up of Prussian blue and Artic or silver white. For a medium shade of ultramarine, lampblack gives a splendid ground. Then mix

about three ounces of blue in a pound of rubbing varnish and apply freely to the surface. To insure a perfectly covered field two coats of the blue, both mixed as here detailed, had best be applied. The following rubbing coats of varnish should be made to carry at least a fraction of pigment to at least a pint of varnish in order to prevent discoloration of the field color by the varnish.

Of course, where it is necessary to stripe the surface the color must be omitted from the last coat of rubbing varnish. In this case the color will be submerged under two coats of varnish, and to save the color as much as possible it will be desirable to use the palest varnish, both rubbing and finishing, that may be obtained. However, in the greatest number of cases that may be arranged for, the color should be used in the rubbing varnish coats right up to the last. In this manner the very finest effects are to be had. Light blues are to be preferred to the dark ones, as they are invariably least affected injuriously by the varnish.

For a strictly high class job of painting blue it were the best practice to apply a coat of the blue thinned with turpentine only directly over the lampblack, or other color base. Then flow on the blue varnish-color. It will be observed that the varnish-color will at once saturate the flat color—pick it up, as the saying goes—so that the surface takes on the precise appearance of the moist color as seen in the container. The processes from this one on may be in the order as explained above.

The greens have never been considered difficult colors to place to advantage upon the surface. Nevertheless, even these colors may be made to respond wonderfully to a little extra work applied. It is certain that the more refinement one works out upon the surface preparatory to the application of the green pigment the finer the effects secured; also the better preparation of the color the greater lustre and the greater depth of tone in addition to handsomer general results.

### Maroon for the Automobile

Maroon for the automobile represents a color in no wise second to numerous other beautiful pigments. Among the maroons none are more attractive, all things considered, than automobile maroon, a color put out by advertisers of The Hub. Automobile maroon is a color of dark, deep, magnificent brilliancy which under a proper finish glows with a touch of royalty. Practically all maroons are good wearing colors, and withal very durable if kept well protected under a substantial flow of varnish, as they should be. Maroon is far from being a sensational color, although it is conspicuous and fine enough to attract immediate attention anywhere.

A strong, virile under surface should be provided for maroon. It does not conceal surface defects, nor does it unduly display them, which makes it necessary to provide a practically perfect foundation for the color. The important thing is to build up a surface that, when the ground color is placed, will need no patching up. The ground color for automobile maroon—for any maroon, as a matter of

fact—should be very near the real maroon both in shade and tone and fineness of surface film. Indian red saddened a bit by the addition of ivory black makes a proper ground color. After this coat has dried out right and good on the surface, break up some of the maroon in turpentine and liquify thoroughly, adding to the pint of color as smoothed out with the turpentine, a teaspoonful of raw linseed oil. Apply to the surface with a camel's hair brush. Permit this coat to dry over night. Then break up some of the maroon in turpentine to a heavy cream consistency. To three-fourths ounce of maroon, after breaking up with turpentine, add a full pint of elastic rubbing varnish, and flow freely over the surface quite as clear varnish would be flowed. In due time deaden the gloss lightly with a fleece wool sponge moistened and dipped in pumice stone flour, making the rubbing light and uniform.

The second coat should carry, say, one-half ounce of maroon to a pint of varnish. On the second coat, after rubbing with a roll of felt or a block of this material, and water and pumice stone flour, apply whatever striping and ornamental work is desirable. Then wash very clean, as if for the finishing coat; then flow on a coat of pale clear rubbing varnish. This coat will need just enough rubbing to lay down all surface coarseness and smother the gloss. Then wash up most carefully, and finish with a very pale durable body finishing varnish. Gold and black lines appear to advantage upon all maroons.

### Creating a Finish Upon the Old Paint Foundation

Naturally the car owner desires the old paint base to hold up as long as possible. A new surface built from the metal or wood base costs at this time of soaring prices an amount worth even the millionaire's attention. If the old foundation is in good shape with the checks only running to a shallow depth, it can be surfaced down with blocks of pumice stone and water, or sandpapered, as the conditions seem to warrant, and make fit in every way to take on a new finish and hold it securely.

The surface will need as a first step in the work a thorough washing and cleaning up. Then rub or sandpaper down, as choice maybe made, after which all defects will have to be touched up with a first coat pigment mixed with a sufficient amount of raw linseed oil to bind it fast and strong. The pigment may best be some good lead or oxide material suited to metal or wood; this with the reinforcement of oil forms a fine first coat pigment. When this touch-up pigment has dried properly the defects should be puttied with the hard drying carriage putty.

After 24 hours this will do to surface down with No. ½ sandpaper. If the patches are too large they had best be rubbed down with the block pumice stone and water. Next mix a thin coat of keg white lead and lampblack in one part raw linseed oil and three parts turpentine. Apply freely with a camel's hair brush. The fine checks will take up a considerable part of the elements of this coat. Above this, in due time, apply a couple of coats of roughstuff. If the surface is in a shape to warrant it, an extra coat may be put on. Stand aside for a week; then rub with blocks of artificial pumice stone and water, working the surface down to a level and fine condition. The checks will have disappeared, and next in order comes a coat of color, to be followed next, in due course, with a coat of varnish-color, this latter to be flowed on richly.

Rub this coat lightly and follow with a second coat of

rubbing varnish carrying a little of the color. Rub when the coat is hard, and apply a coat of clear rubbing varnish; this in time will take a solid rubbing; then clean up and finish with a heavy, hard drying finishing varnish. This fetches the finish along in good shape, at a moderate cost, and helps to postpone the day when the old surface of paint and varnish must come off entire. Moreover, such an amount of wear and good service may be had from the old finish being used as a base for the new that all concerned may be satisfied and made to feel that there has been a profit all around.

### Touching Up for the Varnish

The touch-up-and-varnish job furnishes the careful man a chance to exercise his ingenuity. First the cleaning of the surface for the varnish. This will need to be very thoroughly performed. Then a light rubbing will at least be in order. This will serve to clear off any grease smears and foreign accumulations of all sorts. Then in touching up with the color great care will be needed; it is most difficult, to begin with, to exactly match the old color, so that the least touching up consistent with the absolute requirements of the surface will be found the wise practice. Touch only those places urgently in need of freshening up. Confine the color precisely to the size of the spot. Use for the touching up work a lettering pencil. This will insure the application of the pigment to the part needing it, and not necessarily to any other part.

Around moldings, panels, corners, etc., it is often difficult to dislodge the dirt and fine dust. To secure such places against doing damage to the varnish brushes, run a thin glaze of dark shellac in them, using for the work a striping pencil. In all touch-up-and-varnish jobs it is best to fasten down all particles of dirt which cannot readily be removed by the usual processes of cleaning. This is the only feasible method of getting clean and satisfactory work.

### Paint and Varnish in the United States

Business men who deal in paint and varnish, and those who make use of those materials in substantial quantities are provided with much practical information regarding their composition and most effective uses in Circular No. 69 of the United States Bureau of Standards. The value of such a publication is measured by the magnitude of the paint and varnish industry in this country, where it is probably more highly developed than in any other part of the world. "While it may not be proper to class it as one of the great American industries," states the Bureau of Standards, "it is of practical importance to all householders, and its financial importance is much greater than is generally known." The value of the annual output of these products in the United States is about \$125,000,000.

The book contains chapters on the general nature of paint and varnish, methods of manufacturing varnish, detailed descriptions of the various paint pigments, the preparation of paints, application of paint and varnish, and specifications for painting. There is also a glossary. Copies of Circular No. 69, "Paint and Varnish," may be obtained at 15 cents each from the Superintendent of Documents, Government Printing Office, Washington, D. C.

If your business does not increase, the first place to look for a reason is usually in the advertising department.



**Why Cars Cost More**

Everything in connection with the manufacture of a car has gone up, and naturally retail prices have gone up correspondingly. The materials which enter its construction have advanced on a far more rapid scale than the finished cars themselves have. A few examples of this may be mentioned:

Frame steel, which cost \$1.35 per cwt. in 1916, now costs \$5.25, an advance of 289 per cent.

Sheet steel, which cost \$2.75 per cwt. a year ago, now sells for \$8.15, an advance of 297 per cent.

Aluminum castings, which were bought by manufacturers at 28 cents a pound a year ago, now cost 50 cents a pound, an advance of 79 per cent.

Cast iron, for cylinders and other engine parts, used to be bought, in 1917, for \$13.25 a ton. They now cost \$43 a ton.

In addition to these, leather has gone up 40 per cent, other upholstery items 100 per cent, wheels have gone up 80 per cent, front and rear axles 30 per cent, rubber 75 per cent, cotton fabric for tires 150 per cent, and copper 100 per cent. There is not a nut, bolt or screw of the entire car that has not increased.

Material price increases are not the only factors in the increased price of cars. It costs more to sell a car now than it did a year ago. The rent for the show room is higher, the equipment of the store in which the cars are sold costs more. It costs more to mail letters to prospective customers, more to travel around the country lining up dealers.

In the factory in which the car is made the increased cost of manufacture is due in part to the high prices that the scarce labor is securing. Mechanics and machinists generally are getting more money than they did. It costs more for coal and power to keep the machinery going.

The steel working tools are more expensive by far than they were a year ago. In fact it is almost impossible to get certain kinds of tools for commercial work, as the government seizes these just as fast as they are completed.

One concern that has had an order in for some months to get 25 automatic machines, has had these machines taken by the government just as fast as they have been completed. To date 20 of the machines have been finished and all are in government use. The other five will probably go along with the rest.

With machine tools at premium such as a condition like this is sure to cause, there is scant wonder that automobile prices are going up.

**Vast Extension of Parcel Post Routes Planned**

Within, perhaps, the next three months motor truck parcel post routes will be in operation in various parts of the country aggregating between 3,000 and 4,000 miles. One chain of motor routes will extend from Portland, Me., to New Orleans. Another will cover much of a large stretch of territory in Ohio, Indiana, Illinois and West Virginia. On the Pacific coast routes will be established between San Francisco and Sacramento, Cal., via Stockton and Fruitdale, a distance of 125 miles, and between Redlands and Los Angeles, Cal., via Ontario and Pomona, Cal., a distance of 76 miles.

It is the belief of the Post Office Department that the operation of these routes and others to be established

will materially aid in the distribution and in lowering the cost of food products.

The existing law does not provide for the employment of government-owned motor trucks on rural delivery routes, nor does it require the rural carriers to use motor vehicles.

In the star-route service, however, where the mail is carried under contract, a recent law permits the Post Office Department to designate the sort of vehicles to be employed, and in awarding new contracts the department will specify that motor trucks shall be employed on all routes where the roads are such as to admit of their use. These contracts are advertised for bidders, and where payment asked for the service is deemed to be excessive the department is authorized to provide government-owned motor trucks and to employ drivers for the operation of these routes.

A further extension of the employment of government-owned motor vehicles by its adoption for the parcel-post service of the rural routes will be made whenever Congress enacts a law now pending for that purpose.

**Over 400,000 Cars in Empire State**

The state of New York can boast today of over 400,000 cars, over 131,000 chauffeurs, and receipts to the Automobile Bureau of over \$4,250,000. Figures such as these speak for themselves and tell a story of development befitting the Empire State. Here are statistics showing the increase in motor vehicles and receipts during the past year:

	New York District		
	1916	1917	Increase
Owners .....	137,280	175,105	37,825
Dealers .....	859	1,039	180
Chauffeurs .....	70,818	92,131	21,313
Receipts .....	\$1,255,890	\$2,239,771	\$983,881
	Albany District		
Owners .....	79,261	105,976	26,715
Dealers .....	851	857	6
Chauffeurs .....	17,164	20,512	3,348
Receipts .....	\$602,516	\$942,289	\$339,773
	Buffalo District		
Owners .....	96,007	125,941	29,934
Dealers .....	782	831	49
Chauffeurs .....	15,792	19,149	3,353
Receipts .....	\$716,705	\$1,084,888	\$368,183
	Total for State		
Owners .....	312,548	407,022	94,474
Dealers .....	2,492	2,727	235
Chauffeurs .....	103,774	131,788	28,014
Receipts .....	\$2,575,111	\$4,266,949	\$1,691,838

**New Upholstery Material**

Wilson & Co., Chicago, one of the largest packers and provisioners in the country, has been granted a patent on a new process of preparing curled hair for use in upholstery. The patent is No. 1,248,066. The new process is one by which curled hair is woven on burlap fabric. With the new product a piece of woven hair cut to dimensions, and of uniform thickness, is used in place of loose curled hair which heretofore has been used extensively. The new product eliminates difficulties with properly upholstering seat cushions and makes impossible any bunching of the hair after the cushion is completed.

## The Liberty Motor

When the Congress declared that a state of war existed between the United States and Germany, there was immediate general recognition of the importance of the airplane, and steps were taken to build a large number for the army and navy. The Liberty motor was the outcome of the effort to secure a composite design in which the best ideas of the motor builders of the United States were incorporated. Its advent was announced with a flourish of trumpets, but no details of the mechanical design were furnished for publication. Now we are informed that the Liberty motor is not quite as near perfection as at first believed, but is considered suitable only for scout duty and other comparatively minor air work. Thousands of dollars have been expended in the effort to build the Liberty motor with the utmost possible speed, and the discovery that it is not the equal of the best European motors comes as a disagreeable shock to the American people.

This unhappy development is one of the logical outcomes of secrecy and censorship. Had the design of the Liberty motor been published in the technical journals the government officials would have had the benefit of the constructive and destructive criticism of hundreds of engineers throughout the country. The effect of these criticisms that would have been leveled at the design could not have been anything else but beneficial. One important factor would doubtless have been better taken care of than it is, and that is the design of the motor as regards manufacture. It has been found by tool engineers having to solve the problem of tooling for rapid and efficient manufacture that in many cases the design could be modified with no resulting injury but with great improvement in the speed and ease of machining.

Secrecy is a firmly established war policy, but, so far as we can judge, it serves chiefly one purpose, and that is to keep the common people of the country in ignorance of conditions. The German military authorities doubtless know practically everything of military importance transpiring in this country. Their agents and spies are not dependent upon the daily and technical press as sources of information.—Machinery.

## Offers Government Kerosene Carbureter

An announcement of great economic import at the present crisis was made by the Interior Department at Washington in the form of a statement that the government had been offered the use of a new kerosene carbureter for the period of the war without charge.

The importance of the announcement, however, lies in the fact that the carbureter is evidently a successful one, which means that any doubt as to the sufficiency of the supply of engine fuels for war or domestic purposes is removed. There have been numerous announcements of kerosene carbureters. If successful their widespread use would be assured from the fact that an economy of from 50 to 75 per cent would be effected in fuel costs. This latest announcement from the government seems to indicate that an efficient device has been invented for utilizing kerosene in internal combustion engines with the same facility as gasoline. No less authority than Van H. Manning, director of the Bureau of Mines, is said to be satisfied after investigation and trials of the device, that it will accomplish consistently everything that is claimed for it.

The inventor has applied for patents on his device and will turn the patent rights over to the government until after the war, but it is not known as yet whether the public generally will be allowed the benefits of the carbureter until production for the government is completed and an ample supply obtained.

There are a number of kerosene carbureters on the market and more are being successfully used on tractors and other motor-driven machines of the heavier type, but most of these devices have an auxiliary chamber device for starting the engine on gasoline.

## Lay Brothers to Repay \$25,000

The case against the Lay brothers, of Kalamazoo, George and Frank, in connection with the failure of the Michigan Buggy Co., of Kalamazoo, ended at Battle Creek, Mich., December 15, when pleas of guilty were entered in answer to the three charges—two of embezzlement and one of larceny.

Upon their plea of guilty to the larceny charge, Judge North fined each \$250.

On the embezzlement charges sentence was suspended one year on condition that the brothers pay back to Kalamazoo county \$9,000 to meet the expense of the grand jury, and \$25,000 more to the preferred stockholders of the Michigan Buggy Co.

The case is one of the important ones arising from the sensational failure of that corporation. It has been tried twice before and was brought to Battle Creek by a change of venue, which was granted on motion made by the defendants, who said that they could not get a fair trial in Kalamazoo. The first time the case was tried the court rendered a verdict in favor of the prosecution, but the decision was reversed on error by the supreme court. The second trial was held last May and the jury disagreed.

## Peerless Truck and Motor Report

The ten months report of the Peerless Truck & Motor Corp., Cleveland, for the period ended October 31, shows net profits of \$1,992,413, equal to approximately \$10 a share. This is at the annual rate of about \$12 a share. The company's consolidated balance sheet discloses an excellent current asset position. Of the total current assets of \$8,583,520, cash in the bank is represented by \$2,450,904. Current liabilities are \$1,557,262, leaving a net working capital of \$7,026,258. This does not include the \$2,500,000 received in payment for the company's Long Island plant, sold recently to the government. This sum added to the working capital provides the company with excess current assets of \$9,526,258. Such an amount would permit the company to pay off its \$5,000,000 of notes and there would still remain \$4,526,258, equal to \$22.60 a share. The stock is now selling around \$11 a share. Gross sales for the period were \$17,013,113 as compared to sales \$16,621,038 for the entire 12 months of 1916. A surplus of \$5,415,334 was reported.

## Foreign Trade Convention to Center on War

James A. Farrel, chairman of the National Foreign Trade Council, has issued the formal call for the Fifth National Foreign Trade Convention to meet at the Gibson Hotel, Cincinnati, O., Thursday, Friday and Saturday, February 7, 8 and 9, 1918. The theme of the convention will be "The Part of Foreign Trade in Winning the War."

## Gasoline Now Plentiful

Instead of curtailing the use of motor vehicles as has been necessary in England and France to conserve gasoline for military uses, American car and truck owners will be doing their country a service by using their machines to the fullest extent for the relief of passenger, freight and express traffic on the railroads in the United States, according to the Petroleum War Service Committee of the Council of National Defense.

The gasoline situation, which threatened last summer to result in a shortage, has changed radically. Gasoline economy, due to the campaigns recently encouraged by the U. S. Bureau of Mines, the drilling of new oil wells, increased production of gasoline by the "cracking process," decreased use of automobiles during severe winter weather and lack of shipping facilities for export to Europe have combined to cause consumption to fall below production. The reserve supply accumulating will tax storage facilities to the utmost before the winter is over.

A statement issued by the Petroleum War Service Committee indicates that it is desirable to use gasoline for power purposes to insure continuous and ample production of fuel oil for the navy. Gasoline is in the nature of a by-product of fuel oil, which is used also in merchant ships, munition factories and other industrial plants.

As gasoline cannot be stored in large quantities because of lack of storage facilities and inability to build additional storage tanks at this time, and as it is impossible to ship more gasoline abroad than is now being forwarded to Europe, it is evident that in the present coal shortage and railroad congestion, every effort should be made to utilize motor trucks and passenger automobiles for hauling merchandise and carrying passengers on utilitarian errands.

The gasoline situation in this country is not to be compared with that in Europe. England and France are almost entirely dependent upon imports of petroleum products and the ability to import is limited by lack of ships. It is for this reason that the use of motor cars for private use has had to be suspended except for the most urgent requirements. America, on the contrary, is the world's largest oil-producing country and is unable to export more than one-quarter of its gasoline production. To the extent that gasoline, kerosene and fuel are used for power purposes the supply of coal is conserved.

## Wagon Department Meets

Approximately 50 concerns representing over 90 per cent of the farm wagon industry attended a meeting of the Farm Wagon Department of the National Implement and Vehicle Association, at the La Salle Hotel, Chicago, December 18. Representatives of other vehicle making manufacturers also attended. The meeting was called partially to consider existing conditions as regards domestic trades and also the further allotment of government orders for vehicles used in transporting war material.

E. E. Parsonage, of the John Deere Wagon Co., of Moline, Ill., was elected president, and F. F. Alexander, of the Electrical Wheel Co., Quincy, Ill., was elected secretary and treasurer; A. B. Thielens, of the Studebaker Corp., South Bend, Ind., and B. P. Thornhill, of Thornhill Wagon Co., Lynchburg, Va., were elected as members of the executive committee.

It was reported that many concerns are now making nothing but standard wagons.

In reporting upon domestic trade conditions it was shown that various concerns had been compelled to either discontinue entirely the taking of orders for wagons for domestic use or taking them subject to factory conditions in executing them. In some instances orders are taken only in blank as to prices and terms, making it a condition of such orders that the price shall be based on cost of production and a fair profit at time of shipment.

The matter of terms was taken up and it is quite evident that the very exigencies of the existing situation will bring about a marked shortening of various terms.

## New York Exports \$9,481,394 in November

Exports of passenger cars, trucks and parts from the port of New York for November totaled \$9,481,394. This includes shipments of 1,403 passenger cars, valued at \$3,844,194, and 1,403 commercial vehicles and motor trucks valued at \$3,446,072. The value of parts exported was \$1,921,595.

Russia was the largest purchaser of passenger cars, 202 cars valued at \$454,781 being shipped there from New York. Australia's purchases rank second and amount to 551 cars valued at \$437,310. The average value of the car sent to Russia is three times as great as that sent to Australia. England leads in the number and value of trucks exported, having purchased 971 commercial vehicles and motor trucks valued at \$2,316,478. France ordered 106 trucks at \$297,146.

Our shipments to the Allies were by far the largest factor in export trade from the port of New York. These amounted to \$4,598,819. The next largest customer was South America, whose bill was \$1,286,310.

## Award Contracts for 4,100 War Trucks

Contracts for 4,100 war trucks, to be delivered early in 1918, for service in the Aircraft Division of the Signal Corps, have been awarded. These include 2,200 of the 1½-ton light trucks mounted on pneumatic tires and specially intended for high speed work, and 1,900 of the 5½-ton trucks of similar design but mounted on solid tires. The contracts have been awarded as follows:

### 1½-Ton Light Trucks

Signal Motor Truck Co.....	500
Republic Motor Truck Co.....	500
Denby Motor Truck Co.....	500
General Motors Truck Co.....	700

### 3½-Ton Heavy Trucks

Standard Motor Truck Co.....	250
United Motor Truck Co. (Grand Rapids).....	250
Federal Motor Truck Co.....	500
Kelly-Springfield Truck Co.....	500
Velie Motor Co.....	400

## Chewing-Tobacco Clears Windshield

While inventors are trying to devise something that will effectually prevent the fogging of automobile windshields in rainy weather, along comes Theodore Petersen, a druggist in Grand Rapids, Mich., with a plug of ordinary chewing tobacco and solves the whole problem!

Not only does the tobacco prevent the windshield from fogging, he says, but it enables the rain water to run off the glass without collecting in drops. After each application it is only necessary to rub off the glass with a cloth to remove all marks of the tobacco.

### England Developing Use of Coal Gas

The development of the use of coal gas as a fuel goes on steadily in Great Britain, and is likely to so long as the present gasoline shortage lasts. Recently a show of representative vehicles running on coal gas, held in London, included some 45 entries. Among these were two examples of cars running on coal gas stored in steel cylinders at high compression. This seems to be the next phase in the adaptation of coal gas for the road, but the use of steel for this purpose has its drawbacks. At the high pressures used, not only must the storage cylinder be kept under very careful inspection, but it has to be frequently annealed.

Considering this, and the desirability of economizing steel, and work in steel, one firm has already produced a gas cylinder containing no metal. It is made of fabric and rubber, encircled at intervals with rubber rings, and one of these containers, 5 ft. long and 12 in. internal diameter, has stood a hydraulic pressure of 1,600 lbs. per sq. in. Normally, however, it is charged to 1,000 lbs. pressure, when it will hold 600 cu. ft. of gas. The whole thing weighs less than 100 lbs.

Another container is on somewhat similar lines, but the gas is introduced through a central tube which acts as a tension stay for the ends, and the walls are retained by steel rings.

### Auto Industry Helping Win the War

The American automobile industry in the coming 12 months will turn out \$1,000,000,000 of war products, comprising trucks, shells, airplane parts, motors, recoil mechanisms, artillery carriages, steel helmets, mine anchors and other products used directly in prosecution of modern war. Born only 20 years ago, the growth of this industry, especially in the past five years, has been so phenomenal that today in the marshaling of America's resources in the world conflict the motor companies constitute, second only to the steel industry (in the expansion of which they have played an important part), the best equipped industry in the country to furnish war materials.—Wall Street Journal.

### 1,000 Truck Drivers Needed for France

More than 1,000 motor truck drivers, mechanics and helpers are needed immediately by the American Red Cross for service in France. The duties of these men will be to operate and repair the Red Cross motor trucks which transport supplies to war hospitals. Men in this service will receive pay and expenses.

A recruiting office has been opened at the headquarters of the Atlantic Division, 44 E. 23d street, New York City, under J. Lee Skelly, of the Red Cross Foreign Transportation Department Recruiting Service. Applicants must be over 31 years of age.

### Allies Have 172,125 Motors

According to an investigation conducted by the Japanese government the Entente Allies have 172,125 motor vehicles in use by the armies. Of these 30,000 are owned by England, 80,000 by France, 40,000 by Russia, 10,000 by Italy, 10,300 by Belgium, 1,700 by Roumania, and 125 by Serbia. The Central Powers have approximately 131,050 machines, of which 100,000 are owned by Germany, 30,000 by Austria-Hungary, 750 by Turkey, and 300 by Bulgaria.

### Alabama Adds 99 Miles of State Road

Ninety-nine miles of improved highway were built by state aid in Alabama during the last fiscal year of the State Highway Department. This represents an expenditure of \$276,158.53 by the state and counties. In addition to this, the counties constructed 1,450.5 miles of roads and did much bridge work at a total cost of \$3,447,131.18. When the fiscal year ended this state had 9,536.8 miles of improved roads, compared with 3,780 when the Highway Department was created in 1911.

### Tax Cars by Weight

Idaho is the first state to make the automobile contribute to road maintenance on the basis of weight. Under provisions of a law passed at the last session of the Idaho Legislature and approved by the Governor, licenses will be issued according to the following standards: 2,000 pounds or less, \$15; between 2,000 and 3,000 pounds, \$20; between 3,000 and 4,000 pounds, \$30; and above 4,000 pounds, \$40.

### Premier to Employ Women Machinists

The Premier Motor Corp., Indianapolis, Ind., plans for the employment of between 300 and 400 women. They will be used in the machine tool department to a great extent and will do work that heretofore has always been done by men only. Each will be given careful training in classes of about a dozen before being put at their machines, doing entirely standardized work. They will also be used in the inspection department.

### Goodyear Does \$111,000,000 Business in 1917

The report of President F. A. Seiberling at the annual assembly of officers and directors of the Goodyear Tire & Rubber Co., held in Akron, December 4, showed that the total business of the Goodyear company for the last 12 months amounted to more than \$111,000,000. This business exceeded by just \$11,549,522.05 the mark of \$100,000,000 which was set a year ago as the company's goal for 1917.

### Armleder to Sell on the Coast

O. Armleder Co., Cincinnati, O., has selected Arthur H. Hertz as its coast sales manager, and he is planning to open headquarters in San Francisco. Hertz says that he has been trying to get the Armleder truck in that territory for five years, but the company was too busy filling middle western and eastern orders. He is now busily engaged in finding dealers for it in the coast territory.

### Newark Regulates Welding

Welding of automobile parts, as part of repair shop practice, has assumed such proportions in Newark, N. J., as to have received official notice from the city authorities. That part of the shop work must now be done in a separate room or building surrounded by safeguards against the danger of fire, according to a ruling by the city department of fire prevention, known as the Bureau of Combustibles.

T. H. Parry, general superintendent of the Parry Mfg. Co., and his wife have gone to San Diego, Cal., for the winter months.

# Vehicle Industry News in Brief

## Truck Builders

**United States Motor Truck Co.**, Cincinnati, plans to triple output.

**Indiana Truck Co.**, Marion, will enlarge its plant to provide for a government contract for 500 Liberty trucks.

**Landover Truck Co.**, Menominee, Mich., is now in production and expects shortly to be turning out four trucks per day.

**Service Motor Truck Co.**, Wabash, Ind., will put up two additional buildings to facilitate work on government contracts which the company has.

**Selden Motor Vehicle Co.**, Rochester, has awarded contract for an addition to its plant, 160 x 200 ft., on Probert street, near East avenue, to cost about \$100,000.

**Sanford Motor Truck Co.**, 107 St. Marks avenue, Syracuse, N. Y., has had plans prepared for a one-story factory on West Fayette street, 80 ft. sq., to cost \$9,000.

**Arkansas Motor Truck Co.**, Little Rock, Ark., S. N. Bolton, R. C. Wilson and J. O. Evatt interested, will equip a plant for the manufacture of motor trucks.

**Girnan & Sons Co.**, Eau Claire, Wis., vehicle manufacturer, is planning to build a new factory, garage and machine shop, 45 x 75 x 150 ft., two stories, costing about \$25,000.

**Acme Motor Truck Co.** will hereafter be the name of the manufacturer of the Acme truck in place of Cadillac Motor Truck Co. The offices and plant will remain in Cadillac, Mich.

**Lumb Motor Truck & Tractor Co.**, Aurora, Ill., has been taken over by the Pan-American Motors Corp., Chicago. The truck manufactured by the company will be styled Pan-American.

**Highway Trailer Co.**, Edgerton, Wis., has leased a building adjoining its plant in order to provide capacity for the execution of a government contract for army trailers and airplane transportation trucks.

**Jones Motor Car Co.**, Wichita, Kas., has added two models of trucks and will manufacture 2,000 during 1918. A one-ton model, to sell at \$1,100, will be ready for delivery February 10, and a two-ton model will be on the market by March 1.

**Mutual Truck Co.**, Sullivan, Ind., has elected the following officers: President, Robert Petrie; vice-president, Roy Anderson; second vice-president, J. B. Miller; secretary, Frank McCoy, Effingham, Ill. The company will establish a plant in Sullivan.

**Nelson Bros. Co.**, Saginaw, Mich., has completed its first two-ton "Jumbo" truck and 50 more are planned within the next two months. An addition will soon be made to the factory so that nearly all the units can be manufactured. At present the truck is being assembled.

**Paige Motor Car Co.**, Detroit, has taken over part of the plant of the Williams pickle factory to be used for manufacturing a new motor truck. Steps are being taken

to place the truck in production. It is a two-ton truck and it will be some time before it is placed on the market.

**General Motors Truck Co.**, Pontiac, Mich., will commence the production of the G. M. C. Sampson tractor the latter part of January. This was formerly known as the Sampson Sieve Grip tractor, manufactured at Stockton, Cal. The company was bought out by the General Motors Co. last February and the main plant will be in Pontiac.

**Wisconsin Duplex Auto Co.**, Clintonville, Wis., has completed the first models of its new four-wheel-drive chassis in the plant of the Andrews Motor Mfg. Co., Milwaukee, and is contemplating locating its plant at Oshkosh. The company is capitalized at \$500,000, and was organized by William A. Besserlich, one of the founders of the present Four Wheel Drive Auto Co., Clintonville.

**Hawkeye Mfg. Co.**, which has been making trucks in Sioux City, Ia., for two years, has branched out as the Hawkeye Truck Co., with \$300,000 capital stock. It intends to make an increased number of trucks, and expand into the national field as fast as possible. Officers of the company are: President, R. A. Bennett; vice-president, F. W. Kemp; treasurer, A. T. Bennett; secretary, L. D. Baggs.

**Reliance Motor Truck Co.**, Racine, Wis., is preparing plans for its new plant at Appleton, Wis., to be erected early this year. Details have been modified to provide for a larger initial unit, which will be 75 x 300 ft., one story, with sawtooth roof of reinforced concrete, steel and brick construction. Bids will be taken about January 15 and it is hoped to have the plant ready for operations within 60 or 70 days thereafter.

**Air-O-Flex Corp.**, organized recently at Detroit, Mich., is planning to erect a large factory in which the Air-O-Flex truck fitted with the Air-O-Flex suspension will be manufactured. The factory will be constructed in units with the provision for other units as needed. The complete plan calls for a plant with 300,000 sq. ft. of floor space, exclusive of administration buildings. The first unit, soon to be completed, will contain 100,000 sq. ft., and will provide for a production of ten trucks per day.

**Republic Motor Truck Co.**, Alma, Mich., has received an initial order from H. S. Honingberg & Co., China, for 15 trucks to be shipped immediately. Fifteen others are on their way to Japan, and the company is filling an order for fire trucks to be sent to Manila. The company is preparing for the installation of equipment for its assembling works at Los Angeles. The new plant, it is said, will cost \$100,000 and will be equipped to handle all Pacific coast business. F. W. Ruggles is president.

## Body Builders

**Detroit Weatherproof Body Co.**, Pontiac, Mich., has appointed C. J. Cunningham service manager.



**A. P. Kirby** is in the purchasing department of the airplane division of the Fisher Body Co., having resigned as assistant purchasing manager of the Continental Motors Corp.

**Parry Mfg. Co.**, Indianapolis, which produces bodies, will shortly place on the market a new style farm body. It will fit the Ford one-ton truck chassis and will be 60 in. wide.

**Cleveland (O.) Auto Body & Radiator Co.**, capital \$10,000, to manufacture bodies and radiators, has been incorporated by Lee Oppenheim, Arthur Krause, Josephine Schnuerer, H. A. Rocker and Mathias Gal.

**Commercial Body Co.** is a new corporation in Minneapolis, formed for the purpose of manufacturing commercial bodies. The incorporators are Peter Marschall, A. L. Ditter and L. C. Jefferson. Authorized capital stock is \$50,000.

**Horizontal Hydraulic Hoist & Body Co.**, Milwaukee, has been incorporated with a capital stock of \$50,000 by Edward R. Bacon, Benjamin A. Rees and Charles F. Millmann to manufacture hydraulic hoisting devices and complete dump bodies for motor trucks. Details will be announced later.

**W. S. Seaman Co.**, 480 Virginia street, Milwaukee, manufacturer of automobile bodies, telephone booths, etc., has increased its capital stock from \$50,000 to \$100,000 to accommodate the growth of its business. A branch factory recently was established at 233-257 Clinton street. Irving Seaman is secretary.

**Fisher Body Corp.**, Detroit, in its report for the quarter ending October 31 shows a surplus of \$993,561, a gain of \$246,211 over the preceding quarter; and allowing for dividends on the \$5,000,000 outstanding preferred stock, the available balance for the 200,000 shares of common stock is \$4.53 a share. This is an increase of \$1.24 per share over the preceding quarter.

**Martin Truck and Body Corp.**, York, Pa., has delivered eight ambulances to the New York chapter of the Red Cross, specially constructed on the regular  $\frac{3}{4}$ -ton Atlas truck chassis, 116 in. wheelbase, rear axle construction and Atlas motor. The locker plan is according to Red Cross specifications. Equipment includes electric self-starting and lighting devices and heavy wood artillery type wheels.

**Hale & Kilburn Co.**, Philadelphia, Pa., is to be reorganized and additional working capital secured. \$4,000,000 of new preferred stock is to be authorized, of which \$2,882,266 is to be issued immediately in exchange for old preferred on the basis of \$66  $\frac{2}{3}$  of new for each \$100 of old. Dividends will be cumulative from January 1 at 5 per cent for the present year, 6 per cent for 1919, and 7 per cent thereafter. Plans for offering \$1,000,000 in notes, and for exchanging common stock remain as first discussed. New stock is to be deposited under a voting trust agreement for a period of five years.

### Car Builders

**Templar Motors Corp.**, Cleveland, has awarded a contract for an addition to its plant.

**Willys-Overland, Ltd.**, Weston road, Toronto, contemplates the erection of a factory to cost \$40,000.

**Franklin Automobile Co.**, Syracuse, has orders on its

books that will require six weeks production at full capacity to fill.

**Root & Van Dervoort Engineering Co.** has decided to drop Moline Automobile Co. name. Officers and policies remain unchanged.

**Continental Car Co. of America**, Louisville, has increased its capital from \$20,000 to \$100,000. It has recently been making additions to its plant.

**Studebaker Corp.**, South Bend, Ind., and Detroit, has taken out a permit for a building on East Jefferson avenue, Detroit, to cost \$150,000.

**Cadillac Motor Co.**, Detroit, is working on passenger car production to full capacity, and nearly one-half of the cars produced are of the enclosed type.

**Valley Motor Car Co.**, Clarksdale, Miss., has been incorporated with a capital stock of \$100,000 by its present owners and will enlarge its plant and add new equipment.

**Gillette Motors Co.**, Mishawka, Ind., has been sold to M. W. Mix, president of the Dodge Mfg. Co., and the sale has been approved by the South Bend Circuit Court. Consideration \$151,000.

**Consolidated Motors Co. of America** has been incorporated under Delaware laws with \$10,000,000 capital stock. The incorporators are F. D. Buck, M. L. Horty and K. E. Longfield, all of Wilmington, Del.

**Scripps-Booth Corp.**, manufacturer of the Scripps-Booth automobiles, has passed into the hands of the General Motors Corp. A reorganization of the company is now being made. A. H. Garber, a former Buick man, is now in charge and is expected to be chosen president.

**General Motors Co.** will reopen its plant in Marquette, Mich., January 1, and employ between 1,000 and 1,200 men. The plant, originally built for the Rainier Motor Car Co., has been idle for some time. It will be managed by Geo. H. Hannum, also general manager of the Jackson-Church-Wilcox Co.

**Texas Motor Car Co.**, capital stock \$2,000,000, will probably locate at Dallas. It has \$1,000,000 of capital paid in with which to begin operations. The assembling plant will have a floor space of more than 250,000 sq. ft., and the minimum output, it is stated, will be 6,000 automobiles a year. J. C. Vernon is president.

**Willys-Overland Co.**, Toledo, O., has been making airplane motors, 3 in. gun carriages and army trucks for the government, and is understood to have taken enough additional government orders that, with its production of pleasure cars, will keep the plant at full capacity. The company has leased a manufacturing building at Richmond and Carr streets, Cincinnati, which will be equipped as an assembling plant, and has placed a contract for the erection of an addition to its Elyria, O., plant, to cost about \$69,000.

### Parts Makers

**Mather Spring Co.**, Toledo, O., has awarded a contract for the erection of an addition.

**Sawyer Co.**, Lorain, O., maker of truck parts, contemplates the erection of an addition to its plant.

**Gurney Ball Bearing Co.**, Jamestown, N. Y., has award-

ed contract for an addition, 30 x 256 ft., to its plant on Chandler street.

**Detroit (Mich.) Chassis Co.** is said to be considering the erection of a plant at Bakersfield, Cal., for the manufacture of trucks.

**Thomas Paulson & Son, Inc.**, 97 Second avenue, Brooklyn, operating a brass foundry, is taking bids for a two-story extension 35 x 60 ft.

**Stewart Wire Wheel Corp.**, of Frankfort, Ind., has signed a government contract to manufacture 4,500 wire wheels for airplanes. Approximately \$45,000 is involved in the order.

**E. W. Bliss Co.**, Brooklyn, will erect a new manufacturing building in 53d street, near First avenue, South Brooklyn. It will be seven stories, 200 x 380 ft., and will cost about \$1,400,000.

**Laurel Motors Co.**, Union Building, Anderson, Ind., is preparing to equip a factory for the manufacture of automobile cylinder heads of a new design. It is expected that a new type of motor will also be made.

**Smith Wheel Co.** will increase its capital from \$100,000 to \$3,000,000 and take over the Globe Malleable Iron Co. The latter is the oldest manufacturing plant in Syracuse. Both companies are working on war orders.

**Warner Gear Co.**, Muncie, Ind., will be installed in about two months in a new brick and steel saw tooth roof building, 136 x 450 feet, with wings that bring the total floor area to over 60,000 sq. ft. The present Warner plant contains 93,000 sq. ft. of space, hence the new addition will be a large expansion.

## WANTS

Help and situation wanted advertisements, 1 cent a word; all other advertisements in this department, 5 cents a word; initials and figures count as words. Minimum price, 30 cents for each advertisement.

**Wanted**—Copies of The Hub of May and July, 1916. Must be in good condition. Address Trade News Publishing Co., corner Elm and Duane streets, N. Y. City.

### PATENTS

**Patents**—H. W. T. Jenner, patent attorney and mechanical expert, 606 F St., Washington, D. C. Established 1883. I make a free examination and report if a patent can be had and exactly what it will cost. Send for circular.

### HELP WANTED

**Wanted**—Factory manager, one who has practical experience in building commercial auto bodies and vehicles. Fine opening for right man. Address, Bodies, care The Hub, 25 Elm street, New York.

**Wanted**—Working foreman in woodworking department of custom commercial body factory. Must have ability to do fine work and manage workmen; also some designing ability. Apply Box 888, Ogden, Utah.

### SITUATIONS WANTED

**Wanted**—A position as superintendent, general manager or assistant with some live company in the automobile line. Am a practical body man. Have had vast experience in handling men. Address, Experience, care The Hub.

**Wanted**—Situation by an A1 letterer, capable of taking full charge of lettering department in large auto or wagon manufacturing company. Ellis R. Hohnes, 3640 Shaw avenue, Cincinnati, O.

Leaders in their class for over three-quarters of a century

## FABRICS BRIDGEPORT FABRICS

comprise an elegant assortment of the newest weaves, shades and patterns in automobile upholstery materials

WRITE FOR SAMPLES OF OUR

LIMOUSINE LININGS, CLOTHS, CARPETS, HORSE-HAIR  
CARPETS, CURTAIN SILKS, LACES, SEAT COVER FABRICS

We also supply ROBE RAILS, SPEAKING  
TUBES and TOILET CASES to match upholstery

**BRIDGEPORT COACH LACE CO.**

NEW YORK OFFICE, 1733 BROADWAY

BRIDGEPORT, CONN.

Please mention "The Hub" when you write

The  
**Laidlaw Company**

Inc.  
New York City

.....

**Automobile  
Fabrics**

.....

**A Fabric for  
Every Purpose  
For Closed, Open or  
Convertible Bodies**

**steel  
stampings**

*especially for*  
**COMMERCIAL TRUCKS**

**The Pressed Steel Company  
Wilkes-Barre, Pa.**

**Index To Advertisers**

Barrell Co., Wm. L.....	38
Bliss, E. W., Co.....	3
Bradley, C. C., & Son.....	41
Bridgeport Coach Lace Co.....	35
Century-Plainfield Tire Co.....	39
Century Steel Co. of America, The.....	4
Columbus Bolt Works.....	Back cover
Cowles, C., & Co.....	40
Crane & MacMahon, Inc.....	43
Decker, J. C.....	40
Dixon, Joseph, Crucible Co.....	7
Dowler, Chas. L.....	40
Doxey, N. D.....	39
DuPont Fabrikoid Co.....	38
Eccles, Richard, Co.....	42
G & O Mfg Co.....	43
Gray, Peter, & Sons, Inc.....	41
Hartford Auto Parts Co.....	3
Hotel Rochester .....	41
Johnston, R. F., Paint Co.....	40
Judd & Leland Mfg. Co.....	39
Keratol Co., The.....	38
Laidlaw Co., The.....	36
Mulholland Co., The.....	40
Norton Grinding Co.....	5
O'Banon Corporation.....	Back cover
Parrott Varnish Co., The.....	37
Paulson, Thomas, & Son, Inc.....	Back cover
Pettingell Machine Co.....	6
Pittsfield Spark Coil Co.....	37
Porter, H. K.....	43
Poughkeepsie Utilities Corporation.....	41
Pressed Steel Co.....	36
Quickwork Co., The.....	43
Rome-Turney Radiator Co.....	42
Russell, Birdsall & Ward Bolt & Nut Co.....	41
Sheldon Axle & Spring Co.....	Front cover and 8
Standard Oil Cloth Co., Inc.....	2
Technical School for Automobile Draftsmen and Mechanics .....	38
Wayne Wheel Co.....	37
West Tire Setter Co.....	43
White-Quehl Mfg. Co.....	40
Wilcox Mfg. Co., D.....	43
Wiley Co., C. A.....	42
Wing, Chas., Co.....	40
Yoder Company, The.....	4

Please mention "The Hub" when you write

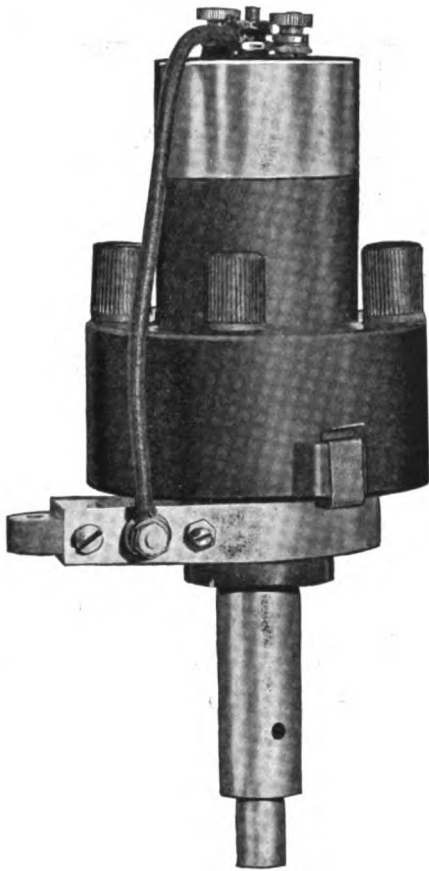

## A Perfectly Synchronized Spark at ALL Speeds

"Pittsfield" Distributor is of unit construction. It has an absolutely mechanical make and break which is positive and independent of spring action. No trips, hammers or other unreliable devices are required or used.

Its make and break is positive, giving a perfectly synchronized spark at all speeds. There is no lag in the spark—no automatic advances required.

Send for folder fully describing the "Pittsfield"

### FORD OWNERS

We have developed a special bracket for installing the "Pittsfield" Distributor on Ford Cars. Send for Folder.

Also manufacturers of "Pittsfield" Coils, Timers, Switches, "Berkshire," "Jewell," and "Micatite" Spark Plugs.

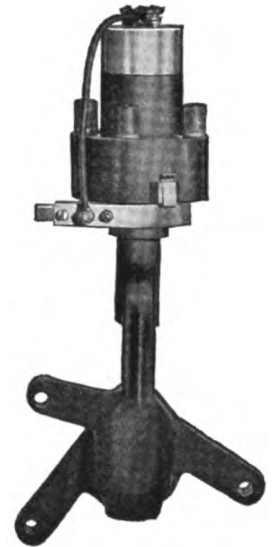

**PITTSFIELD SPARK COIL CO.**  
PITTSFIELD, MASS.

## PARROTT VARNISHES



.. Unequaled for ..

**Automobile  
and  
Carriage  
Finishing**

**The Parrott Varnish Co.**  
Bridgeport, Conn.

## AUTOMOBILE WHEELS

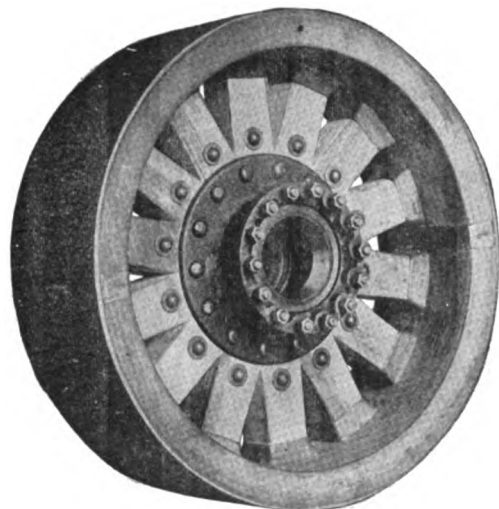

Have you seen our *new* construction?  
Better write us for particulars.

**Wayne Wheel Co.**  
Newark, Wayne Co., New York

# KERATOL LEATHER SKINS

For the car where leather has always been used



PRICE

*Within Reason*

QUALITY

*Maintained*

W<sup>m</sup> L. BARRELL Co. 8 THOMAS ST.  
NEW YORK



REG. U. S. PAT. OFF.

Truck  
Special

As Rugged as the Service  
for Which It Is Made

Behind the firing line or on the busy street  
TRUCK SPECIAL meets every  
test of service.

The United States Government is using leather  
substitutes for Truck Upholstery. You will if you  
investigate the real economy and splendid wearing  
qualities of TRUCK SPECIAL.

Let us send you samples and quote prices

DU PONT  
FABRIKOID CO.

WILMINGTON,  
DEL.



Photograph from Underwood & Underwood, N. Y.

## Vehicle Mechanics

Desiring to improve their present  
Condition should attend the

## TECHNICAL SCHOOL

For

## Automobile Draftsmen and Mechanics

Supported by the

The National Automobile Chamber of Commerce, Inc.

The object of the School is to teach men to design  
vehicles and make working drawings, and to otherwise  
facilitate their work in the shop. Only those men em-  
ployed in carriage or automobile building or their acces-  
sory trades are admitted to its privileges.

The classes are conducted in three divisions, viz.: Cor-  
responding, Day, and Evening. The former is open during  
the entire year, while the day and evening classes are in  
session only from October 1 to April 1.

The tuition is moderate.

For prospectus and full particulars, write to the instructor.

ANDREW F. JOHNSON,  
20 West Forty-fourth St.,  
NEW YORK CITY

Please mention "The Hub" when you write.





# ANCHOR WELDING COMPOUND

MANUFACTURED BY  
**N. D. DOXEY, ELMIRA, N. Y.**

ANCHOR WELDING COMPOUND will weld hardest steel. Will not peel apart at the weld, thus losing the heat, nor burn up when flowing on the lap. Will weld without the use of hammer. Place two flat surfaces together in the fire, smelting the Compound liberally on the parts and press pieces together firmly with tongs, and weld will be complete without a stroke of the hammer. It will not require any iron filings to be added in welding as in some other compounds. It does the work itself. A weld made with ANCHOR COMPOUND leaves the welded parts of equal strength with solid parts of the metal. Cannot be damaged by dampness nor by heat.

Your Welding Compound gives entire satisfaction. In welding steel of high carbon, it fluxes quick and the steel appears like iron, and can be worked at a white heat. I have tried all other compounds in the market and can pronounce yours the best. It flows where you want it to flow.  
C. H. KILMER, Elmira, N. Y.

We take pleasure in stating that we have been using your Welding Compound for several years and find it a most excellent article, and can recommend it highly. Yours truly,  
THE LAFRANCE FIRE ENGINE CO.,  
W. Falck, Gen. Manager, Elmira, N. Y.

Is used by U. S. Navy and C. & N. W. Ry. Co. and many others.

IN USING do not throw the Compound from the surface to be welded, but cup the scarfs, and in light work turn the piece, when ready for welding, so that the Compound will flow evenly over the surface to be welded, which it will readily do, flowing like oil. In heavier work, add compound to surface to be welded, as heat nears welding point, so that surface to be welded is covered with fused compound.

## The Best Hand Pump THE VICTOR



Must have brass tubes that will not rust or cut out the cups.

It must be quick in action. Motorists do not allow for tire troubles in arranging their schedules.

The cups must be of selected leather to give long service.

The design must be simple and easily understood.

This is  
such a pump

NOT BEST BECAUSE IT WAS FIRST  
BUT FIRST BECAUSE IT IS BEST

ASK ABOUT IT OF

**JUDD & LELAND MFG. CO.**  
CLIFTON SPRINGS, N. Y.



# Superbar Tires

"Service Tires"

Made of high grade fabric and best grades of pure rubber to meet the demand of those who seek a good Standard Quality Tire giving maximum amount of service for money invested.

Built by HAND throughout.

SUPERBAR Tires are the result of many years of scientific experimenting and combine quality of material, skill in workmanship and a maximum of road resistance.

Adjusted on 3,500-mile basis. Ford sizes, 4,500-mile basis.

Splendid agency opportunities are available; particulars on request.

## Century-Plainfield Tire Co.

Plainfield, N. J.

Century-Plainfield Tire Company, a subsidiary of the Rubber Metals Corporation, exclusive manufacturers of the Rimco Rubber Products by the Elchemco process

Please mention The Hub when you write

# BUSY BUYERS BRIEFS

## JOHNSTON'S KRAKNO

Color Card Free  
\$3.50 per gallon  
The R. F. Johnston Paint Co.  
Cincinnati, Ohio

**THE CHARLES WING CO.**  
Established 1848  
Manufacturers and Wholesale Dealers in  
**AUTOMOBILE AND CARRIAGE  
HARDWARE AND TRIMMINGS**  
AMESBURY, MASS., U. S. A.

## Why Not Have the Best?

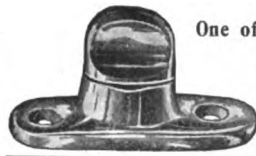

One of a Large Variety

G. Cowles & Co.  
NEW HAVEN,  
CONN.

## J. C. DECKER

MONTGOMERY, PA.  
Manufacturer of  
**Carriage, Skate and Pad Straps**  
Side Loops, Bridle Fronts, Tail Ties, etc.

## CHARLES L. DOWLER

CARRIAGE AND WAGON HARDWARE  
108 North Third St., Philadelphia, Pa.  
**CUSHION MANUFACTURER**  
Pure Stearic Acid Candles. Wheel Stock. Snow  
Flake Axle Grease.

## MULHOLLAND BUGGY SPRING

Reduces weight of springs one-half.  
Made in one size only but will fit bodies  
of all widths.  
Write for further particulars and prices.  
**THE MULHOLLAND CO. DUNKIRK, N. Y.**

## White's Brazing Sleeves



LINED

For applying Rubber Tires  
Send for Samples.



UNLINED

**WHITE-QUEHL MFG. CO.**

431 E. Pearl St.  
CINCINNATI, OHIO

# CLASSIFIED INDEX

For Addresses See Alphabetical Index  
and Advertising Pages

**ANTI-FRICTION METALS**  
Thomas Paulson & Son, Inc.,  
Brooklyn, N. Y.

**AUTOMOBILES**  
American Motors Corp., Plain-  
field, N. J.

**AUTO FABRICS**  
Barrell, Wm. L., Co., New York  
Keratol Co., The, Newark, N. J.  
Laidlaw Co., Inc., The, New  
York.  
O'Bannon Corp., New York City  
Standard Oil Cloth Co., New  
York City.

**AUTO PARTS**  
Hartford Auto Parts Co., Hart-  
ford, Conn.

**AXLES (Including Ball and  
Roller Bearing)**  
Sheldon Axle & Spring Co.,  
Wilkes-Barre, Pa.

**BOLTS AND NUTS**  
Columbus (O.) Bolt Works Co.  
Russell, Burdsall & Ward Bolt  
& Nut Co., Port Chester, N.Y.

**BOLT CLIPPERS**  
Porter, H. K., Everett, Mass.

**BRAZING SLEEVES**  
White-Quehl Mfg. Co. Cincin-  
nati, O.

**DIES**  
Bliss Co., E. W., Brooklyn, N.Y.  
(Sheet Metal Working).

**FORGINGS**  
Eccles, Richard, Auburn, N. Y.  
(Carriage Drop).  
Williams, J. H., & Co. Brook-  
lyn, N.Y. (Automobile, Drop)

**FIFTH WHEELS**  
Wilcox Mfg. Co., D., Mechanics-  
burg, Pa.

**HARDWARE (Carriage, Wagon  
and Automobile)**

Columbus (O.) Bolt Works Co.  
Dowler, Chas. L., Philadelphia,  
N. Y.  
Eccles Co., Richard, Auburn,  
N. Y.  
Wilcox Mfg. Co., D., Mechan-  
icsburg, Pa.  
Wing Co., Chas., Amesbury,  
Mass.  
Cowles, C., & Co., New Haven,  
Conn.

**LEATHER SUBSTITUTES**  
Barrell Co., Wm. L., New York.  
DuPont Fabrikoid Co., Wil-  
mington, Del.  
Keratol Co., The, Newark, N. J.  
O'Bannon Corp., New York City  
Standard Oil Cloth Co., New  
York.

**LUBRICANTS**  
Dixon, Jos., Crucible Co., Jer-  
sey City, N. J.

**MACHINERY AND TOOLS**  
Bliss Co., E. W., Brooklyn, N.Y.  
Norton Grinding Co., Worces-  
ter, Mass.  
Pettingell Machine Co., Ames-  
bury, Mass.  
Simmons Machine Co., Inc.,  
Albany, N. Y.; Singer Bldg.,  
New York City.  
Smith, H. Collier, Detroit, Mich.  
West Tire Setter Co., Roches-  
ter, N. Y.  
Williams, J. H., & Co., Brook-  
lyn, N. Y.  
White-Quehl Mfg. Co., Cincin-  
nati, O.  
Yoder Co., The, Cleveland, O.

**MACHINERY (Metal Working)**  
Bliss Co., E. W., Brooklyn, N.Y.  
Pettingell Machine Co., Ames-  
bury, Mass.  
Quickwork Company, Detroit,  
Mich.  
Yoder Co., The, Cleveland, O.

**METAL STAMPINGS AND  
NOVELTIES**  
Gray, Peter, & Sons, Inc., Cam-  
bridge, Mass.  
Pressed Steel Co. of New York,  
New York City.

**PATENTS**  
Jenner, H. W. T., Washington,  
D. C.

**PAINTS AND COLORS**  
Johnston Paint Co., R. F., Cin-  
cinnati, O.  
Pierce Co., F. O., New York.  
Willey Co., C. A., Hunter's  
Point, N. Y.

**PRESSES**  
Bliss Co., E. W., Brooklyn, N.Y.  
(Drop, Power).

**RADIATORS**  
G. & O. Mfg. Co., New Haven,  
Conn.  
Rome-Turney Co., Rome, N. Y.

**SCHOOL FOR DRAUGHTS-  
MEN**  
Mechanics' Institute, New York

**SHAFT COUPLINGS**  
Bradley & Son, C. C., Syracuse,  
N. Y.  
Eccles Co., Richard, Auburn,  
N. Y.

**SPARK COILS**  
Pittsfield Spark Coil Co., Pitts-  
field, Mass.

**SPRINGS**  
Mulholland Co., Dunkirk, N. Y.  
Sheldon Axle & Spring Co.,  
Wilkes-Barre, Pa.

**STEEL**  
Century Steel Co. of America,  
Poughkeepsie, N. Y.; Sales  
office, 120 Broadway, N. Y.

**TIRES**  
Century-Plainfield Tire Co.,  
Plainfield, N. J.  
**TIRE PUMPS**  
Judd & Leland Mfg. Co., Clifton  
Springs, N. Y.

**TOOLS**  
Williams, J. H., & Co. Brook-  
lyn, N. Y.

**TRIMMING MATERIAL**  
Bridgeport (Conn.) Coach Lace  
Co.  
Decker, J. C., Montgomery, Pa.  
Wing Co., Chas., Amesbury,  
Mass.

**UNIVERSAL JOINTS**  
Hartford (Conn.) Auto Parts  
Co.

**VARNISH AND JAPAN**  
Parrott Varnish Co., Bridgeport,  
Conn.  
Pierce Co., F. O., New York.  
Willey Co., C. A., Hunter's  
Point, N. Y.

**VARNISH RENOVATOR**  
Poughkeepsie (N. Y.) Utilities  
Corp.

**WELDING COMPOUND**  
N. D. Doxey, Elmira, N. Y.

**WHEELS**  
Crane & MacMahon, Inc., New  
York City.  
Hoopes Bros. & Darlington,  
Inc., West Chester, Pa.  
Wayne Wheel Co., Newark, N.J.

**WOOD BENDINGS, WHEEL  
STOCK, ETC.**  
Crane & MacMahon, Inc., New  
York City.

Please mention "The Hub" when you write

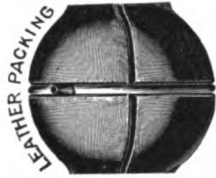

The Only  
One-piece  
Moulded  
Leather Packing

# The Bradley Carriage Coupler

All-Steel Noiseless Quick-Shifting Ball-Bearing

(MADE IN FIVE SIZES FOR AXLES 3/4 INCH TO 2 1/4 INCH)

The *only* carriage coupler that is furnished with a ONE-PIECE MOULDED LEATHER PACKING

C. C. BRADLEY & SON, Syracuse, N. Y.



The Bradley Carriage Coupler

## HOTEL ROCHESTER

Rochester, N. Y.

"A Tone All Its Own"



300 Rooms with Bath

One of the Finest Equipped Hotels in the World  
EUROPEAN PLAN \$1.50 UP  
Club Features in Restaurant

MILTON ROBLEE, Manager

## Sheet Metal Specialties



WE are in a position to furnish *Sheet Metal Stampings* in all kinds of metal at the rate of several hundred thousand pieces per day.

Special attention given to rush orders. Send us your inquiry with specifications.

**Peter Gray & Sons, Inc.**  
Cambridge, Mass.

## UTILITY VARNISH RENOVATOR

"The ONE that WILL"

Preserve the fine finish of your automobile

ECONOMICAL TO USE  
EASY TO APPLY  
EFFECTIVE IN RESULTS

FOR SALE BY GARAGES, AUTO ACCESSORY AND HARDWARE STORES

Manufactured by

**POUGHKEEPSIE UTILITIES CORP., 46 Winnikee Ave., Poughkeepsie**

## RUSSELL, BURDSALL & WARD BOLT & NUT CO.

Established 1845

PORT CHESTER, N. Y.

**MAKERS OF THE CELEBRATED EMPIRE BOLTS AND NUTS**

Western Office: Continental & Commercial Bank Bldg., Chicago, Ill. Branch Works: Rock Falls, Ill.

Please mention "The Hub" when you write

# RADIATOR INSURANCE

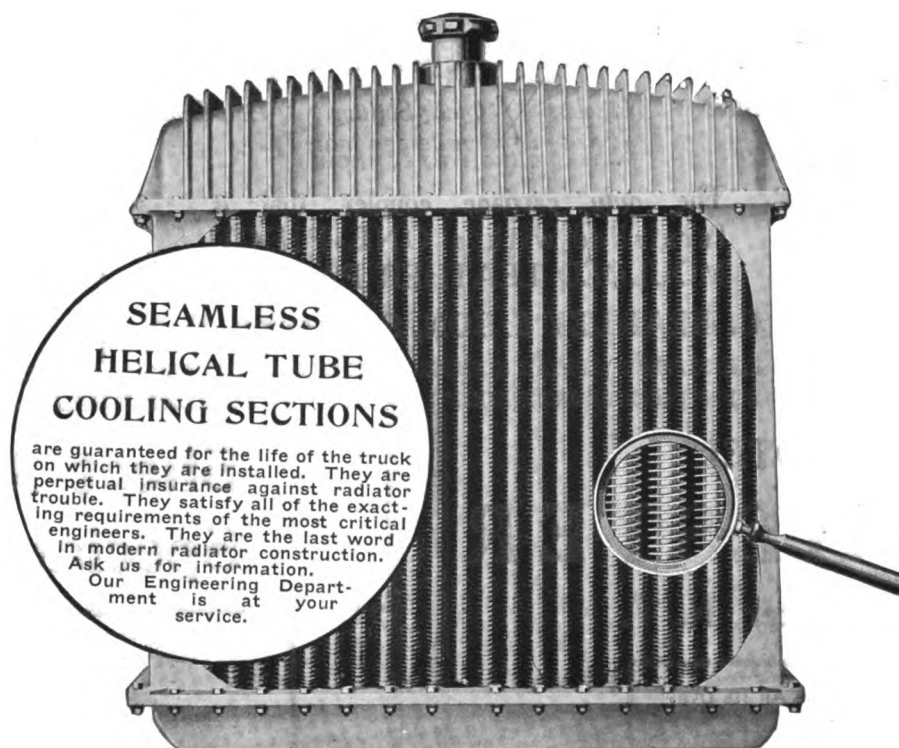

ROME-TURNEY RADIATOR CO., Sole Manufacturers, ROME, N. Y.

## WILLEY'S COLORS

The Recognized Standard



**C. A. WILLEY CO.**

**COLOR GRINDERS**

and Manufacturers of Specialties in

**CARRIAGE, AUTOMOBILE and CAR**

**PAINTS**

**COLORS, VARNISHES, ETC.**

**HUNTER'S POINT, NEW YORK CITY**

## Automobile, Carriage, Wagon and Special FORGINGS

of Guaranteed Quality

When you are in the market, send us your blue-prints for quotations.

Ask for catalog showing part of our large line of Automobile and Special Forgings, also catalog listing our full line of Carriage and Wagon Hardware.

**Richard Eccles Co.**

**AUBURN, NEW YORK**

ESTABLISHED IN 1880

# AUTOTRUCK

## Hickory Nut and

BEST QUALITY STOCK  
TOUGH AND HEAVY  
BONE DRY

MANUFACTURED BY  
CAPABLE MECHANICS  
AND MOST  
IMPROVED MACHINERY

WHEELS WHICH ADD TO  
THE LIFE OF YOUR TRUCK

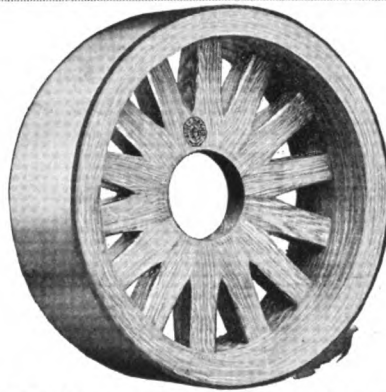

# WHEELS

## Acorn Brands

HORSE-DRAWN  
VEHICLE WHEELS  
ALL STYLES

TRAILER WHEELS:  
SARVEN AND  
ARTILLERY TYPES

HIGH STANDARD OF  
QUALITY AND  
WORKMANSHIP  
MAINTAINED

ST. MARYS, OHIO

CRANE & MacMAHON, Inc.

8 BRIDGE ST., N. Y. CITY

# WILCOX

FINE  
FINISHED  
FORGED

## CARRIAGE HARDWARE AND GEAR IRONS

Write for Prices and Catalog

### The D. Wilcox Mfg. Co.

MECHANICSBURG, PA.

## The WEST Hydraulic Tire Setter

### WILL CUT DOWN EXPENSE

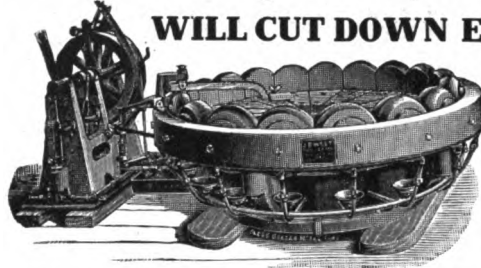

Tires set cold in one minute. This machine saves time—does the work better and quicker, does a way with burned streaks. Only necessary to measure one wheel in a lot. Does not char the rim, and

thus make the tire loosen prematurely. Saves resandpapering of wheels. This machine is now increasing the profits of many manufacturers. Send for catalog and read about it.

WEST TIRE SETTER CO., ROCHESTER, NEW YORK

## PORTER'S BOLT CLIPPERS

"Easy" "New Easy" Allen-Randall



To Cut 5-16, 3-8, 1-2, 5-8, 3-4 Inch.

H. K. PORTER, EVERETT, MASS.

## "Quickwork"

### Sheet Metal Working Machinery

For Automobile and Carriage Bodies, Fenders, Hoods, etc.

## THE QUICKWORK CO.

H. COLLIER SMITH, Pres. and Gen. Mgr. ST. MARYS, O.

# Results Always Follow Advertising in THE HUB

# It Pays Others It Should Pay You



ENGINE COOLING

# RADIATORS

FOR PLEASURE CAR AND HEAVY DUTY SERVICE

G & O MFG. CO. - New Haven, Conn.



## The Hub

The machinery of the country is running at top speed to supply war needs. Machines are supplementing man power to make up for labor



shortage. The wheels **MUST** be kept turning—automobiles, gas, oil and steam engines, railway trucks, generators and everything that runs in bearings.

# “HECLA” ANTI-FRICTION BRONZE

will keep them moving, smoothly and efficiently. This alloy is the result of 32 years' experience and research. “HECLA” WILL NOT CUT the journal or pin under the severest service conditions. Will not pound out or break, MACHINES CHEAPLY and has NO SUPERIOR regardless of price. Let us send the little “Hecla” booklet. We also make Castings—finished or rough, in Brass, Bronze, Aluminum, Hydraulic Metals, Copper, Acid Metal.

**BRASS FOUNDERS  
ENGINEERS**

**THOMAS PAULSON & SON, Inc.**

**97 SECOND AVENUE  
BROOKLYN, N. Y.**

**O'BANNON**

**COATED FABRICS**

*Variety of Qualities*

WRITE FOR SAMPLES

**O'BANNON CORPORATION**  
200 FIFTH AVE. NEW YORK

THE IDEAL TOP MATERIAL

THE SUPERIOR LEATHER SUBSTITUTE

**O'BANNON INTERNATIONAL**

**O'BANNON LEATHER**

### Skewed Shaft Couplings

**Regular or Oval Patterns  
For High Arched Axles**

Furnished in rights and lefts for any height of arch.  
Oval Axle Clips  $\frac{5}{8}$  or  $\frac{3}{4}$  width to match Oval  
Couplings. Bolts, Clips, Couplings, Carriage  
Hardware and Special Forgings

Catalogue “H” and Prices on Application

**COLUMBUS BOLT WORKS COMPANY**  
COLUMBUS, OHIO

# The Hub

First Journal of the Vehicle Industry

Vol. LIX

NEW YORK, FEBRUARY, 1918

No. 11

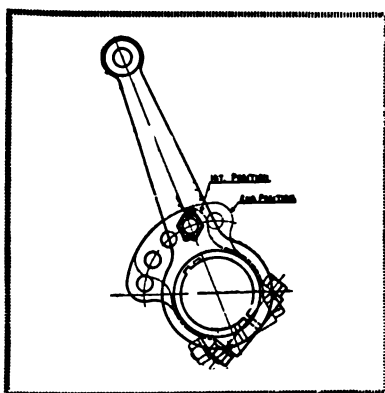
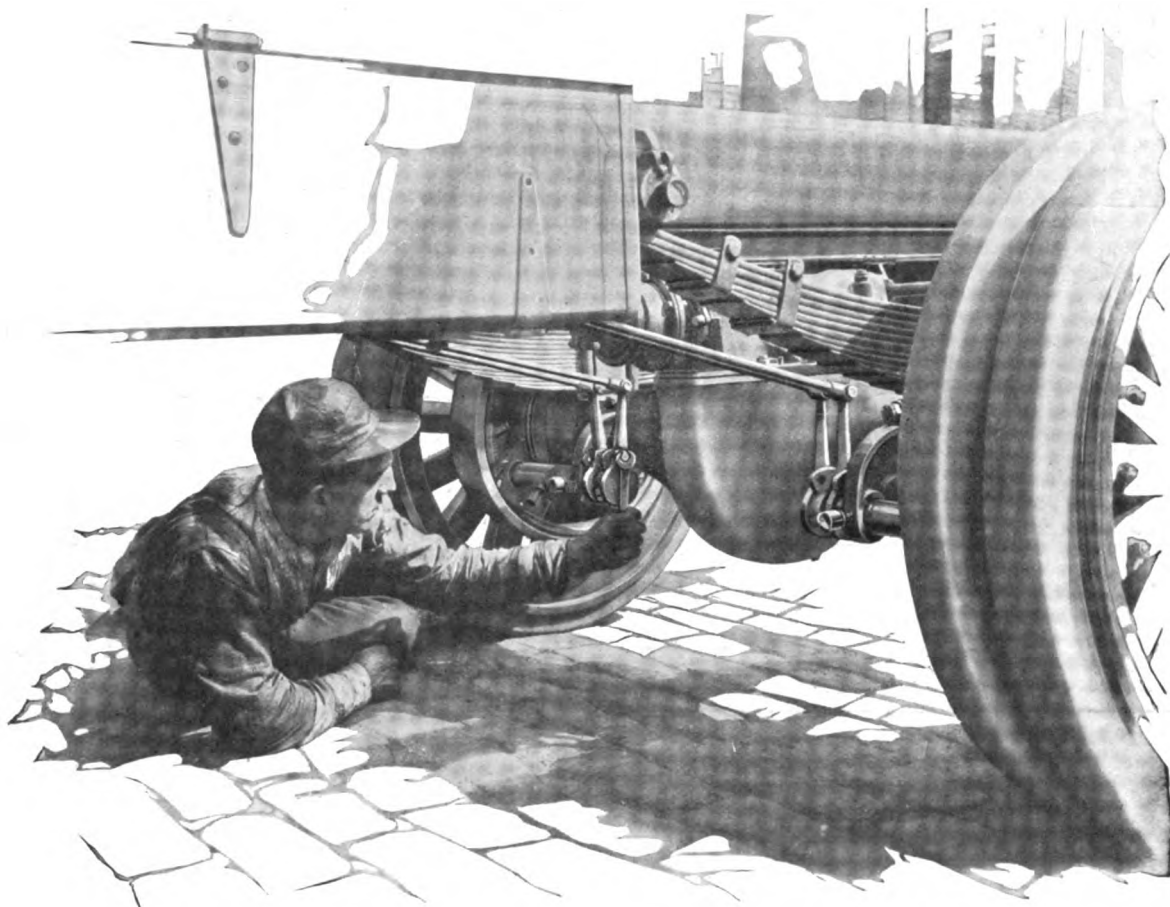

The adjustment is made by a sector attached to the brake pull lever. To tighten up on the brake levers simply take out the bolt which fastens this sector to the lever, and move the hole in the lever backwards one hole on the sector.

## FOR INSTANCE

Note the provision for adjusting the brakes on the Sheldon Worm Gear Semi-floating Rear Axle. It is not necessary to touch the brakes themselves. Just move back the sector to which the brake pull lever is bolted and insert the lever bolt in the next hole. Simple— isn't it? and quick. Minute saving and money saving.

It is this accessibility of parts, this amazing refinement of every feature to best meet the demands of service that one finds the keynote of Sheldon supremacy.

Write for further Sheldon information.

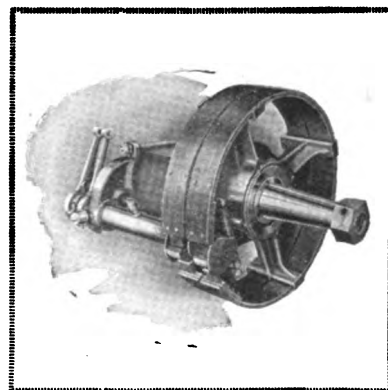

Note accessibility and simplicity of adjustment

# SHELDON



## WORM GEAR AXLES



SHELDON AXLE AND SPRING CO.

Makers of springs and axles for heavy duty service for more than fifty years

WILKES-BARRE, PA.

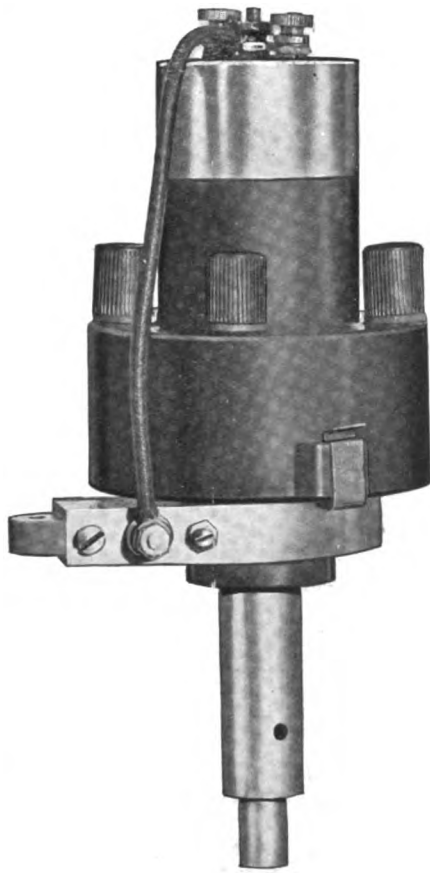

## A Perfectly Synchronized Spark at ALL Speeds

"Pittsfield" Distributor is of unit construction. It has an absolutely mechanical make and break which is positive and independent of spring action. No trips, hammers or other unreliable devices are required or used.

Its make and break is positive, giving a perfectly synchronized spark at all speeds. There is no lag in the spark—no automatic advances required.

Send for folder fully describing the "Pittsfield"

### FORD OWNERS

We have developed a special bracket for installing the "Pittsfield" Distributor on Ford Cars. Send for Folder.

Also manufacturers of "Pittsfield" Coils, Timers, Switches, "Berkshire," "Jewell," and "Micatite" Spark Plugs.



**PITTSFIELD SPARK COIL CO.**  
PITTSFIELD, MASS.

## PARROTT VARNISHES



.. Unequaled for ..

**Automobile  
and  
Carriage  
Finishing**

**The Parrott Varnish Co.**  
Bridgeport, Conn.

## AUTOMOBILE WHEELS

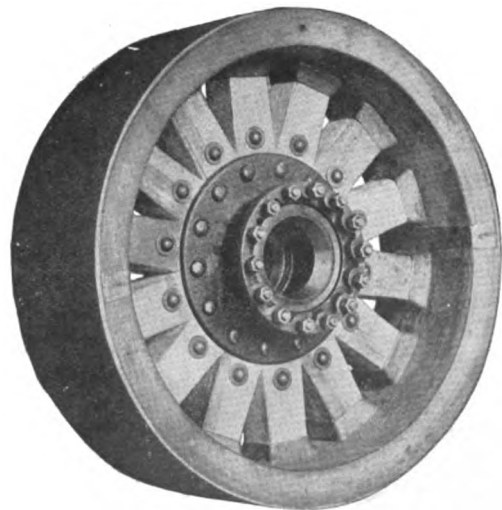

Have you seen our *new* construction?  
Better write us for particulars.

**Wayne Wheel Co.**  
Newark, Wayne Co., New York

Please mention The Hub when you write

Leaders in their class for over three-quarters of a century

# FABRICS BRIDGEPORT FABRICS

comprise an elegant assortment of the newest weaves, shades and patterns in automobile upholstery materials

WRITE FOR SAMPLES OF OUR

LIMOUSINE LININGS, CLOTHS, CARPETS, HORSE-HAIR  
CARPETS, CURTAIN SILKS, LACES, SEAT COVER FABRICS

We also supply ROBE RAILS, SPEAKING  
TUBES and TOILET CASES to match upholstery

## BRIDGEPORT COACH LACE CO.

NEW YORK OFFICE, 1733 BROADWAY

BRIDGEPORT, CONN.

**Hartford**  
Universal Joints

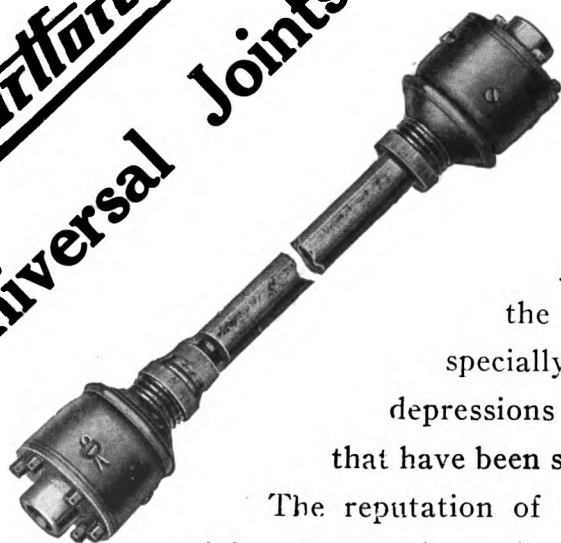

WE are able to offer manufacturers universal joints manufactured by specialists in one of the largest plants in the world.

The wearing surfaces of HARTFORD UNIVERSAL JOINTS are hardened and ground, the grinding being accomplished by a specially devised machine whose use eliminates depressions or elevations so common in steel parts that have been simply reamed.

The reputation of your car demands the best universal joints that can be made, and we have them.

# The Hartford Automobile Parts Co.

Established 1906

Hartford, Conn.

Please mention "The Hub" when you write.

# Yoder Sheet Metal Machinery

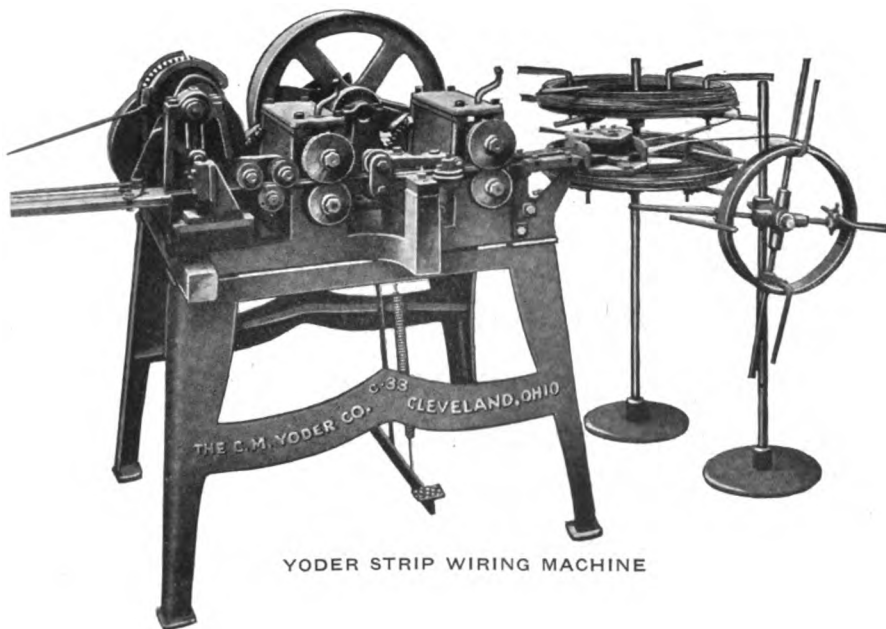

YODER STRIP WIRING MACHINE

Our line of Auto Sheet Metal Working Machinery is efficient in every detail.

Every machine is constructed with the objective of producing perfect results at a minimum cost of material and labor.

The Yoder Company guarantees its machinery to produce results satisfactory to the purchaser.

We are glad to consider your Sheet Metal Machinery needs, as well as your requirements for special machines.

If you are thinking of making your own sheet metal parts or producing sheet metal products for the trade, get in touch with us at once. We can save you money and furnish a most satisfactory and complete equipment.

Catalog and prices furnished on request

## THE YODER COMPANY

Engineers Building

CLEVELAND, OHIO

# CENTURY

"C. T. V. No. 5"

## Tungsten Valve Steel

Regular Analysis or to Special Analysis for  
TOUGHNESS RIGIDITY HIGH HEAT RESISTANCE

## THE CENTURY STEEL CO. OF AMERICA

Manufacturers of High-Grade Crucible Steels

General Office and Works:  
POUGHKEEPSIE, N. Y.

CHICAGO SALES OFFICE:  
E. P. Bartlett & Co., 15 N. Jefferson Street

PHILADELPHIA SALES OFFICE:  
Century Steel Co. of America, Real Estate Trust Bldg.

CLEVELAND SALES OFFICE:  
J. E. Rawson, Rose Building

NEW YORK SALES OFFICE:  
Century Steel Co. of America, 120 Broadway

Please mention The Hub when you write





# NORTON

## NORTON

### Quick, Accurate, Profitable Crankshaft Grinding

In answering the nation's call for speedy production Norton Grinding Machines are in the forefront.

Automobile Builders as well as manufacturers in other fields were quick to realize the speed, accuracy—and profit, too, resulting from the use of Norton Grinders.

In grinding crankshafts large or small, from roughing to finishing, the Norton saves many valuable minutes—when minutes count for so much.

The illustration shows a small air compressor pump crankshaft both roughed and finished on a Norton. The shaft is about .680 in. in the rough. About .120 in. is removed in the first operation and .008 in. in the second.

About 40 ends or 40 throws per hour are roughed and the same number finished in about the same time.

Our Service Department is always ready to help you with your grinding problems; consult them freely.

## NORTON GRINDING COMPANY

Worcester, Massachusetts

Chicago Store: 11 North Jefferson Street

Vonnegut Machinery Co., Indianapolis, Ind.  
Robinson, Cary & Sands Co., St. Paul and  
Duluth, Minn. Manning, Maxwell Moore,  
Inc., St. Louis, Mo. Henry Prentiss Co.,  
New York, N. Y.; Boston, Mass.; Buffalo,  
N. Y.; Rochester, N. Y.; Syracuse, N. Y.;  
Scranton, Pa. The Mott & Merryweather  
Machinery Co., Cleveland, O.; Detroit, Mich.;  
Pittsburgh, Pa.; Cincinnati, O. Eccles &  
Smith Co., San Francisco, Cal.; Los Angeles,  
Cal.; Portland, Ore. The Canadian Fair-

banks-Morse Co., Ltd., Montreal, Que.; To-  
ronto, Ont.; Vancouver, B. C. C. T. Patter-  
son Co., Ltd., New Orleans, La. Kemp  
Machinery Co., Baltimore, Md. W. E. Ship-  
ley Machinery Co., Philadelphia, Pa. English  
Tool & Supply Co., Kansas City, Mo. Alfred  
Herbert, Ltd., Coventry, Eng.; Paris, France;  
Milan, Italy. Post Van der Burg & Co.,  
Rotterdam, Holland. The F. W. Horne Co.,  
Tokio, Japan. Iznoskoff & Co., Petrograd,  
Moscow and Ekaterinburg.

# RADIATOR INSURANCE

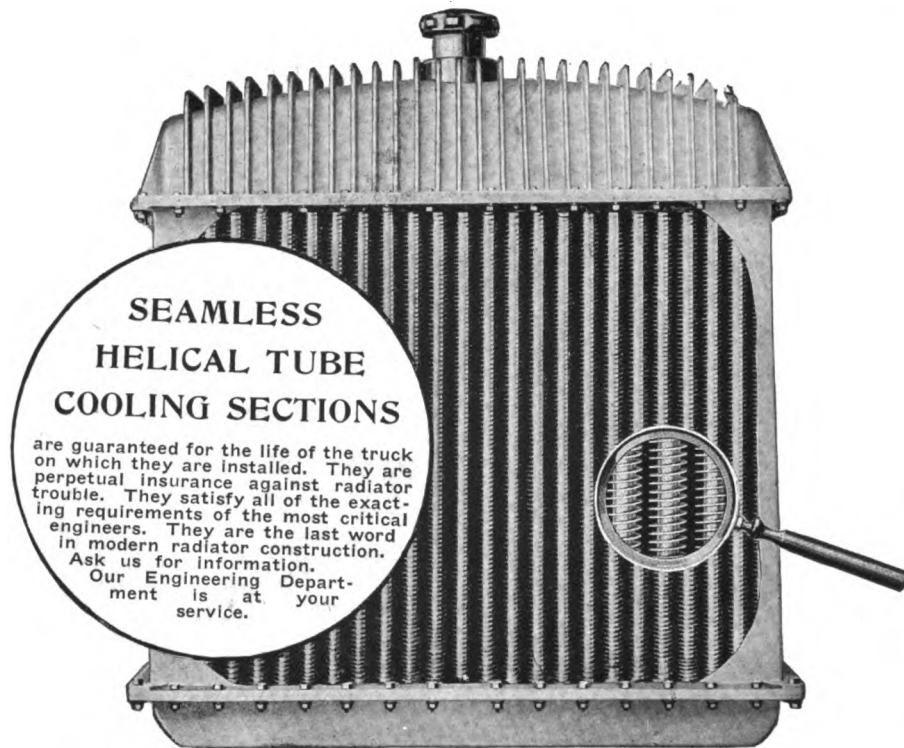

**ROME-TURNEY RADIATOR CO., Sole Manufacturers, ROME, N. Y.**

## WILLEY'S COLORS

The Recognized Standard



**C. A. WILLEY CO.**

**COLOR GRINDERS**

and Manufacturers of Specialties in

**CARRIAGE, AUTOMOBILE and CAR**

**PAINTS**

**COLORS, VARNISHES, ETC.**

**HUNTER'S POINT, NEW YORK CITY**

## Automobile, Carriage, Wagon and Special **FORGINGS**

of **Guaranteed Quality**

When you are in the market, send us your blue-prints for quotations.

Ask for catalog showing part of our large line of Automobile and Special Forgings, also catalog listing our full line of Carriage and Wagon Hardware.

**Richard Eccles Co.**

**AUBURN, NEW YORK**

ESTABLISHED IN 1880

Please mention "The Hub" when you write



## This Booklet Shows You the Way to Better Lubrication

It tells you clearly, entertainingly, convincingly what causes Friction.

It explains how graphite lubrication is the best method to combat Friction's constant wear and tear on your car.

It demonstrates how

**DIXON'S**  
GRAPHITE  
Automobile  
**LUBRICANTS**

put Friction to rout and help your peace-of-mind and pocketbook.

It shows the many uses of Dixon's and how to use the right kind in the right place in motor car, motor boat or motorcycle.

*Write for copy of this most instructive and helpful booklet No. 123-G*

**JOSEPH DIXON CRUCIBLE COMPANY**



Jersey City, New Jersey  
Established 1827



# SHELDON

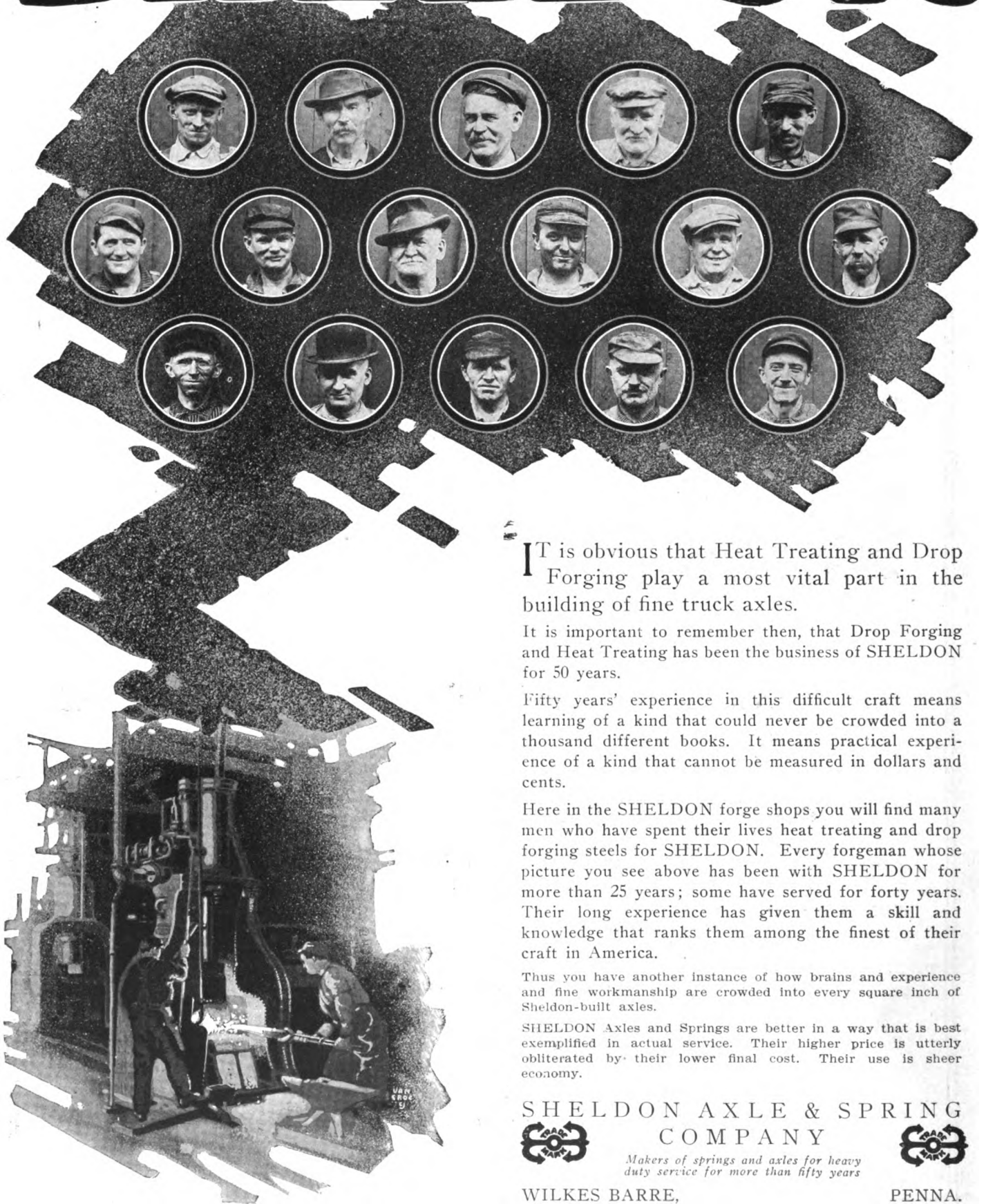

IT is obvious that Heat Treating and Drop Forging play a most vital part in the building of fine truck axles.

It is important to remember then, that Drop Forging and Heat Treating has been the business of SHELDON for 50 years.

Fifty years' experience in this difficult craft means learning of a kind that could never be crowded into a thousand different books. It means practical experience of a kind that cannot be measured in dollars and cents.

Here in the SHELDON forge shops you will find many men who have spent their lives heat treating and drop forging steels for SHELDON. Every forgerman whose picture you see above has been with SHELDON for more than 25 years; some have served for forty years. Their long experience has given them a skill and knowledge that ranks them among the finest of their craft in America.

Thus you have another instance of how brains and experience and fine workmanship are crowded into every square inch of Sheldon-built axles.

SHELDON Axles and Springs are better in a way that is best exemplified in actual service. Their higher price is utterly obliterated by their lower final cost. Their use is sheer economy.

SHELDON AXLE & SPRING  
COMPANY



Makers of springs and axles for heavy  
duty service for more than fifty years



WILKES BARRE,

PENNA.

Please mention "The Hub" when you write



# The Hub

Vol. LIX

NEW YORK, FEBRUARY, 1918

No. 11

Published Monthly by

## THE TRADE NEWS PUBLISHING CO. OF N. Y.

PAUL MORSE RICHARDS, *President* G. A. TANNER, *Secretary and Treasurer*  
EDISON BUILDING, COR. ELM AND DUANE STS., NEW YORK

THE HUB, a monthly authoritative journal on all subjects pertaining to the vehicle industry from its engineering and construction viewpoints. It publishes information of live interest to manufacturers of motor vehicles, trailers, carriages, wagons, the accessory trades, repair shops and garages.

Subscription price for the United States, Mexico, Cuba, Porto Rico, Guam, the Philippines, and the Hawaiian Islands, \$2.00; Canada, \$2.50; payable strictly in advance. Single copies, 25 cents. Remittances at risk of subscriber, unless by registered letter, or by draft, check, express or post-office order, payable to the order of THE TRADE NEWS PUBLISHING CO.

For advertising rates apply to the publishers. Advertisements must be acceptable to publishers. Copy for new advertisements must be received by the 25th of the preceding month. All communications must be accompanied by the full name and address of writer.

Entered in the New York Post Office as Second-class Matter

## Keep the U. S. United

What unites the United States?

The paramount necessity of national solidarity makes the answer to this question of vital importance at this time. Physical union has been accomplished through the means of railroads, which have destroyed the immobility of people and things and given us national highways for the interchange of commodities.

Beyond and above this, however, is the unity which is the product of common ideals, uniformity of education and singleness of purpose. Without these attributes even the interchange of commodities would become difficult, for before a sale can take place there must be an interchange of ideas, of information. People do not think together, do business together, act together and fight together, unless they are bound together by a common bond of sympathy, which is only possible through a free interchange of ideas, through a sympathetic understanding of each other's problems and the general dissemination of information on an equitable basis to all citizens.

Yet the United States stands face to face with a possible disruption of its established channels of intelligence and information, because, beginning July 1, the postal charges on newspapers and periodicals will be increased from 50 to 900 per cent. This act further provides for the division of the United States into a series of eight zones, with progressively higher rates up to the last zone, in which the rate will be 10 cents per pound, or \$10 per hundredweight.

We bring this subject to the attention of our readers, not because of selfish reasons; these are entirely secondary. We are addressing you now in the discharge of our

duty as publicists and patriots, rather than as business men threatened with an unfair discriminatory and destructive tax burden.

The effect of this measure upon you, upon the general welfare of our country, is the only issue at stake, though it is hard to overlook the just claims of thousands of employees who have already voiced their protest, or the many worthy publications which will be crushed by this reactionary legislation.

It seems strange that the United States must put in a postal rate from eight to forty times higher than the present rate in Canada, and rates that are higher than those in existence in any modern country under peace or war conditions. Furthermore, these rates will average nearly three times higher than the rates in effect prior to 1885, when Congress voluntarily established the uniform flat rate of a cent a pound on second-class matter.

Back in 1846 we had zone rates on letters as well as on periodicals, and this operated to prevent the free interchange of thought between the different sections of the United States. It made Mason and Dixon's line a real barrier between the north and the south. In 1863, Abraham Lincoln recommended and Congress enacted a flat rate on letters to all parts of the United States, irrespective of persons or places.

This measure the great Lincoln clearly saw was the first step toward creating a real union between all states and all citizens. Carrying out this sound principle, Congress in 1879 established a flat uniform rate on newspapers and periodicals. Since then world wide uniform rates have been established on letters and periodicals by all modern nations. The whole tendency has been toward the removal of natural or artificial barriers in the way of cheap and easy intercourse between the states, between nations.

Now, after the passage of more than a generation, and facing the most critical period of our history, we have gone back to old, discarded and discredited postal principles. We have again established conditions that will produce, not one, but eight Mason and Dixon lines.

It is, indeed, hard to believe that enlightened American people will approve of this antiquated and iniquitous plan for chopping up our country; we are confident that they will not sanction a policy of postal aggression and suppression, and that they will demand a restoration of the right of free and unobstructed intercourse between the states and between all sections without prejudice to any section or any class.

The excuse offered that this is a war tax is effectually disposed of in the Postmaster's annual report, in which he makes the admission that it is a permanent adjustment of postal rates. If it was a tax there would be no justifi-



cation for imposing extra, super-taxes upon a business hard hit by excessive publishing costs, and which will pay under the other sections of the war revenue bill proportionately more taxes than other classes of business.

But there are "economic illiterates" in Congress who prattle about low rates of postage being a "subsidy" to publishers. Any high school student of economics knows that low freight charges are primarily of benefit to consumers.

Are low freight rates on grain a "subsidy" to farmers?

Are free libraries a "subsidy" to publishers?

Are free highways a "subsidy" to vehicle owners?

Who would suffer the most if the freight rates on iron and steel articles should be raised 900 per cent—an unthinkable disaster, yet that is the percentage of increase on publications going into the eighth zone under this unspeakable postal law.

The only two impartial postal commissions of recent years, the Hughes Commission and the Penrose-Overstreet Commission, denounced the zone system of rates on periodicals as unwise, impracticable and undemocratic.

Woodrow Wilson said a few years ago, in condemning a pending bill similar to the one in question:

"It must be that those who are proposing this change of (postal) rates do not comprehend the effect it would have. A tax upon the business (advertising) of the more widely circulated magazines and periodicals would be a tax upon their means of living and performing their functions.

"This proposed new postal rate would be a direct tax, and a very serious one, upon the formation and expression of opinion—its more deliberate formation and expression, just at a time when opinion is concerning itself actively and effectively with the deepest problems of our politics and our social life.

"To make such a change now, whatever its intentions in the minds of those who propose it would be to attack and embarrass the free processes of opinion. Surely sober second thought will prevent any such mischievous blunder."

If, in the words of Woodrow Wilson, it was a "mischievous blunder" before the war what is it now?

You may well ask in wonderment, how in the name of common sense did such vicious piece of legislation get through Congress? It was slipped in as a "rider" to the War Revenue Bill, and jammed through the Conference Committee, after its rejection by an overwhelming vote in the Senate. Bills without legs to stand on have to become "riders" on the broad backs of urgent and legitimate legislation.

Senator Smoot has already introduced a bill repealing this system of postal rates, which would compel knowledge to travel upon a mileage ticket and hurdle higher and higher zone fences every few miles. The Smoot Bill (S-2985) deserves the active support of every citizen who realizes the need for national unity and the dangers of sectionalism. It has the support of all men who know what the agricultural press means to the farmers who know the indispensable part played by trade and technical papers in promoting better methods of production and distribution, by those who appreciate the cultural value of the home reading circle, by mothers who know what they owe to women's papers, by doctors, engineers, scientists and professional men of all kinds to whom the peri-

odical of their class is a perennial post-graduate college course.

We believe and earnestly hope that every intelligent American will count it a privilege as well as a duty to write their Senators and Congressmen in vigorous protest against this attempt to cripple or destroy the periodical press of the country, and we sound this warning and make this suggestion wholly in the interest of the general welfare.

### Trade Conditions in Australia

A representative of a leading Australian motor importing firm, who recently went to England, has sent out to his firm some interesting particulars of the conditions of the motor industry at home and on the continent. He writes:

"In far-off Australia one does not realize the changes brought about by the war. It came as a shock to me. In the first place, the manufacture of chassis, except for war purposes, is entirely at a standstill. New chassis are unobtainable at whatever figure you may care to offer for them, and the few second hand cars which are to be found on the market command prices which would be deemed ridiculous at any other time than now. A second hand Hotchkiss car, 18-22 h.p., 1914 model, with torpedo body, which has been in service consistently for three years, brought an offer of £1,000, and the owner would not sell. He wants £1,120, and is sure he will obtain it. I must say that Hotchkiss in France enjoys a reputation like that of Rolls Royce in England. A Rolls of mature age, with a first class limousine body, would easily fetch \$2,400 here at the present time, and all other makes are similarly situated.

"As regards the manufacturers, they are, one and all, occupied with the manufacture of war material. To endeavor to talk to them of ordinary trade is to invite premature old age, and to come to them with complaints, claims, and requests for concessions is almost dangerous. There can be no question of discourtesy in their attitude. As long as there is a war, and the issue hangs in the balance, they cannot, and will not, talk trade, and one quickly appreciates their point of view, as things on this side are not as easy-going as they are at your end. Even information as to what will take place after the war is unobtainable. Nobody willingly thinks of after the war, as social changes and other factors will operate most powerfully. It will take a long time for things to settle down, and, therefore, no plans are laid yet for the future. The manufacturers live in the present. They do not want the past raked up, and they cannot anticipate the future.

"The increase in the cost of raw material is well nigh unbelievable, and yet steel and all metals are continually going up, thereby compelling the manufacturers to increase their prices. Labor also is paid three times as much or more than it was before the war, so that the various governments have to pay high prices for whatever they buy. Such is the situation in its principal lines, and it means that, until the war is over, or, rather, until enough time has elapsed for Europe to settle down again, there is no possibility of trading at all."

"I would like 25 good cigars for my husband."

"Yes, madam; how would you like them—strong or—"

"Oh, strong! Very strong! The last he had all broke in his waistcoat pocket."

## Course of Training for Personnel Managers

Columbia University, New York City, has established a course to investigate the complicated problems which personnel managers are called upon to solve. This class, which started February 8, is intended for those who are in the administration end of factory labor departments, for executives who wish to extend their knowledge of methods of meeting employment problems, and for men or women who expect to enter the field of personnel management.

The course will first of all attempt to establish a human point of view toward labor. The personnel manager must first of all shape a definite policy, subject to change if it proves unsatisfactory, toward his employes. His methods of carrying out that policy are a comparatively minor matter. Labor's demands are by no means always a matter of dollars and cents. The demand, for instance, is frequently made for the union shop as a matter of principle, without regard to the wage scale. Should the union shop be recognized? What has happened where it has or has not been recognized? How will it work out in any given industry? For settling practical questions such as these, the personnel manager should first have a "point of view," as the announcement calls it, toward labor. In other words he should have a definite attitude toward his subject based on a clear understanding of his employes both as an organization and as individual human beings.

Industrial relations work, represented by the establishment of clubhouses, benefit associations, athletic fields, has been introduced into many large plants. In some cases the experiments have been failures, in others successful. More frequently the projects have been partly satisfactory and partly objectionable. The original "welfare" idea which started this type of work has been practically done away with. The employes will not stand for anything that sounds like charity, and whatever is done in respect to providing recreation and health facilities for the workers must be offered on the principle that it is a partial wage equivalent and a stimulus to greater production. The concrete experiences of industrial relations work in different plants will be used to show how policies of this nature may be worked out.

Labor turnovers will be discussed, together with methods of record keeping, and analysis of turnover costs. In connection with the selection of employes existing methods and systems will be considered; and the underlying elements of a sound method will be studied. Successful experiments in the manner of selecting new workers who will "make good" have been carried out at various plants, and these will be brought to the attention of students in this class.

Handling grievances is a job that bothers every labor executive and one that has dynamic possibilities for either the good or the evil of the organization. The stories of men who have been able to solve the question of "kicks" and discharges harmoniously will be used to indicate principles which personnel managers may apply in their own factories.

Ordway Tead, a partner in the firm of Valentine, Tead & Gregg, industrial counselors, is the instructor in the course which will meet every Friday evening at Hamilton Hall on the university grounds.

It is poor salesmanship to interrupt a customer, or to show that you are bored.

## Four Passenger Sedan

By Beda Brozik

(Working drawing on page 12)

The design represents a luxurious four-passenger sedan body of absolutely new character. The V front, the square lines of the body, and the unusually finished square mud guards, correspond well together, giving an appearance that is beautiful and strictly out of the ordinary. The body is mounted on the well known Rolls-Royce chassis. The high radiator, the long hood and coil, a result of shortening the body itself, help a great deal in solving the problem of emphasizing the large appearance. Double moldings, forming the belt line are shown running all around the body, which, when finished with cane work, add gracefulness to the job.

The rear seat is well advanced, for the purpose of easy riding, directly over the rear axle. There is no separation or division of any kind between the driver's seat and the rear compartment. The deep upholstery and the roomy interior make this formal car decidedly sociable for the owner who drives. To allow the driver a comfortable entrance the front seat is hinged and collapsible, the same as an ordinary extra seat, but is still very comfortable, as the illustration shows.

The floor in this car has been raised 2 in., making possible, perhaps, a more graceful handling of the body with relation to the wheel housing. The raise brings the floor flush with the sill, making it easier to sweep out. The doors are equipped with concealed hinges and the windows disappear entirely in the sill.

The chassis has a wheelbase of 143½ in.; body space, 105 in.; steering post distance from chassis frame, 21 in.; from dash, 35 in.; wheels, 35 x 5 in.

## Standards of Employment

Major General Harry G. Sharpe has issued a pamphlet entitled "Standards of Employment in War Work," which is now being circulated. The principal recommendations are:

1. A day's work should not exceed the customary hours in the establishment and should not be longer than 10 hours for an adult workman. For women, an effort should be made to restrict the hours to eight. Eight hours should be the limit for a shift.
2. Overtime is tacitly recognized as unnecessary and undesirable and should be discouraged. The employment of women on night shifts should be avoided as a necessary protection.
3. There should always be one day of rest in seven and the half-holiday on Saturday is advantageous throughout the year.
4. An effort should be made to maintain temperature in workrooms and factories as nearly normal as possible.
5. Wages should not be lowered beneath an established standard and should be increased in relation to increases in the cost of living.
6. At least 30 minutes should be allowed for meals and this should be increased to 45 or 60 minutes if the working day exceeds eight hours.
7. No children under 14 should be employed under any conditions and children between 14 and 16 should not be employed more than eight hours a day and night work is prohibited.

FOUR PASSENGER SEDAN  
Description on page 11

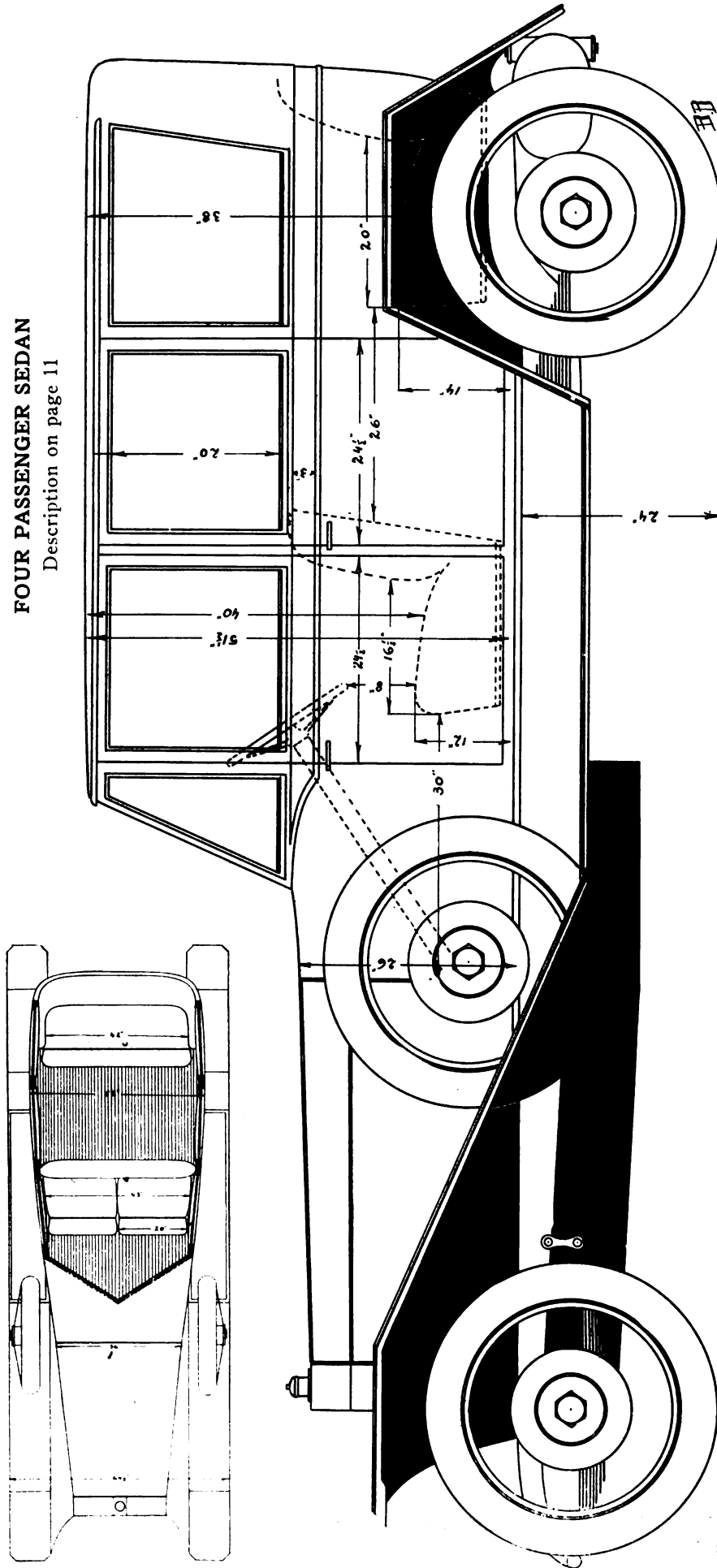

## War Emergency Education in a Wisconsin Motor Plant

By FRANK L. GLYNN,

State Director of Vocational Education, Wisconsin.

The local board of industrial education in the city of Green Bay, Wis., is making a great contribution to the present war emergency situation. The board has solved the problem of training workers for the motor truck industry at a very minimum expense.

The Oneida Motor Truck Co., of Green Bay, Wis., recently obtained a large order for motor trucks from the government for use in the various camps, and work of various kinds at the front. This meant a large expansion in the plant, and a large extension of equipment, also the employment of many persons of whom would be required a great amount of skilled work.

Up to this time this company has had a comparatively small output, doing experimental work in a small factory, turning out sample trucks for the government, and a large amount of commercial orders.

The results of the government order were the immediate purchase of a large tract of land and the erection of the first unit building for the new factory. Other buildings are to be erected very shortly. The occupancy of the new building will require the immediate addition of several hundred trained workmen.

Manufacturing of this type is a new industry in this section of the state of Wisconsin, and comparatively a small degree of skill is found on the part of the workmen, though a large number of people are available for employment. It so happens in the district of Green Bay, as in several other districts, that there are excellent shipping facilities and many natural resources, which are of unusual value compared with many sections of the country. Employment conditions are in a more or less transitory stage, as this and the other districts referred to are gradually turning over from the old lumber days to machine tool building and other manufacturing. In this transition, however, the city has worked out a plan whereby new industries are relieved of the burden of training their help, as this is taken care of by a special type of school training, developed by the state and administered by the cities.

The expense of the instruction by the state as a whole gives the new industries this great advantage.

Here was the situation that the Oneida Motor Truck Co. was facing. They advertised for help and received many applications from workmen, none of whom, however, were of the skilled, or even semi-skilled type, being classed as a whole as laborers. The company estimated that the individual cost would be a minimum of \$60 to \$85 per man, especially considering the possible elimination and turnover of employment, which would amount to considerable.

The situation was investigated by the local industrial education authorities in conjunction with the state system, and a plan finally determined upon, which is receiving considerable attention throughout the industrial interests of the state, especially those which are concerned with the present emergency situation. The problem was to train these laborers so that they would become skilled and semi-skilled workmen in the motor truck industry. The company must also provide an operator for each of the trucks who will be also a truck mechanic as well as an operator.

Upon visiting the new plant it was seen that there were yet about two months remaining before its final occupancy.

Upon visiting the present plant it was found that the business required assemblers, machine operators, general machinists, draftsmen, painters, sheet metal workers, upholsterers, cabinet makers, and general wood workers. The plant operates ten hours a day.

It was also arranged that the company would provide the equipment, heat, light and power, and that the local board of industrial education would take the work over as an evening school, operating it as such from 7:30 to 9:30 or 10 each evening. The foremen of these departments were employed by the educational authorities as teachers and will be paid out of public funds for educational purposes. Applications are being received by the school. Already there are a large number of persons on the waiting list.

The plan of the school organization is such that these applicants are first tried out in the department of the factory in which they would like to be employed. If they are successful in this particular line, then they will continue with their training. If they show, during the evening school period, that they are not adapted to the particular department in which they enrolled, they will be changed from that to another in which success is more assured.

At the present time the company is turning over all applicants for work to the vocational school so that they may enter the evening school training, upon the completion of which the applicant receives a certificate from the school which will provide him with permanent employment in the new factory.

This plan which is being introduced by the state board of vocational education in several cities in Wisconsin, is advantageous to all parties concerned. The average workman in all lines of employment desires to improve himself and obtain a higher wage scale. The only reason for this difference in wage is the "difference in the degree of intelligence." The average workman has no opportunity for improving his intelligence along the line of a new occupation which will bring him a higher income without sacrificing the employment in which he is at present engaged. This motor truck school plant which has been worked out by Green Bay, Wis., will provide so that while the workman is employed in his regular occupation, he has the opportunity afforded him during the evening of acquiring the necessary training for a better position. The result, therefore, is the raising of a number of laborers to semi-skilled mechanics, the semi-skilled to skilled, and providing all with a degree of technical training that is unobtainable otherwise.

On the part of the industries, the men must be trained anyway, even though at an enormous expense and the sacrifice of much valuable material and "spoiled work."

This Green Bay plan takes care of both employer and employe and the city is the beneficiary, not only in increasing the wages of the working people, but also in providing so that help will be trained at a very minimum expense to the public for new industries which require a new type of skill of the people who may be seeking employment along such lines.

The policy is to put the school in the industries at a very minimum cost, rather than to make a large expenditure of public funds for the purpose of putting an industry in a school.—American Industries.

It will take hundreds of dollars invested in honest advertisements to offset the effect of one dishonest one.

### Sporting Type Single Seater

This working drawing taken from The Coach and Motor Builder, of Australia, illustrates what can be done with an old chassis, the chassis to which this body is fitted being a 1912 12-14 F.N. In this model the lubricant and gasoline were in one tank divided off and fitted between back end of bonnet and dash. In drafting, a new tapered bonnet and a new dash is fitted, the bonnet resting on the dash and covering up the tank. A hole is cut through the top of bonnet to fill gasoline tank.

Body is made as follows: Bottom sides got out  $1\frac{1}{2}$  in. thickness outside, outside edge cleaned off to plan. Back ends are halved to back bar, which finishes at rise underneath boot. The body is framed up by making five sections as A, B, C, D, E. Section A is halved into bottom sides at distance back required from column or steering wheel. All these sections are got out and cleaned up to sweep in end view. As the body is curved all through,

Scuttle is framed up in the ordinary way. Scuttle pillar and top rail being framed up in three pieces, and a block fitted in top corner to give round or run down required. Scuttle framing is fastened to dash by three cross bars to strengthen same. Elbow rail runs from top of door pillar to Section A. A round corner is fitted between Section A and top of elbow, and cleaned off to round on body sides.

All being now framed up, body can be paneled up and joints can either be fastened to rail and sections and soldered or riveted and soldered, so doing away with all fastening to woodwork, which always shows in time. No molding is fitted excepting doors.

Mudguards are of the angular type to add to appearance of body. If required, a seat with turnout back can be fitted in boot, there being ample room for same.

A small frameless screen and one-man hood can be fitted, and when body is painted cream, or ivory, the wheels and mudguards dark blue, it looks extremely striking.

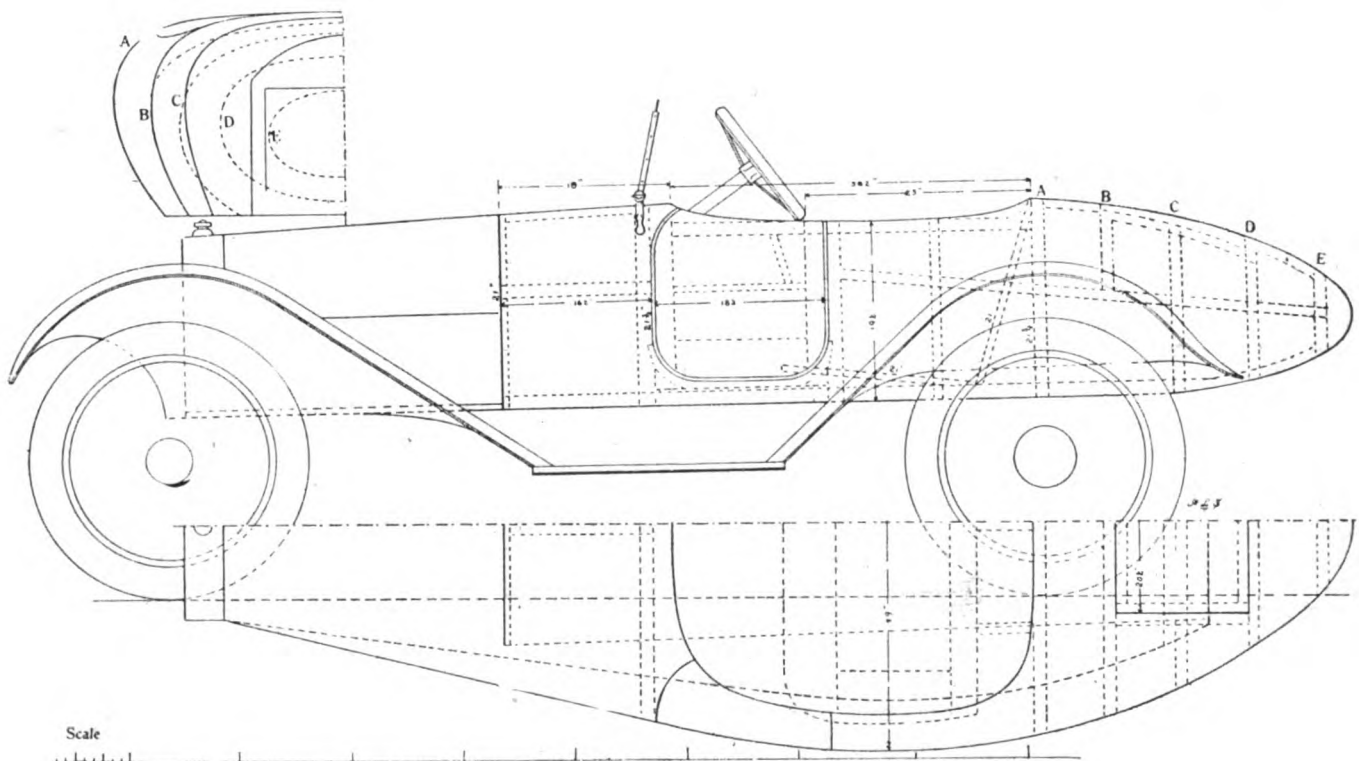

the sections must be in proportion. The best idea is to get them out roughly, roughly fit them all into bottom sides, then clean all off to level required, bending a batten to get correct round. Section A is fitted first, and Section E next. All the other sections are fitted between A and E at equal distances. A side rail is fitted by door pillar to Section E, and is cleaned up to side sweep, this part being the widest through body. Two top rails in addition are fitted on top of boot, being set apart the width of the boot lid required. Also a rail is fitted down center of boot, but this is cut away between B and D for boot lid. Under boot two rails are fitted between back bar and Section E. All joints are halved, and all framing, such as sections, rails, etc.,  $1\frac{1}{2} \times 1\frac{1}{4}$  in. thickness. Three standards are fitted to carry seat back, and are fitted at top to Section A and on bottom to a bar, which runs across bottom sides. The seat itself is framed up in four pieces, and is fitted at back and top of cross bar, and front to heel board, which is made to bind door pillars on bottom.

### New Instrument for Thermal Investigations

In a paper published in a recent number of the *Revue de Metallurgie*, Pierre Chevenard describes a type of differential dilatometer which he has designed for thermal investigations on steels in connection with their heat treatment. He claims that this instrument is highly suitable for use in a steel works laboratory owing to the reliability and simplicity of its design. Only small quantities of metal are required; the instrument is easy to set up, and the readings are not affected by the vibrations which are unavoidable in a steel works laboratory. An instrument of the type referred to has been in use for some time for routine testing in a large steel works in France. It provides a useful complement to the chemical and micrographical examinations of certain steels. Finally, the instrument has proved useful in examining, qualitatively, slight modifications in the dilatibility of metals owing to thermal or chemical influences.



### When the Battery Won't Bat

Have you a battery that will not bat? There is nothing more annoying than to have this important part of the car drop out on the .300 class just when you need it to get back home, says H. Clifford Brokaw, principal West Side Y. M. C. A. Automobile School, New York City. In these days practically every car is equipped with a storage battery, and when it goes wrong everything else about the car is dead also. Since the battery is called upon to supply "juice" for ignition, lights and for the self-starter, the wise owner will learn what to do when the battery fails.

Occasionally on a car using a self-starter system, the battery becomes discharged and has to be removed from the car and recharged from an outside source; or the battery wears out, or a cell becomes cracked so that it will not hold the liquid, or something else occurs, making it necessary to remove the battery for inspection or repairs. When this happens in the city, usually it is possible to procure the loan of another battery from the man who is repairing the one taken off the car.

There are many cases, however, where removing the battery means laying up the car. But this is not at all necessary if the driver knows just what to do upon taking the battery out. It is not safe to simply remove the battery and run the engine on the magneto.

The battery acts as a governor of the output of current from the generator and holds it down to a safe limit. Without the battery it would become excessive and burn out the generator if the engine is driven at any sort of speed. Without the battery the current has no escape, but is confined to the generator, where it keeps building up and gaining strength until the wires in the generator are overheated and the insulation is burned off. If the lights are turned on at this time the current will be so strong that the bulbs will be burned out immediately. Sometimes they burn out from the same cause when a wire drops off the battery, or there is a poor connection between the generator and the battery. The poor connection prevents the battery from taking the full output of the generator and the voltage builds up high enough to burn out the lights.

For this reason it is well to inspect the battery connections often and keep them perfectly clean and free from verdigris. The terminals of the battery are tapered usually and one should be careful to see that they are drawn up very tight, and that they fit, so that contact is made on practically the entire surface. I have seen cases where the connection was so poor the current would only keep one or two lights burning and if the other lights were turned on all would be dim, while if the starter pedal was depressed all the lights would go out. When this condition exists there is danger that when the engine is speeded up the lights will grow excessively bright and then burn out quickly.

If for any reason it is desired to run the car with the storage battery removed, the first thing to do is to lift the brushes so that they do not make contact with the commutator of the generator, or remove them entirely, or leave them in place and connect them together with a heavy piece of wire. Some systems have the generator and starting motor combined in one unit. In this case the generator brushes may be determined by the fact that they are smaller than the motor brushes.

If the engine is provided with a magneto, or a set of

dry cells, the engine may be started now with a crank and will run on this source of ignition current. But care should be taken to disconnect the light wires or refrain from turning on the lighting switch.

If the engine is not equipped with a magneto or a separate dry cell battery, ignition current may be secured by installing a set of six dry cells in place of the storage battery and connecting them directly to the storage battery wires. As the terminals are of such size and shape as not to fit dry cell terminals it will be necessary to make connection between the dry cell terminals and the heavy battery wires with an extra piece of small sized wire.

With dry cells it is possible to operate the lights for a short time, but if you have far to go in the dark you would better use a lantern and drive slow enough to make sure of safety.

It should be understood, also, that the dry cell battery does not act the same in connection with the generator as the storage battery, and it cannot be made a substitute; one should not leave the brushes in the generator and expect the generator to keep the dry cells charged. The action would be the same as though no battery were present. The lights, and very likely the generator, would be burned out.

When installing a dry cell battery in place of the storage battery, the brushes of the generator should not be connected together with wire, but should be lifted or removed, as the wire connecting the brushes will short circuit and discharge the dry cells if no reverse current cut-out is provided in the system. If in doubt, it is best to remove the brushes. There are simpler ways of protecting individual systems and if the driver will take the trouble to learn the peculiarities of the system on his car it may not be necessary to follow these general instructions.

Dry cells are to be had in almost all small towns now, and the owner would be wise to look over the car wiring and generator and see just what he would have to do in case of storage battery failure. Then if he has to make the change in the dark he can go partly by feel, for he may not be able to get a light where it is needed. The car instruction book will give valuable information to the seeker after knowledge, the wiring diagram in particular.

### Marshalltown Buggy Co. to Quit

At the annual meeting of stockholders, held January 21, the former directors of the Marshalltown (Ia.) Buggy Co. were reelected and given authority to sell the buggy company plant and wind up the affairs of the corporation for dissolution as soon as all the assets could be realized upon in cash. The company has been undergoing liquidation for the past 14 months, since L. M. Osborne, the former president and buggy manufacturer, left the company's employ.

The debts of the company have gradually been reduced, and it is hoped can be paid in full during the coming year.

### Fiat Absorbs Three Large Concerns

The Fiat Co., Turin, Italy, which has a capital of 50,000,000 liras, has absorbed the three following companies: The Ferriere Piemontesi Steel and Iron Foundries Rolling Mills, etc., capital 9,000,000 liras; the Officine gia Fili Diatto Railways and Trams Rolling Stock Works, capital 4,000,000 liras; and the Industrie Meallurgiche Torino Steel and Iron Works, with a capital of 4,000,000 liras.

## Examples of Fine Custom Body Work

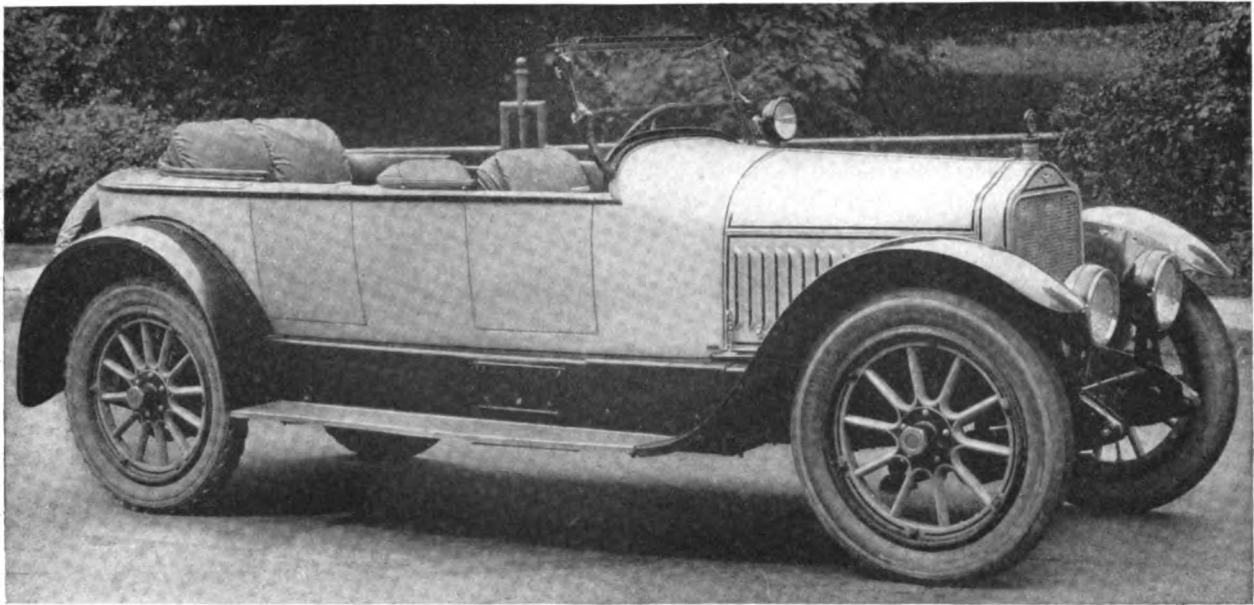

### TOURING CAR

Body by the Rubay Co., Cleveland, O. Mounted on White chassis  
Designed along nautical lines. Exhibited at the New York Salon

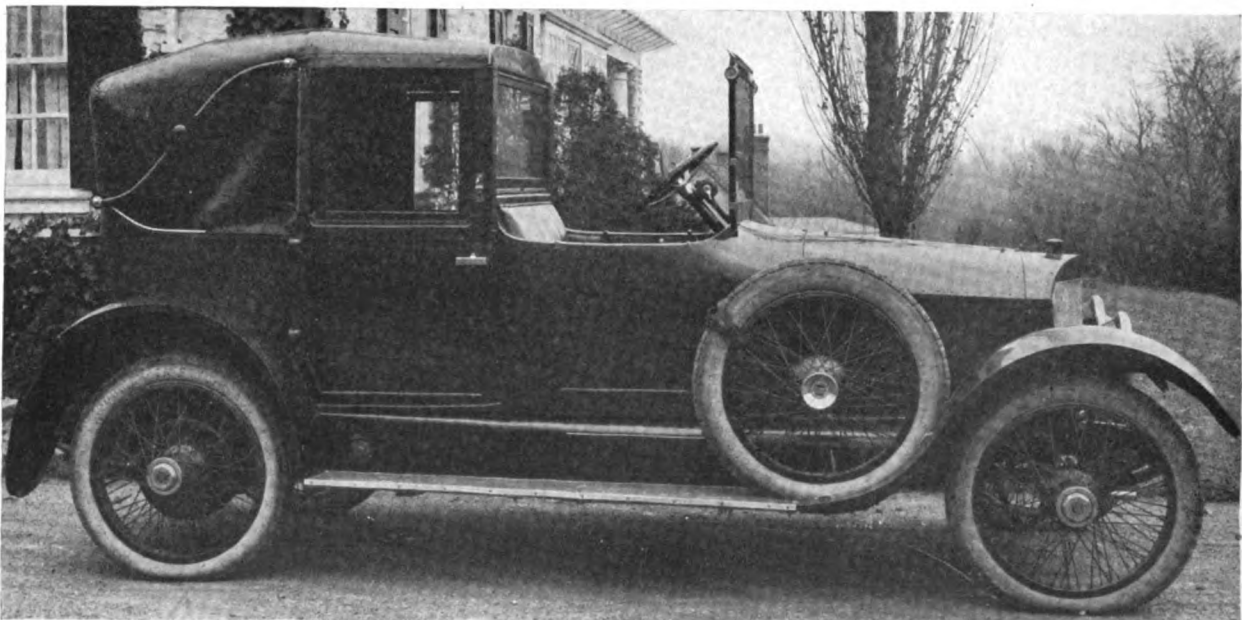

### TOWN CAR

Built by the Biddle Motor Car Co., Philadelphia, Pa.  
Exhibited at the New York Salon

## Exhibited at the New York Salon

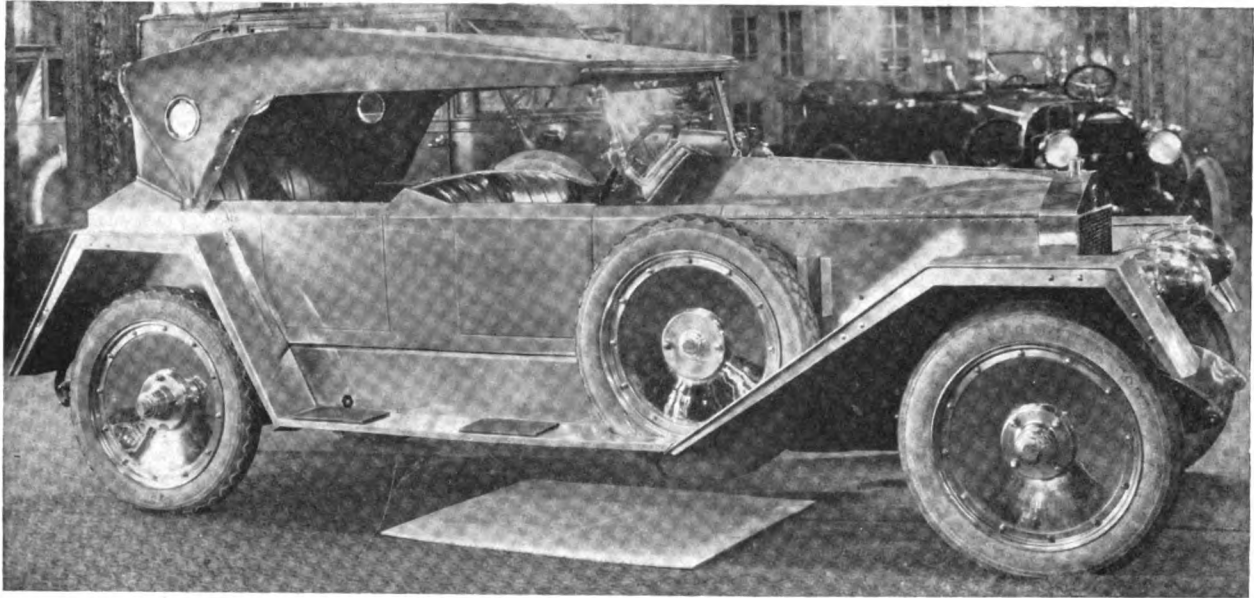

### CUBIST CAR

Built by Murray Motor Car Co., Pittsburgh, Pa.

This car was exhibited at the Salon in New York. The top and blue leather blend nicely with the trimming and aluminum finish. Disc covered wooden wheels.

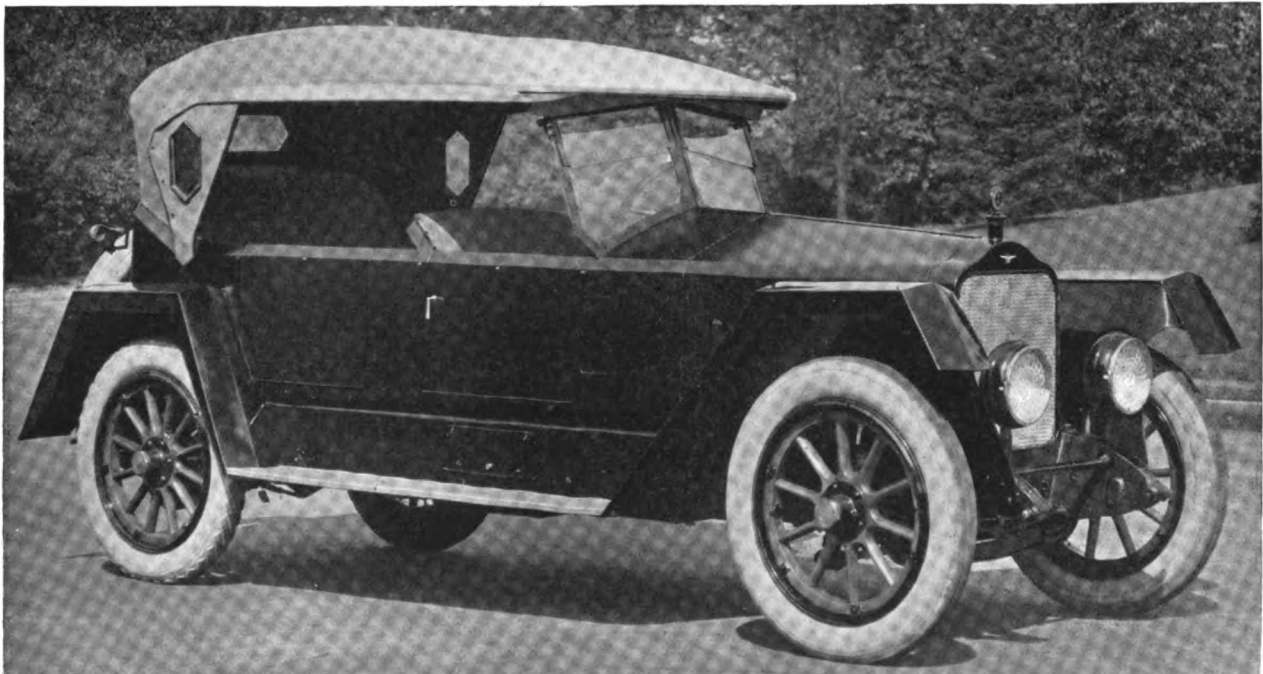

### TOURING CAR

Body by the Rubay Co., Cleveland, O. Mounted on White chassis

Angular effect carried out in body and mud guards. This car was exhibited at the New York Salon

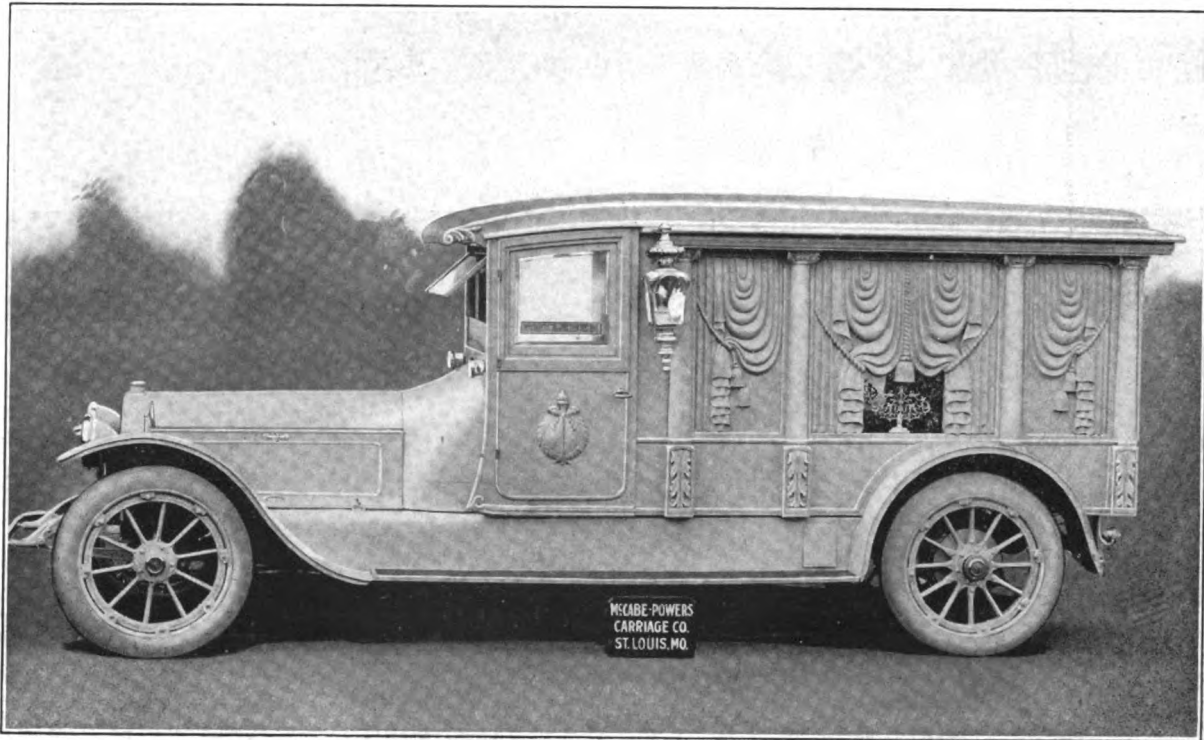

**A FINE FUNERAL CAR OF PLEASING DESIGN**  
Designed and built by McCabe-Powers Carriage Co., St. Louis, Mo.  
Specialists In Funeral Cars and Ambulances

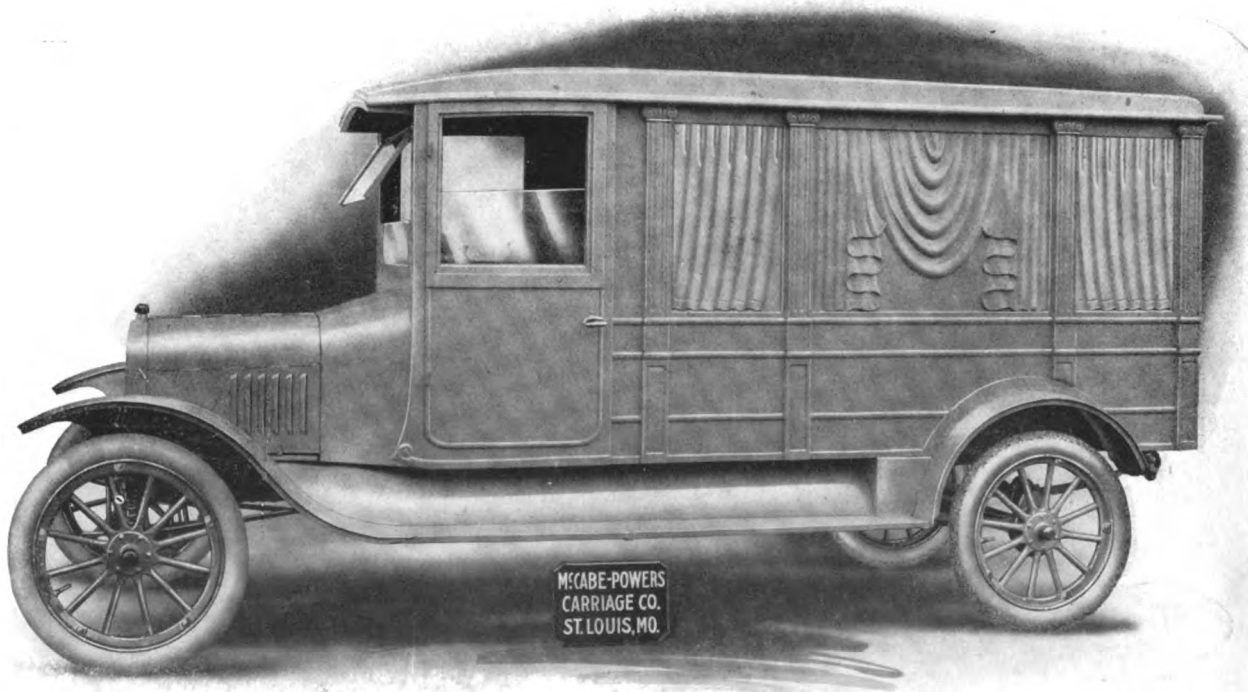

**A FINE FUNERAL CAR**  
Designed and built by McCabe-Powers Carriage Co., St. Louis, Mo.  
Mounted on Ford chassis

# What the Automobile User Is Demanding\*

No one knows better than the automobile manufacturer that the car buyer wants performance. The carbureter manufacturer is familiar with the same thing. He knows that the public is demanding that he produce an instrument which is capable of throttling to speeds hardly in excess of two miles an hour and upon application of the throttle of picking up rapidly and surely to speeds in excess of 50 miles per hour on fuels which are forever going down in quality and volatility. What does the average car user demand? He wants a car that does not cost him too much, in the first place; he wants a car which will be tied up in the service station for the minimum amount of time. It is a matter of pride with every user that his car is dependable, and it is a matter of necessity with most users that the car will be able to perform more than 300 days a year without a falter. If we took an average of all the users in the country, we would probably find that there is a demand for 15 miles to the gallon of gasoline; that there is a demand for quick acceleration, good hill climbing, easy gear shifting, comfort in the seats and springs, accessibility for small adjustments and repairs, a minimum, or rather an absence of rattle, and when it comes to tires, anything short of 8,000 miles is always occasion for a fit of peevishness.

It is a certain fact that the American public demands the appearance of great size in its cars. The largest car selling for a given price will carry large sales, simply due to its size. Coupled with this demand for great size, the American public also demands acceleration. Size means weight and weight certainly operates against the quality of acceleration to such an extent that the torque requirements of the engine must be increased greatly to give the pick-up desired with the large car.

In Europe there are cars which, by a scientific use of the wheelbase, give all the necessary room at a greatly reduced weight, and consequently can supply all the acceleration demand with an engine of greatly decreased developed horsepower. The fact that the car weight is less allows the engine bearings and all other parts to be reduced accordingly and at the same time have factors of safety which are largely those used in average American practice, giving a greater endurance and a smaller service factor than can be expected from the large, heavy, high-powered design which engineers have been forced into much against their will.

## Shorter Car Would Save All Around

This is a time for economy and efficiency; therefore, let us appeal for a car design which is efficient and economical. It is exactly what the public wants, but owing to the education which we have given them through unhappily worded advertisements and by other means, the public believes that its demands are met in proportion with the size of the car. Tire economy and miles per gallon of gasoline and other desirable requirements have been sacrificed because it is believed that acceleration and comfort in riding can only be secured with the car of long wheelbase. As a matter of fact, careful design, coupled

with compactness in engine units, will allow several inches to be taken from the wheelbase of the car without any sacrifice of room, without a great loss in riding comfort, if any loss exists at all, and at the same time with a gain in materials, a saving in weight, a saving in tires, a saving in gasoline, a saving in space required for parking, and a saving in every direction which can be thought of. It costs less to build a shorter car, and this money could be used in refining the design, with the result that probably even greater lightness would result, and better upholstery, better painting, and better trimming could be applied, which would tend to make the result a high class car throughout.

For some reason or other, high priced cars in this country have nearly always been big cars, due to the necessity for catering to the taste for size, and yet the very trend of public demand shows that exactly what it wants can be met in a medium priced small size car which incorporates all the beauty of design to be found in the highest priced products, and all the excellent materials which are used in cars which today are only sold in long wheelbase.

Engine size has nothing to do with performance. Torque-weight ratio is the governing factor in acceleration and hill climbing, the two greatest demands made by car buyers in this country. All the performance desired in a five-passenger car be secured with an engine under 200 cu. in. piston displacement. All the acceleration wanted and all the hill-climbing ability would be incorporated in such a car. The ratio of engine torque to weight could be made very high in such a car at the speed at which such a ratio is most desired, and if an engineer were told to get out a five-passenger car in which all the performance demanded is incorporated, together with an economic use of materials and an economic maintenance factor maintained, he would be wrong to go much above the 200 cu. in. limit. The idea that a perfect riding car is one of infinite weight should not be the goal.

## Weight Too High Per Passenger

Weight of car per pound of passenger weight is too high in America. The tendency toward long wheelbase and big engines is responsible. A five-passenger car should not weigh more than three pounds per pound of passenger weight if it is to be considered a truly economical design. With a designed load of 750 lbs., a 2,250-lb. car would be about right.

If this economy in material and maintenance were carried out there would be much less talk regarding material shortages, and this vital means of transportation would not be threatened to be put in the class of non-essential industries.

This presents the picture from one side. We all know what the public demands because we know exactly what we like ourselves in a car. We like to step into a roomy, comfortable front compartment, into which we do not have to squeeze in order to seat ourselves behind the steering wheel. We are always pleased when our first glance tells us that the control members can be readily seen and readily reached. We want the engine to start

\* Extract of paper by J. Edward Schlipper, before the Cleveland Section, S. A. E.



almost on the first touch of the starting button; we like the starting pedal to engage with little effort, with the engine running smoothly and quietly; we want a clutch pedal which is depressed by very light touch of the foot and which when engaging gives a smooth pick-up without unnecessary slipping and without excessive grabbing. In shifting gears the clutch should release instantaneously and positively, so that there is no drag in the gears, and the gear lever itself should throw into mesh with a minimum movement and with a minimum amount of reach required to place the hand upon the shifter cane. In picking up, the operator should be able to depress the throttle almost as quickly as possible without creating undesirable conditions of knocking, choking, spitting back, or laboring of the engine. In other words, carburetion, gear reduction and engine capacity and torque output should be so attuned that a smooth acceleration ability is given. Here, of course, lightness again enters.

#### **Starting Rapidly Most Pertinent Point**

Winter is now upon us, and to the list of requirements given above must be added that of starting rapidly on a cold morning. This is the most pertinent point of all at the present time.

All the hot spot intakes and exhaust jacketed carbureters in the world will not do one thing toward making the car easier to start. The carbureter manufacturers have provided us with very efficient chokes; even at the speed attained by the average starting motor on a cold morning these chokes are capable of shooting into the cylinders a supply of raw gasoline which would go a long ways in operating a dry cleaning establishment. Sometimes some of this raw liquid is ignited during the first three or four minutes of cranking, but quite often the motorist helps the situation along by distributing  $\frac{1}{2}$  pint more of gasoline between the four, six, eight or twelve cylinders. This joins the supply which the efficient choke has put into the combustible space, and ignition starts only, however, after a liberal supply of the raw fuel has leaked its way past the piston rings and gone down into the crankcase to help form what is sometimes called "crankcase soup."

If the car starts in 30 seconds the user is fairly well satisfied. He does not think, however, of all the gasoline that can be drawn into the cylinders and leak past the piston rings in the space of 30 seconds, he does not consider the fact that his lubricating film has been destroyed to a large extent by this gasoline, and he does not stop to consider how much the supply of lubricant in the crankcase has been deteriorated due to dilution of the oil by the heavier constituents of the gasoline.

This situation is probably the most serious one which confronts the designer today. The automobile user is demanding service, and he will not get good service from an engine which is being treated in this manner. The first few minutes of running with an engine in this condition are working considerable damage to that power plant, and the problem must be met quickly or else a great amount of damage is going to be done during this winter to cars which are kept in unheated garages.

Something must be done to meet the cold starting situation. A heating coil in the float chamber, or some other gasoline chamber, a water heating system connected with the radiator, or some other method which is equally effective, must protect the owner from the consequences of crankcase dilution. The average owner is wise enough to know that it is requiring a pint or more of gasoline

for him to get his engine warmed up on a cold morning. He knows that he is not burning this pint of gasoline and all of it is not going out of the exhaust; therefore, the remainder forces its way into the crankcase, and cars which are fitted to combat this trouble are going to have a strong selling argument and are going to go a long ways toward meeting one of the biggest demands made by car users on the car manufacturer.

#### **Preheating the Air**

The heated intake has been studied so carefully by all manufacturers that it is useless to dwell upon it. Only one suggestion should be made, and that is that there are a great many manifolds which are erring on the side of too much heat rather than too little. It is practically impossible to meet the extreme ranges of temperature conditions, which range amounts to 100 degrees or more in most of the cities along our temperate belt, without some sort of adjustment. The air is always preheated to some extent and probably the means of adjustment to meet the outside temperature conditions is most rapidly effected by varying the amount of heat which is imparted to the initial air before it enters the carbureter. Too much heat makes the engine unsatisfactory, due, of course, to its reduction in volumetric efficiency, but the proper amount of heat, in spite of the expansion of the intake gases, will often result in an improved torque curve.

It is a noticeable fact that this year's car users are demanding gasoline economy more than ever, and vigorous activities can be noted on the part of carbureter manufacturers to supply this demand. The carbureter, however, is not the only factor in economy. Lightness, which has always been important from a performance standpoint as well as that of economy, is a paramount necessity. Lightness does not only mean the reduction of weight by scientific design of parts, but it is possible to gain a far greater amount of weight by a scientific use of wheelbase length. In this country we have been wasteful of wheelbase. We have secured a minimum of passenger space with a maximum length of car. It has been possible in Europe, due to the use of shorter engines, shorter hoods and the more scientific location of parts, to get much more room on a given length of car, with the result that the car weight per passenger has been very much reduced. Scientific designing from one end to the other would make possible a great economy in materials and yet a very little sacrifice in performance; in fact, there need be no sacrifice but an actual gain in the way the car operates.

The rear axle gears and in fact the entire transmission mechanism should be quiet and sturdy, the propeller shaft should not whip, and none of the parts beneath the chassis should be so filled with grease cups that the user of the car is fortunate, indeed, if he finds 25 per cent of them on his first greasy search beneath the chassis.

#### **Imitation Leathers Rendering Excellent Service**

The appearance of the car should please the eye. Exterior appearance is a matter of choice, and like a great many things which are changed from season to season, it is impossible to lay down any rule as to what they should be like. Present-day style calls for long, straight lines without sharp breaks from radiator cap to the end of the tonneau. Another year this might be different. Nevertheless, the car should conform to the dictates of the moment. The upholstery should be good, and here it may be said that some of the latest of imitation leathers

are rendering excellent service and are doing better in fact than poorer grades of genuine leather.

The top should be so designed that it is quickly put in place, and the side curtains should permit of ready view on all sides of the car. Some of the side curtains, with their small lights, shutting off the view of the driver, are a positive menace in city driving rather than an advantage. The windshield should be drip-proof and have the ventilating feature which has come to be demanded by everyone. The public is demanding a good car and an economical car, and the engineer must supply by scientific design what the public demands in the face of the fact that he is now under limitations of material which did not hinder him a year ago.

### Women Make Fine Auto Factory Workers

"After watching for years automobiles being driven more and more by women, we must now contemplate, with the best grace we may, the spectacle of women invading the field of automobile manufacturing," says Du Bois Young, vice-president and works manager, Hupp Motor Car Corp.

"The Hupmobile factory is probably employing fewer women than many other automobile factories of its size, but we were one of the first to employ this class of labor, and we believe that we have experimented with women in more departments than have most other manufacturers.

"For years women have been employed in our top and upholstery departments; this is common practice in the industry. But the war and the consequent shortage of labor, both skilled and unskilled, made it necessary to look upon women workers as our surest source of relief.

"Our first experiment with women in the new field was in the parts division of our service department. Here they were employed as stock checkers and stock order fillers. We were agreeably surprised to find that women at this work were more efficient than the men previously employed.

#### Better Than Men at the Work

"The women doing this work are more intelligent than the corresponding class of men. They are also more interested in their jobs and more careful by nature. The same spirit that insists that parts in a stockroom be kept in their proper bins insists that pots and pans be kept in their proper places in the kitchen. Errors in the filling of parts orders and mistakes in inventory due to careless storage have been reduced enormously since the taking over of this work by women.

"Light assembly work on the car itself was the next work assigned to women. Certain operations in connection with the assembly of running boards and other light installations were well within a woman's strength and required no particular mechanical training. On this class of work, too, women surprised us by their accuracy and industry. Final inspection shows less to criticize in the assemblies now handled by women than when they were handled by men exclusively.

"In the service repair shop women were set to work disassembling jobs sent in for repair and jobs turned in for salvage. Neatness and thoroughness characterized their work in this department, and I believe the workmen would object to a return to the old order.

"Women have not yet invaded our machine shop, but if industrial conditions continue to develop along present lines certain machine shop operations will be in women's

hands before many months. Wherever an operation is handled by an automatic machine oftentimes a woman can take the place of a man. This is not always true, for where one man on account of his training can take care of several machines, two women would be required to do the same work.

#### Can Do Heavy Lifting

"In emergencies that have arisen in the departments where we are now employing women, we have seen evidences that women are capable of doing much heavier work than is commonly considered within their powers. We have men, of course, to do the heavier lifting, but many of the women in their enthusiasm do not wait for the men to do this kind of work, but do it themselves, apparently with considerable ease.

"Those who maintain that the physical standards of women are degenerating in these modern days should spend some time in the Hupmobile factories watching the women workers. They are a strong, husky, wholesome lot, much healthier in every way than the men they have replaced. Absences and tardiness due to ill health have been reduced to a minimum since women have been employed. This is due partly to the fact that women are intensely interested in this new work and anxious to make good, and partly to the fact that, being more regular in their habits than their predecessors, they are less susceptible to colds and other diseases.

"What will happen after the war, when men return from the front or from other occupations into which they have been drawn by the war to find women holding their jobs is worth more than a passing thought. An industrial revolution is predicted by some, but this seems an extreme view to take of the situation. In the first place, the women who are now filling the ranks are the wives, sisters and daughters of the men they are replacing. An industrial revolution based on this substitution would quickly be turned into a domestic revolution with the odds all on the side of the women.

#### Would Make Men Do Better

"Second, not for a great many years to come will women in the industrial field seriously contend with the skilled workman. Although in many ways they are his superior, they have not the inherited aptitude and mechanical ingenuity that are his. In tasks assigned to them they are more painstaking and conscientious than he, but they have not at present the self-reliance and inventive genius which enable the American workman to become a skilled mechanic.

"My prediction is that the after-the war labor problem as far as women workers are concerned will be solved by compromise. A certain rather careless type of workman will find jobs upon which he used to depend filled permanently by women. In self-preservation he will have to become a better, a more skilled workman. In the end the tone of the industrial ranks will be perceptibly raised, with lasting benefit to the workers and their employers."

### Trus-Con Paints for Automobiles

The Trus-Con Laboratories, Detroit, which for the last eight years has specialized in the manufacture of technical paints and varnishes, will manufacture paints, colors, color varnishes, clear varnishes and baking japans for automobiles, trucks, tractors and machinery. R. Alfred Plumb has organized the new department.

## Warring Nations Favor Metal Wheels

Wood wheels of all kinds have given such a poor account of themselves under war conditions that it is safe to assume they will cease to exist within a few years. Already wood has been eliminated from wheel construction of about 90 per cent of European motor vehicles. It does not always follow that a design or type of construction which has proved superior under war conditions will be best for peace conditions; but in this case the types of wheel which have proved superior in war undoubtedly will be retained after the war.

There are three main types of metal wheel in use at the present time: the wire spoke, the pressed steel, which may be either of the disc or spoke variety, and the cast steel wheel. For heavy loads—above two tons—the cast steel wheel is the only type used by European makers. There are practically no trucks of three, four or five tons capacity now built in England, France or Italy with wood wheels. Italian and French makers prefer the cast steel type. English manufacturers are rather divided between the cast and the disc types. The Fiat Co., which is the largest motor concern in Italy, decided on metal wheels as far back as 1903, and has adopted cast steel to the total exclusion of wood; in fact, this company never has built a commercial car with wood wheels.

There are two types in service, the hollow spoke wheel, which is a rather difficult foundry proposition, and the cast wheel with a transverse section in the spokes in the form of a cross. The advantages claimed of cast steel over wood are: Greater strength, immunity from climatic conditions, longer life, a slightly lower cost of production, a moderate saving in weight, and (this matter is of importance in the war zone) a greater factor of safety when under fire. Shell splinters which would seriously damage a wood wheel do little harm to a cast steel wheel. In case of a truck catching fire, wood wheels are certain to be destroyed, while cast steel wheels are practically unaffected.

A type of wheel which has been very much developed on the Continent since the war is the steel disc. It consists of the usual rim and a steel disc of uniform thickness stamped to the correct shape. The disc is forced into the rim and both electrically welded and cold riveted to this latter. Finally, two steel discs are riveted to the central portion of the wheel, and these three thicknesses of metal are drilled to receive the five, six or ten studs by which the wheel is held in position.

This type of wheel is used on the one ton and 1½ ton trucks with dual pneumatic tires. Practically the entire Italian aviation service and a very considerable portion of the French aviation and ambulance services are equipped with the type of disc wheel. An attempt is being made to popularize the wheel for heavy touring cars requiring dual tires on the rear. As at present made, a set of steel disc wheels—single tires in front, duals in the rear—is rather heavier than a set of wood wheels with detachable rims. Also the fact that a complete wheel is carried as a reserve increases the total weight compared with wood wheels and detachable rims.

While it is predicted that the wood wheel is destined to disappear from ordinary touring cars, it is doubtful if it will be replaced by any one type. The Fiat Co., which is the only firm in the world using metal wheels throughout its series, from the smallest two-seater to the heaviest

tractor, has for a long time employed detachable steel wheels for its ordinary touring models. This is a pressed steel type, but of the spoke variety, stamped in two halves and welded together. Naturally it is of the detachable type, has all the appearances of a wood wheel, but none of its disadvantages.

Up to the present, American makers have remained aloof from the metal wheel development. This is explained by the fact that the United States had a very good supply of second-growth hickory, and that wood wheels have been of better quality than those made in Europe. American military authorities are said to be impressed by the excellent results obtained by all types of metal wheels in Europe and are disposed to favor similar types for their army vehicles.

## Care of Tires in Storage

Suggestions for proper preparation of tire and tubes which are to be stored during the winter months are made by Frank C. Millhoff, general sales manager of the Miller Rubber Co., Akron, O. "Those who do store their cars should take at least one precaution," says Mr. Millhoff, "and that is remove each tire.

"Next I would cleanse the outside of the casings with ordinary soap and water. The object in this is to remove all traces of oil which, as is well known, operates detrimentally to the life of the tire. Then I would examine both the inside and the outside for bruises or injuries; make what repairs are needed and finally wrap the tire carefully in a clean cloth—or preferably black paper—and lay it flat in a cool, dark room. The inner tube should not be neglected. A leaky, faulty tube simply shortens the life of the tire by thousands of miles.

"I would not allow a tube to remain in the casing, no matter how good or how poor it was. I would carefully clean off each one, then lay it flat in a cool, dark place as in the case of the tires. A cool, dark place is recommended because the actinic rays of light are injurious to rubber.

"If I did not want to remove the tires, the very least I should do would be to jack up the car enough to take the weight off the tires and leave just enough air in them to keep them tight and in shape. The spirit of conservation calls for simple precautions as these, but from another standpoint—they are necessary if the motorist is to get out of his tires all that he can reasonably expect."

## 469,135 Ford Cars Produced in Six Months

The output of the Ford Motor Co. for the past six months was 469,135 cars, or at the rate of 938,270 per year. During the month of October there were 79,675 cars manufactured. The estimated production for this year was placed at 900,000, or about 3,000 per day, but unless war conditions prevent there is little doubt that there will be more than 1,000,000 cars manufactured.

## Detroit Has 118,489 Employes in Auto Industry

According to the report by the Michigan Labor Commission, the automobile industry employs practically 50 per cent of the industrial employes in the six largest Michigan cities. Detroit alone employs 118,489; Flint, 18,262; Lansing, 7,875; Jackson, 4,683; Muskegon, 2,847; Pontiac, 5,747.

## Technical Training in Automobile Shops

The development of an educational adjunct to provide technically trained men for service positions is a new and exceedingly interesting phase of the automobile industry. Among the manufacturers who have taken hold of the situation with a vigorous policy is the Packard Motor Car Co., which has just opened a new technical service school in its big Detroit plant. The plan of its operation allows remuneration to all students enrolled while they are mastering motor mechanism and service, and allows for increases in the earnings based upon the student's usefulness to the company while learning, his previous application to similar problems, his previous experience in mechanics and his previous technical education and training.

This school, established for the improvement of technical automobile service, is divided into three parts:

to the production of motor vehicles. Men turning a piece of steel under the ponderous hammers striking tons and tons at a blow, men guiding cutting tools on a product that must check up to within one-ten-thousandth of an inch, demonstrate the wide range of human skill that must be employed in the production of a coach that today all the world will ride in and look with disdain on Cinderella's gorgeous outfit.

To work and study at the same time in the presence of so wondrous a mechanical laboratory as the Packard factories is a privilege of the age. Such students not only have these highly specialized machines and operations before their eyes, but they have the machines and tools in their hands. Here, it appears, the everyday mechanic who comes up from the service shops for specialized instruction realizes that he has some very decided advantages. For despite the liberal, specialized equipment of regularly

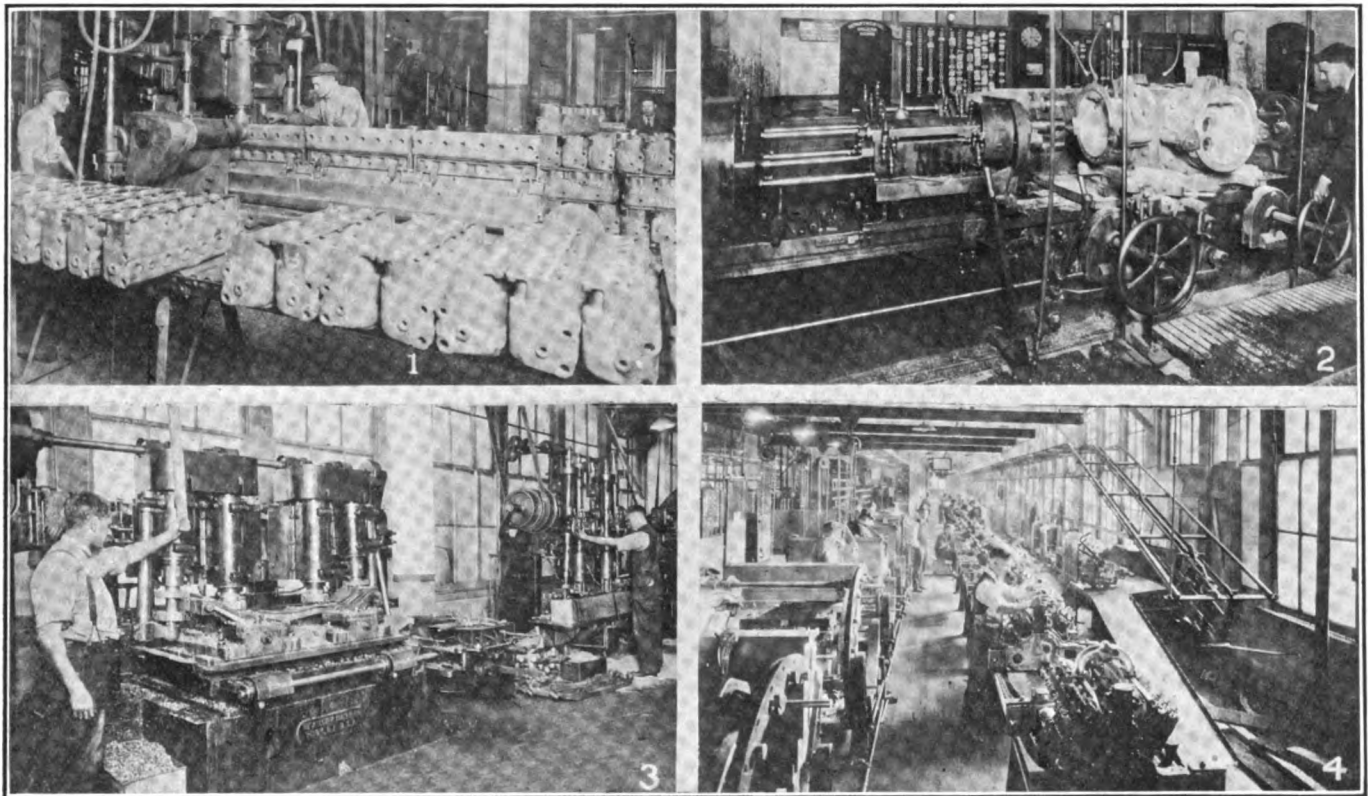

Key to Illustrations of technical training on important Packard twin-six machining operations: 1, Milling the cylinder blocks before they start on their journey to the assembly department; 2, Milling four clutch housings at one time; 3, Front axle under battery of end mills and drills; 4, Assembly and adjusting motors

1. Mechanical training and underlying principles.
2. Mental training that gives independence of thought in solving service problems.
3. General training in business to give better perspective to an employee.

To witness the mechanical operations in an automobile factory is almost a marvel to the uninitiated. They are a succession of applications to metals of the genius of the ages that weave a spell of fascination to the human mind. To see the raw material fabricated is almost as if one were standing on the threshold of Cinderella's house and observing the fairy godmother fashion the child's golden coach and liveried lackeys out of the base pumpkin of the story book. Modern industry and the automobile section in particular performs this mystic feat hour by hour and minute by minute in the great shops that are devoted

organized scientific schools, the ordinary technical student from a scientific school would be overjoyed if he could but get his mastery of shop operations in a commercially producing shop, and leave out the matter of getting paid for his time as regularly as the week rolls around.

The student who intends to be fitted to be a technical man is fitting himself to assume the responsibility of policy and conduct of the service office force, the handling of service customers, garage, inspection room, repair room, machine shop, forge and welding shop, paint and varnish shop, accessory repair room, upholstery and body shops, stock room, storage place or such other divisions as may be incorporated in the service establishment. To do this he becomes acquainted in a three months' course in brief but careful study on the following schedule:

Four weeks each in the car factory and the truck fac-

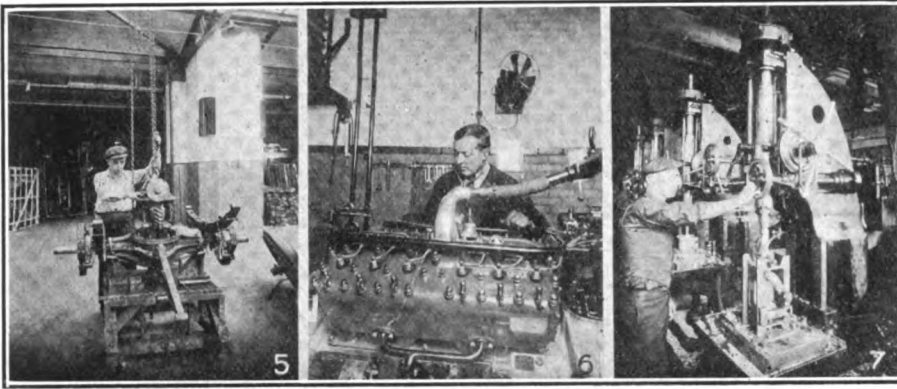

Miscellaneous operations: 5, Assembling differential of rear truck axle; 6, Identifying motor sounds detected by the aid of a stethoscope; 7, Drilling a steering knuckle

tory on the following subjects: Motor assembly, carbureter and clutch, transmission and axles, steering, chassis assembly, final repairs and tuning, motor repairs.

Two weeks in the main factory on the carbureter, electrical system and small parts.

Three weeks in the operating department on inspection of cars and trucks and testing cars and trucks.

A carefully worked out system, alternating shop work and class instruction makes this vocational education undertaken in an automobile factory in many respects unique. Never losing sight of the ultimate value to the motorist of the specialized skill and knowledge which is being prepared for the field, the combination of practical experience on the drill press, lathe and assembly platforms with lectures and class room instruction is constantly maintained. Without stopping for dress formalities, the learners pass directly from the machines to the blackboard and a seat in the class room for the mental drill, which fixes their manually gained knowledge of a few moments before and the increment of the same to be obtained the moment they pass out of the class room into the shop again.

The wealth of mechanical facts which are presented to the view and reach of the student learner and from which it is possible to equip himself with stores of useful, practical information, is inestimable. He is in close touch with it all, as participant and observer. He may go with the cylinder blocks of the twin-six engine on their first visit to the machine shop, where they receive the necessary machining and the main parts of the engines take on their refined form and finish before starting on their journey to the assembly department. He tarries at the station of the intricate and ingenious machines that make inaccuracies

almost impossible in the drilling of the clutch housing.

He makes a detour, perhaps, and hangs over the multiple drills working on a clutch housing, where dozens of drills on one machine accomplish in a few minutes what used to take hours, demonstrating how man's effort is multiplied many fold by this machine. Or he is at another time at the station of the battery of end millers where the front axle takes on its final contour and passes on to a press, where all the necessary holes are drilled at one time.

In due time he is sure to be on the progressive assembly platform, where the crew of workmen is putting up and adjusting the twin-six power plant. Here, starting with the cylinder blocks and base, the engine rolls along between rows of men until it passes off at the far end of the room ready for installation on the chassis. From these operations are obtained fine points of motor adjustment.

Without attempting to follow all his opportunities and successive stations, it is, nevertheless, valuable to go with him to his points of contact in several other places where skill is imparted to the hand and facts impressed indelibly on his mind for future usefulness. There is, for instance, the period of association and working with the engine doctor or inspector who diagnoses all the troubles in the twin-six engine with a stethoscope. The training of the ear to identify motor sounds is a point of no small importance. In the factory this inspector detects any little sounds that indicate that all is not going according to specifications. He seldom locates any defects, but looks over every engine before it passes along, as all Packard power plants must be perfectly healthy before they are sent out into motordom. At other points in the operating department inspecting points are obtained and illustration 8 shows how some of the reading is done. While the boring machines work with great accuracy, delicate gauges and instruments are used in checking up the work. Inside surfaces of cylinders must check up to within one-tenthousandth of an inch.

#### Following the Truck Units

Access currently to the truck factory stimulates and rounds out the technical training of the Packard students on the side of future work on commercial cars. In the mechanical department he may be engaged in the maze of



Key to illustrations: 8, Working with multiple drills on a clutch housing; 9, Inspection of twin-six cylinder after boring, with gauge checking to a thousandth of an inch; 10, Stockkeeping where there are thousands of bins numbered and contents catalogued





Key to illustrations of technical training in the truck department: 11, Machining operations on motor truck crank cases; 12, Motor adjustment on the conveyor where motors are assembled; 13, Where truck chassis are assembled and the practical points of truck chassis work are obtained

drill presses boring a hole in a truck steering knuckle as against the time of need out in service work when accidents anywhere bring the knowledge of such operations into play. Or he is down where the crank case of the truck motor is fed up to the milling machines on rollers, where men no longer needlessly waste energy in carrying about heavy parts, for, when finished, the cases are lifted from the machine beds by pneumatic hoists and are transported to the station of the next operation by overhead tracks.

And then there are the days spent with the truck engine, which, fastened to fixtures, rolls along a track in the process of assembly and adjustment until it is completed, where the student is learning the methods and fine points of adjustment. Long rows of men attend the engine on its journey, putting its parts in place, and each man, by specializing in his one duty, works with great dispatch and accuracy. Then on into the big truck assembly room, where the various units are put together, and through the inspection processes which finally allow the finished truck to go out into service on its next and last move.

Short courses of three and six months imply a considerable ground work of mechanical experience or business supervision previous to their taking up. So there is provided the one year course, where time for shop work classes, lectures and examinations is multiplied until the ground work is prepared with special care, and the following schedule of it gives an excellent idea of the scope of instruction and the wealth of opportunity:

General machine shop, nine weeks—Drill press, milling machine, engine lathe, bench work.

Assembly and parts repair department, ten weeks—Steering axles, clutch, transmission, carbureter, cylinder and pistons, small parts.

Sheet metal, one week—Radiators, fenders.

Truck factory, seven weeks—Motor assembly, block test, dynamometer.

Car factory, 12 weeks—Clutch and transmission, steering, chassis assembly, final repair and tuning, carbureter.

Main factory, three weeks—Electrical, small parts, carbureter.

Service department, six weeks—Motors, repairs, cars; repairs, trucks; electrical.

Operating department, four weeks—Inspection cars and trucks, testing cars and trucks.

Besides the technical training obtained in shop experience, other time and study gives insight to the general conduct of a service station. Students are given a per-

spective on the relation of service to other departments of the dealer's business. Greater business capacity, executive ability and independence in solving all service station problems is the prime purpose of the course. In connection with detailed study of service principles there is the immense stock room where there are thousands of bins, each one numbered and so catalogued that attendants can procure any bolt, nut or part at a moment's notice and with practically no likelihood of making a mistake. The elements of systematic stock keeping inculcated here are without doubt of inestimable value. The stock depot side of the service problem has its special six months' course of training.

It is not without significance that the earlier years of the automobile industry was turned to perfection of product. It is equally inevitable that an era should come when the industry must turn its attention to the perfection of the service that a highly perfected product must entail. So it is not really surprising that the time has come to recognize the shortage of technical skill and take such steps to meet it: as in this system the Packard company is developing. Every man accepted for the school makes contractual relations to insure that he applies his skill to the organization that polished up his earning powers for a period which will reimburse it for the outlay made. The school is open to all men who have had automobile experience and when a student has finished his course a position is found for him in a Packard service station or at the main factory, where he receives the prevailing scale of wages. Much of the work done by the student partakes so largely of the experimental nature that it cannot be regarded as productive and is not permitted to go into the construction of the actually marketable product.

The instruction thus afforded in distinctive automobile avocations well nigh strikes a collegiate level. To the motorist it promises adequate, high grade service.

### Layout Work

To whiten a surface for laying out work, mix whiting with gasoline to the consistency of thin paint and cover the work to be marked. The gasoline will soon evaporate, leaving a white surface on which lines can be easily scribed.

### To Harden Reamers

To harden reamers heat slowly and evenly to a bright cherry red. Quench quickly and immediately immerse in a bath of linseed oil, holding reamers vertically, and draw the temper to a straw color, as for a tap or a die.

## Unfair Competition Charged in Paint and Varnish Industries

The Federal Trade Commission on February 25 authorized the issuance of complaints charging 38 concerns with various unfair methods of competition in violation of Section 5 of the Federal Trade Commission Act. This is the largest number of complaints ever acted on at one time. The complaints allege that respondent concerns stifle and suppress competition through lavish entertainment of competitors' employes, secret payment of money to employes of customers who might otherwise buy goods from competing concerns, and in one instance the respondent is charged with the adulteration of competitors' goods.

The Glidden Varnish Co., of Cleveland, O., is charged with attempting to stifle and suppress competition by "systemically and on a large scale" giving employes of customers, prospective customers and competitors' customers, gratuities such as liquor, cigars, meals, theatre tickets, valuable presents and entertainment. It is charged also with "secretly paying" employes of its customers, prospective customers and competitors' customers large sums of money as an inducement to influence said employes to purchase from the Glidden Varnish Co. varnish and kindred products, or to influence such customers to refrain from dealing with competitors of the respondent. Practically identical complaints were issued simultaneously against the Columbus (O.) Varnish Co.; Flood & Conklin Co., Newark, N. J.; Walter L. Trainer Co., Philadelphia; N. Z. Graves Corp., Philadelphia; Van Camp Varnish Co., Cleveland; Sun Varnish Co., Louisville; Lilly Varnish Co., Indianapolis; McCloskey Varnish Co., Philadelphia; Lindeman Wood Finishing Co., Shelbyville, Ind.; Adams & Elting Co., Chicago; Valentine & Co., New York City; Bridgeport Wood Finishing Co., New Milford, Conn.; George D. Wetherill & Co., Inc., Philadelphia; Reliance Varnish Works, Newark, N. J.; Blackburn Varnish Co., Cincinnati; Frank W. Thurston Varnish Co., Chicago; Grand Rapids (Mich.) Varnish Co.; National Varnish Co., Long Island City; Standard Varnish Works, New York City; Mayer & Loewenstein, New York City; Boston (Mass.) Varnish Co.; Louisville (Ky.) Varnish Co.; Murphy Varnish Co., Newark, N. J.; Marietta (O.) Paint & Color Co.; O'Neil Oil & Paint Co., Milwaukee, Wis.; Grand Rapids (Mich.) Wood Finishing Co.; Forbes Varnish Co., Cleveland; Lawrence-McFadden Co., Philadelphia; Pratt & Lambert, Inc., Buffalo; Rockford (Ill.) Varnish Co.; Chas. R. Long, Jr., Louisville; Ault & Wiborg Co., Cincinnati.

Included among the complaints issued is one against the Essex Varnish Co., of Newark, N. J., which contains allegations similar to those made against the firms mentioned above, and in addition includes an allegation that the Essex Varnish Co. has secretly paid employes of its customers, prospective customers and competitors' customers "large sums of money to adulterate and spoil for their proper uses, varnish, lacquers and japans sold or offered for sale by its competitors to such customers."

The firms named in the complaints are given the usual 30 days to reply and have been notified that the commission will hold a hearing on all complaints in question on the morning of April 8 next. The complaints issued are the first results of a long and intensive investigation by the commission. In the course of this investigation attorneys and examiners for the commission discovered what

it believes to be a very serious and unhealthy condition to exist in certain lines of industry. The commission has under consideration, as a result of its investigation, a large number of similar cases requiring further deliberation.

In a few instances the commission has, at the request of certain concerns, arranged for consent orders against those who, having used these methods, have desired to avoid publicity in having their affairs investigated.

## Motor Cars Slow to Follow Price-Increase Trend

One way in which motor cars have been slow is in following the world-wide price-increase movement in nearly all lines during the past three years. This fact has been developed in a surprising way by a comparative analysis of price fluctuations of automobiles and leading commodities just made by the National Automobile Chamber of Commerce, as shown in the accompanying table. The average wholesale price of all the automobiles and motor trucks produced in the United States during the last six years shows a decrease each year ranging from 4.7 per cent to 16.5 per cent until last year, when there was an increase of 4 per cent. Prices of 13 principal commodities, as reported by Bradstreet's index, decreased slightly until 1915. In that year they increased 18 per cent; in 1916 more than 28 per cent, and last year more than 30 per cent. English commodity prices have increased 87.5 per cent since 1913.

	Motor Vehicles Average Wholesale Prices		Bradstreet's Commodity Index		London Economist Commodities Index	
		Per cent increase or decrease		Per cent increase or decrease		Per cent increase or decrease
1912....	1000	.....	9.54	.....	2721	.....
1913....	877	— .123	9.23	— .032	2661	— .022
1914....	806	— .081	9.03	— .022	2760	+ .032
1915....	770	— .047	10.65	+ .180	3500	+ .271
1916....	640	— .165	13.66	+ .282	4779	+ .365
1917....	666	+ .040	17.81	+ .305	5768	+ .207

## Standardization in Great Britain

Standardization was the main topic at the recent fourth meeting of the Technical Committee of the Motor Industries in London. Recommendations were submitted for the consideration of the Engineering Standards Committee in regard to bolt type detachable wheels for pneumatic tires, tire sizes, loads and inflation pressures, road springs and chassis dimensions for carriage work. Three sub-committees were appointed to consider and report upon: (1) Fuel for internal combustion engines; (2) the formation of an education committee; (3) the proposed laboratory for internal combustion engine research. These are solely internal committees, and are not put forward in any way with a view to overlapping the work which is being carried out by other committees in the same direction. The standardization of automobile parts has now been under consideration by the Engineering Standards Committee for some considerable time, and the result of the work of the numerous sub-committees is beginning to bear fruit. The following reports have already been issued by that body, and may be obtained from the Engineering Standards Committee, 28 Victoria street, S. W. 1: No. 71, Report on British Standard Dimensions of Wheel Rims and Tire Bands for Solid Rubber Tires; No. 80, Report on British Standard Dimensions of Magnetos; No. 45, Report on Dimensions for Spark Plugs.

## Paint and Varnish

### Essential Details of the Finish

The late New York shows, and especially the automobile Salon, held at the Hotel Astor, had a lesson of importance for the vehicle painter. The Salon taught, first of all, that fine finishing has not gone out of fashion upon at least the best type and class of car. In the estimation of the writer the cars at this great show revealed a finish unsurpassed in the annals of automobile exhibitions in this country. This splendid exhibition of vehicles had a number of lessons for the painter, but the chief one, as above intimated, had to do with the finish. Among other things, this splendid finish, found upon all the cars showing a full lustre finish, taught the painter to value, perhaps to an extent not hitherto appreciated, the need of detail work. This fairly remarkable display of mirror-like surfaces proved beyond dispute that the finish is after all made up of many minor and major processes all applied with the sole aim in view of making the finishing coat of varnish a most perfect affair. The finish is really all the details of work brought to a high state of excellence in the finishing coat of varnish. This coat is simply a refinement of all the various processes applied during the development of the finish, beginning with the first coat of material. It would absolutely fail in its mission were the processes leading up to it anything less than skillfully worked out details each capable of standing alone as a finished product, but all necessary to rounding out the completed fabric which we have through many years of practice come to observe as the finish. The painters employed in the great factory shops have a deeper appreciation of the importance of the various coats, from first to last, and the processes fitting them into the structure of the finish, than the men of the smaller shops, and herein is to be found the secret of their success in producing matchless surfaces. When the application of the finishing varnish comes to hand it does not carry the labor and the mass of detail which the small shop painter brings to the work for the very clear reason that the surface is practically complete and needs only the refining effect of the finishing coat of varnish to make it so. The lesson then is, in effect, to bring out very carefully each detail of work and process so that at the end the finishing coat may not be expected to perform the duties properly delegated to the various processes preceding it and of which it is a part. The finish applied to the vehicle embraces all the coats of material used in the work, the priming coat being quite as much a finish, technically speaking, as the finishing coat of varnish. This is the understanding which we should have of the finish, and it is the understanding which will make for better work both in the matter of durability and appearance. In the Salon it was shown that striping has not gone out of fashion upon work for people who are in a position to pay the price. As one exhibitor put it in the presence of the writer: "Striping costs money these days, but if the car owner is willing to pay the cost it can be had, and it is really worth the money." There were many cars striped with double lines beautifully executed in colors perfectly harmonizing with

the field color. Ivory white, white, gold, blue, pale gray, green, and red lines were mostly in evidence. Scarcely a glazed line was to be seen, and it may reasonably be inferred that they have gone out of fashion. Painters in the small shops, and in shops located in small towns and provincial centers may well esteem the art of striping as a part of the finish which cannot, except at a disadvantage, be dispensed with. It is not always possible to develop a finish anywhere near as perfect as it is developed in the city shop, and the lines of striping help amazingly to camouflage or conceal the defects of the surface. For this purpose, then, striping is both desirable and necessary. Then the choice of colors may be made to materially assist the finish. Certain car bodies practically demand a color treatment of a special character, and where a combination of colors is employed this treatment quite often extends not only to the choice of panel colors but to the very careful selection of the striping colors, colors for the moldings, etc. Blue and black panels, maroon and black panels, and deep blue and black, form combinations which rarely fail to please the eye. The gray pigments are largely employed this season, and correctly so, for they are pigments which wear and look well, and stand abuse to the limit. They are neutral colors at all seasons, which is an important advantage in their favor. All these colors depend for their best display upon the working out smooth and clean of all the coats used for the building up of the finish. Both in the application of the material and in the surfacing processes applied the work needs to be clean and thorough and most painstaking.

### Painting the Car Maroon

Perhaps you may ask us to state off hand what maroon red, or maroon, as it is commonly termed, consists of principally. If told to shop mix a sample of maroon red from the ingredients at hand we should take one part of lampblack and eight parts of venetian red. This combination, however, would not produce the maroon which the show room unfolds; it would lack a certain richness which comes from glazing with a light wine color, for example, or Munich lake. An easier way to obtain a good working and looking maroon is to buy the material direct from some reliable color grinder. If the color is to be placed over an old paint foundation first scour the paint down close and hard, meanwhile looking sharply for cracks in the old surface. If these are found, and they extend deeply, better flow on a thin coat of equal parts of finishing and rubbing varnish. This will penetrate the crevices and aid to seal them up. Then if a quick job is desired at a comparatively small expense reduce some hard putty with turpentine and with a broad, half elastic putty knife, or scraping knife, proceed to draw putty the parts checked the worst. Apply this facing up material as smoothly as possible in order to save sandpapering work, and in working it out also try to press it into the checks, the main purpose being to get the cracks sealed against absorption. Let the glazing material dry very thoroughly, after which sandpaper it down well. Now we are ready for the color.

If it is the bought ready-to-use kind apply in the form of a solid color for the first coat; then with three ounces of the color thinned with turpentine to a cream-like consistency mix one pound of rubbing varnish, securing an intimate mixture. Flow this material freely to the surface, using for the large panels a half elastic bristle brush. This coat will materially enrich the field color. When dry break down the gloss with a sponge moistened with water and dipped in pumice stone flour. This will kill the gloss without doing injury to the color. For the coat of varnish to follow add, say,  $\frac{1}{2}$  oz. of the color to a pint of varnish; this will serve to maintain the purity of the field color. In due time knock down the lustre of this coat and s ripe, if this class of ornamental work is to be applied. Next coat must naturally be clear varnish. For a moderately priced job this coat may be rubbed down and the finishing coat of varnish applied; for a strictly fine job use another coat of rubbing varnish.

### Washing the Surface for the Finish

One of the best finishers it has been the writer's pleasure to know used to say that he cared not who applied the varnish so long as the washing up and cleaning of the surface was correctly performed. Perhaps this was a trifle overdrawn. It at all events serves to emphasize the importance of the cleaning and preparation of the surface for the finishing. The washing needs to be taken care of so thoroughly that there is no danger on this score. All parts of the surface will need flooding generously with water; in ample volume much of the dirt and adhesive substances will be carried away. All parts of the surface having moldings, and intricate corners, will need tooling out with the wash brush. The under edge of the body should have attention. Often much dirt and dust clings to the under edge. In drying off the water left after the flooding and washing process, the wash leather will need to only be lightly worked over the surface. A hard pressure is not desirable. The mist left after the light going over with the leather will evaporate and leave the surface in prime condition to finish upon.

### Refinishing Natural Wood Parts of the Car

It is necessary in the refinishing of the natural wood parts of the car to take off the old fractured and discolored finish, taking one car with another, and to do this two methods are available, to wit, using varnish remover or scraping the old finish off. In the use of the remover it will be found essential to procure the paste material. There are many makes of this material, most of them good and efficient. The paste, if of a good brand, will stay in place, and if carefully applied can be worked around the upholstery without soiling the fabric. There will be cases, of course, which had best be handled only after some of the upholstery furnishings are taken off at the point of contact with the wood. In all cases it is advisable to well cover the upholstery equipment with heavy muslin or other stout goods, and then work with exceeding care. Except in cases where the old finish has accumulated through years of successive applications of varnish one heavy smear of the remover will suffice to loosen up the old finish to the extent of allowing it to be removed directly down to the wood base. After removal, it is very necessary that the surface be given a thorough wash with turpentine, then with alcohol and finally sandpaper with either No. 1 or No.  $\frac{1}{2}$  paper. If the wood is stained it

will have to be treated with a solution of oxalic acid. This should be applied with a brush partly worn and then permitted to dry on the surface, after which it may be washed off with pure, soft water. This treatment will effectively bleach the wood and whiten it. In the event of the stains and discolorations going deeper than the oxalic acid is able to penetrate, it will be essential to scrape the outer film of wood down with a steel scraper, after which the acid treatment may be applied. Following the removal of the stains, apply wood filler quite as in the treatment of new wood, and allow it to set up and flatten out before rubbing it across the grain. Use tow preferably for rubbing off with. Rub across the grain and make sure that all the pores and grain cells are filled completely. Then apply at least three coats of orange gum shellac on all except the very light colored woods, and four coats if needed. Lay on plenty of rubbing varnish, working each coat down carefully by rubbing with water and pumice stone flour. Apply polishing varnish for the last coat, for a polish finish. Let dry through and then first water rub and then polish to a high, rich lustre.

### The Dull Finish for Automobiles

The automobile shows, notably the two New York exhibitions, displayed two distinct types of the dull finish, one of which, so far as we are able to see, has no advantages to commend it to the car owner. This is the house paint finish, consisting of oil paint, and mainly a fad with certain drivers of sporting instincts. We inspected some surprisingly fine examples of brush work in this house paint finish at the Hotel Astor Salon, and for an oil paint job the work certainly looked fine. One of the exhibitors agreed with the writer that it is not a desirable finish for a number of reasons, chief among which is that it is not cleanable; and a finish that cannot be cleaned is not durable, neither good to look at once it becomes dirty and begrimed. Another exhibitor told the writer that his firm turned out a number of cars painted with the oil paint finish last autumn and without an exception they all came back for repainting and finishing in the usual manner. If any reader is inclined to give the oil paint finish a try out he had best first consult some one with a car painted in this manner. In respect to the rubbed finish, that is, the finish developed through the application of varnish coats, with the last coat rubbed to a dull condition and then glossed by rubbing gently with sweet oil and rotten stone, it may be said that while this finish wears well and has a neat appearance and is greatly admired by not a few car users and owners, it is lacking in a certain measure of refinement and lustrous looks characteristic of the full lustre finish. After all is said and done there is no finish for the car which will stand up and hold its power of brilliancy and its protective capacity and submit to the abuse without going to pieces under it like the full lustre finish. It is the master finish, and the only finish that through washing and renovating can be renewed and up to a certain degree of wear made to look like new. A few years ago in the middle west there raged a craze for an enamel finish for vehicles, cars, railway trains, etc., but this was short lived, for it was found that the enamel would not stand cleaning and erosive processes. This enamel finish had about the same amount of gloss that the house paint finish displays, and in about every other particular it matched the latter. However, the full lustre finish is the finish of the masses; readers of this department are not advised to be concerned with the other kinds.

### A Lesson in Tire Economy

To better acquaint the truck owner whereby he can keep his truck tires and to show him the way with his problem of conserving a field and of value to his country at minimum cost, the B. F. Goodrich Rubber Co., Akron, O., has listed a sequence of the more common solid tire abuses, accentuating them with illustrations.

In the desire to get the very most out of the motor truck the owner is apt to overload his truck. The consequence is possibly more disastrous on the tires than on any other part of the truck. In the illustrations, No. 1 will give an idea of the damage accruing from this fault.

Below is a table of the maximum carrying capacity that single and dual tires should bear:

		Singles			Carrying Capacity				
Width of Tire	Height of Tire	Width of Wheel	Diam. of Wheel						
5 13/16	3 1/4	4 1/4	28	2,500					
			30						
			34						
			36						
			28						
6 13/16	3 3/4	5 1/4	30	4,000					
			32						
			34						
			36						
			30						
7 13/16	3 7/8	6 1/4	30	6,000					
			34						
			DUALS						
			Nominal Size of Tire		Width of Tire	Height of Tire	Width of Wheel	Diam. of Wheel	Carrying Capacity
			34 x 5		11 5/8	3 1/4	10	28	
36 x 5									
40 x 5									
42 x 5									
34 x 6									
36 x 6	13 5/8	3 3/4	12	30	10,000				
38 x 6									
40 x 6									
42 x 6									
36 x 7									
40 x 7	15 5/8	3 7/8	14	30	12,000				
				34					

There is positively no remedy, it is claimed, for a tire broken down from overloading. The reason is that the rubber has been compressed beyond the safe limit of elasticity. Little cracks occur and the deterioration commences.

Because a tire is solid many people believe it escapes one of the destroyers of the pneumatic tire, namely, heat. Yet it is a fact that heat is as disastrous to solid tires as it is to inflated tires.

Heat makes its appearance in overspeeding. When a truck is driven, loaded or unloaded, pell-mell over a smooth or rough road the heat that is generated within the tire, due to rapid displacement and road friction, is serious enough to cause a permanent injury. Usually it doesn't take long for disintegration to take place.

In illustration No. 3 we have the effect of skidding. Drivers should realize that their trucks will stop quicker if the brakes are applied gradually rather than quickly. Also they should be admonished against rapid turning of corners. Another thing: If one brake takes hold before the other the tire is bound to skid. This develops a flat spot on the tread and the next time the same emergency arises this same spot is the sufferer as the wheel will not skid until this one place on the tread has been reached.

On first glance one would say the tire in illustration

No. 4 had given satisfactory mileage. However, it is a case of the wheels being out of alignment. The effect upon the tire is a continual friction. The wheel out of kilter partly rolls and partly slides and the tread disappears quickly. If a driver notes a scaly appearance on his tread he should remedy his alignment immediately. Hard jolts cause this trouble.

Neglect of cuts is portrayed in the next illustration. The driver evidently had driven over broken glass, etc., and ignored the cuts, with the result they widened as the

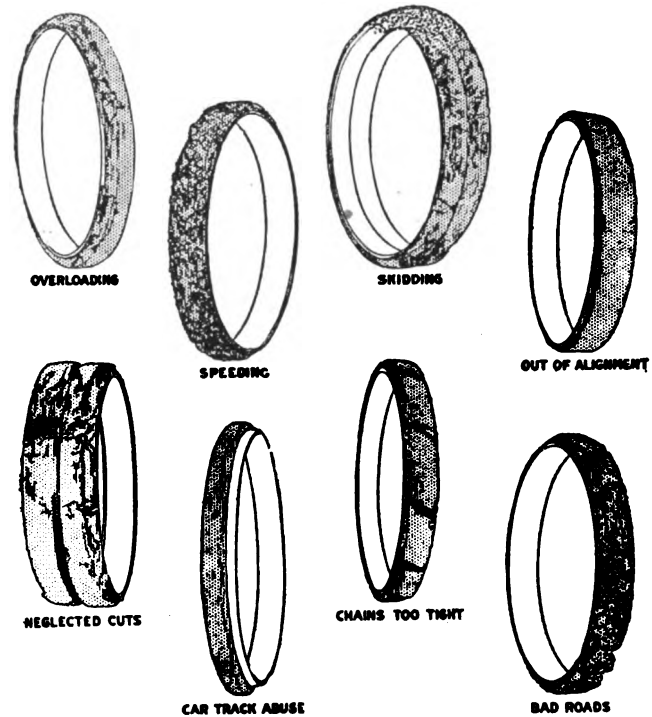

Illustrating the results of various forms of truck tire abuse. These drawings may be used as a key to ascertain just what is doing the damage and to rectify it

truck progressed. Tire cuts should be healed with cement or trimmed to lessen resistance.

In large cities the fault exemplified in illustration No. 6 is most noticeable. The truck has been driven in car tracks. One half the tire has carried the load while the other half has been cut to pieces in tracks.

All anti-skid devices have been found injurious to solid tires, but the least injurious is the loose chain. In the illustration the anti-skid contrivance has been of the permanent type and has eaten into the surface of the tire. Anti-skid devices should be used when only vitally necessary.

While bad roads cannot be avoided the pilot who uses the bad road simply because it will cut off distance risks permanent injury to his cushions.

### Ford to Make Its Own Carbureters

The Ford Motor Co., Detroit, has acquired the patents under which the Holley carbureter is produced, and also the factory in which Holley Bros. have been operating. The Holley Kerosene Carbureter Co., which was formed last December, has purchased from Holley Bros. their rights to the Holley kerosene carbureter and what remains of the gasoline carbureter business not sold to the Ford company. The Holley company will continue to manufacture carbureters.



## Leather Substitutes in Automobile Upholstery

Nearly every city of any importance has had its 1918 automobile show. Impressions were made and various criticisms heard. Of course, everybody realizes that the motor car industry has progressed rapidly during the last few years, but few, except those interested in the business, know that there were over 1,700,000 motor vehicles manufactured or put on the market in 1917. These alone had a value of over a billion dollars without giving the accessories necessary to the trade a thought, and everyone knows that the purchase of the "car" is not the last cost.

While cars may differ in many other respects they all have seats and same must be upholstered in something. That "something" will lead to an argument any time. Some years ago all cars were upholstered in leather, but the great foreign demand for hides as well as the ever increasing shortage of same has put the price beyond the reach of the manufacturer of the lower price cars, hence the many varieties of upholstery. Split leather in most cases does not prove satisfactory.

Seventy-five per cent of the number of cars sold are known as standard cars and sell for \$1,000 or less. Of this number 60 per cent are being upholstered with leather substitutes. The reason, of course, being the acute scarcity of leather. The better grades of leather substitutes have all the usual leather qualities and more. They perfectly reproduce the beauty and luxury of the finest leather upholstery, and are, in addition, grease and stain proof, as well as washable. Another big factor is that in place of varying lengths, widths, weights and thicknesses of leather, the substitute comes in rolls of standard length, width, weight and gauge. Instead of a wastage of nearly 40 per cent as with leather, and the trimming out of hollows, bumps, weak spots and rough edges, you get a material that is 100 per cent usable and of uniform strength, quality and efficiency throughout.

The substitute saves the car manufacturer time, skill and money in purchasing because he knows beforehand just what he will get and because it costs less than split leathers even though stronger. It saves time, labor and money in the factory, because it can be cut in large multiples by machinery and handled by less expert workmen. It insures a high class job of upholstering as it goes on smoothly, works easily and tufts beautifully, combining luxury, style and economy with an absolute guarantee of quality and service.

The year 1918 may not prove as big an automobile year as 1917 due to the fact that many large automobile plants are only working half their plants on their own company work, while the remainder is being used to help the government to the best advantage possible in its battle for democracy. Of course, there will be no shortage in the number of cars, but there may not be the wide range to select from. Therefore the purchase of a car in 1918 really necessitates more care than heretofore.

## Melting Aluminum Scrap

The fluxes commonly used in melting aluminum scrap, says Brass World, are fluorspar, cryolite, and salt. An excellent way of utilizing such material when a part of the scrap is small and not clean is first to melt a bath of aluminum, using solid material, and to allow it to reach a temperature of approximately 850 deg. C., then add the sweepings, etc., in such quantity that the bath will absorb

them without losing its liquidity. The bath is then reheated and more scrap charged, the process of charging and reheating being alternated until the crucible is as full of metal as desired. The metal will most likely be pasty, and a small piece of fused zinc chloride is added and the bath well stirred. The resulting action will free the mixed oxides and the metal will assume its natural fluidity. The crucible should be immediately emptied of aluminum before any reaction can occur between the metallic aluminum and the heated oxide on the one hand and the oxygen and nitrogen of the atmosphere on the other, as such reaction will consume metallic aluminum and greatly reduce the percentage recovered.

Now that aluminum is quoted at 60 cents per pound the recovery of all scrap with the least possible loss has assumed great importance. The great affinity of the molten metal for the chief constituents of the atmosphere renders the process difficult.

## Carriage Builders Meet and Discuss Trade Conditions

Standardization was advocated as a means of facilitating the securing of materials at a called meeting of carriage builders from all parts of the United States at Hotel Gibson, Cincinnati, January 15.

The purpose of the meeting was to discuss the railroad congestion, shipments of material and business conditions generally. The prevailing sentiment among the builders was that the taking over of the railroads by the government has already resulted in a noticeable improvement in shipments, although at present interfered with by weather conditions.

The carriage business was reported good and coming into its own again. Up to a year ago it was hard hit by the preference shown by buyers for automobiles, but farmers principally are again returning to the use of buggies. Some idea of the tremendous industry is gained from the fact that 400,000 horse-drawn buggies were manufactured in the United States last year.

Various committees were appointed to take up the matter of standardization and other plans considered. All present expressed their intention of attending the annual meeting of the Carriage Builders' National Association, to be held at Cincinnati next September.

Among those in attendance at the meeting were: Theo. Luth, president of the Luth Carriage Co., Cincinnati; William H. Roninger, president of the Banner Buggy Co., St. Louis; Frank Delker, president of the Delker Bros. Buggy Co., Henderson, Ky.; P. P. Hunter, president of the American Carriage Co., Cincinnati, and Ed Schlamp, president of the George Delker Buggy Co., Henderson, Ky. Of the 100 expected to be present only 33 were able to reach Cincinnati because of storm conditions. P. E. Ebrenz, St. Louis, presided, and George Houston, Cincinnati, was secretary.

## Good Roads Boom Autos in Hong Kong

George E. Anderson, American consul general at Hong Kong, sends word that there is an automobile boom in that territory as a result of the opening up of new residential sections. Coupled with this is the announcement of a comprehensive policy of road building and road improvement to better transportation to and from the outlying districts.

## Engine Development in 1917

Engine development during 1917 has been in detail. What changes there are have been more in the nature of refinements than extensive alterations, but these refinements have been of sufficient importance to lead to better performance in more important directions.

There are five systems on an engine which are of importance in relation to the manner in which the engine performs. These are gasoline feed, carburetion, lubrication, ignition and cooling. In all of these directions minor improvements have been made during the year.

Regarding gasoline feed, the vacuum tank has been improved so that there is now no possibility of the gasoline feed being too slow to take care of the higher speeds at which engines are run. The tank itself has been improved mechanically. The connections between tank and carbureter have, in a great many cases, been simplified and altered so as to cut out the chances of air lock and other irregularities which would tend to prevent regular flow of the fuel.

In one of the new cars the tank has been shifted from the cowl to the rear, and by so doing a great amount of space has been saved. In place of the cowl tank a vacuum tank has been substituted. Pressure feed systems where they are used are not altered, as these have been developed over a long period of time and have reached a satisfactory condition.

### Carburetion Improved

In carburetion one of the most important changes has been made. Great improvements have been put into the atomizing features of the carbureter, so that the fuel is more finely divided on entering the intake manifold. This finely divided mist, which is the most easy form to change into a dry gas, has been achieved by scientific improvements in the venturi arrangements in the carbureter and also in the construction of the jet passages. The straight tube type of carbureter seems to be on the increase.

It is probable that in lubrication one of the most significant changes in automobile engine design is taking place. There has been a marked trend toward pressure feed during the past few years, and this trend has continued and even accelerated during the past year. Engines are running at higher speeds, and this makes it necessary to be positive that the oil is forced into the bearings.

There is hardly a car at the present time which does not force the oil into the main bearings. From this point the systems vary, some continuing the force feed through a hollow crankshaft to the lower connecting rod bearings, while others allow the oil to overflow from the main bearings and lubricate the rest of the engine by the splash created by the lower ends of the connecting rods dipping into troughs which are kept full by the overflow from the main bearings. Both of these systems work out satisfactorily, although there is a very slight tendency toward the extended use of the hollow crankshaft.

### Ignition Also Better

The ignition of the engine does not differ materially from what it was a year ago. One of the manufacturers of ignition apparatus has placed on the market a closed circuit system in addition to the open circuit system which he was marketing previously. This new closed circuit type has been received favorably, and, taken together with the closed circuit type already on the market, would give

a slight tendency toward closed circuit ignition if the percentages among makers were calculated.

The difference between the closed and open circuit ignition is simple. In the closed circuit type the breaker points remain together until the time the spark is to occur, when they are snapped apart by the action of the breaker mechanism, after which they immediately close until the next spark is due, when the breaker mechanism brings them in and out of contact with an instantaneous motion of the breaker mechanism.

Each of these systems has its advantages. The main claim for the closed circuit is that the current has time to build up and a very hot spark is given, while the main claim for the open circuit is that no current flows until it is needed, hence economy of current.

### Cooling System Affected

It would hardly appear that the low grade of fuel which we are getting at the present time would have anything to do with the cooling system, yet it has. The reason for this is that due to the quality of fuel there is a greater tendency toward carbonizing than there was with the better grades.

The carbon tends to collect in the engine in parts which are not kept as cool as they should be, and hence great pains must be taken to circulate the water around all parts of the head of the engine and around the valve passages. A great amount of thought has been given to the cooling systems of the 1918 engines, and there is no doubt but they will be found to be more satisfactory in this respect than heretofore.

## Harsh and Slipping Clutches

Various remedies are suggested for harsh acting leather-faced cone clutches, but as a rule the relief is temporary. A more efficient repair is to insert a number of old hacksaw blades or similar strips of material under the leather at points diametrically opposite to one another.

To do this, the clutch cone should be removed or the clutch fully disengaged. Raise the rear edge of the leather with the blade of a screwdriver, so that a thin strip of metal may be driven underneath the leather. The insertion should extend from one side of the cone to the other. Rotate the clutch and insert a strip exactly opposite. Then place two intermediate pieces at equal distances from the first, and so on, using six or more. The strips must be opposite each other or the balance of the clutch will be disturbed.

The metal strips raise the leather slightly at six points, and these parts must be compressed before the grip of the entire clutch surface is obtained, and the engagement is gradual. The same method may be utilized to cure a slipping clutch due to the leather becoming hard, but the remedy will be temporary. If the action of the clutch is harsh after fitting a new leather, treat it with neatsfoot or castor oil, and if this fails to obtain the desired results sprinkle the leather lightly with powdered graphite, which will obtain a polished surface.

## "Jack" Moore Gets Married

D. J. Moore, (Jack), representative for many years of the Sherwin-Williams Co., Cleveland, O., surprised his many friends December 29 by getting married. The bride was Miss Elizabeth Dell Roberts, daughter of Mrs. Ruth Roberts, of Covington, Ky.

## Truck Committee Organized in Washington

With a view to aiding the government in breaking the present nation-wide freight congestion, a motor truck committee of the National Automobile Chamber of Commerce has been appointed for constant service in Washington.

This action was taken as a result of the recent convention of motor truck manufacturers held in New York, January 8. At this gathering, which voiced the unanimous desire of the nation's motor truck manufacturers to cooperate with entire unselfishness in any government measures, three men closely allied with war activities pointed out the need for such a committee. These men were Christian Girl, director of production, military truck division, quartermaster corps, U. S. A.; Hugh Chalmers, automobile industries committee, and Roy D. Chapin, chairman highways transport committee.

It was explained that the importance of the motor truck was constantly increasing, not only as a war factor but as a great and immediately available means for dealing with the freight congestion.

The committee, as organized recently, includes George M. Graham, Pierce-Arrow Motor Car Co., chairman; Windsor T. White, president of the White company; M. L. Pulcher, general manager of the Federal Motor Truck Co.; David Ludlum, president of the Autocar Co., and D. C. Fenner, Mack Motor Truck Co.

This committee will work largely in contact with the Highways Transport Committee, of which Roy D. Chapin is chairman, and which has charge of the responsible task of diverting short-haul traffic from railroads to the highways to relieve railroad and terminal congestion and restore normal distribution.

It will also be available to all other departments of the Council of National Defense or of the War Department for any service it may be able to render, and will give to manufacturers of motor trucks all over the United States such assistance as they may call for.

Through its direct touch with the motor truck industry and with shippers all over the United States, the motor truck committee should be in a position to lend signal aid.

Temporary headquarters have been taken in the Ouray Building, 8th and G streets, N.W., Washington, D. C.

## American Trade in Automobiles in Brazil

Formerly the automobile trade of Brazil was done entirely with France, Italy, and Germany. While the imports of automobiles have decreased greatly in the last three years, the United States is today practically the only important supplier which Brazil may look to.

Although four or five years ago the Brazilian market for automobiles was limited to large, heavy, expensive European cars, there has been a growing tendency there to look with favor upon the lighter and cheaper American makes of cars. Only a few years ago, roadsters or other small types of automobiles were practically unknown there, whereas today there is a growing demand for these types. American automobile tires and automobile accessories also have been introduced in larger quantities than formerly.

The market for motor trucks has been stagnant during the past year, owing to the existence of relatively large stocks of German motor cars, which were imported in large quantities before the war. Little has been accomplished by American manufacturers in introducing Ameri-

can motor trucks into Brazil thus far. This field is perhaps hardly one to be much developed at present, owing to the scarcity of good country roads in the interior.

## An Improved Gasoline Engine

A twin-six V-type gasoline engine has been designed for motor boats by C. D. Holmes, who designed a motor used by the Life Saving Service. The engine weighs 3,400 pounds, is 8 ft. 4 in. long and 3 ft. 10 in. high. Its especially high crankcase increases the accessibility of the parts as well as the rigidity and strength of the mechanism. All working parts are enclosed; but each part is accessible by covered handholes, through which the working parts can be taken without removing the motor from its base. At 1,000 revolutions per minute, this engine will develop 300 horsepower, without any strain whatever, and it can be speeded up to 1,400 revolutions, developing 400 horsepower, with little evidence of extra effort. One horsepower is produced for every nine pounds of engine, while the ratio of engines now in use is about 1 to 20. Production of parts of the engines has already been commenced, but none of the engines will be offered for private or commercial use during the period of the war.

## Jellinek-Mercedes Dead

A news dispatch announces the death at Geneva, Switzerland, of Emile Jellinek-Mercedes, the man who is responsible for the name Mercedes in the automobile, aircraft and motor boat industries. Jellinek was a wealthy Austrian who from 1880 to the outbreak of the war resided at Nice in southern France and acted as Austrian consul there. About 1900 Jellinek secured financial control of the Daimler Motor Co., of Caunstatt, Germany, and he claimed credit for having inspired Mayback, chief engineer of the Daimler works, with the idea of building a light and powerful chassis. This chassis, of 40 horsepower, weighed less than 2,200 pounds, whereas the 1899 Daimler model of 28 horsepower weighed about 4,000 pounds. The car was named the Mercedes for Jellinek's daughter.

## May Prohibit Chrome Imports

Chrome ore may soon be prohibited as a product to be imported in this country, or its importation largely reduced. The import trade in manganese and nitrates requires a large tonnage, which the government needs for exportation of supplies to Europe, and in consequence the United States aims to reduce this tonnage and use the American bottoms engaged chiefly in imported chrome ore in the war zone service. This will probably seriously affect some of our large steel plants which are depending on Cuba and other points outside of the United States for ore, and in turn display its effect upon the industry's steel allowance.

## Reduce Ford Car Production Fifty Per Cent

Reports that the Ford Motor Co., Detroit, will abandon the manufacture of passenger cars are denied by factory officials. The Ford plant will be largely devoted to war work on airplane and submarine des royer parts, with the result that passenger car production will be cut about 50 per cent. At present, the normal output of the factory is about 3,000 cars daily. A reduction of 50 per cent would bring this to 1,500 cars a day.

### Truck Owners' Third Conference

The third truck owners' conference will be held March 8 and 9 at the Hotel Astor, New York City. All present or prospective users of trucks are invited to attend and participate in the discussion.

Effort will be made to have topics handled so as to cover primarily principles of operation and maintenance in a way that will be quite as applicable to one business as another.

These truck owners' conferences are purely educational in character. No admission is charged and sales talk is not allowed by any one. Manufacturers of trucks, tires and accessories all agree to abide by this rule. The conferences are primarily to encourage those practical men who are meeting truck problems every day to exchange ideas with others who have perhaps found solutions for the various troubles that are uppermost now.

### Automobile Industry Uses Little Coal

Although the automobile industry ranks near the top in magnitude among all the manufacturing industries of the nation, it is a very light user of coal. According to the report of the U. S. Bureau of Census for the year 1914, it ranked in 42d place in tonnage of coal consumed. Less than half a million tons were used in automobile and motor truck plants in that year, while 31 other industries used more than 1,000,000 tons each, six used more than 2,000,000, and seven consumed more than 5,000,000 tons each. Steel works and rolling mills used more than 20,000,000 tons during that year, clay products companies more than 8,500,000, cement plants nearly 6,750,000, and paper and wood pulp mills more than 6,000,000 tons.

### Will Carry Large Stock of Bodies

The Commercial Motorbody Corp., organized to systematize the distribution of commercial bodies used by the motor trade, has leased the buildings that were to be occupied by the Essex Motor Corp., as the first unit of its warehouse system. The corporation will carry a large stock of bodies of all kinds to facilitate rapid delivery to commercial car distributors. Owing to the freight congestion, a warehouse system is greatly needed. The Detroit building covers 90,000 sq. ft. of floor space. Warehouse sites in Chicago and New York are now being considered and will be added before April 1.

### Kelly-Springfield's Big Profits

The Kelly-Springfield Tire Co. has just closed its most prosperous year with net sales aggregating \$14,000,000, and profits, before deducting taxes, of \$2,700,000. Allowing \$210,000 for the preferred dividend, almost \$2,500,000 remains for \$5,000,000 common stock—a return of 50 per cent, or \$12.50 a share. After the war tax is deducted the profits of the company will be about the same as those for 1916, and approximately equal to the total sales of the company five years ago. More than 2,200 pneumatic tires are being turned out daily, as compared with 1,400 a year ago.

About 200 board feet of wood is used in the actual construction of the average airplane. To obtain this material it is ordinarily necessary to work over about 1,500 feet of select lumber, which often represents all that can be used for airplanes of 15,000 board feet of standing timber.

### American Car Popular in South Africa

The year 1916 was a prosperous one for the sale of American automobiles in British South Africa. War conditions, which greatly hindered British automobile manufacturers, assisted largely in the sale of motor cars from the United States. Notwithstanding the inability of British manufacturers to compete, the American car would undoubtedly have predominated in sales, as it is more eminently suited to cope with South African road difficulties than those of British make. According to local statements, South Africa imported 3,372 private and 51 commercial cars from the United States during the fiscal year of 1916.

### Carriage Makers' Club Selects Directors

The Cincinnati Carriage Makers' Club at its regular monthly meeting in February elected several new tradesmen to membership. The nominating committee named the following for directors at the annual election in March: Joseph Wallenstein, Glen Perrine, W. F. O'Brien, E. J. Knapp, Henry Voss, E. G. Schick, I. O. Bauer and C. J. Rennekamp. Four will be elected.

### Pressing Claims Against Hal Motor

A petition asking that the Hal Motor Car Co. be adjudged an involuntary bankrupt was filed in the Federal Court at Cleveland, February 14, by the Universal Machinery Co., the Keyless Auto Clock Co., and the C. H. Hanson Co. The petitioners presented claims aggregating only \$1,500.

### Concession for Motor Bodies in Australia

Consul General Joseph I. Brittain cables from Sydney, under date of January 21, that an Australian customs decision now permits the importation of motor bodies ordered prior to August 10, 1917, if shipped from the factory before March 31, 1918.

An earlier concession from the prohibition of August 10 permitted the importation of automobile bodies ordered before the last-named date if shipped from the factory before January 1, 1918. Cars not ordered before August 10, 1917, will be admitted provided each complete car is accompanied by two chassis.

### Camber of Front Wheels

There is no specific standard for the camber or canting of front wheels outward at the top, says Popular Science Monthly, but it is done on most of the cars, to make it easier to steer and turn the curves than would be possible if the wheels were perpendicular. This camber of the front wheels of different cars varies from  $\frac{1}{4}$  to  $1\frac{1}{8}$  in. between inside felloe measurements. If the wheels stand too far outward at the top there is apt to be some binding effect at the axles, and the tire will not roll freely.

According to official and semi-official figures, the Italian motor industry produced, in 1916, 21,100 motor vehicles of all kinds and employed about 26,000 workpeople. The Fiat heads the list with 15,000 cars and 20,000 employes. This company claims to have supplied a greater number of motor vehicles to different allied armies than any other factory in the world, the number delivered up to the end of last year being 68,000.

# Vehicle Industry News in Brief

## Truck Builders

**Collier Motor Truck Co.**, Bellevue, O., will enlarge its plant by a brick and steel addition, 50 x 150 ft.

**Denby Motor Truck Co.**, Detroit, has let a contract for an assembling plant on its factory site at Holbrook avenue and the Grand Trunk Railway.

**Loyal Motor Truck Co.**, Lancaster, O., is preparing to manufacture a ½-ton truck and a 1,500-lb. "Loyal Special," featuring oversize and greater carrying capacity.

**Quaker City Motortruck Mfg. Co.**, Philadelphia, has been incorporated in Delaware with capital of \$1,000,000 by Charles L. Guerin, Joseph D. and John Morelli

**Service Motor Truck Co.**, Wabash, Ind., has erected two new buildings to take care of a government order for 500 five-ton trucks, to be supplied at the rate of 100 trucks per month.

**Four Wheel Drive Truck Co.**, Webberville, Mich., organized about six months ago with \$50,000 capital, has completed its plant and the manufacture of the first two-ton truck is under way.

**Arkansas Motor Truck Co.**, Little Rock, has been incorporated with \$10,000 capital stock and will manufacture industrial vehicles. Incorporators are S. M. Bolton, H. C. Wilson and J. O. Evatt.

**United States Motor Truck Co.**, Cincinnati, has obtained an order for a fleet of five-ton heavy duty trucks from the Keystone Construction Co., Philadelphia. The contract amounts to \$30,000,000.

**No-Chain Truck Unit Co.**, 3302 Lawton avenue, St. Louis, will begin the manufacture of the Truxton truck on a large scale at once. The company has been manufacturing the No-Chain truck unit only.

**Acme Motor Truck Co.**, Cadillac, Mich., formerly styled Cadillac Auto Truck Co., has increased its capital stock to \$1,000,000. The company is building a large addition to its plant, and plans to double its output in 1918.

**Muskegon (Mich.) Engine Co.** has started production on its two-ton truck. One truck has been completed and as soon as machinery is installed the plant will be speeded to full capacity. At present about 20 employes are at work.

**Four Wheel Drive Automobile Co.**, Clintonville, Wis., which is executing government contracts for quadruple drive army trucks, has increased its working force to 1,200, and is advertising for all of the skilled and unskilled help it can get.

**Reliance Motor Truck Co.**, formerly styled Racine Motor Truck Co., has started the construction of the first unit of its proposed new plant at Appleton, Wis. This will be 76 x 300 ft. It is expected that the work will be completed by May 15.

**Bell Motor Car Co., Inc.**, York, Pa., will manufacture a new 1½-ton truck with internal gear drive and wheelbase

of 112-124-136 in., in the factory it recently purchased from the Pullman Motor Car Co., York. It will also bring out a new model Bell passenger car.

**Grant Motor Car Corp.**, Findlay, O., is designing a new 3½ ton, internal gear truck, and expects to have a model completed in two or three months. No details are available yet, except that the truck will have Torbensen rear axle and a Continental engine.

**Oneida Motor Truck Co.**, Green Bay, Wis., is operating in its new factory, 150 x 476 ft., which affords 70,000 sq. ft. of floor space. It intends to ultimately increase its production to 275 trucks a month. The company's capital stock has been increased from \$300,000 to \$500,000.

**Norman Motor Truck Corp.**, Richmond, Va., recently incorporated in Delaware with a capital of \$5,000,000, has acquired 100 acres at Doswell, 20 miles from Richmond, and plans the erection of a plant for the manufacture of heavy motor trucks. Robert W. Crawford is president, and James H. Price vice-president.

**Lane Motor Truck Co.**, Kalamazoo, Mich., will increase its capital stock from \$25,000 to \$225,000. The increase will be used for speeding up production to ten trucks a week. In the spring, an addition, 60 x 100, will be erected as a painting department. Of the proposed stock issue, \$50,000 will be set aside and \$150,000 will be sold.

**Noble Motor Truck Corp.**, Kendallville, Ind., has been incorporated with \$1,000,000 capital to manufacture motor vehicles. The directors are C. J. Munton, John Hauff, George D. McLeod, G. M. Patterson, H. L. Postle, A. M. Jacobs and W. G. Roberts. State Senator C. J. Munton is president; G. M. Patterson, secretary, and H. W. Bradtmiller treasurer.

**Moreland Motor Truck Co.**, Los Angeles, is now operating at full capacity the first unit of its new plant at Burbank. New units now planned will be constructed at an early date. The company is now manufacturing all parts for its trucks with the exception of motors, steering wheels and columns, controls, etc. All clutches, transmissions and frames are being produced at the works. Watt L. Moreland is general manager.

## Body Builders

**Hayes-Ionia Body Co.**, Grand Rapids, Mich., will build an addition of 230 x 110 ft., three stories in height.

**Union City (Ind.) Body Works** has been taken over by the Wright Aeroplane Co., Dayton, O., and will be used to manufacture aeroplane parts.

**Detroit Shell Co.** has purchased the plant of the Springfield Body Co. from B. F. Everett, the company's trustee. Buildings, machinery and land brought \$500,000.

**Markley Commercial Body Co.**, Pontiac, Mich., has been formed with a capital of \$25,000. The incorporators are the following: Verne G., Mabel J., and Jesse W. Markley.



**Walton Auto Body Co.**, New York, has leased for five years a four-story building at Avenue D and Eleventh street. This is being equipped with machinery for the manufacture of airplane frames.

**Commercial Car Body Co.**, Dover, Del., has been incorporated with a capital of \$1,500,000 to manufacture commercial bodies for automobiles. James H. Hughes and Mark W. Cole, Dover, are the incorporators.

**National Body & Mfg. Co.**, Nashville, Tenn., has been incorporated with a capital of \$75,000, to manufacture motor trucks and automobile bodies. C. R. Wood, Louis Steinberg and J. K. Cravens are the incorporators.

**Auto Body Co.**, Lansing, Mich., will manufacture 75 additional bodies daily. The company has received an order from the Scripps-Booth Corp., Detroit, for 12,000 bodies. At present the production amounts to 300 bodies daily, of which 100 are sent to the Olds Motor Works.

**Commercial Auto Body Co.**, Chicago, in extending its business of building bodies for motor trucks, has found it necessary to remove its plant to larger quarters at 2540 Wabash avenue. C. A. Weaver, who heads the organization in its new home, has had broad experience in designing commercial bodies.

**Mifflinburg (Pa.) Buggy Co.** has filed notice of change of name to the Mifflinburg Body Co. It proposes to discontinue the manufacture of horse-drawn vehicles and devote its plant to the manufacture of automobile bodies. A three-story addition, 60 x 208 ft., is now in course of construction at a cost of \$60,000.

**Heil Co.**, Milwaukee, manufacturer of electrically welded steel dump bodies for motor trucks, has received a second government contract for a special design of dump body for use on truck chassis used in road building and bridge construction. The company recently completed a large addition to its plant, to be used exclusively for this work.

### Car Builders

**Studebaker Corp.**, South Bend, Ind., will build a dry kiln, 112 x 244 ft., to cost \$50,000.

**Paige-Detroit Motor Car Co.**, Detroit, has 20 per cent more cars booked on order at present than it had last year.

**Hupp Motor Car Co.**, Detroit, has been producing 1,250 cars per month since November, or between 40 and 50 cars per day.

**Mason Motor Co.**, Flint, Mich., has ceased to exist. Its plant is now the motor and axle department of the Chevrolet Motor Co.

**Columbia Motors Co.**, Detroit, maker of the Columbia six-passenger cars, has received a big government order for trailers, to be shipped to France.

**H. H. Franklin Mfg. Co.**, Syracuse, N. Y., has decreased its automobile output 40 per cent and is devoting the equipment thus released for work on parts of Rolls-Royce motors for the British government.

**Jordan Motor Car Co.**, Cleveland, manufactured and shipped 1,727 cars during 1917, the total volume of business amounting to \$3,000,000. More cars were sold in the last three months than any other quarter of the year.

**Mutual Motors Co.**'s plant in Detroit, which formerly manufactured the Marion-Handley car, was sold at public

auction February 7, in Jackson, Mich., to the Susquehanna Finance Corp., of Buffalo. The sum of \$212,000 paid for the plant will enable the referees in bankruptcy to pay about 30 cents on the dollar.

**Duesenberg Motors Corp.**, Elizabeth, N. J., has purchased the buildings and equipment of the Fiat Co., Poughkeepsie, N. Y., in order to obtain immediately a large amount of machinery with which to carry on the production of airplane engines for the government. The Fiat company will continue to occupy a part of the buildings and the production and assembly of Fiat cars will go on much as usual.

### Parts Makers

**Timken-Detroit Co.**, Detroit, has let contract for a three-story brick and reinforced concrete addition to its plant.

**Standard Roller Bearing Co.**, 5001 Lancaster avenue, Philadelphia, has filed plans for improvements in its plants to cost \$10,000.

**Smith Wheel Co., Inc.**, Syracuse, N. Y., has increased its capital from \$1,000,000 to \$3,000,000 and will build several additions to its plant.

**Hayes Wheel Works**, Anderson, Ind., has a government contract for 1,000 automobile wheels per day for a year. The plant will be enlarged.

**Hess-Bright Mfg. Co.**, Front street and Erie avenue, Philadelphia, manufacturer of ball bearings, has increased its capital from \$1,250,000 to \$1,630,000.

**Hess Spring & Axle Co.** suffered a loss by fire of three out of five buildings on January 23 at their plant at Carthage, a suburb of Cincinnati. The loss is estimated at \$100,000. Rebuilding plans have not yet been announced.

**Bimel Spoke & Auto Wheel Co.**, of Portland, Ind., are putting in a separate department for building *Escort* wheels. A complete new outfit of machinery is being installed in a shop entirely separate from the auto and truck wheels so that any change in demand for the other wheels will not interfere with this new department. The capacity will be about 100 sets a day of ten hours.

**Perlman Rim Corp.**, Jackson, Mich., one of whose plants was destroyed January 7 with a loss of \$100,000, is taking care of its production by running double shifts in its other two plants. The loss to the building was \$60,000, to the machinery \$30,000, to stock \$10,000. Officers of the company are Clarence M. Day, president; Charles M. McFarland, vice-president; L. F. Bomhoff, secretary and treasurer.

**Falls Motors Corp.**, Sheboygan Falls, Wis., has a government contract for military truck engines which will occupy its maximum capacity until June 1, 1919. The initial order is for 2,000 motors, delivery of which will begin in March to the Kissel Motor Car Co., Hartford, Wis. Upon the completion of this order, further specifications will be given. Angelo R. Clas is secretary. The working force will be considerably enlarged after March 1.

Pat—"How much did ye pay for thim eggs?"

Bridget—"Fifty cents a dozen, sure."

Pat—"We can't afford to ate eggs at thot price. Put thim in the celler till eggs gits chaiper, and then we'll ate thim."

## Cutting Speeds

In turning and shaping metal on the lathe, planer or shaper there are certain speeds which must not be exceeded or the tool will be injured. In taking a roughing cut on the lathe on wrought iron the speed must be lower than when a finishing cut is being made, because of the fibrous nature of the metal, but with the other metals the speed can be the same with roughing as finishing.

In the case of brass the feed is the same at all speeds, and whether a roughing or finishing cut is being made, though with cast iron the speed should be slower in making finishing cuts. With wrought iron and steel, the feed is faster on the finishing cuts than on roughing cuts. As the diameter of the work turned is increased, the number of revolutions is reduced in proportion. Cutting speeds and feeds are as follows:

Diameter of work in inches	Roughing cuts		Finishing cuts	
	Speed in r.p.m.	Feed	Speed in r.p.m.	Feed
		<b>Brass</b>		
1 and less	380	25	380	25
1 to 2	318	25	318	25
2 to 4	255	25	255	25
4 to 6	229	25	229	25
6 to 12	191	25	191	25
		<b>Iron, Cast</b>		
1 and less	121	20	121	20
1 to 2	112	20	112	16
2 to 4	96	20	96	10
4 to 6	80	16	80	6
6 to 12	63	14	63	6
12 to 20	63	10	63	4
		<b>Iron, Wrought</b>		
1 and less	112	25	121	30
1 to 2	80	20	96	30
2 to 4	80	20	80	25
4 to 6	72	20	72	25
6 to 12	63	15	72	20
12 to 20	57	12	58	16
		<b>Steel</b>		
1 and less	63	25	63	30
1 to 2	57	25	57	30
2 to 3	57	25	48	30
3 to 6	48	20	48	30

## Why Annealing

The reason for annealing steel and other metals is to soften them for one purpose or another. This consists of heating and cooling very slowly as compared with quenching, which produces hardness. Cylinder castings of iron are treated by this process to remove internal strains set up between thick and thin parts. Many notably hard steels are annealed to permit of easy machining, while in parts subjected to shocks which must, however, sustain other loads, the hardening is necessary in order to bring out the best qualities of the material. This requires careful working for physical properties, then equally skillful annealing to remove all internal strains.

## The Old Man Comes Back

One year ago an old man was working on the streets of Bridgeport at \$2 per day. He was an expert pattern maker and something of an inventor on the side. There was but one thing against him, he was ancient and slow. There was no place for him save on the streets of the city.

Today he is making patterns for a concern in this city and earning \$4.50 per day. And he is worth every cent they pay him, for he is a thorough workman, intelligent and competent for every task. He is a sharp contrast to the boys that formerly held down the job. But he is turning out more work than they could turn out, for his task is well done and there are no return jobs. This could not be said of all the youths who held down such responsible jobs.

This is a typical case. The old man is coming once

more into his own. It has long seemed to be a denial of all our principles of efficiency to turn off the man who through many years had learned to do a thing well, and hire a man who could produce only quantity.

The hour demands quality as well as quantity, and the old man, the seasoned man, is the man to put quality in his work.

The opportunity is here now for many a man with gray in his hair to prove not only that he is a good workman in time of war when the youth is with the colors, but that he is a good workman at all times.—Bridgeport Telegram.

## Death of Joseph Girardin

Joseph Girardin, 74 years old, a pioneer of Wyandotte, Mich., and one of the city's first aldermen, died January 26, of heart failure. Mr. Girardin was engaged in the business of manufacturing wagons and carriages until a short time prior to his death. He was born in Amherstburg, Ont., in 1843 and lived in Wyandotte almost continuously. The widow, four sons, one daughter and eight grandchildren survive.

## Death of British Pioneer

Ernest Hooper, managing director of Hooper and Sons, Ltd., the well known carriage builders, died recently. Mr. Hooper was well known in the Lancashire trade, and was prominently connected with the old Northern Masters' Association, and latterly with the Lancashire and Cheshire Section of the National Federation of Vehicle Trades. He enjoyed the respect of a very wide circle of friends, and will be much missed.

## Solving Transportation Problem With Trucks

Operation of a new automobile freight service between Springfield and New York was begun on December 31 to help solve the railroad transportation problem. A five-ton truck will be operated in each direction and, if successful, more will be added.

## WANTS

Help and situation wanted advertisements, 1 cent a word; all other advertisements in this department, 5 cents a word; initials and figures count as words. Minimum price, 30 cents for each advertisement.

**Wanted**—Copies of The Hub of May and July, 1916. Must be in good condition. Address Trade News Publishing Co., corner Elm and Duane streets, N. Y. City.

### PATENTS

**Patents**—H. W. T. Jenner, patent attorney and mechanical expert, 606 F St., Washington, D. C. Established 1883. I make a free examination and report if a patent can be had and exactly what it will cost. Send for circular.

### HELP WANTED

**Wanted**—Working foreman in woodworking department of custom commercial body factory. Must have ability to do fine work and manage workmen; also some designing ability. Apply Box 888, Ogden, Utah.

### SITUATIONS WANTED

**Wanted**—A position as superintendent, general manager or assistant with some live company in the automobile line. Am a practical body man. Have had vast experience in handling men. Address, Experience, care The Hub.

The  
**Laidlaw Company**  
Inc.

New York City

.....

**Automobile  
Fabrics**

.....

**A Fabric for  
Every Purpose  
For Closed, Open or  
Convertible Bodies**

**steel  
stampings**

*especially for*  
**COMMERCIAL TRUCKS**

**The Pressed Steel Company  
Wilkes-Barre, Pa.**

**Index To Advertisers**

Barrell Co., Wm. L.....	38
Bradley, C. C., & Son.....	41
Bridgeport Coach Lace Co.....	3
Century-Plainfield Tire Co.....	39
Century Steel Co. of America, The.....	4
Columbus Bolt Works.....	42
Cowles, C., & Co.....	40
Crane & MacMahon, Inc.....	43
Decker, J. C.....	40
Dixon, Joseph, Crucible Co.....	7
Dowler, Chas. L.....	40
Doxey, N. D.....	39
DuPont Fabrikoid Co.....	38
Eccles, Richard, Co.....	6
G & O Mfg Co.....	43
Gray, Peter, & Sons, Inc.....	41
Hartford Auto Parts Co.....	3
Hotel Rochester .....	41
Johnston, R. F., Paint Co.....	40
Judd & Leland Mfg. Co.....	39
Keratol Co., The.....	38
Laidlaw Co., The.....	37
Mulholland Co., The.....	40
Norton Grinding Co.....	5
Parrott Varnish Co., The.....	2
Paulson, Thomas, & Son, Inc.....	42
Pierce Co., F. O.....	42
Pittsfield Spark Coil Co.....	2
Porter, H. K.....	43
Pressed Steel Co.....	37
Quickwork Co., The.....	43
Rome-Turney Radiator Co.....	6
Russell, Birdsall & Ward Bolt & Nut Co.....	41
Sheldon Axle & Spring Co.....	Front cover and 8
Standard Oil Cloth Co., Inc.....	Back cover
Technical School for Automobile Draftsmen and Mechanics .....	38
Wayne Wheel Co.....	2
West Tire Setter Co.....	43
White-Quehl Mfg. Co.....	40
Wilcox Mfg. Co., D.....	43
Wiley Co., C. A.....	6
Wing, Chas., Co.....	40
Yoder Company, The.....	4

Please mention "The Hub" when you write

# Keratol LEATHER SKINS

For the car where leather has always been used



**PRICE**  
*Within Reason*  
**QUALITY**  
*Maintained*

**W<sup>m</sup> L. BARRELL Co.**      **8 THOMAS ST.**  
**NEW YORK**



REG. U. S. PAT. OFF.

**Truck  
Special**

**As Rugged as the Service  
for Which It Is Made**

Behind the firing line or on the busy street  
TRUCK SPECIAL meets every  
test of service.

The United States Government is using leather  
substitutes for Truck Upholstery. You will if you  
investigate the real economy and splendid wearing  
qualities of TRUCK SPECIAL.

Let us send you samples and quote prices

**DU PONT  
FABRIKOID CO.**

WILMINGTON,  
DEL.



Photograph from Underwood & Underwood, N. Y.

## Vehicle Mechanics

Desiring to improve their present  
Condition should attend the

## TECHNICAL SCHOOL

For

## Automobile Draftsmen and Mechanics

Supported by the

The National Automobile Chamber of Commerce, Inc.

The object of the School is to teach men to design  
vehicles and make working drawings, and to otherwise  
facilitate their work in the shop. Only those men em-  
ployed in carriage or automobile building or their acces-  
sory trades are admitted to its privileges.

The classes are conducted in three divisions, viz.: Cor-  
responding, Day, and Evening. The former is open during  
the entire year, while the day and evening classes are in  
session only from October 1 to April 1.

The tuition is moderate.

For prospectus and full particulars, write to the instructor,

**ANDREW F. JOHNSON,**  
20 West Forty-fourth St.,  
**NEW YORK CITY**

Please mention "The Hub" when you write.



# ANCHOR WELDING COMPOUND

MANUFACTURED BY  
**N. D. DOXEY, ELMIRA, N. Y.**

ANCHOR WELDING COMPOUND will weld hardest steel. Will not peel apart at the weld, thus losing the heat, nor burn up when flowing on the lap. Will weld without the use of hammer. Place two flat surfaces together in the fire, smelting the Compound liberally on the parts and press pieces together firmly with tongs, and weld will be complete without a stroke of the hammer. It will not require any iron filings to be added in welding as in some other compounds. It does the work itself. A weld made with ANCHOR COMPOUND leaves the welded parts of equal strength with solid parts of the metal. Cannot be damaged by dampness nor by heat.

Your Welding Compound gives entire satisfaction. In welding steel of high carbon, it fluxes quick and the steel appears like iron, and can be worked at a white heat. I have tried all other compounds in the market and can pronounce yours the best. It flows where you want it to flow.  
C. H. KILMER, Elmira, N. Y.

We take pleasure in stating that we have been using your Welding Compound for several years and find it a most excellent article, and can recommend it highly. Yours truly,  
THE LAFRANCE FIRE ENGINE CO.,  
W. Falck, Gen. Manager, Elmira, N. Y.

Is used by U. S. Navy and C. & N. W. Ry. Co. and many others.

IN USING do not throw the Compound from the surface to be welded, but cup the scarf, and in light work turn the piece, when ready for welding, so that the Compound will flow evenly over the surface to be welded, which it will readily do, flowing like oil. In heavier work, add compound to surface to be welded, as heat nears welding point, so that surface to be welded is covered with fused compound.

# THE HARLEM TIRE PUMP

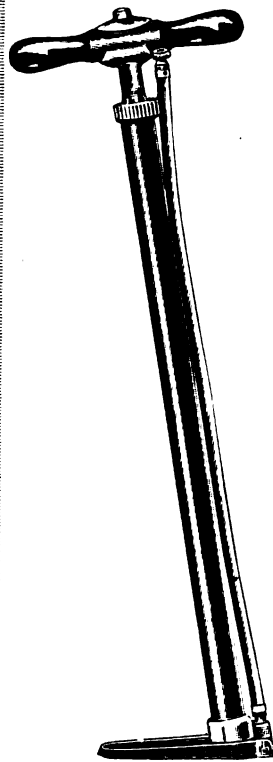

A Single Action,  
Thoughtfully  
Designed

It has  
Large Reinforced  
Handle;  
Steel Tube, 1 1/2 x 22;  
Heavy Steel Plunger  
Rod;  
Selected Kip Cup;

Collapsible Base, that  
cannot be pushed into  
mud or sand when the  
pump is in operation.

Simple and Sturdy

MADE BY  
**Judd & Leland Mfg. Co.**  
Clifton Springs, N. Y.



# Superbar Tires

"Service Tires"

Made of high grade fabric and best grades of pure rubber to meet the demand of those who seek a good Standard Quality Tire giving maximum amount of service for money invested.

Built by HAND throughout.

SUPERBAR Tires are the result of many years of scientific experimenting and combine quality of material, skill in workmanship and a maximum of road resistance.

Adjusted on 3,500-mile basis. Ford sizes, 4,500-mile basis.

Splendid agency opportunities are available; particulars on request.

**Century-Plainfield Tire Co.**  
Plainfield, N. J.

Century-Plainfield Tire Company, a subsidiary of the Rubber Metals Corporation, exclusive manufacturers of the Rimco Rubber Products by the Elchemco process

Please mention The Hub when you write



## BUSY BUYERS BRIEFS

### JOHNSTON'S KRAKNO

Color Card Free  
\$3.50 per gallon

The R. F. Johnston Paint Co.  
Cincinnati, Ohio

### THE CHARLES WING CO.

Established 1848

Manufacturers and Wholesale Dealers in  
**AUTOMOBILE AND CARRIAGE  
HARDWARE AND TRIMMINGS**  
AMESBURY, MASS., U. S. A.

### Why Not Have the Best?

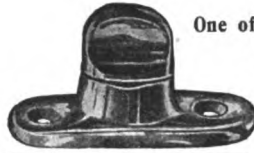

One of a Large Variety

G. Cowles & Co.  
NEW HAVEN,  
CONN.

### J. C. DECKER

MONTGOMERY, PA.

Manufacturer of

### Carriage, Skate and Pad Straps

Side Loops, Bridle Fronts, Tail Ties, etc.

### CHARLES L. DOWLER

CARRIAGE AND WAGON HARDWARE

108 North Third St., Philadelphia, Pa.

### CUSHION MANUFACTURER

Pure Stearic Acid Candles. Wheel Stock. Snow  
Flake Axle Grease.

### MULHOLLAND BUGGY SPRING

Reduces weight of springs one-half.  
Made in one size only but will fit bodies  
of all widths.

Write for further particulars and prices.  
THE MULHOLLAND CO. DUNKIRK, N. Y.

### White's Brazing Sleeves



LINED



UNLINED

For applying Rubber Tires  
Send for Samples.

### WHITE-QUEHL MFG. CO.

431 E. Pearl St.  
CINCINNATI, OHIO

## CLASSIFIED INDEX

For Addresses See Alphabetical Index  
and Advertising Pages

#### ANTI-FRICTION METALS

Thomas Paulson & Son, Inc.,  
Brooklyn, N. Y.

#### AUTOMOBILES

American Motors Corp., Plain-  
field, N. J.

#### AUTO FABRICS

Barrell, Wm. L., Co., New York  
Keratol Co., The, Newark, N. J.  
Laidlaw Co., Inc., The, New  
York  
O'Bannon Corp., New York City  
Standard Oil Cloth Co., New  
York City.

#### AUTO PARTS

Hartford Auto Parts Co., Hart-  
ford, Conn.

#### AXLES (Including Ball and Roller Bearing)

Sheldon Axle & Spring Co.,  
Wilkes-Barre, Pa.

#### BOLTS AND NUTS

Columbus (O.) Bolt Works Co.  
Russell, Burdsall & Ward Bolt  
& Nut Co., Port Chester, N.Y.

#### BOLT CLIPPERS

Porter, H. K., Everett, Mass.

#### BRAZING SLEEVES

White-Quehl Mfg. Co. Cincin-  
nati, O.

#### DIES

Bliss Co., E. W., Brooklyn, N.Y.  
(Sheet Metal Working).

#### FORGINGS

Eccles, Richard, Auburn, N. Y.  
(Carriage, Drop).  
Williams, J. H., & Co. Brook-  
lyn, N.Y. (Automobile, Drop)

#### FIFTH WHEELS

Wilcox Mfg. Co., D., Mechanics-  
burg, Pa.

#### HARDWARE (Carriage, Wagon and Automobile)

Columbus (O.) Bolt Works Co.  
Dowler, Chas. L., Philadelphia.  
Eccles Co., Richard, Auburn,  
N. Y.  
Wilcox Mfg. Co., D., Mechan-  
icsburg, Pa.  
Wing Co., Chas., Amesbury,  
Mass.  
Cowles, C., & Co., New Haven,  
Conn.

#### LEATHER SUBSTITUTES

Barrell, Co., Wm. L., New York.  
DuPont Fabrikoid Co., Wil-  
mington, Del.  
Keratol Co., The, Newark, N. J.  
O'Bannon Corp., New York City  
Standard Oil Cloth Co., New  
York.

#### LUBRICANTS

Dixon, Jos., Crucible Co., Jer-  
sey City, N. J.

#### MACHINERY AND TOOLS

Bliss Co., E. W., Brooklyn, N.Y.  
Norton Grinding Co., Worces-  
ter, Mass.  
Pettingell Machine Co., Ames-  
bury, Mass.  
Simmons Machine Co., Inc.,  
Albany, N. Y.; Singer Bldg.,  
New York City.  
Smith, H. Collier Detroit, Mich.  
West Tire Setter Co., Roches-  
ter, N. Y.  
Williams, J. H., & Co., Brook-  
lyn, N. Y.  
White-Quehl Mfg. Co., Cincin-  
nati, O.  
Yoder Co., The, Cleveland, O.

#### MACHINERY (Metal Working)

Bliss Co., E. W., Brooklyn, N.Y.  
Pettingell Machine Co., Ames-  
bury, Mass.  
Quickwork Company, Detroit,  
Mich.  
Yoder Co., The, Cleveland, O.

#### METAL STAMPINGS AND NOVELTIES

Gray, Peter, & Sons, Inc., Cam-  
bridge, Mass.  
Pressed Steel Co. of New York,  
New York City.

#### PATENTS

Jenner, H. W. T., Washington,  
D. C.

#### PAINTS AND COLORS

Johnston Paint Co., R. F., Cin-  
cinnati, O.  
Pierce Co., F. O., New York.  
Willey Co., C. A., Hunter's  
Point, N. Y.

#### PRESSES

Bliss Co., E. W., Brooklyn, N.Y.  
(Drop, Power).

#### RADIATORS

G. & O. Mfg. Co., New Haven,  
Conn.  
Rome-Turney Co., Rome, N. Y.

#### SCHOOL FOR DRAUGHTS- MEN

Mechanics' Institute, New York

#### SHAFT COUPLINGS

Bradley & Son, C. C., Syracuse,  
N. Y.  
Eccles Co., Richard, Auburn,  
N. Y.

#### SPARK COILS

Pittsfield Spark Coil Co., Pitts-  
field, Mass.

#### SPRINGS

Mulholland Co., Dunkirk, N. Y.  
Sheldon Axle & Spring Co.,  
Wilkes-Barre, Pa.

#### STEEL

Century Steel Co. of America,  
Poughkeepsie, N. Y.; Sales  
office, 120 Broadway, N. Y.

#### TIRES

Century-Plainfield Tire Co.,  
Plainfield, N. J.  
TIRE PUMPS  
Judd & Leland Mfg. Co., Clifton  
Springs, N. Y.

#### TOOLS

Williams, J. H., & Co. Brook-  
lyn, N. Y.

#### TRIMMING MATERIAL

Bridgeport (Conn.) Coach Lace  
Co.  
Decker, J. C., Montgomery, Pa.  
Wing Co., Chas., Amesbury,  
Mass.

#### UNIVERSAL JOINTS

Hartford (Conn.) Auto Parts  
Co.

#### VARNISH AND JAPAN

Parrott Varnish Co., Bridgeport,  
Conn.  
Pierce Co., F. O., New York.  
Willey Co., C. A., Hunter's  
Point, N. Y.

#### VARNISH RENOVATOR

Poughkeepsie (N. Y.) Utilities  
Corp.

#### WELDING COMPOUND

N. D. Doxey, Elmira, N. Y.

#### WHEELS

Crane & MacMahon, Inc., New  
York City.  
Hoopes Bros. & Darlington,  
Inc., West Chester, Pa.  
Wayne Wheel Co., Newark, N.J.

#### WOOD BENDINGS, WHEEL STOCK, ETC.

Crane & MacMahon, Inc., New  
York City.

Please mention "The Hub" when you write



The machinery of the country is running at top speed to supply war needs. Machines are supplementing man power to make up for labor

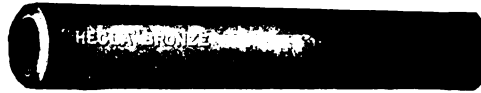

shortage. The wheels **MUST** be kept turning—automobiles, gas, oil and steam engines, railway trucks, generators and everything that runs in bearings.

## “HECLA” ANTI-FRICTION BRONZE

will keep them moving, smoothly and efficiently. This alloy is the result of 32 years' experience and research. “HECLA” WILL NOT CUT the journal or pin under the severest service conditions. Will not pound out or break, MACHINES CHEAPLY and has NO SUPERIOR regardless of price. Let us send the little “Hecla” booklet. We also make Castings—finished or rough, in Brass, Bronze, Aluminum, Hydraulic Metals, Copper, Acid Metal.

**BRASS FOUNDERS ENGINEERS** **THOMAS PAULSON & SON, Inc.** 97 SECOND AVENUE BROOKLYN, N. Y.

# F. O. PIERCE COMPANY

## NEW YORK, U. S. A.

Manufacturers of High Class Pigment Colors

## FOR AUTOMOBILE PAINTING

Made from ORIGINAL FORMULAE.  
Colors ground in Japan and other MEDIUMS  
to meet any SYSTEM of APPLICATION

We can now supply Uzatona in Japan, Oil or Varnish. Prices upon application

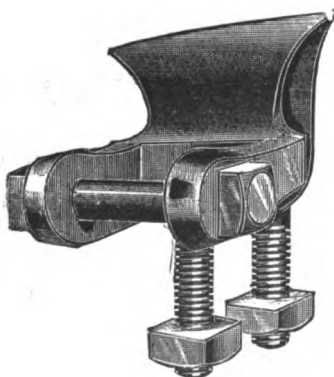

### Skewed Shaft Couplings

**Regular or Oval Patterns  
For High Arched Axles**

Furnished in rights and lefts for any height of arch.  
Oval Axle Clips  $\frac{5}{8}$  or  $\frac{3}{4}$  width to match Oval  
Couplings. Bolts, Clips, Couplings, Carriage  
Hardware and Special Forgings

Catalogue “H” and Prices on Application

**COLUMBUS BOLT WORKS COMPANY**  
COLUMBUS, OHIO

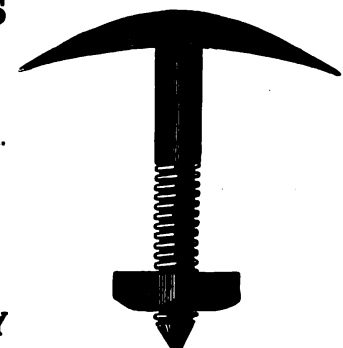

Please mention “The Hub” when you write

# AUTOTRUCK

## Hickory Nut and

BEST QUALITY STOCK  
TOUGH AND HEAVY  
BONE DRY

MANUFACTURED BY  
CAPABLE MECHANICS  
AND MOST  
IMPROVED MACHINERY

WHEELS WHICH ADD TO  
THE LIFE OF YOUR TRUCK

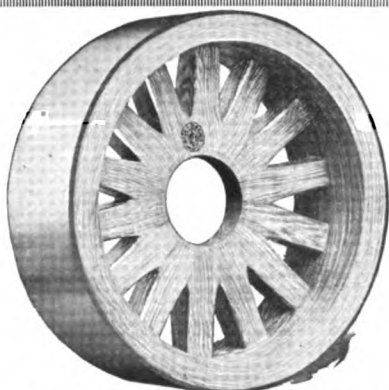

# WHEELS

## Acorn Brands

HORSE-DRAWN  
VEHICLE WHEELS  
ALL STYLES

TRAILER WHEELS:  
SARVEN AND  
ARTILLERY TYPES

HIGH STANDARD OF  
QUALITY AND  
WORKMANSHIP  
MAINTAINED

ST. MARYS, OHIO

CRANE & MacMAHON, Inc.

8 BRIDGE ST., N. Y. CITY

# WILCOX

FINE  
FINISHED  
FORGED

## CARRIAGE HARDWARE AND GEAR IRONS

Write for Prices and Catalog

### The D. Wilcox Mfg. Co.

MECHANICSBURG, PA.

## The WEST Hydraulic Tire Setter

### WILL CUT DOWN EXPENSE

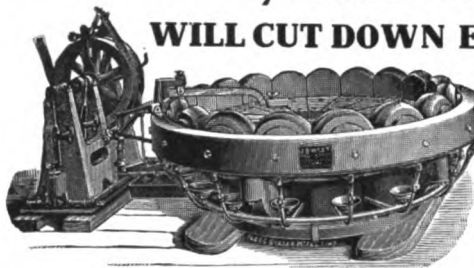

Tires set cold in one minute. This machine saves time—does the work better and quicker, does a way with burned streaks. Only necessary to measure one wheel in a lot. Does not char the rim, and

thus make the tire loosen prematurely. Saves resandpapering of wheels. This machine is now increasing the profits of many manufacturers. Send for catalog and read about it.

WEST TIRE SETTER CO., ROCHESTER, NEW YORK

## PORTER'S BOLT CLIPPERS

"Easy" "New Easy" Allen-Randall



To Cut 5-16, 3-8, 1-2, 5-8, 3-4 Inch.

H. K. PORTER, EVERETT, MASS.

## "Quickwork"

### Sheet Metal Working Machinery

For Automobile and Carriage Bodies, Fenders, Hoods, etc.

## THE QUICKWORK CO.

H. COLLIER SMITH, Pres. and Gen. Mgr. ST. MARYS, O.

## Results Always Follow Advertising in

# THE HUB

## It Pays Others It Should Pay You



ENGINE COOLING

# RADIATORS

FOR PLEASURE CAR AND HEAVY DUTY SERVICE

G & O MFG. CO. - New Haven, Conn.

# MERITAS

---

## LEATHER CLOTH

### **The Leading Leather Substitute for Automobile Manufacturers**

MERITAS Leather Cloth is the accepted quality standard by which other leather substitutes are judged.

Long experience in manufacturing these goods, the largest and most modernly equipped plants (five of them) and a complete knowledge of your automobile top and upholstering requirements enable us to deliver satisfaction with every piece of MERITAS Leather Cloth.

No matter what weight, color, grain or finish you require in a quality leather substitute, you will find it in the MERITAS Leather Cloth line.

Always look on the back of the goods for the MERITAS trademark.

**Samples on Request**

Please state your requirements.

**The Standard Oil Cloth Company**

INCORPORATED

**320 Broadway**

**New York**





# The Hub

First Journal of the Vehicle Industry

Vol. LIX

NEW YORK, MARCH, 1918

No. 12

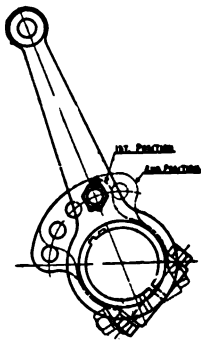
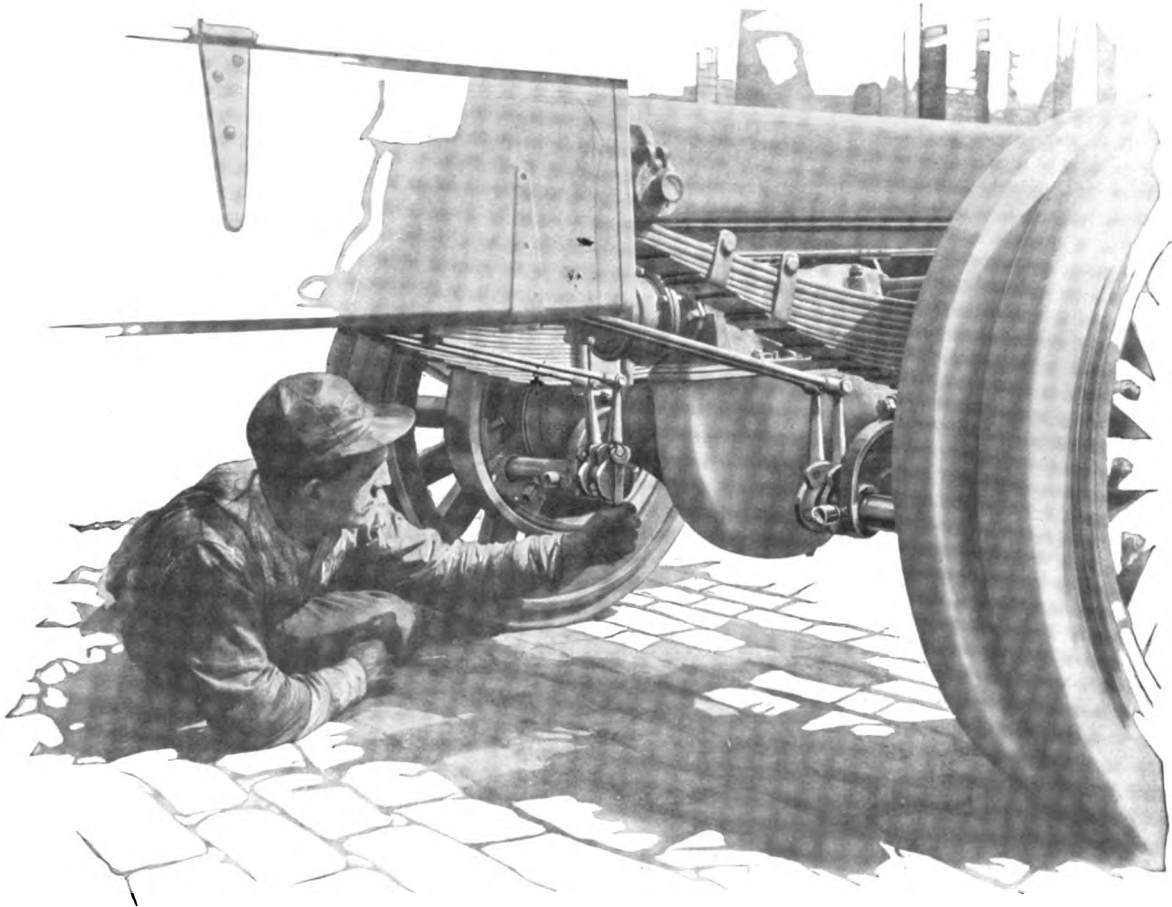

The adjustment is made by a sector attached to the brake pull lever. To tighten up on the brake levers simply take out the bolt which fastens this sector to the lever, and move the hole in the lever backwards one hole on the sector.

## FOR INSTANCE

Note the provision for adjusting the brakes on the Sheldon Worm Gear Semi-floating Rear Axle. It is not necessary to touch the brakes themselves. Just move back the sector to which the brake pull lever is bolted and insert the lever bolt in the next hole. Simple—isn't it? and quick. Minute saving and money saving.

It is this accessibility of parts, this amazing refinement of every feature to best meet the demands of service that one finds the keynote of Sheldon supremacy.

Write for further Sheldon information.

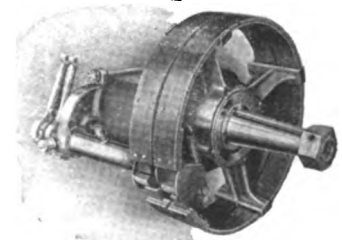

Note accessibility and simplicity of adjustment

# SHELDON



## WORM GEAR AXLES



SHELDON AXLE AND SPRING CO.

Makers of springs and axles for heavy duty service for more than fifty years

WILKES-BARRE, PA.

# MERITAS LEATHER CLOTH

## For Upholstering and Trimming Purposes

Appearance is one thing to consider in buying leather substitutes but quality is even more important.

In MERITAS Leather Cloth you get a good looking but fine wearing material. Every piece is guaranteed by the trade mark of the largest manufacturers of this class of goods.

Whatever weight, color, finish or grain you require in a leather substitute you can find it in the MERITAS Leather Cloth line.

*Write for Samples*

**The Standard Oil Cloth Company**

INCORPORATED

320 Broadway

New York



Leaders in their class for over three-quarters of a century

# FABRICS BRIDGEPORT FABRICS

comprise an elegant assortment of the newest weaves, shades and patterns in automobile upholstery materials

WRITE FOR SAMPLES OF OUR

LIMOUSINE LININGS, CLOTHS, CARPETS, HORSE-HAIR  
CARPETS, CURTAIN SILKS, LACES, SEAT COVER FABRICS

We also supply ROBE RAILS, SPEAKING  
TUBES and TOILET CASES to match upholstery

## BRIDGEPORT COACH LACE CO.

NEW YORK SHOWROOMS, 1765 BROADWAY

BRIDGEPORT, CONN.

**Hartford**  
Universal Joints

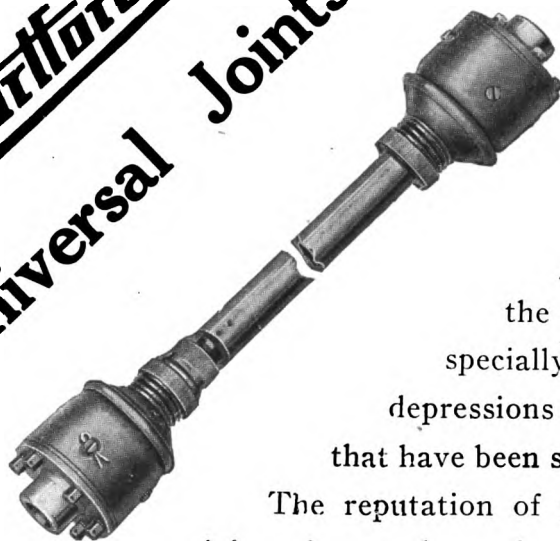

WE are able to offer manufacturers universal joints manufactured by specialists in one of the largest plants in the world.

The wearing surfaces of HARTFORD UNIVERSAL JOINTS are hardened and ground, the grinding being accomplished by a specially devised machine whose use eliminates depressions or elevations so common in steel parts that have been simply reamed.

The reputation of your car demands the best universal joints that can be made, and we have them.

## The Hartford Automobile Parts Co.

Established 1906

Hartford, Conn.

Please mention "The Hub" when you write.

# When a Tire Pump Is Needed You Want the Best Ever Made

An automobile with a flat tire is as help-  
less as an aeroplane with a broken wing

**MAKESHIFT PUMPS  
GIVE ASSURANCE  
UNTIL NEEDED  
MOST—THEN  
THEY FAIL**

**THE BEST  
PUMP MADE—  
GIVES MORE  
ASSURANCE AND  
REAL SERVICE**

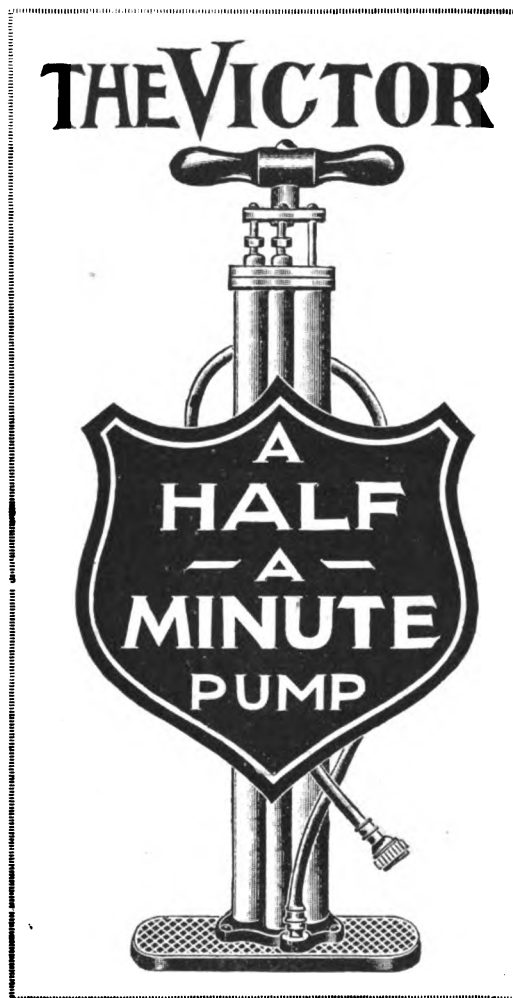

**THE VICTOR**  
Is a triple compressor.  
Its tubes are of seam-  
less brass, of course.  
Its cups of selected  
stock.  
It is simple and quick  
in getting results.

**When needed it can be depended upon, and it  
gives you comfort to know it is in the tool box**

Everywhere in demand

It provides for the greatest need of the motorist

**Judd & Leland Mfg. Co.** Clifton Springs,  
N. Y.

Please mention "The Hub" when you write



# NORTON

## NORTON

### Quick, Accurate, Profitable Crankshaft Grinding

In answering the nation's call for speedy production Norton Grinding Machines are in the forefront.

Automobile Builders as well as manufacturers in other fields were quick to realize the speed, accuracy—and profit, too, resulting from the use of Norton Grinders.

In grinding crankshafts large or small, from roughing to finishing, the Norton saves many valuable minutes—when minutes count for so much.

The illustration shows a small air compressor pump crankshaft both roughed and finished on a Norton. The shaft is about .680 in. in the rough. About .120 in. is removed in the first operation and .008 in. in the second.

About 40 ends or 40 throws per hour are roughed and the same number finished in about the same time.

Our Service Department is always ready to help you with your grinding problems; consult them freely.

## NORTON GRINDING COMPANY

Worcester, Massachusetts

Chicago Store: 11 North Jefferson Street

Vonnegut Machinery Co., Indianapolis, Ind.  
 Robinson, Cary & Sands Co., St. Paul and  
 Duluth, Minn. Manning, Maxwell Moore,  
 Inc., St. Louis, Mo. Henry Prentiss Co.,  
 New York, N. Y.; Boston, Mass.; Buffalo,  
 N. Y.; Rochester, N. Y.; Syracuse, N. Y.;  
 Scranton, Pa. The Motch & Merryweather  
 Machinery Co., Cleveland, O.; Detroit, Mich.;  
 Pittsburgh, Pa.; Cincinnati, O. Eccles &  
 Smith Co., San Francisco, Cal.; Los Angeles,  
 Cal.; Portland, Ore. The Canadian Fair-

banks-Morse Co., Ltd., Montreal, Que.; To-  
 ronto, Ont.; Vancouver, B. C. C. T. Patter-  
 son Co., Ltd., New Orleans, La. Kemp  
 Machinery Co., Baltimore, Md. W. E. Ship-  
 ley Machinery Co., Philadelphia, Pa. English  
 Tool & Supply Co., Kansas City, Mo. Alfred  
 Herbert, Ltd., Coventry, Eng.; Paris, France;  
 Milan, Italy. Post Van der Burg & Co.,  
 Rotterdam, Holland. The F. W. Horne Co.,  
 Tokio, Japan. Iznosskoff & Co., Petrograd,  
 Moscow and Ekaterinburg.



# CENTURY

"C. T. V. No. 5"

## Tungsten Valve Steel

Regular Analysis or to Special Analysis for  
TOUGHNESS RIGIDITY HIGH HEAT RESISTANCE

### THE CENTURY STEEL CO. OF AMERICA

Manufacturers of High-Grade Crucible Steels

General Office and Works:  
POUGHKEEPSIE, N. Y.

CHICAGO SALES OFFICE:  
E. P. Bartlett & Co., 15 N. Jefferson Street  
PHILADELPHIA SALES OFFICE:  
Century Steel Co. of America, Real Estate Trust Bldg.

CLEVELAND SALES OFFICE:  
J. E. Rawson, Rose Building  
NEW YORK SALES OFFICE:  
Century Steel Co. of America, 120 Broadway



## Superbar Tires

"Service Tires"

Made of high grade fabric and best grades of pure rubber to meet the demand of those who seek a good Standard Quality Tire giving maximum amount of service for money invested.

Built by HAND throughout.

SUPERBAR Tires are the result of many years of scientific experimenting and combine quality of material, skill in workmanship and a maximum of road resistance.

Adjusted on 3,500-mile basis. Ford sizes, 4,500-mile basis.

Splendid agency opportunities are available; particulars on request.

### Century-Plainfield Tire Co.

Plainfield, N. J.

Century-Plainfield Tire Company, a subsidiary of the Rubber Metals Corporation, exclusive manufacturers of the Rimco Rubber Products by the Elchemco process

Please mention "The Hub" when you write

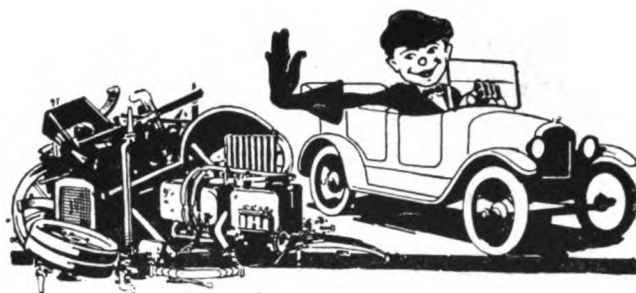

## Prevent Friction From Sending Your Car to the Scrap Heap

Friction will slowly but surely send a car to the scrap heap. In spite of lubricating oils and greases, it continually wears away the bearings. Every bearing is full of microscopic holes and pin points which will, if left alone, cause ruinous friction.

Dixon's Selected Flake Graphite is the only lubricant that will fill up these holes and build up around these pin points a smooth, oily veneer that grows finer and more smooth with use and wear. With this rare form of flake as a basis we have produced a line of graphite lubricants specially designed for every separate part of the car.

Try Dixon's Transmission and Differential Grease No. 677 and see what a difference it will make in mileage and smoothness of running.

Write for Booklet No. 123-G, "Help You Help Your Car."

**DIXON'S**  
GRAPHITE  
Automobile  
**LUBRICANTS**

Made in Jersey City, N. J., by the

**Joseph Dixon Crucible Company**

Established 1827



Please mention The Hub when you write

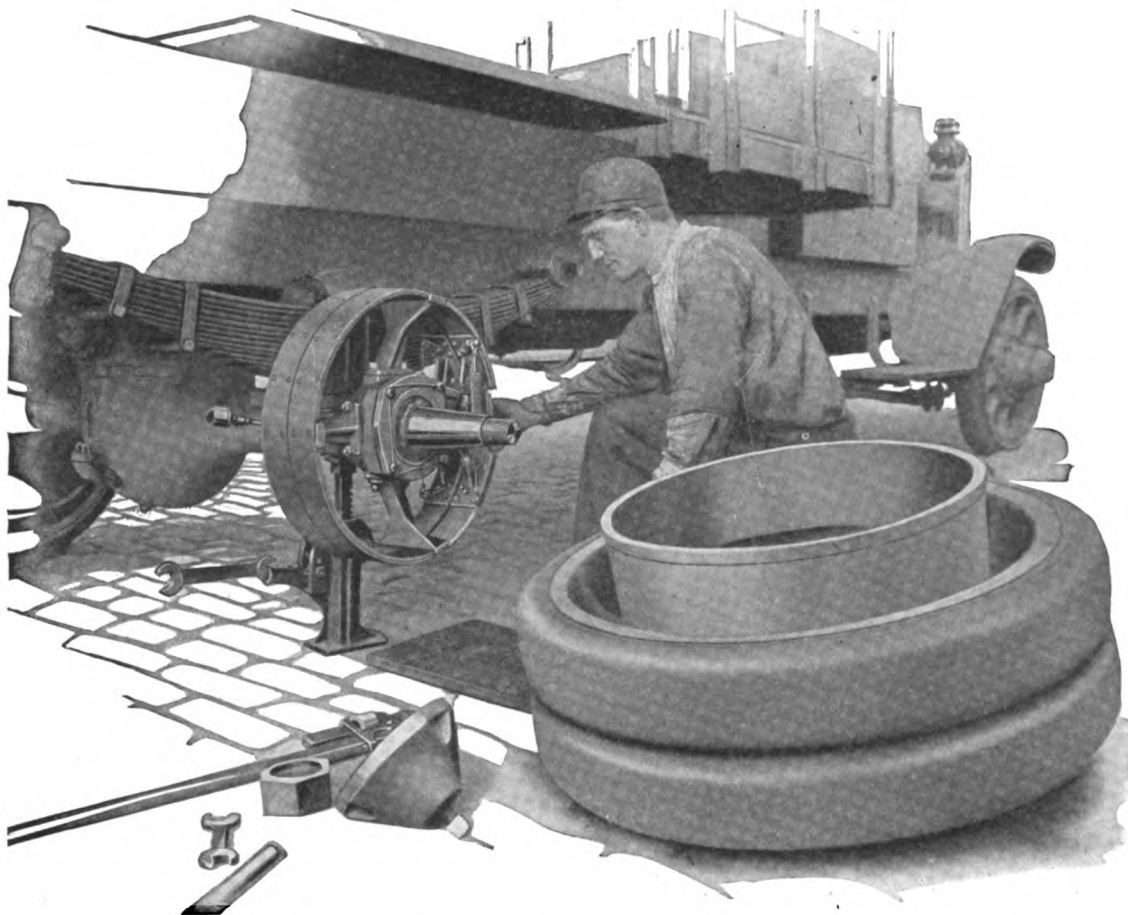

## UNDER THE HUB-CAP

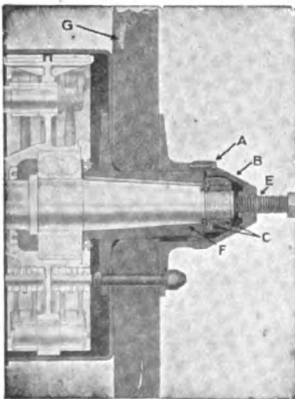

Ready demountability of Sheldon wheel hub. Remove parts A, B, and C, replace B (hub cap), insert E (set screw), and screw against shaft. Tap back of wheel G till it comes loose.

If it becomes necessary to take a wheel off a Sheldon Worm Gear Axle you will be surprised to find how easily and quickly it can be done.

Then look at the sturdy mechanism revealed. The tapered drive shaft which facilitates the removing of the wheel, the double internal expanding brakes with generous bearing surfaces, the enclosed bearings—away from dirt and grit—every part giving evidence of the high engineering skill and master workmanship which have made Sheldon Worm Gear Semi-floating Rear Axles the standard of truck axles.

Sheldon Worm Gear Axles are built to the triple ideal of strength, accessibility and service.

Write for detailed information.



Gauging bearing seats on front axle spindle. These surfaces are held to limits of 0.0005" for outer bearings and 0.00010" for inner bearing seat.

# SHELDON

 WORM GEAR AXLES 

SHELDON AXLE & SPRING CO.

Makers of springs and axles for heavy duty service for more than fifty years

WILKES-BARRE, PA.

# The Hub

Vol. LIX

NEW YORK, MARCH, 1918

No. 12

Published Monthly by

## THE TRADE NEWS PUBLISHING CO. OF N. Y.

PAUL MORSE RICHARDS, *President* G. A. TANNER, *Secretary and Treasurer*

EDISON BUILDING, COR. ELM AND DUANE STS., NEW YORK

THE HUB, a monthly authoritative journal on all subjects pertaining to the vehicle industry from its engineering and construction viewpoints. It publishes information of live interest to manufacturers of motor vehicles, trailers, carriages, wagons, the accessory trades, repair shops and garages.

Subscription price for the United States, Mexico, Cuba, Porto Rico, Guam, the Philippines, and the Hawaiian Islands, \$2.00; Canada, \$2.50; payable strictly in advance. Single copies, 25 cents. Remittances at risk of subscriber, unless by registered letter, or by draft, check, express or post-office order, payable to the order of THE TRADE NEWS PUBLISHING CO.

For advertising rates apply to the publishers. Advertisements must be acceptable to publishers. Copy for new advertisements must be received by the 25th of the preceding month. All communications must be accompanied by the full name and address of writer.

Entered in the New York Post Office as Second-class Matter

## Progress of War Savings Campaign

The receipts of the Treasury Department through the sale of War-Savings and Thrift Stamps through February have equaled \$75,000,000. The receipts for the month of February totaled \$41,000,000, as against \$37,000,000 received through the War-Savings campaign in England for the same period, despite the fact that the campaign has been running there for over two years.

The receipts are coming in to the Treasury Department at the rate of about \$2,000,000 a day. In other words, the receipts in this country, after three months, are already running at the same rate which England has reached after two years.

The total receipts in England up to January 26, 1918, were \$550,000,000. At the rate at which the campaign is running here we shall reach this total inside of the year allowed by Congress for the present campaign. If the rate continues to increase as it has been increasing during the past month there should be no difficulty in attaining the \$2,000,000,000 goal set by Congress for the year's campaign.

It should be borne in mind that this money represents the residue after two intensive Liberty Loan drives and after the constant appeals for charity which have been made to the people of this country since the beginning of the war. The present rate of return from the sale of stamps is equal to the entire daily cost of running the government ten years ago. It is in excess of the highest rate of growth ever reached by the savings banks in this country. It is double the total daily receipts of the post office department and double the customs receipts before the war. It is in excess of the total interest payments to

holders of railroad bonds, and in excess of the average new capital expenditures for railroad development.

If the campaign attains the goal set, it will cover the entire cost of the government's ship building program for the year. Already the government is receiving from the buyers of War-Savings Stamps daily enough money to build more than 10,000 tons of shipping. It has received to date funds for the building of 420,000 tons or 84 ships of 5,000 tons each.

The first of May will be observed throughout the United States as Thrift Stamp Day and it is planned to make a drive on that occasion that will score an overwhelming success. For particulars see full page announcement in the advertising pages of this issue of *Harness*.

## Value of Auto Exports

What the export trade of the automobile industry means to the prosperity of the American workingman and to the many lines of trade on which the industry draws for supplies of materials is shown by the fact that exports of motor cars and parts, engines and tires to foreign countries amounted to a total of \$138,043,075 last year.

To this should be added more than \$3,300,000 worth of motor vehicles exported last year to Alaska, Hawaii and Porto Rico—non-contiguous territory of the United States—and also \$587,000 worth of automobile parts, not including engines and tires, also exported to those American possessions.

The exports of passenger automobiles and motor trucks exceeded in value by 50 per cent last year's exports of railway locomotives and passenger and freight cars, or of all electrical locomotives, machinery and appliances, were 11 times as great as the combined exports of carriages, wagons, bicycles, motorcycles, airplanes, traction engines and caterpillar tractors, and nearly three times as great as exports of all agricultural machinery.

## Waste of Coal

Two hundred and fifty million dollars a year is going to waste through improper operating methods in boiler plants. By the introduction of proper methods, ten per cent of all the coal now burned for steam-raising purposes might be saved. Such a saving would release for other service freight car space equal to the total coal-carrying capacity of the Pennsylvania Railroad east of Pittsburgh. The above statements were made by David Moffat Myers in a paper read at the annual meeting of the American Society of Mechanical Engineers. Investigations made in one steel mill, he also declared, showed that it was possi-

ble to save in the boiler furnaces of that mill alone, 40,000 tons of coal yearly. Yet the plant in question was comparatively modern in its methods. There are many more extreme cases.

In one hand-fired plant the steam evaporation was raised from six to nine pounds per pound of coal by simply giving a few days' instructions to the employes. The saving or wasting of one-quarter of the coal consumption at an industrial plant depends entirely on the efficiency of its operating management. Yet, under present conditions, a plant operated carelessly at an efficiency of from 40 to 50 per cent receives the same consideration in the delivery of coal as a plant having an efficiency of from 70 to 75 per cent.

Fuel waste in power plants may be prevented by enforcing upon coal consumers measures of economy, or by inculcating patriotism as a motive and emphasizing the advantages to be derived from coal saving. Coal users will probably make many objections to the first plan; yet, were it once put into effect, most of them would doubtless realize its pecuniary value to themselves.

By a more efficient use of their equipment, last May the railroads of the country carried 29,522,870,109 tons one mile, an increase of 16.1 per cent over May, 1916. In 1917 the average daily run of the locomotives was 71.3 miles, against 65.5 miles in 1916, and the average daily mileage of freight cars was raised from 28.3 to 29.6 miles.

The War Department has announced that hereafter the metric system of measurement will be employed as the standard for all artillery, machine guns, and maps used by the American Overseas Forces.

### Road Building Policy

Secretary Houston, of the Department of Agriculture, in a communication to the American Association of State Highway Officials, has set forth squarely the policy which he thinks should be followed in highway construction during the war. Secretary Houston says:

"So far as it is practicable to do so, this department will urge the maintenance of the highways already constructed; the construction and completion of those highways which are vitally important because of their bearing upon the war situation or for the movement of commodities; the postponement of all highway construction relatively less essential or not based upon important military or economic needs. The department is preparing to suggest to the state highway departments the preparation of a schedule of work for the federal aid projects for 1918 in line with this policy."

In carrying out the policy thus announced there has been sent out by the Office of Public Roads, of the Department of Agriculture, schedule forms on which the states are requested to set forth their proposed federal aid work for the 1918 working season. These schedules call for a description of each road, the character, quantity and rail haul of the materials to be used, the probable cost, the amount of federal funds desired, the specific purpose of the improvement, its bearing upon the war situation, and what effect a delay of the work until 1919 or later would have. With the information thus assembled and classified, an efficient road construction program is assured. While it is impossible to make any definite statement re-

garding the transportation of road materials, the expectations are that the transportation situation will be improved and that the shipment of such materials for essential projects can be made.

Road construction and maintenance in the United States involve an annual expenditure of some \$300,000,000, and there is scarcely a section of the country that is not seriously affected by a marked disturbance in road work.

### How to Pay Your Income Tax

Pay your income tax, if possible, by check, money order, or draft. This is the urgent request of the Bureau of Internal Revenue.

More than 6,000,000 persons this year will pay an income tax. The total to be collected under the war revenue act of October 3, 1917, in individual income taxes alone is \$666,000,000. The vast majority of these payments will be small amounts. If paid as requested it will avoid the necessity for the issuance of a receipt, and save much time and labor.

Taxes paid to deputies who are visiting every county in the United States to assist taxpayers in making out their returns are sent to the collector of internal revenue of the district in which the taxes are collected. Checks, money orders, or drafts can be handled without difficulty. Cash has to be sent by registered mail or by insured express.

In the conduct of the war Uncle Sam is beset with many difficulties. You can render one of his innumerable tasks less difficult by paying your income tax promptly, and by check, money order, or draft.—From the Bureau of Internal Revenue.

### Four-Passenger Sedan Landaulet

Working drawing on opposite page

The design represents a luxurious four-passenger sedan landaulet, mounted on 3-35 Packard chassis.

The wheelbase is 136 in., and nearly 106 in. of this length are devoted to the body space. To make the appearance of the car more distinctive the radiator is raised 2 in. and the dash is 28 in. above the chassis, this being also the height of the body sides. Other dimensions can be obtained from the drawings which are made to scale. The hood lines are taken from the regular Packard radiator and, while carried back to the cowl, the form becomes round; in other words the square form of the radiator changes about in the middle of the dash. The body is equipped with V front, and behind the driver's seat is a separation with window which can be lowered all the way down. To give easy entrance through the front doors, the seat cushions are hinged. The upper leather section folds back when the weather permits, and when collapsed there is none of the bulky appearance so objectionable when heavy sections are folded back in an attempt to convert a closed car into one which has the advantages of the open style.

### Weights of Water and Fuel

The weight of a gallon of water, pure, at 62 deg. F., the standard figure, is 8.3356 pounds. The usual number taken is 8.33, since all water is not pure, nor can it always be had at that temperature. In round figures, gasoline weighs about 7 pounds, and kerosene 7.9. This makes the former 16 and the latter 5 per cent lighter than water.



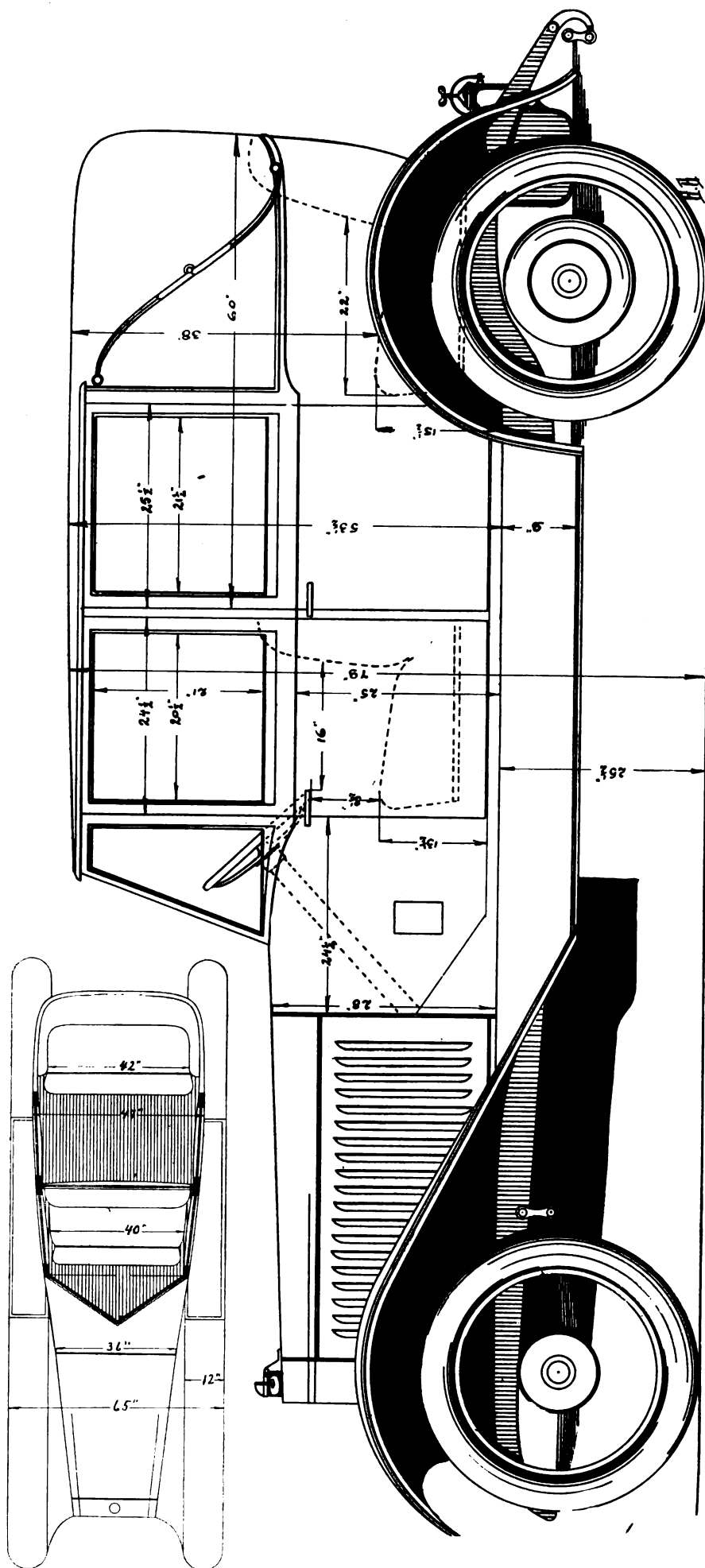

FOUR-PASSENGER SEDAN LANDAULET

Description on opposite page

## Making Over a Losing Department\*

By Charles J. George

Five years ago we started business with a total of three employes. Now we number 63 and are still growing. As our growth was fast from the start, we devoted very little study to the finer details of the business. We knew that our profits came from the sales of automobiles and supplies and that our repair shop was absorbing some of these profits. We counted our loss in the repair department as a necessary expense to the promotion of sales and so tried to forget it. But month after month this loss increased, and after an investigation we put in our present shop system. Now, instead of losing money, we are making a substantial profit on our repair department.

In planning our system "red tape" was conscientiously avoided and only records giving practical and useful information were adopted.

When a customer drives up to our place of business to have his car repaired he is met by our service man, who inspects not only that part of the car called to his attention, but other parts as well. Although an accommodation to the customer, this results in considerable additional business.

### Repair Order Follows Inspection

After the inspection a shop repair order is made out. This form is composed of three copies printed on both sides. The first two copies are alike on both front and back. The third sheet is made of cardboard. The service man uses carbon and writes the order in triplicate. The repair operations are written separately, with the proper labor charge after each one. In this way the customer knows in advance how much he must pay for the labor.

A claim check and jogger card are made out together. The claim check is given to the customer; and the jogger card, with the original and duplicate sheets of the repair order, is sent to the cashier in the office, who pins the two sheets together and holds them in numerical order. The cardboard copy is sent with the car to the repair shop, where it is turned over to the shop foreman, who gives it to the workman put on the job. The workman uses the back of this card to record the time he spends on each operation.

A daily time report card for each workman is kept by the shop clerk. Workmen are required to report whenever they change jobs. This form is kept primarily to distinguish between profitable and unprofitable labor.

Material used on repair jobs can be secured only by presenting a requisition to the clerk in charge of the stockroom. The clerk here, after he delivers the material to the workman, writes the prices opposite the names of the articles on the requisition, puts his number in the space provided and sends the requisition to the cashier to be posted to the original and duplicate of the repair order.

### Getting Job Done on Time

Shortly before the time a job is promised the cashier refers to her jogger cards. These are filed before her according to the time the jobs are promised. She calls up the repair shop and asks about the progress of that particular job. We have found that this attention from someone not connected with the repair department is a big help in getting the jobs completed at the promised time.

When a job is finished the workman reports to the shop

foreman. The latter inspects the car and turns the repair order card in to the tool room. The shop clerk stamps the card "finished" and sends it by carrier to the cashier. She totals the labor charges, removes the original and duplicate copies from the file, totals the material charges, enters the labor charges, and makes a grand total. The three copies of the shop repair order are then held together until the customer calls for his car. When he arrives and pays his bill the duplicate of the shop repair order is given as a receipt. The cashier then telephones the shop to send the car, which is delivered upon presentation of the receipt.

Each shop workman has assigned to him a box containing the tools he is likely to need. These boxes are turned in at the tool room every night. If a special tool not included in the assortment is needed, a workman may get it from the tool room by giving in exchange a small brass check stamped with his number. This check is hung on a hook in the bin from which the tool was removed and is given back to the workman when the tool is returned. We keep a perpetual inventory of all the tools. This enables us to keep an accurate check on all our tools and saves considerable time and money.

Costs are figured each morning on all the repair jobs turned out the day before. We use the percentage on wages method. We have established a regular scale of repair prices and tell each customer before the job is started the amount he will be charged for labor. We have found this plan particularly advantageous. Our shop foreman and also the workmen know that if they do their work quicker the profits will be greater. They can see where their efforts will be of direct aid to the company. However, when there is a fixed charge per hour for labor, the workman cannot see any great advantage in hurrying, and naturally feels that no matter how much he hurries the profits will be no greater. He simply feels that the sooner the job is done the less the customer will have to pay. This, of course, makes the company's profit less in the long run.

### Workmen Try to Keep Jobs Moving

Each day after the shop repair order cards have been totaled, the cost figured and the profit or loss shown on them, they are sent to the shop foreman, who uses them in reviewing the work of the day before. He can immediately locate any lagging on the part of the workmen. The workmen know this and when they are forced, through no fault of their own, to spend an unusually long time on a job, they generally explain the circumstances to the foreman even before he has an opportunity to see the record of their time and ask for an explanation.

By watching the workman's time and the profits on the jobs the foreman knows how to distribute work among the men to the best advantage. He knows the kind of work for which each man is best fitted. The result is our workmen have become specialists in this work and we get the maximum earning power out of each man.

We use several plans to keep the men interested in the business. A year ago we put in a profit-sharing plan. The results so far have been very satisfactory. Each man receives only a regular weekly salary equal to the amount ordinarily paid for his class of work until the end of the year. If the records show that he has personally interested himself in the business and exerted extra efforts in his work he is paid a certain share of the annual profits.

The amount of the share is determined by the extent of

\*Reprinted from System.

his extra efforts and the amount of profits earned in his department. As each shop man comes under the direct supervision of two people, the shop foreman and the captain of his service shift, it is easy for us to tell who is doing the best work.

One of the duties of both the service shift captain and the shop foreman is to make a study of the individuals under their supervision. Every month they turn in a detailed report of each workman, making note of the man's progress, the spirit in which he does his work, his good qualities, his bad qualities, and any other facts that might be used for the betterment of the individual. We consider these reports very valuable, particularly because each workman is studied by two department heads and from two different points of view. We are given a chance to understand our men, to try and correct their faults, and to advance them judiciously. The service shift captain often helps the foreman with a man who is giving trouble. Not being connected with the shop and having but a few men under him, he can talk freely.

Another plan which has been of considerable value to us is our "shop efficiency contest." Every month a clean sheet containing the names of the shop workmen is posted on the bulletin board. When a workman violates one of the contest rules a certain number of black marks—the number varies with the seriousness of the error—is placed after his name.

Every man completing the contest period without having any black marks receives a gold badge—or a gold bar to attach to his badge if he has already won a badge. If no one has a perfect score a silver badge is awarded to the man having the fewest black marks, providing the number does not exceed five. Any man receiving more than ten black marks during the contest period is suspended for a time.

**Black Marks Are Given For**

1. Failure to properly check in at tool room or on a repair tag.
2. Not putting box in tool room at night (box must be in 30 minutes after man checks off from work).
3. Not turning checks in to tool room at night.
4. Not turning borrowed tools in at tool room at night.
5. Leaving tool boxes out at night.
6. Using another man's tools without the foreman's permission (this is permissible, however, if the man whose tools you are using is working on the same job).
7. Working on a car not properly lined up.
8. Not putting clothes on rack properly or failure to button curtains when finished with rack.
9. Leaving trash on job after checking off (last man checking off is responsible).
10. Throwing or leaving trash on floor at any time.
11. Losing repair tag.
12. Slighting work on job.
13. Checking in late morning or noon.
14. Cursing or using other objectionable language.
15. Wrongly numbering a requisition.

The workmen show a great interest in these contests and the monthly average of black marks per man has steadily decreased. The men became more careful, not only in those things for which they were liable to receive black marks, but in all their work.

With the idea of keeping up the enthusiasm of the shop workmen, as well as the others of the organization, a meeting is held once a week. "Ginger up" talks are given

by the department heads and many of the shop men make short talks. Enthusiasm prevails from start to finish.

Co-operation of our employes, coupled with records that show us leaks, is responsible for our success. We are now being forced to double our present quarters.

**Civilians Wanted for Ordnance Department  
Special Training for Those Not Experts**

Men having a high school education, some shop training and the natural ability to adapt themselves to new work, may qualify for a government appointment in which, under government instructors, they will receive the necessary training for the positions described below. Those who have the required technical training will be placed and advanced as quickly as their ability justifies.

**Which One of These Jobs Suits You?**

- Inspectors and assistant inspectors, field artillery ammunition steel.
- Inspectors artillery ammunition, cartridge cases, assembling, loading, forging, primers, detonators, shell and shrapnel machining.
- Ballistic inspectors.
- Metallurgical chemists and assistants.
- Inspectors, powder and explosives.
- Inspectors, cannon, forging operations.
- Inspectors, gun carriages and parts.
- Inspectors, gun fire control instruments.
- Assistant inspectors, motor vehicles and artillery wheels.
- Engineers and assistant engineers, for tests of ordnance materials.
- Inspectors, ammunition packing boxes.
- Machinists, accustomed to work to 1000's of inch.

Send in your own application and urge your associates who may be qualified to do so. These positions are under civil service regulations, but applicants will not be required to report for examination at any place. Applicant will be rated in accordance with education and general experience. No applications will be accepted from persons already in the government service unless accompanied by the written assent of the head of the concern by which the applicant is employed. Papers will be rated promptly and certification made with least possible delay. Apply or write for further information to C. V. Meserole, special representative of the Ordnance Dept., U. S. A., Room 800, 79 Wall street, New York City.

**Ford Car Price Increase**

The Ford Motor Co. has increased the price of its cars \$90 and its chassis \$75. The price of the truck chassis remains unchanged. Frank Klingensmith, treasurer of the Ford company, ascribed the increase to the rising cost of materials. It is likely that the reduced output of the Ford company also has had an important bearing, the present production being but 1,500 cars a day as against 3,000 a short time ago.

**Ford Prices**

Model	Old Price	New Price	Increase
Touring .....	\$360	\$450	\$90
Roadster .....	345	435	90
Chassis .....	325	400	75
Truck chassis .....	600	600	..



**SPORTING ENCLOSED DRIVE BREWSTER**  
Body and chassis by Brewster & Co., New York

This car was exhibited at the New York Salon and was fully described on page 19 in the January issue of *The Hub*

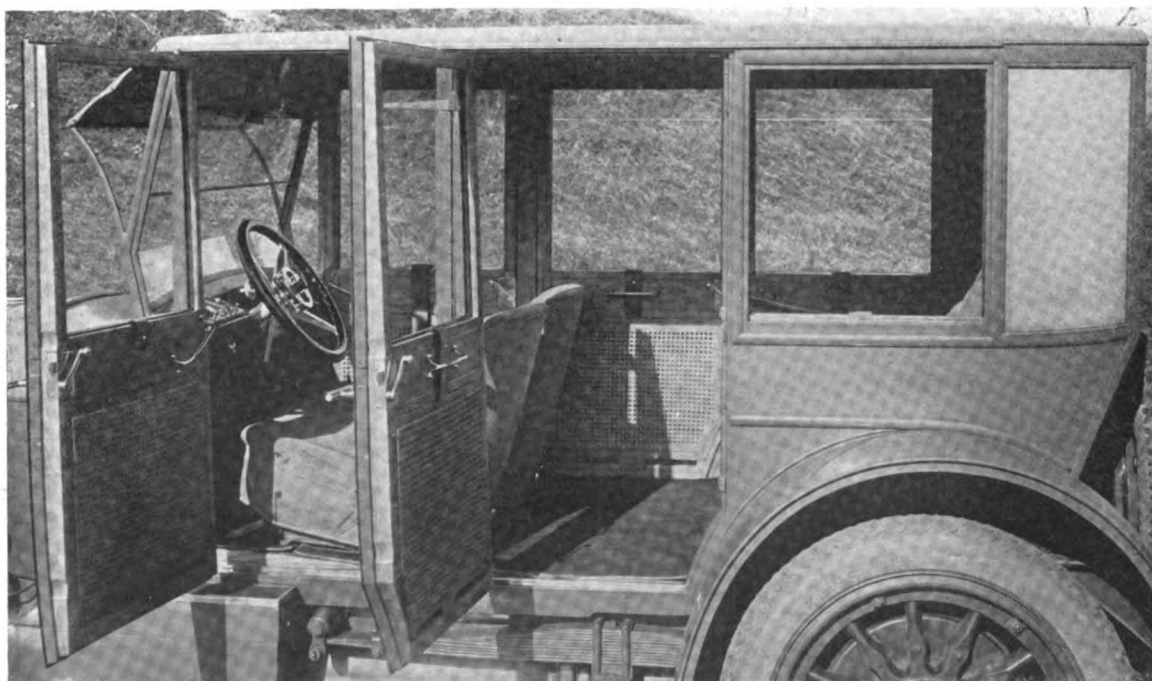

**INTERIOR VIEW OF SPORTING ENCLOSED DRIVE BREWSTER**

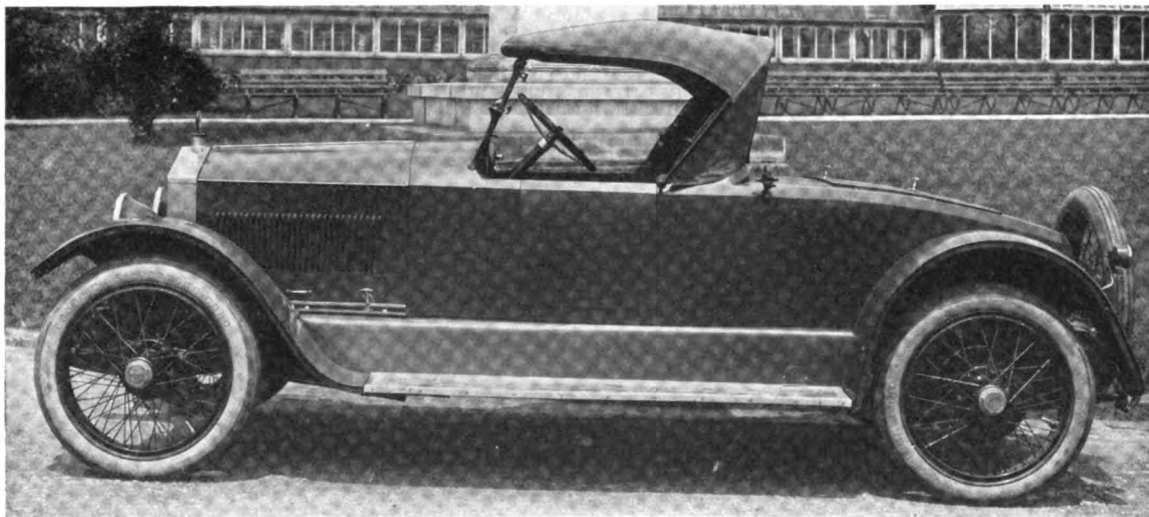

**MURRAY ROADSTER**

Body by Theodor Kundtz Co., Cleveland. Mounted on Murray chassis

Shown at New York Salon. The cubist car body, mounted on Murray chassis, shown on page 17 in the January issue of *The Hub*, was built by the Theodor Kundtz Co., as well as the body of the White touring car shown on the same page and credited to Rubay Co.

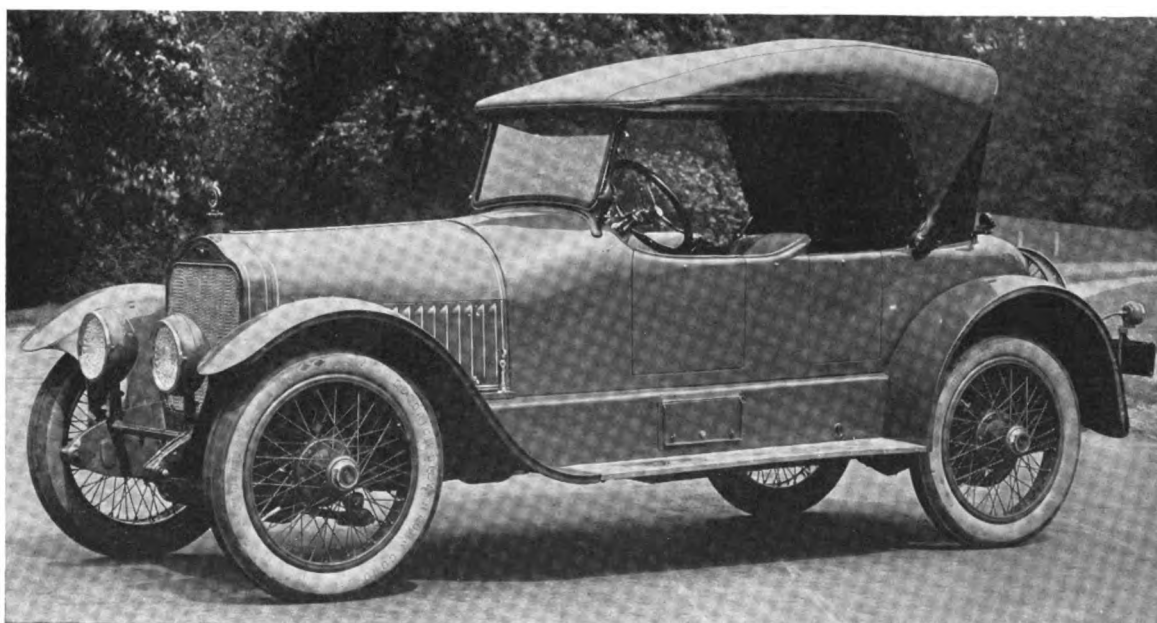

**WHITE FOUR PASSENGER RUNABOUT**

Shown at the New York Salon



## Automobile Exports Largest in History

More passenger automobiles were exported from the United States during the year 1917 than in any previous year, despite import prohibitions by the countries that were formerly the largest buyers of American motor cars, and scarcity of ocean cargo space, with consequent greatly increased shipping rates. The report of the Department of Commerce shows that there were exported during the 12 months ended December 31 last, 65,792 passenger cars, valued at \$51,982,966, wholesale. This is almost double the value of the combined exports of passenger and commercial cars in 1913 or 1914, and an increase of 48 per cent in exports of passenger automobiles over 1915 and nearly 19 per cent over 1916.

These figures are significant of the appreciation of the utility of the American motor car in all of the countries of the world when it is remembered that imports of automobiles have been prohibited during the past year in England, France, Italy and India, that Germany, Austria, Bulgaria and Turkey have been dropped from our trading list, that shipments have been almost impossible to European Russia, that tires could not be exported to the Scandinavian countries and that Australia prohibited the importation of automobile bodies.

Tremendous changes have occurred in the motor car market of the world in the last two years. Whereas exports of passenger automobiles to the United Kingdom decreased from 14,787, valued at \$11,483,675, in 1915, to only 1,349, valued at \$1,978,948, in 1917, the exports to Chile increased from 497, worth \$318,913, to 3,937, worth \$3,481,061, or eleven fold, in the same period. During the same two years exports to Russia dropped from a total value of \$5,762,019 to \$1,761,388, while passenger car exports to Canada increased from \$4,304,718 to \$12,401,705.

The high tide of sales of army trucks to our Allies was reached in 1915, when 22,094, worth \$59,839,303, were shipped. Last year the number fell to 14,347, worth \$36,364,773. Some, at least, of this decrease was made up by shipments of trucks to France for the American expeditionary force, but these do not appear in the official report of exports.

Last year the United Kingdom, France and Russia bought 11,136 trucks, valued at \$31,495,087, while all the other foreign countries combined took only 3,211, worth \$4,869,686.

Canada is by far the best customer for American automobiles, taking nearly four times as many as any other country. Australia ranks next with more than \$3,500,000 worth; Chile is a close third, and Argentina, Cuba, British South Africa, the Dutch East Indies and New Zealand each purchased cars to the value of between \$2,000,000 and \$3,000,000.

Remarkable showing is made by the smaller countries not considered of sufficient importance to be given separately in the monthly summary of exports and therefore combined under the item "other countries." Their passenger car imports increased five fold in the two years, from a value of \$2,567,305 in 1915, to \$12,244,798 last year.

What the export trade of the automobile industry means to the prosperity of the American working man and to the many lines of trade on which the industry draws for supplies of material is shown by the fact that exports of motor cars and parts, engines and tires to foreign countries amounted to a total of \$138,043,075 last year.

To this should be added more than \$3,300,000 worth of motor vehicles exported last year to Alaska, Hawaii and Porto Rico—non-contiguous territory of the United States—and also \$587,000 worth of automobile parts, not including engines and tires, also exported to those American possessions.

The exports of passenger automobiles and motor trucks exceeded in value by 50 per cent last year's exports of railway locomotives and passenger and freight cars or of all electrical locomotives, machinery and appliances, were eleven times as great as the combined exports of carriages, wagons, bicycles, motorcycles, airplanes, traction engines and caterpillar tractors, and nearly three times as great as exports of all agricultural machinery.

## Rushing Work on Ford Plants

More than 6,000 men are rushing toward completion the Ford Motor Co.'s blast furnace and shipyard projects in the down river district of Detroit—projects which will eventually involve \$20,000,000 and employ from 20,000 to 30,000 men. Temporary buildings are being put up, the River Rouge being dredged and straightened, and the first steel work of the permanent factory structures being erected.

The blast furnace plant will cover 350 acres and will have four stacks with a byproduct coke plant. It is planned to have two furnaces in operation by next year. Among the buildings which will be constructed will be an administration building, 175 x 175 ft.; laboratory, 175 x 175 ft.; byproduct plant, 1,000 x 1,000 ft.; power house, 300 x 440 ft.; machine shop, 200 x 1,000 ft.; foundry, 275 x 1,000 ft., and a cleaning shop, 100 x 1,000 ft. The storage yards, two for ore and two for coal, will be 500 x 1,530 ft.

The byproduct plant will be operated and owned by the Semet-Solvay Co., Detroit. The Ford company has entered into an agreement with the Semet-Solvay Co. whereby the latter will occupy a part of the blast furnace property, reducing the coal to coke and taking out all of the byproducts, also furnishing the Ford factory with gas.

The entire construction plan is in the hands of W. B. Mayo, chief engineer of the Ford Motor Co. G. R. Thompson, superintendent of construction at the Ford Motor Co., is directing the construction work on the site. J. W. Gray, resident engineer for Julian Kennedy, the Pittsburgh engineer, is supervising the installation of the four blast furnaces.

## Sechler's Office Wrecked by Freight Car

The front wall of the D. M. Sechler carriage works, in Moline, was badly damaged on Sunday morning, March 2, and the office building partially wrecked, when a Rock Island switch engine pushed a freight car through the wall. The wall for a width of about 60 feet was so badly damaged that it will have to be torn down and be rebuilt, the office fixtures in the building were wrecked and broken and scattered about, and the car that crashed into the building was wrecked. A force of men was put to work at once to repair the damage.

## Detroit Turned Out 23,229 Trucks

Detroit plants produced 23,229 trucks in 1917 at an approximate market value of \$45,462,000. The total production of Detroit and Flint, Lansing and Alma aggregated an approximate market value of \$60,962,000.

## Automobile Springs

### Notes on Principal Types, Manufacture and Testing

By Chester L. Lucas\*

The use of leaf springs for horse-drawn vehicles dates back to 1750, but it remained for the motor car industry to put the manufacture of vehicle springs upon a scientific basis. A great deal of credit for this advance is due the Springs Division of the Society of Automobile Engineers, who, of course, have received the co-operation of American spring manufacturers.

Fig. 1 shows the five most important types of automobile springs in common use, though there are many variations in forming and mounting. These are the full elliptic, semi-elliptic, three-quarter elliptic, cantilever, and platform types. Each type has an action different from the others and is used in various front and rear combinations by different automobile builders, the practice varying with the demands of the particular car in question.

Full Elliptic—This type of spring is probably the most flexible of the standard types, but it is more susceptible to

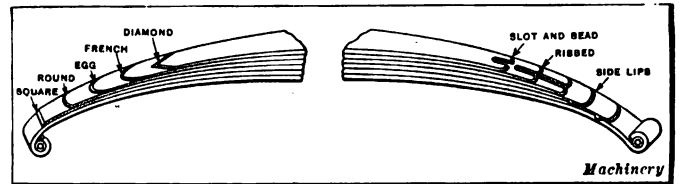

Fig. 3—Varieties of spring plate ends in common use

It is more largely used in both front and rear installations than any other type of spring. Among the most common of the cars using it are the Pierce-Arrow and the Chalmers.

Three-quarter Elliptic—This type is a compromise design that is more flexible than the semi-elliptic and still has the side sway well controlled. Almost invariably, this spring has a scroll member at the top, but at times it is used without the scroll. This is a popular spring for rear installations in combination with the semi-elliptic at the front. Among the cars using this type of spring are the Dodge, Studebaker and Oldsmobile.

Cantilever—The cantilever spring is growing in popularity, particularly for rear installations. It permits little

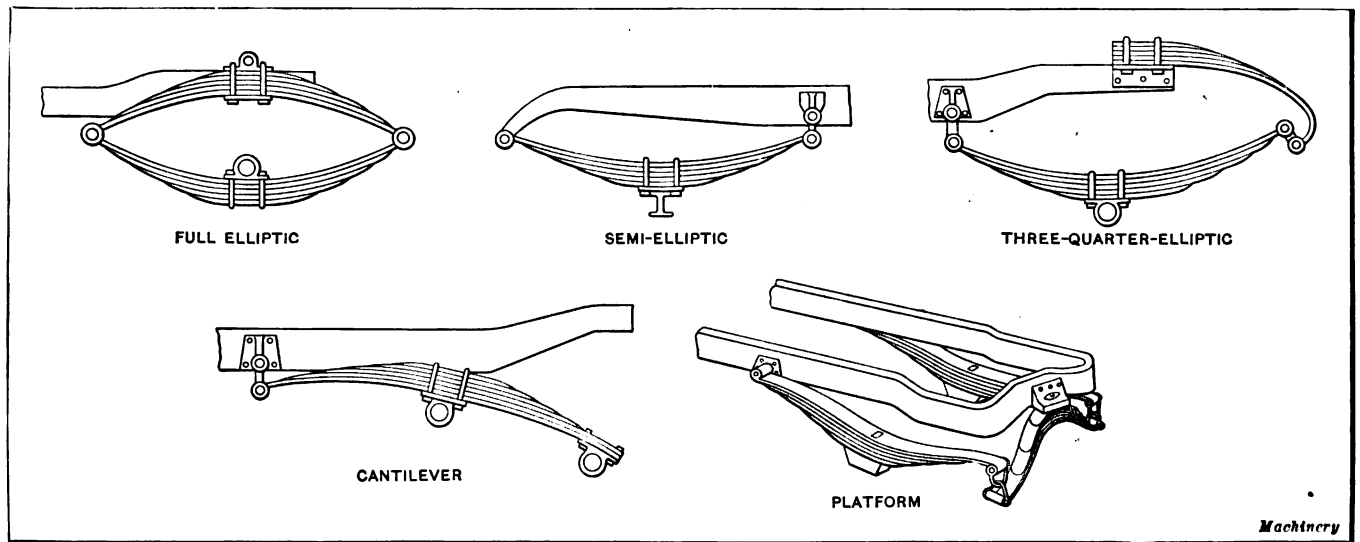

Fig. 1—Principal types of automobile springs

side sway than the other springs. Its easy-riding qualities give it popularity when installed under proper conditions. It is often made with one or both ends in scroll form. A good example of its use is found on the Franklin car.

Semi-elliptic—This spring is not as flexible as the full elliptic, nor is there as much tendency toward side sway.

\*Courtesy of Machinery.

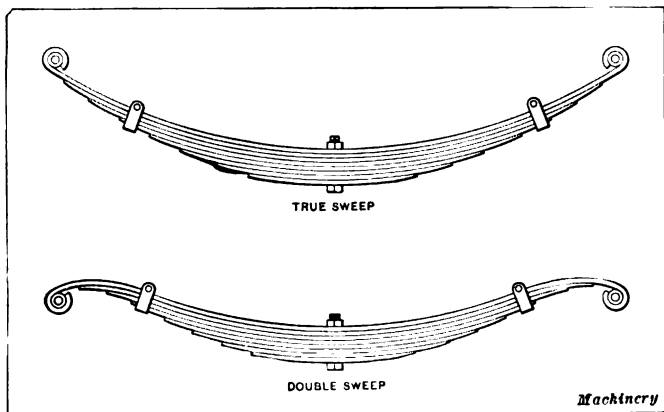

Fig. 2—General arrangement of spring plates, clips, etc., in true and double sweep springs

side sway, and the action is quite different from that of the regulation elliptic type. It is, in reality, a semi-elliptic spring mounted in cantilever form. On account of the method of mounting the cantilever spring makes the frame take a part of the spring action. It is used as a rear spring, in combination with the semi-elliptic at the front, on the Buick, Briscoe, King, and other cars.

Platform—The platform type of spring is used altogether as a rear spring and is very flexible. The action is much the same as the three-quarter elliptic, due to the fact that a quarter elliptic member is set at right angles to the semi-elliptic member, instead of in line with it, as in the regulation three-quarter elliptic. Good examples of the use of platform springs as rear installations may be found in the Packard and Cadillac cars.

A glance at Fig. 1 will show that the semi-elliptic spring member is the basis of all types of automobile leaf springs. Fig. 2 shows two types of semi-elliptical spring members, the upper of which is designated as the "true sweep," while the lower is the "double sweep" type. Of these types the true sweep spring has by far the better action, as there is less friction in the movement between the leaves of the spring. The double sweep spring is heavier in pro-

portion than the true sweep spring, and its use is confined principally to commercial vehicles.

The average length of a front spring for pleasure cars is 40 in., and for the rear spring, about 50 in.; but, of course, this varies for different weights of cars. The opening of a semi-elliptic spring, or the distance from a line through the eyes to the center of the inside arc of the spring, is from 5 to 6½ in. The leaves are usually 2 in. in width, and the number of leaves in the spring varies

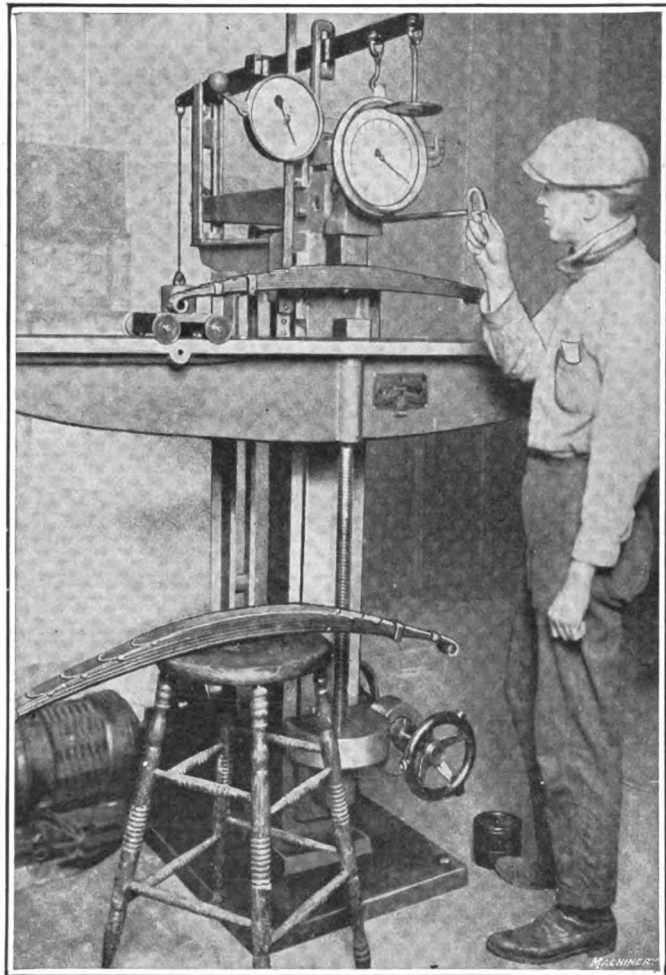

Fig. 4—Capacity test for automobile springs

with the load it must carry; there are generally from six to ten. The larger the number of leaves and the thinner they are, the greater is the flexibility of the spring. The application of this principle is, of course, limited by the impracticability of making springs with extremely thin leaves. The number of leaves and their thickness are points that are usually left to the spring manufacturer.

#### Detail of Spring Leaves

The first leaf of the spring is called the "master" leaf or "back" plate; the next leaf is the "long" plate; and the shortest leaf is the "short" plate. The usual length of the short plate is three-tenths the length of the back plate, and the spacing is evenly graduated from the short plate to the back plate. In an eight-plate spring, the spacing of the leaves is about 2¾ in. No. 2 gage steel is most commonly used for the heaviest or back plate of the spring. There are two schools of spring makers; one advocates that all the leaves of a spring should be of the same thickness; the other favors decreasing the thickness of leaves from a heavy back plate to a thin short plate.

The leaves of the spring are held together with a 5/16 in. bolt at the center; besides, at each end of one of the plates about a third of the way from the eye to the center "rebound clips" are riveted. These clips reach over the back plate, and their purpose is to keep the longer leaves from separating unduly under the rebound action. The rebound clips also help to distribute the load over the spring plates, and without them it is probable a back plate would break when put into service.

There are three methods of forming the eyes at the ends of the back plate. In some cases the ends of the spring plate are rolled upward, as in the right-hand view, Fig. 3, and in other cases they are turned downward, as in the left-hand view. Another form of eye is the "Berlin" type, which is made without bending the metal by forging the eyes solid from the ends of the back plate. The eyes are fitted with bushings to receive the hardened and ground pins.

In order to make a neater spring and to give a better spring action by relieving the abrupt strain that would be induced if the ends were left full thickness and square, the ends of the spring plates are thinned down and shaped, usually in one of the five ways shown at the left-hand side of Fig. 3. These consist of the square type of plate end, the round, egg-shaped, French, and diamond end. An end similar to the diamond shape, but with the stock left full thickness and not beveled, is also used occasionally.

To prevent the different spring leaves from swinging out of line, each plate is keyed to the one it rests upon. In Fig. 3 at the right are shown three methods of keeping the spring plates in alignment. First is the "slot-and-bead" method, in which each plate is slotted and guided by a pin in the plate beneath. Next is the "ribbed" method, in which a rib pressed in each spring plate meshes with the rib in the succeeding plate. A third method is by means of side lips. In this case the ends of the spring plate are forged out and trimmed to form lips, which are turned over so that they fit closely over the edges of the plate beneath.

#### Manufacture of Automobile Springs

At present, almost half the springs made in this country are made of vanadium steel. Many are made of chrome-silicon-manganese steel, and some are made of high-carbon steel. There are no unusual operations performed in the manufacture of automobile springs unless it may be the fitting, or cambering, of the spring plates. The stock comes in long strips and the first step is to shear these strips into the right lengths for the various leaves, or plates. In the case of the back plate, the eyes are formed; the other plates are thinned down at the ends, either by rolling or grinding, and the ends are trimmed to the proper shape. Each plate is then punched with a center hole for assembling and goes to the fitting department.

For years the method of shaping, or cambering, the plates of a spring has been to form them while hot to approximately the desired shape in bending dies. Following this operation, each plate is carefully fitted, by hand, for the position in the spring into which it is to go. After one set of spring plates has been fitted, a temporary bolt is put in to keep the leaves of that individual spring together until they are hardened, ground, and finally assembled. The operators at the fitting fires become very proficient in their work, but at best the operation is a slow one.

The modern method of cambering spring plates is by

means of spring-forming machines. These machines differ in design, but the principle of action is essentially the same in all, it being the bending and hardening in one heat. The Lewis machine carries a heavy forming turret, having two working faces, each of which is fitted with a pair of forms composed of adjustable fingers. The spring plate, after being heated to a hardening heat, is placed between the forms on the upper turret face and quickly shaped by the dies. Then while the plate is firmly held, the turret revolves and quenches it in the hardening tank beneath, thus forming and hardening the springs in one progressive operation. The pressure of the dies is maintained during hardening, thus preventing the spring from losing its shape. While the spring plate is cooling, the other turret face is presented and another spring plate is placed between the dies and the operation repeated. This method of spring-plate forming has an advantage over hand forming in that the original fiber structure of the plate is not disturbed by hammering. Moreover, this method is very rapid, as the machine will form and harden 1,800 plates per day.

When spring plates are fitted by hand, they are hardened at the same time by the fitter, each plate being treated separately. The hardening heat ranges from 1,650 to 1,750 deg. F. The plates are quenched in oil, and in many shops are tempered by flashing off the oil. This is an uncertain method, however, as the flash points of oils vary greatly. The best practice consists in drawing the spring plates in a salt bath, as the temperature can be accurately controlled and the results are far more dependable.

The eyes of the back plate are now fitted with bushings for the pins and the rebound clips are riveted to the ends of the proper spring plate. The ends of each spring plate are ground and polished to give them a finish and to permit better sliding action, and then they are assembled with the proper center bolt. In some spring-making plants high grade graphite paste is smeared between the leaves of the spring to reduce the sliding friction. The spring is now complete and ready for testing.

#### Testing Automobile Springs

Automobile springs are commonly given two tests—the capacity and the vibratory test. At the testing laboratory of the Penn Spring Works, of Baldwinsville, N. Y., through whose courtesy these testing data are given, every spring manufactured is subjected to a capacity test, as shown in Fig. 4. The testing machine is made by the Tinius Olsen Testing Machine Co., and is provided with a beam that carries two roller blocks on which the ends of the spring to be tested are supported. This is necessary in order that the springs may lengthen easily as the testing pressure is applied. It will be noticed that there are two dials on the machine. The smaller of these registers the amount of deflection of the spring, while the larger indicates the load. The spring is first mounted on the roller blocks and the plunger of the machine brought lightly down against the short plate. After the plunger has been set against the open spring, the pointer of the smaller dial is turned to zero. Pressure is now applied on the back of the spring and it must register on the capacity dial at the rate of 175 pounds for each inch of deflection, in the case of the particular spring shown being tested. This spring is one-half of a full elliptic spring and the specifications call for carrying a normal load of 1,580 pounds at a four-inch opening of the spring. As the full opening of the spring is 13 in. and at 4 in. opening the spring is deflected 9 in., it will be

seen that 1,580 pounds represents about 175 pounds for each of the 9 in. of deflection, which is as desired. All springs are set so that a tensile stress of not over 80,000 pounds per square inch will be developed in one-half the deflection, at 6½ in. deflection.

The vibratory test is a test to destruction, and is performed at the Penn Spring Works on a machine like that shown in Fig. 5. In this case the spring selected is held firmly at the ends while the center is fastened to a plunger



Fig. 5—Vibratory test for automobile springs

that, by means of an eccentric crankshaft, is given rapid vibrations of 3 in. in length. A spring is put on the machine and vibrated until it gives out by a plate breaking or in some other way, an accurate count of the number of vibrations being kept.

#### German Leather Trades Combination

According to the Munich *Neueste Nachrichten*, the leather trades in Bavaria have formed a combination which will include the whole of the organizations connected with the leather trades, and, in addition, the numerous sections of leather wholesalers and retailers who have hitherto been outside of any organization. This association will act in conjunction with the leather associations in other parts of the German empire, so that in most matters the trade in Germany will speak with one voice, and it is considered in this way the general and special interests of all sections of the trade will be most effectively served. The ground covered by the association will not be alone leather, but also the raw materials which go to make it, and all leather products.

## Flying as a Post-War Hobby

Pre-war experience clearly demonstrated two facts about flights as a recreation. The first was that as a spectacle it rapidly loses its zest. People who paid entrance fees to figure as spectators at one or two flying meetings were not easily coaxed to attend another. The enhanced spectacular values of flight, due to new stunts, better pilots, and more manoeuvrable machines, are more than balanced by the fact that an aeroplane has ceased to be a novel or even an interesting sight to millions of people.

The second fact was that, as an experience, flight can hardly be overrated. Before the war, wealthy people were ready to pay fabulous sums for a seat as passenger on special occasions, and people of very modest means readily gave a few dollars for short flights of the simplest character. This latter feature should be far more marked in days to come. Flying is infinitely safer than it was in 1914, and its safety will be increasingly demonstrated when the "Archies" are silent, and chance-encountered 'planes no longer carry machine guns. Not to have been "up" will soon confer a humiliating notoriety.

The ex-service pilots, no matter how they may have been bored by a year of artillery observation, or how gladly they heard the medical board's verdict, "Unfit for further service as a flying officer," will begin to sigh for a renewal of the old sensations, in so far as peace can recreate them, at any rate.

Every high-spirited youngster of both sexes will want to make a flight, and having flown, will desire to repeat the experience. Many whose age or physique or fate withheld them from aerial duties in war time will seek an early chance of a "flip" after the war. Unquestionably, if flight as a spectacle has largely lost its interest, flight as an experience must appeal to a vastly increased number.

### Probable Cost of Aeroplanes

It is thus more than possible that flying will very shortly enter upon the stage of becoming a rich man's hobby, and the limits of its popularity will be determined mainly by its expense. So far as the original purchase of an aeroplane is concerned, flight as a hobby will be little more expensive than billiards and dozens of other pastimes which are almost universal in certain walks of life.

A useful and speedy type of single-seater aeroplane could be turned out at the present cost of labor and material for about \$1,500; it would have a simple type of engine, rated at from 20-40 h.p. The next phase would be the Ford aeroplane, which, judging from precedents, would ultimately sell at about \$375, f.o.b. at Detroit, and would be bought and used by every member of every country club in America. Then it would be imported into England, ridiculed in millions of comic yarns recounted at every club, garage, and smoking room, and would sell like hot cakes.

Unfortunately, the purchase of the aeroplane is one of the least considerable expenses associated with flying. Having found the cash for your aeroplane, you must learn how to fly it, and \$250 is a moderate estimate of the probable fee, even when competitive schools spring up like mushrooms, as they will.

A small hangar will serve to house the private single-seater, and its rent will not be large, especially as aerodromes will be well outside the cities on cheap land. But few individuals can afford to rent a large area of level ground in return for an occasional flight in fine weather.

Still fewer individuals can support a staff of highly trained mechanics and a well equipped workshop; and the type of man who will take up flight as a hobby will not be exclusively of the temperament that enjoys doing its own dirty work, and can do its own skilled repairs.

### An Additional Attraction to Club Life

Some form of co-operative flying is clearly indicated on all counts, and two alternatives present themselves. One is that sporting aerodromes will gradually be laid out as adjuncts to country clubs and golf links.

Membership of such clubs will be expensive, but will offer a variety of attractions. When golf bores, one can fly; when the weather is too rough for golf or aviation, one can play bridge or billiards. The hangars and the air mechanics' shop will balance the golf professional's shop and the lock-up garages. Just as you can book Braid or Mitchell for an hour to take that slight hook off your drive or to instil a little extra cut into your mashie approach, so you will engage some famous champion of the clouds to improve your landing, or to teach you the newest trick in stunts. The other alternative is less gilded.

### Commercial Aspect

Commercial aerodromes will gradually dot the countryside. Some of them will be associated with factories, others will be depots for mail or passenger routes, some of them—eventually—will fleece the hedgetop aeronaut, as their predecessors, the garages, fleeced the roadside motorist. Like the garages, they will soon regard all that comes to their net as fish. Above all, they will fill in some of the abundant leisure flying corps may expect during the air slump that must follow the air boom, by teaching people to fly, by renting them hangars for their private 'planes, and by allowing them the use of their aerodrome in return for a rigid quarterly fee and an extremely elastic quarterly bill.

It is more than likely, indeed it is practically certain, that during the next ten years all these things will happen, and many of our present incredulous readers will put money in such schemes, or help to swell the profits or reduce the losses of those who do.—Autocar.

### Old Coach Builders Plan Expansion

E. E. Vreeland, formerly treasurer and advertising manager of the Fulton Motor Truck Co., has resigned in order to become president of the Abbot-Downing Truck & Body Co., Concord, N. H., successors to the Abbot & Downing Co. of that city. The new company will continue the manufacture of the Concord motor truck in a wide range of models, and increase its production to a volume that will enable it to become more of a figure in the trade. Heretofore it has been marketed only in New England.

The Abbot-Downing company is an old one, having started as a builder of stage coaches. It made the original "Deadwood" coach used by Buffalo Bill, and also some of the first railroad coaches. Its first truck was made about two years ago. Models are to be made in 1, 1½, 2, 2½, 3½ and 5-ton sizes.

Mr. Vreeland has had much experience in the past. As the head of E. E. Vreeland, Inc., a New York City advertising agency, he has had a share in the reorganization of a number of manufacturing concerns, in which he became financially interested.



**Rapid Detachable Wheel**

**An Ingenious Locking Mechanism Enabling a Wheel to Be Detached or Refitted in Less Than Four Seconds**

Having by means of his self-lifting jacks reduced the time required to raise the wheels of a car to a matter of seven seconds, Fred Lionel Rapson, of England, the inventor of the Rapid jack, described in the December, 1917, issue of The Hub, has now introduced a form of a detachable wheel capable of being removed or replaced in less than four seconds, and which is described in Autocar as follows:

One noteworthy feature of the wheel is that the locking device is operated by the same small handle by means of which the hand-operated Rapid jack is brought into or taken out of action, the idea being that for the two operations of raising the car and changing a wheel only the one accessory is needed.

A special feature of the Rapid detachable wheel is that in being refitted there is no thread to be engaged, the thread of the locking device being always engaged. In other words, there is no thread on the exterior of the fixed hub—a thread which is liable to be damaged or burred when the detachable hub is pushed into position. The thread shaft of the Rapid wheel is rotated by the

Referring to the accompanying drawings, Fig. 1 shows, in part section, details of the locking mechanism of the Rapid wheel, and also the inner and outer hubs, driving axle, ball bearings, and other usual details, the whole of the additional mechanism being to the right of the end of the driving axle end.

The details of the Rapid mechanism can be seen more clearly in Fig. 3, where the end of the fixed hub is shown at A partly in solid section. Near the outer end of the hub four slots are formed in order that the locking toggles may pass outwardly to engage with the detachable hub. Screwed within the fixed hub, and locked therein, is a toggle plate, B, which supports in a central bearing the end of a thread shaft, C, the outer end of this same shaft being supported within a bearing formed in a capped end of the fixed hub. Mounted on the threaded portion of this threaded shaft, and screwed internally to suit, is a flange or disc, D, supporting the outer ends of the toggles, E, of which there are four sets spaced equidistantly inside the hub.

The screwed shaft C is hollow as to a considerable portion of its length, and the outer end has a hole of square section to correspond with the square shaft of the operating handle.

Referring still to Fig. 3, where the outer detachable hub

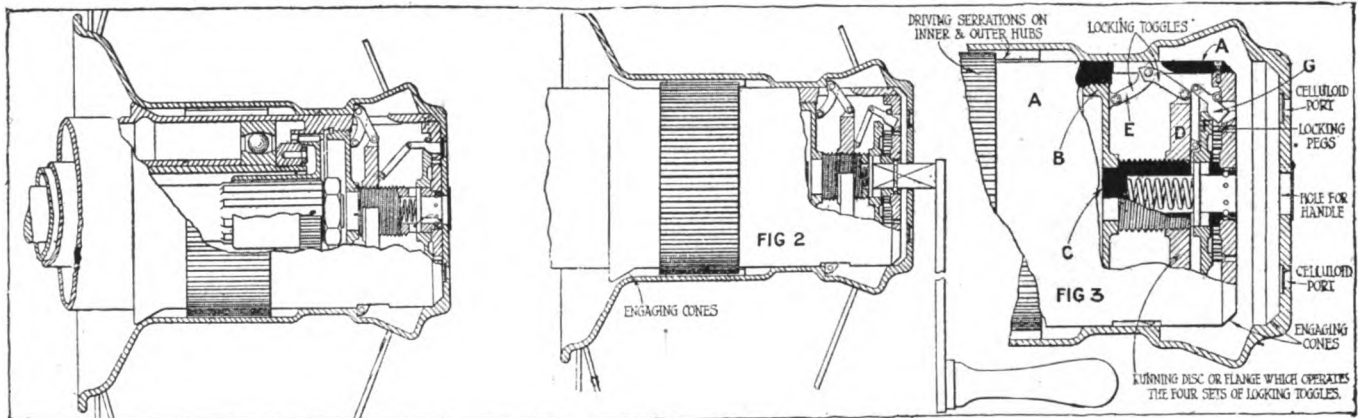

Fig. 1—Part sectional view of the Rapid detachable wheel. The locking mechanism is entirely enclosed within the outer end of the detachable hub. In this view the detachable hub is shown locked in position as in normal use. Fig. 2, showing the outer hub in the process of being forced "home" by the toggles, the operating handle being in position. Fig. 3 shows the locking mechanism in detail before the outer hub has been pushed on to the inner hub far enough for the toggles to be brought into action

detachable handle, but is never disengaged from the flange or sleeve working upon it; thus there is no possibility of crossed or jammed threads when the wheel is being refitted. Further, the threaded portion of the device is entirely closed within the fixed hub, instead of, as usual, being on the exterior of this portion of the wheel.

The principal of the Rapid wheel is similar to that of certain types of friction clutches whereby sets of toggles, coupled at one end to a fixed portion and at the other end to a sliding member, open outwardly at their central pivot, which at the same time moves laterally. This lateral movement in the case of the Rapid wheel serves to force the outer hub shell on to the fixed hub. The latter has two beveled surfaces, one at each end, corresponding with beveled surfaces inside the outer hub; consequently the operation of the toggles forces the outer hub home on to these bevels, thus centralizing the wheel and preventing lateral movement.

The drive from the inner to the outer hubs is, as usual, taken by serrations formed on the two parts concerned, so that the frictional grip provided by the toggles is in no way depended upon to convey the drive.

is seen partly engaged with the driving serrations as it would be before the locking device is operated, it will be noted that the beveled end of the inner hub is some distance away from the similar bevel within the outer hub. If now this outer hub be pushed laterally on to the inner hub, these bevels will come into engagement as shown in Fig. 1. To secure the outer hub in this position the operating handle is inserted in the square end of the shaft C and rotated. The effect of the rotation of the shaft is to move inwardly (to the left in the drawing) the flange D, and to drive outwardly and laterally the pivoted centers of the toggles.

Referring to Fig. 2, where the toggles are seen coming into action and the operating handle is in position, it will be noticed that the pivoted centers of the toggles tend now to force the outer hub into position when the handle is further rotated. Actually seven complete turns of the handle are needed either to withdraw the toggles from their fully locked position or to move them so as to secure the outer hub after it has been pushed on by hand.

To prevent any possibility of the wheel becoming unlocked in use, a disc, F, is provided with a number of pegs.

which, when the operating handle is withdrawn, are forced outwardly through holes in the end cap of the fixed hub by the stiff helical spring shown within the threaded shaft C. When a wheel is to be removed, the action of pushing the operating handle into position forces back this disc, and puts the pegs out of engagement, the handle being held in position for the time being by a series of small spring-backed balls engaging with grooves in the handle shaft. A sharp pull outward is sufficient to disengage the handle and allow the pegs to fall into the holes provided for them when the wheel has been secured in position.

In order that the operator may have some plain indication as to whether the wheel has been forced well home and locked, a safety indicator is provided, this taking the form of a single toggle, G, coupled to the threaded flange D in such a manner that, when the flange has been moved as far toward the left, or locked position, as possible, the enlarged end of the indicator can be seen through a celluloid-covered port formed in the end plate of the outer detachable hub. This port is an almost complete circular slot in the end plate, and allows the word "Safe" on the

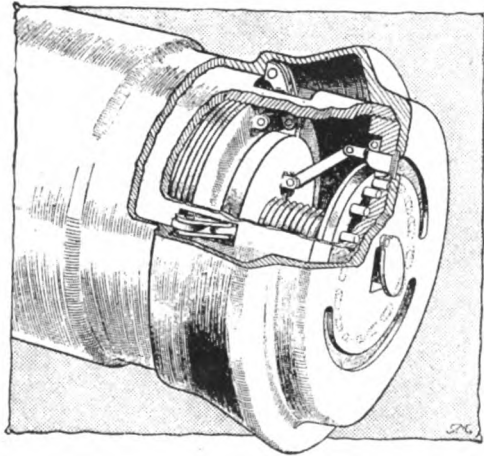

Fig. 4—Perspective sketch showing how the locking toggles project through slots formed in the inner or fixed hub. Also shown are the celluloid covered ports in the end of the detachable hub through which the safety indicator can be seen when the wheel is locked

end of the indicator to be seen within a special hole in the outer hub end plate. The aperture for inserting the operating handle in this outer plate is normally covered by a hinged plate, which prevents the entry of dirt, water, or dust.

From the foregoing description it will be seen that, although at first glance the mechanism of the hub may seem somewhat involved, yet in reality there is nothing complicated about it. So far as operating the wheel is concerned, nothing could be simpler: the handle shaft is pushed in, the handle given seven turns, and the wheel pulled off. In refitting the wheel the outer hub is pushed on to the inner hub as far as possible, the handle engaged and turned seven times, and a glance given to see that the safety indicator is visible through the celluloid-covered port.

It should be noted that the insertion of the handle shaft automatically takes the locking pegs out of action, while, when the wheel is in position, the removal of the handle allows the pegs to fall back and prevents any likelihood of the locking mechanism moving of its own accord.

With regard to the removal of the locking mechanism if it should be required at any time to have access to the ball bearings of the fixed hubs, or to remove this hub for

any purpose, it is necessary only to remove a grub screw in the inner hub, when the entire mechanism can be unscrewed and taken away intact.

## Wagon and Vehicle Committee

Frequent references have been made to the wagon and vehicle committee which is co-operating with the U. S. Quartermaster Department in the purchase of wagons and other vehicles for army use, but the status and duties of the committee have not been made public. In order that those interested may know what the committee is doing the following statement has been prepared by Col. W. S. Wood, depot quartermaster, Jeffersonville, Ind.:

### Government War Wagons

Jeffersonville, Ind., February 17, 1918.

There was established in April, 1917, at the Jeffersonville depot of the quartermaster's department, and in the office of the Quartermaster General at Washington, a wagon and vehicle committee, for the purpose of advising and assisting the depot quartermaster at Jeffersonville in placing the large orders of vehicles and transportation, which it became evident would be needed for the successful prosecution of the war.

This committee was composed originally of R. V. Board, of the Kentucky Wagon Mfg. Co.; A. B. Thielens, of the Studebaker Corp.; R. W. Lea, of the Moline Plow Co., and E. E. Parsonage, of the John Deere Wagon Co. The official standing of this committee is as follows:

1. It is the official committee of the Jeffersonville depot advisory to the quartermaster in charge of that depot.
2. It is a committee officially recognized by the office of the Quartermaster General in Washington.
3. It is a committee officially recognized by the War Industries Board at Washington.
4. It is also an official committee of the National Implementation and Vehicle Association.

This committee meets at Jeffersonville upon the call from the depot quartermaster and the actions taken from that depot upon the recommendation of the committee are the official actions of the quartermaster department, represented by the depot quartermaster.

Since its foundation this committee has been somewhat changed. E. E. Parsonage now acting as the advisor of the War Industries Board at Washington upon matters pertaining to vehicle; and H. J. McCullough, of the Emerson-Brantingham Co., having been added as a member, as was also Thos. A. White, of the St. Marys Wheel Co. P. B. Schravensande, of the Grand Rapids Equipment Co., Grand Rapids, Mich., representing some 1,200 manufacturers and furniture industries, has been added to the sub-purchasing committee and as the advisory with the wagon and vehicle committee.

The sub-committee, so-called purchasing committee, meets every Thursday in Chicago at the LaSalle Hotel, which meetings are open to those interested. Prices paid for vehicles, etc., are fixed by the War Industries Board upon the recommendation through proper channels of the depot quartermaster at Jeffersonville.

## Truck Companies Young

The records show that of 217 motor truck companies listed today only 8½ per cent have been in existence more than five years and only 36 per cent for more than three years.

### Home-made Tire-setting Device

How Fred N. Roehlk, a St. Louis, Mo., wheelwright saves time and labor in the setting of tires is thus described by James F. Hobart in *Blacksmith and Wheelwright*:

The writer was greatly interested in the speedy manner in which tires were set at this shop by means of the apparatus shown at Figs. 1, 2 and 3. Home-made apparatus, every bit of it. The "wheel block" shown at Fig. 1 needs

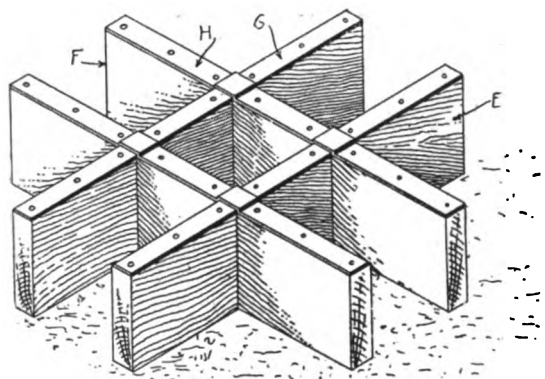

Fig. 1—The wooden wheel block and showing method utilized in fastening the strap irons

little description save to state that the 3 x 12 in. planks were carefully halved together as shown at E and F, then the four 5/8 x 3 1/2 in. tire iron straps G and H were fastened on by spikes, home made, with round flat heads, which were countersunk into the iron straps. These straps, by the way, were not fitted flat on top of the frame E F. Instead the straps G were fastened, then the other pair of straps H were forged to fit right over the first pair as shown. This left four high places but it did no harm.

The home-made slack trough was about 20 in. square and nearly 6 ft. long, as shown at Fig. 2. This trough was no different from any other, save for the two standards, J, J, which were bolted to the sides of the trough at the middle thereof. Each standard carried several 3/4 in. steel pins, bore-driven tightly into the wood, and each pin on either standard was placed level with the corresponding pin on the other standard.

The apparatus shown at Figs. 1 and 2 was located just outside of the smithy door. Just inside was the gas heater, a machine which, the writer was informed, had been furnished by the gas company. The machine consisted of a metal table upon which several tires could be piled horizontally and against the piled tires was made to play gas flames from nine segments, each segment full of small holes from which issued the blue-burning mixture of gas and air, the latter being supplied by an electrically-driven fan.

The segments, to each of which a gas hose was attached, were adjustable and the segments were moved in or out according to the diameters of the tires to be heated. Some inquiries made as to the cost of thus gas heating tires for setting brought forth the information that a record kept of setting 285 tires showed that the cost of gas averaged eight cents per tire. "And the tires were nearly all heavy ones, too," remarked Mr. Roehlk, as he handed out the desired data. "My smith and two helpers can heat a tire and set it inside of six minutes, easy. And when there are several tires to be set at the same time, as is usually the case in this shop, the time of heating and setting will

not average much more than four minutes for 3 x 5/8 in. tires, which we set a whole lot of."

### Method of Setting Tires

The gas machine is provided with a weighted or counterbalanced sheet iron cover which may be pulled down over the batch of tires which may be in heating, thus protecting them from drafts of air. But the cover device is seldom, if ever, used, only in case of a large number of very heavy tires. For ordinary work the smiths find that it does not pay to spend the necessary time for pulling down and raising the weighted cover.

While the tire is heating, the helpers place the wheel, shown at Fig. 3, dished side down, upon the wooden wheel block. Two sledges are provided and placed near by. When the smith comes, he brings his forging hammer with him.

When the smith regards the tire as being hot enough, a nod from him starts things amoving. The two helpers grasp the tire with tongs and carry it to the wheel block just outside of the shop. If it should be the last tire of a bunch on the heater, the smith shuts off the gas and air before he follows his helpers. Should there be other tires heating, the smith sees that the segments have not been disarranged in removing the tire from the heater, then he follows his helpers with the tire and gets there by the time they have laid the tire upon the wheel, as shown at Fig. 3, at M, and have placed the several appliances in position.

A wooden pole, N, is at once thrust over the rim L and tire M, which, at the point where lever N is placed, is flush with the top of the wheel rim. The inner end of pole N is caught under the hub of the wheel or under the wheel block and one helper promptly straddles the pole N so as to prevent the tire from working upward at point L.

While all this is going on, and it is done in a very few seconds, the other helper has placed in position the piece of steam pipe (about 2 in. pipe) shown at P, also the grab link O, several of which, of various lengths, are scattered around and near at hand.

By the time the second helper is ready to give a pry on pipe lever P, the smith is on the job and is banging away

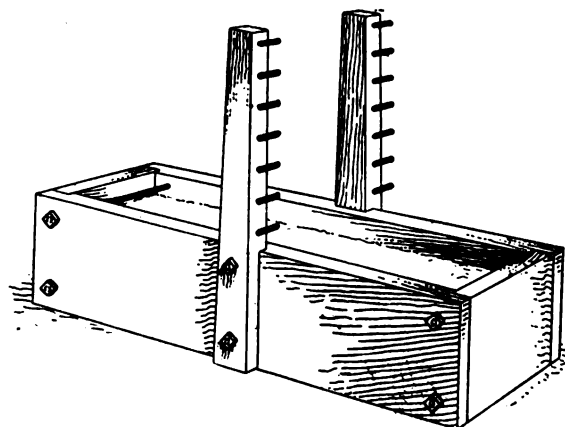

Fig. 2—The wheel trough used in conjunction with gas heater for heating tires

with his hand hammer at any spots inside of tire M which may fail to slip readily over the rim of the wheel. Inside of a very few seconds the tire is forced into place. The second helper thrusts his pipe lever through the hub of the wheel, gives a heave, the first helper raises his side of the wheel after dropping his wooden lever and the wheel is quickly placed upright upon the wheel block.

The smith runs his eye over the tire and rim, strikes any places in the rim which have not been centered, then the two helpers, one at either end of the pipe through the hub, place the wheel upright in the slack trough with the piece of pipe resting upon two of the pins in the standards. The pins used are those which will permit the wheel to hang with its lower edge in the water and without touching the bottom of the trough.

Both helpers then stand by with the sledges. One strikes smart blows on the face of the tire as the smith revolves the wheel in the water, driving back any bit of felloe which may not be properly centered, and directs

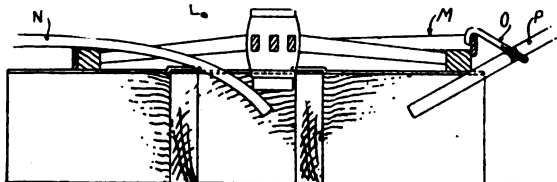

Fig. 3—Illustrating tools and apparatus used in quickly and easily setting the tires

the other helper where to strike sledge blows in case any may be required to properly center the rim in the overhanging tire.

The above bit of work was about as pretty a sample of team work as the writer has ever seen in a smith shop or out of it for that matter. The writer timed the setting of one 2 in. tire. The entry in my notebook reads:

Lighted gas, 4:25  
 Started air, 4:26  
 Tire hot, 4:27  
 Tire set, 4:30

Five minutes to a single tire is surely not so bad. Wonder how long it would have taken in a fire in the yard or in the best tire-heating furnace one can build?

### To Further Standardize Farm Wagons

The farm wagon department of the National Implement and Vehicle Association held a meeting in Chicago February 28 and March 1. The attendance was the largest in the history of the organization, 65 farm wagon manufacturers being represented. The Southern Wagon Manufacturers' Association and the Memphis Implement and Vehicle Association were also represented by delegates.

A feature of the meeting was a talk by Colonel W. S. Wood, depot quartermaster, Jeffersonville, Ind., who told of the army's need of wagons. He also spoke of the desire of the government that the needs of farmers in wagon and trucks for handling 1918 crops should be fully supplied in addition to army requirements. He emphasized the fact that the wagon supply for the farm is an absolute necessity. Col. Wood requested that wagon manufacturers make an estimate of the number of wagons and trucks they expect to produce for farmers' use this year and state the percentage of this to the normal annual production.

Discussion of conditions revealed that if factories are supplied with materials, enabling them to operate without interruption, their product, aside from war wagons, added to stocks already on hand at factories and transfer points and in dealers' hands will be sufficient for farm needs. It was stated, however, that it will be necessary for farmers to utilize all of their old wagons which can be repaired and placed in workable condition. The repairing of farm wagons should be encouraged.

It was stated at the meeting that, notwithstanding the progress that has been made in the standardization in farm wagons, plans are being made for further reduction in types. It has been suggested that farm wagons and trucks be made with all four wheels of one standard height; also that wagons be made in one track only to conform to the automobile standard of 56 inches. These and other matters will be considered at the next meeting of the wagon manufacturers to be held at Louisville, Ky., in April.

### Shell Company Formed by Detroit Automobile Men

A \$2,000,000 corporation has been formed in Detroit to make shells for Uncle Sam. It is to be known as the Detroit Shell Co., and has for its officers men prominent in the automobile and allied industries. They are: President, John Kelsey, president of the Kelsey Wheel Co.; vice-presidents, Harry M. Jewett, of the Paige Motor Car Co., and Roscoe B. Jackson, of the Hudson Motor Car Co.; treasurer, Edsel Ford, of the Ford Motor Co., and secretary, J. Walter Drake, of the Hupp Motor Car Co.

Incorporation of the company followed shortly after the visit of the Automobile Industries Committee from Washington, Hugh Chalmers, chairman; A. W. Copland and John R. Lee, and the offer of an initial contract for \$30,000,000 worth of munitions, with the prospect of more business to follow. The new company has taken over the immense new plant of the Springfield Body Co., in Springfield, containing some 200,000 sq. ft. of floor space and it is anticipated that between 8,000 and 10,000 men will be employed.

### Wood Wheel Manufacturers Meet

The Automotive Wood Wheel Manufacturers' Association, recently formed, is planning to protect the interest of its members through a widespread campaign looking to the furtherance of the wood wheel industries. A committee, consisting of S. Vance Lovenstein, of the Schwarz Wheel Co., Philadelphia, Pa., as chairman; B. I. Porter, Auto Wheel Co., Lansing, Mich.; A. E. Smith, Hayes Motor Truck Wheel Co., St. Johns, Mich., and C. C. Carlton, Prudden Wheel Co., Lansing, Mich., was appointed to carry out details of the plan. The association states that three planks in its present program of procedure are: An answering loyalty to the United States government in productivity; a determination to set its position clearly before the manufacturer, dealer and consumer of trucks and passenger cars and co-operative plans for standardization.

### Automobile Body Lumber in Demand

Hardwood lumber manufacturers at St. Louis, who sell largely to automobile body builders, say that more orders are being received now than for several months past. Large buyers are convinced that sap gum will not answer for body building, and that manufacturers are returning to ash, and to maple for cheaper bodies. Prices of maple and thick ash have been advanced, the former because of an insufficient supply, and the latter as a result of the heavy use in airplanes and vehicles. Automobile body ash, less than 2 in. in thickness, is quoted at \$80 for first and seconds, and \$64 for No. 1, as compared with \$58 and \$35 a year ago.

### Setting Axles

A Victorian coachsmith who always attached great importance to setting axles used to make it a practice to test the first arm in the wheel by trying it with a long stick diagonally between the tire of the wheel and the collar of the opposite arm. He then adjusted the axle gauge to this arm and set the others from it. This method had disadvantages. It was slow; at least one of the wheels had to be boxed before the axles could be set; and, with the ordinary shop gauge there was always the element of guesswork.

Acting on the principle that the surest way to get a uniform set on all four arms was to try each arm separately, the emith referred to devised the axle setting gauge here illustrated. It consists of three parts: a forged stay A, which is intended to represent the end elevation of one half of a wheel; and B, a long bar,  $\frac{3}{4} \times \frac{1}{4}$  in., with a short adjusting foot, C, at one end held by a counter-sunk bolt and thumb nut working in a slot. Assuming the average height of wheel to be 4 ft., the fork A is made 2 ft. long. The bar B has a number of holes bored in one end so that it can be adjusted to suit various lengths of axles.

At first sight this gauge may appear cumbersome and slow, but the opposite is the case. It is being exclusively used in a shop where ironwork is being turned out in large quantities for the trade, the old fashioned gauge being discarded as obsolete.

The method of working is as follows: The fork, A, is placed on top of the arm to be set, with the inside leg pressed close to the collar and held by the boy; the foot, C, at the other end is adjusted to any point on the opposite arm, such as inside the collar. On turning the axle upside down and applying the gauge in the same way the turn-under can be checked to the desired amount. In the same way the arm is tested sideways for gather.

#### Drilling a Long, Small Hole

One of the most awkward jobs, and one beset with many troubles, is to drill a  $\frac{3}{8}$  in., or similar small hole 4 or 5 ft. up a shaft, say, for lubricating purposes. Occasionally one comes our way, and we set about it as follows: Taking a shaft 8 in. in diameter by 9 ft., to have a  $\frac{3}{8}$  in. hole up the center for a distance of 5 ft., the shaft, after

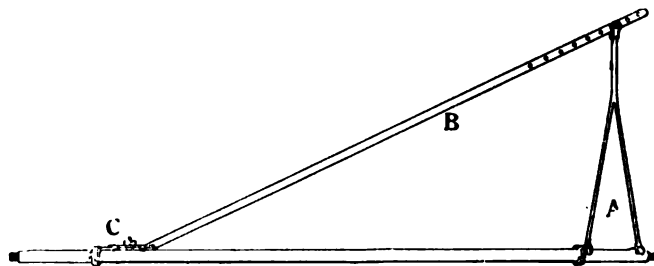

being turned, is held in the chuck at one end, and run in a steady-rest about 12 in. from the other. The hole is commenced with an ordinary twist drill held in a drill socket in the loose head-stock, and this results in a depth of about 4 in. Another drill, which has been welded into a piece of round bar 12 in. long, is then used to its full length, and succeeded by another 24 in. long, and so on until the last drill is of the desired total length. The twist drills are welded into the bars with welding compound, as shown at the top of the illustration.

The old way of taking a piece of steel the full length required and making a twist drill of the end by drawing it out and while hot twisting it in the vise is a long and temper-trying way. The point has not the stability of a standard drill, nor is it possible to grind it with the cutting clearances, and the point is more likely to break off in bits, especially as it has to be hardened often. Anyone who has tried this will agree it is very hard to feel whether or not the point is cutting after going a very short distance, as the bar soon begins to bend in the middle, and the sensitiveness is gone.

By using drills in different lengths this feeling is retained, and much greater progress can be made, as the major portion of each drill, after the first one, acts as a stay in the hole. It is now an unusual occurrence for the point of the drill to break by this method, but in the event of this happening we have a very quick and effective method of getting out the bits. The method is to take a piece of high-speed steel and grind the end as shown in the center view. This is inserted in the hole, the lathe set running, and the end of the bar hit sharply and quickly with a hand hammer. The action jams the bar end against the bits of drill embedded, and if at the time the bar is struck the end is on a place in the bar and at the side of the bit of drill, it tends to have the same action as a center punch, and will therefore compress the shaft and eject the drill bit; this is illustrated in the lower view.—American Machinist.

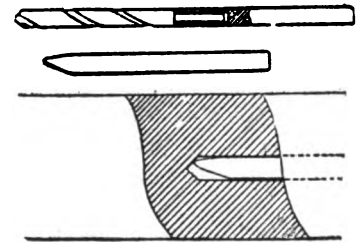

### Truck Makers to Meet Often

Regular meetings of the 45 commercial vehicle manufacturing members of the National Automobile Chamber of Commerce were decided upon at a recent meeting of representatives called to discuss matters of special interest to this branch of the industry. Many motor truck makers have been admitted as new members of the organization during the past year and one of the principal objects of the regular sessions is to promote better personal acquaintance among them and afford opportunities for discussing their particular problems in greater detail, such as have been enjoyed by most of the passenger car makers in the chamber for many years.

In recognition of the growing importance of this branch of the industry, two divisions of the membership of the N. A. C. C. were created some time ago—a passenger car division and a commercial vehicle division, each in charge of a second vice-president. A great deal of the activity of the association and of special committees at work in Washington now centers around the motor truck.

Advisability of holding truck shows in New York and Chicago next winter was discussed at the recent meeting but not action was taken. Appointment of a sub-committee to investigate and report on several matters of trade interest was agreed upon.

### Atlantic City to Have Auto Show

Atlantic City will have an over-the-ocean automobile show this year on the Garden Pier. It will be an Easter event, and will run from March 30 to April 6.



## Unit Delivery Car Bodies

The systematic production of automobile chassis of various makes, in very large numbers, has given us thoroughly tested designs suitable for either pleasure or light delivery work. Formerly, the fitting of bodies was custom work and involved considerable fitting and trying before completion. The justification for this was the difference in the chassis that were brought to the body maker for conversion purposes. Just as soon as automobiles of certain makes were standardized, body makers were enabled to devise bodies for various kinds of commercial work that could be manufactured economically and sold at a price commensurate with that of the chassis to which they are adapted.

The bodies shown in the accompanying illustrations, taken from Scientific American, are based on an ingenious scheme of construction, in which units are added to a standard base to produce the type desired. As the units are put through the factory in large lots, costs are greatly reduced. For use in summer, the open side or screen side bodies are well adapted to the transportation of certain

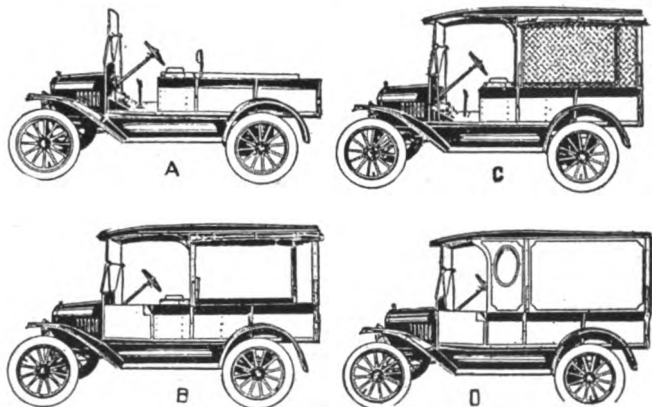

classes of goods that demand more thorough protection with the coming of the cold or unsettled weather. With the body shown at B it would be the work of but a few minutes to change the screen sides for solid panels and the change could be made by any man who can use a wrench and hammer. Another advantage is easy replacement of any broken part. A careless driver may damage a side panel by colliding with some object, and even the most careful operator is liable to have an accident, through no fault of his own, in which a flare board or tailgate will be damaged. With the unit construction, a new part can be obtained at small cost, and may be readily replaced, because the units are all interchangeable.

All bodies are built of steel, with a steel skeleton frame, which is said to make a body one-third lighter and two-thirds stronger than the equivalent all wood construction. The primary unit is shown at A. This is an open body with flare side panels and tailgate. It approximates the justly popular express type. By adding a canopy top with roll-up side and rear curtains one has the covered express body shown at B. The posts are attached to the outer edge of the flare boards and the full loading space is preserved. For light parcel delivery, the screen side body is very popular. This is obtained by adding stout screen panels to the body shown at B and the type shown at C is available. By substituting solid steel panels for the screens and putting quarter panels at the driver's seat and full-length doors at the rear, a completely enclosed body as shown at D is produced.

## Carriage Makers to Assist Government

The Carriage Builders National Association held a special meeting at the Hotel Gibson, in Cincinnati, on March 7, at which it was decided to appoint committees to work with a view to helping the government win the war. Philip E. Ebrenz, St. Louis, former president of the association, who was chairman of the meeting, named the following members of the war service committee: A. T. Jackson, Rockford, Ill.; William H. Roninger, St. Louis; H. H. Crawford, Kalamazoo, Mich.; W. G. Norman, Griffin, Ga., and Frank Strong, Chicago, Ill.

This committee will go to Washington immediately to confer with the War Industries Board or other bodies to determine in what way the carriage man can help the nation.

Chairman Ebrenz also appointed a standardization committee. This was after the meeting had adopted resolutions favoring such a committee to take up and outline the fundamental parts of carriages with a view to making it possible to facilitate the securing of raw material and relieving the steel mills and supply houses by such uniform usage.

A representative of a steel company who was present stated that his firm had to keep 65 different samples of metal on hand to supply the wants of carriage manufacturers who needed it to build buggies, and no two seemed to desire the same thing. By standardizing carriage parts a great deal of conservation can be accomplished. The following were appointed to this committee: A. C. Hill, South Bend, Ind.; Theodore Luth, Cincinnati; H. G. Phelps, Columbus, O.; Frank Delker, Henderson, Ky.; H. A. White, High Point, N. C., and P. E. Ebrenz.

Among others who addressed the meeting were Ed. Schlamp, Henderson, Ky.; G. H. Post, Columbus, O.; I. M. Baum, Ligonier, Ind.; H. H. Ahlbrand, Seymour, Ind.; C. R. Crawford, St. Louis, and C. L. Fehring, Columbus, Ind. The meeting began at 10 a. m. and lasted until evening.

## Sheldon Entertains and Gives Instructive Talks to Dealers

At the Copley-Plaza Hotel, Boston, Mass., March 7, the Sheldon Axle Co. gave an entertainment and buffet luncheon to a large number of dealers handling trucks equipped with Sheldon axles. Sales Manager F. L. Martin gave an instructive talk, illustrated by lantern slides, on the features and method of manufacture, etc., of the axles, so that dealers might speak intelligently of the mechanical points of superiority. A pamphlet was also distributed to further the same end. Richard Schaaf, spring engineer of the company, gave a similar talk on the spring construction.

After the luncheon an open session was held, in which Mr. Martin and Mr. Schaaf were assisted by the eastern representative, J. A. Young, in answering questions of the dealers.

## Perrine Advances in Standard Parts

W. E. Perrine, production manager of the Standard Parts Co., Cleveland, O., has been advanced to assistant general manager and chairman of the executive board of control, carrying on the work of Christian Gird, now occupied at Washington with matters relating to the production of motor trucks for the government.

## Paint and Varnish

### Some Show Observations

The New York shows, as well as some of the other shows which have recently been held in many of the larger cities, brought out the fact that not a few of the old standbys in the color world are still strong favorites with the average car user. The grays, for example, are still looked upon with much favor by some of the most conservative drivers who, in addition to getting a smart color effect, desire a pigment that shows the dirt and dust at the minimum, wears well, and requires the least possible amount of upkeep labor and expense. The grays are put out for the season under an almost imposing array of names, many of them savoring of the war and the trenches, and so on. Nevertheless, they are colors for the poor man and the rich man, and the class in between, and they have many merits. Hence their popularity.

The blues and blacks and greens are also colors which retain an undiminished favor with practically all classes of car users. They are the colors of the royalty, as well as the common people, all of which accept them gladly. Then there are maroons, an exceedingly useful class of pigments, having a splendid depth and volume of color, with enough lustre to give them many admirers. They deserve all the good words spoken in their favor, for in addition to being fine and radiant colors they have established durability with a comparatively small maintenance cost.

All these colors here spoken of are solid colors—that is, they do not as a rule require ground colors especially made for them. There are a few of the blues, to be sure, that must be teased along with a special ground as a means of fetching out the color possibilities of the pigment, but in the main the colors are solid covering, and after fitting the surface up smooth and fine, the color is just laid on sleek and velvety. Usually one coat of color and then one or two coats of varnish-color over this will suffice to fetch out the color in full lustre and power. Maroon will go directly to the surface, but one coat may be saved, as a rule, by first applying a coat of Indian red, japan ground, and then one coat of maroon, to dry flat. Following this one or two coats of varnish-color will bring out the desired color effect. In this case, as in the case of most colors of this type, it is a necessary practice to use a little color in the successive coats of varnish as a means of keeping the color pure and brilliant. For really fine work single and double lines of striping serve to bring out the best possible contrasts.

### Striping the Car Coming Into Favor

Another point was brought out by the recent automobile shows, namely, that striping is by no means a lost art. At the Salon, Hotel Astor, New York, one could see striping effects which might remind the old time carriage user of the days of long ago. Here were cars striped in a manner worthy of the best traditions of the trade. It proved the fact, as one exhibitor stated it, that striping is popular when people have the money to pay for it.

At the Salon there were some exquisite examples of fine lining, and it was noticeable that the double and even three-line stripe came in for a good deal of attention by the liners. Many of the lines were  $\frac{1}{4}$  in. lines edged with some fine line of contrasting color. On some of the deep green fields the  $\frac{1}{4}$  in. line was of black edged with a fine line of gold. This made an especially smart effect. Another case was a  $\frac{1}{4}$  in. line of black edged with carmine, cast upon a field of deep Brewster green. Double lines of gold were much in evidence upon fields of deep blue and green. There is this advantage in favor of gold: no matter upon what field of color it may be employed, gold is always its same royal self, at 100 per cent value the world over. It is a color that looks splendid upon any field and in any surroundings. It can be used to good effect in combination with any other lines, for gold is the one color that harmonizes with any other color regardless of its name or nature. Even the graduated stripe is being used just as it was formerly admired and largely employed upon the horse-drawn vehicle.

The advantage of striping the car, and especially the cheap car, is that it relieves the roughness, if any, of the surface. Many surface imperfections may be passed unnoticed through the medium of the striping. If striping may be indulged in by the rich because, primarily, they are in a position to pay for it, it may with equal advantage be indulged in by the common people. For the cheap car, of all cars, is in real need of the effects which striping afford. Surface imperfections are rendered unnoticeable, or more nearly so, with some striping well executed. Then, too, upon all classes of cars, striping helps to relieve the monotony of color, and helps by contrasts to take the color field out of the common place, and make the entire combination admirable. Deficiencies in the finish, as well as in the surface conditions, are made subordinate through the striping effects. Striping surely appears to be coming into its own.

### The Efficient Varnish Room

In recent years we hear very much less concerning the location of the varnish room, its equipment, etc. Twenty years ago it was esteemed the inner shrine of the shop—almost the sacred place. We suppose that it is none the less highly regarded today, but somehow the almost sacred character of the room has vanished.

The writer recalls a visit he made some few years ago to a very famous paint shop in the vicinity of Times Square, New York, located five or six stories above ground. In one corner of this floor a room had been set aside which was called the varnish room. It appeared commonplace enough; indeed, more so, if anything, than the varnish room he had been used to working in "back home." However, there was a business-like air about the place, and when an inspection of some of the work turned out by the men employed in this paint shop was made, it was at once evident that some one about the place had the ability to "deliver the goods," as the street has it.

The foreman of the establishment offered the explanation that they managed to get on a big bulk of stock—paints, colors and varnishes—and then to top it all off, enough of the finishing varnish was flowed on to in large part drown out all the minor dribs of dust and flocculent matter. Then by keeping the larger atoms of dirt out of the finish the result made the difference between city and country work, so-called.

This varnish room to which we refer was not even located on the corner of the shop where it is commonly deemed necessary that it should be located. If we remember correctly it was stationed at the northwest corner; the window sash were located about shoulder high, and there were plenty of these, so the volume of light, fortunately, was plentiful, which in this case—as it will prove in all cases—gave the working forces a big advantage. The partition setting the varnish room off from the paint shop proper was for its upper half entirely of glass. The varnish room was a plain affair, devoid of any furnishings except those devices absolutely essential. Above all, it was perfectly clean. And in this very ordinary looking apartment some of the finest finished work in New York was being turned out without any fuss or complaint. It proved, as it is always proved, that, after all, it is the man handling the brush that makes the finish. All else is subordinate to this. Make the varnish room the best possible place, give it the necessary equipment, and then man it with a mechanic of superior attainments. This makes the efficient varnish room.

### Essential Details in Repainting

Perhaps striping represents one of these. The car coming to the shop with its body surface badly battered, with but comparatively light painting repairs to be applied, will need something more than mere paint and varnish to make it look presentable. It will require something to relieve the roughness and the lack of finish in the detail effect, and nothing offers more for the effort, and for the money, than some well executed striping effects. These serve to divert the eye from the lack of fine surface detail and make a most acceptable substitute for the purple and fine linen associated with the car surface undamaged and in its original condition.

Surfaces which cannot at the price allowed for the work be made to respond to the best conditions of finished equipment are transformed under striping to most attractive fields of color and of varnish. Broad lines accompanied by distance fine lines, the broad lines being cast in gold or imitation gold, with fine lines done in some contrasting color—and we may say here that almost any nice color will contrast with gold—offer a wonderful relief over surfaces not strictly up to the standard in the matter of smoothness and general conditions.

For light color—say, for example, creams, ivory white, etc.—a broad stripe of aluminum with distance line of blue, or red, shows splendidly, and gives immediate relief to the finish when the surface conditions fall short of being what they should. Then, too, almost all colors are susceptible to some lining work, provided the effects are produced in colors which harmonize with the field color. The fine tones and shades are often developed to their full extent only when suitable striping effects are applied.

It is our humble opinion that all repainted work is materially improved by striping effects carefully selected and skillfully applied. The repainted car should always be

carefully gone over as it is assembled for exit and any surface blemishes, bruises, etc., touched up with a color that matches precisely the color to which it is applied. Little abrasions made in the assembling will need a lick of pigment, or perhaps a bit of varnish will be in order at some point of the work to fetch out the finished appearance. Under no circumstances should the car be allowed to escape from the shop until each fraction of defect is made good. This attention to essential details is appreciated by the average car owner and serves to create new business.

### Government Fixes Paint Shades

The Commercial Economy Board of the Council of National Defense has addressed a communication to the paint and varnish manufacturers stating that the maximum number of shades of paint and grades of varnish to be permitted during the war shall be as follows:

Paints, Enamels, Stains—House paint, 32; flat paint, 16; enamels, 8; floor paint, 8; porch paint, 6; roof and barn paint, 2; shingle stains, 12; carriage paint, 8; oil stains, 8; varnish stains, 8; penetrating or spirit stains, 10; oil colors, 30. (In oil colors black and white are included, but such shades as light, medium, and dark are not counted as additional).

Varnishes—Architectural, interior, and exterior, 10; auto and carriage varnishes and japans, 12; marine, 4; miscellaneous varnishes, 28.

As to can conservation, half-gallon cans and all cans smaller than half-pint throughout the entire line of paints and varnishes are to be eliminated.

Also the following: Pint cans in house paints, flat paints, floor paints, porch paints and enamels; all cans smaller than gallons in barn and roof paint and shingle stain; all cans smaller than pints in all clear varnishes and varnish removers; all two and three-pound cans in the entire line.

Manufacturers are specially urged to economize by utilizing color cards already on hand rather than wasting the supply of these often expensive accessories. Changes may be indicated by the use of a rubber stamp.

Manufacturers who can do so are urged to place orders for cans well in advance, and where possible to substitute other forms of containers.

### Platinum Under Government Control

Platinum has been added to the list of commodities controlled by the government, according to Ordnance Requisition "510." The control will be exercised through the chemical division of the War Industries Board, and a call has been issued for inventories in producers' hands as of March 1. Disposal of all aluminum hereafter is to be for government purposes, except that limited quantities will be released under special permit for essential commercial purposes. The order of priorities will be the same as governs other commodities.

### Government to Erect Assembly Plant

A large plant for the assembling of United States standard army motor trucks will be erected by the government near Baltimore, Md. A tract of 50 acres of land has been purchased for this purpose at St. Helena, about six miles from Baltimore. Work of construction will be begun in the near future.

### Liberty Motor a Packard Product

The Liberty aviation motor is the outcome of three years of Packard work and some half million Packard money, according to a statement made by Emlen S. Hare, president of that concern, at the monthly dinner of the Sphinx Club, held at Waldorf-Astoria, the evening of March 12.

Mr. Hare said that at the time the Liberty motor was taken over by the government an agreement existed between the company and E. A. Dees, then chairman of the Air Craft Production Board, to the effect that the identity of the inventor or producer of the motor should not be revealed.

At the time, it was explained, some government officials feared that if the identity of the Liberty motor was known, other automobile manufacturers might not feel inclined to turn over their plants for its production. There were other reasons, too, why it was thought best to keep the matter a secret. Mr. Hare did not say who the individual inventor of the motor was, or throw light upon the circumstances leading up to its original manufacture by the Packard company.

From what could be learned from Mr. Hare, permission to make the announcement at this time was given by Howard Coffin, chairman of the Council of National Defense, Washington.

In speaking of the progress being made by his company in turning out motors for airplanes, Mr. Hare said:

"Because considerable tooling and special machinery is needed for quantity production of aircraft motors, there is a limit to the number of men we can use at present in that department. However, we have quite as many men employed there as can be profitably used. Further, these men have been drawn from our passenger car department, and just as rapidly as we can profitably use more men on aircraft motors these men are in turn drawn from our passenger car department."

The Packard's executive said that by taking men and machinery from the passenger car department for the company's airplane department it had already been necessary to decrease the output of automobiles. Further decrease in the production of pleasure cars was forecast by Mr. Hare, who added that "it may even be impossible to build any automobiles."

### Incombustible Celluloid

Consul General George H. Scidmore, Yokohama, writing under date of January 9, says: "Correspondence received indicates that a considerable degree of interest has been aroused in the United States in the noncombustible substitute for celluloid which has been invented by a professor in a Japanese university, and for the manufacture of which a company has been organized. The factory buildings are now in course of construction, and it is planned to begin in April of this year, or soon after, the manufacture of waterproof cloth, and composition tiles, buttons, and insulators. As soon as machinery ordered in the United States arrives, the manufacture of imitation leather, linoleum, stained glass, marble, lacquers, and varnishes will be started. Patent rights have been obtained for the process in Japan and have been applied for in Great Britain, France, and the United States. Of the 21 patents applied for in this country, 11 have actually been granted, under date of November 6, 1917, and bear serial numbers 1,245,818

and 1,245,975 to 1,245,984, inclusive. Copies of these patents may be obtained from the United States Patent Office, Washington, D. C., in the usual manner, at a cost of 5 cents each.

"While not perfectly fireproof, this product requires considerable heat to kindle it and burns very slowly.

"The address of the firm engaged in manufacturing this product in Tokyo, and also the name and address of its representatives in the United States, can be obtained at the Bureau of Foreign and Domestic Commerce or its district or co-operative offices by referring to File No. 97,100."

### Carriage Makers' Club Elects Officers

O. B. Banister, Muncie, Ind., in a talk at the annual meeting of the Cincinnati Carriage Makers' Club at the Hotel Gibson, Cincinnati, O., March 7, predicted that if the war continues banquets will be prohibited throughout the United States.

"I wonder if some of the food that we have wasted here tonight wouldn't have helped to feed the boys over in the trenches," he said. Food conservation measures, he added, may soon include the cutting out of all club dinners.

The following new directors were elected: Joseph Walenstein, Clarence J. Rennekamp, Clen Perrine and E. J. Knapp. William F. O'Brien and Knapp were tied in the count. They were notified that they must draw lots to determine the winner, but at this point O'Brien arose and declared that, inasmuch as he had voted for himself, he would withdraw in favor of Knapp. Therefore the latter was officially named the victor.

A. A. Breed, one of the speakers of the War Savings Society, urged upon the carriage men the necessity for their employes forming the thrift habit to enable Uncle Sam to win the war. Among other speakers were P. E. Ebrenz and W. H. Roninger, both of St. Louis, each a former president of the Carriage Builders' National Association, and Theodore Luth, of Cincinnati, also a past president of that organization.

### Dixon Lubrication Chart

The value of lubrication to such an intricate piece of mechanism as an automobile cannot be overestimated. Many inexperienced drivers and owners think that the process of lubricating an automobile consists of applying oil to all open crevices, or holes, but pay not attention to the quality of lubricant, a rather impractical and costly treatment for a machine costing many hundreds of dollars.

Graphite has long been acknowledged as an ideal lubricant for bearing surfaces, and the Dixon graphite lubricants are well known. This company has developed its products to perfection, and to assist motorists they have issued a lubrication chart on this important subject, which will be sent free of charge upon application to the Dixon Graphite Works, Jersey City, N. J.

### Parry Quits Building Buggies

The Parry Mfg. Co., Indianapolis, Ind., whose slogan for many years was "The Largest Carriage Manufacturers of the World," announces that it has made its last buggy and that henceforth it will confine itself to the manufacture of commercial bodies for Fords, Ford trucks and other light trucks.

### **N. A. C. C. to Establish Washington Headquarters**

To further co-ordinate the war needs of the government with the capacities of the automobile plants, the automobile manufacturers in the National Automobile Chamber of Commerce at their session March 7 decided to establish a general headquarters at Washington in charge of Hugh Chalmers, vice-president of the association and chairman of the Chalmers Motor Co.

For some time work of this kind has been cared for by the Automobile Industries Committee, which it was voted to dissolve and to have the automobile manufacturers represented at Washington by a vice-president and staff of the organization. At the headquarters will be engineers to help manufacturers in connection with government work.

A vote of thanks was extended to the members of the Automobile Industries Committee for the work accomplished at Washington.

The members passed a resolution endorsing the work of the newly formed Highways Industries Association and appointed William E. Metzger and Windsor T. White to represent the motor car and truck manufacturers in that organization.

Because of the severe weather and Monday closing orders, the paid attendance at the New York and Chicago shows, for the first time in 17 years showed a falling off from previous records. The reports of the dealers in attendance and business transacted, however, were almost on a par with previous affairs.

There were reports from committees on patents, traffic, good roads, exports and motor trucks, with a meeting of all the motor truck interests held in the afternoon, when plans were suggested for further aid to the government in transportation matters and for the truck industry generally.

---

### **Automobile Manufacturers Propose 30 Per Cent Reduction**

Some time ago representatives of several of the largest automobile manufacturing concerns in the industry were called to Washington, at the request of the War Industries Board and the Fuel Administration, to discuss the situation and determine to what extent further assistance might be rendered and the government needs supplied.

A careful review of the situation, covering a period of several weeks (the automobile manufacturers co-operating with the government to the fullest extent), resulted in the National Automobile Chamber of Commerce, composed of 117 automobile manufacturers, at its meeting March 7, proposing a voluntary 30 per cent reduction in the uncompleted schedules of passenger cars for the present fiscal year.

This arrangement is entirely satisfactory to the War Industries Board, the Fuel Administration and the manufacturers, permitting the latter to adjust their affairs to meet the government program without unnecessary business and financial disturbance.

The importance of the automobile industry and the prominent part it is taking in connection with war work, already supplying Liberty motors and aircraft equipment, trucks, ambulances, munitions, gun carriages, field and road tractors, and tanks, is daily becoming more apparent.

### **W. H. McIntyre Making Ford Auxiliaries**

The many friends of W. H. McIntyre, formerly of Auburn, Ind., and an ex-president of the Carriage Builders' National Association, will be pleased to learn that he is again established in business, operating under the name of the McIntyre Motor Products Co., at 100 to 110 West 55th street (Garfield boulevard), Chicago, in the manufacture of Ford extensions, delivery bodies for Fords and a seven-passenger (extended) Ford.

The ordinary five-passenger Ford is converted into a seven-passenger by an 18 in. extension panel inserted just back of rear door. The additional cross and side braces are mitered, glued and screwed. The outside metal is accurately fitted and the head of the screws are soldered to prevent loosening. 42 in. side channels strengthen and lengthen the frame. The running boards, the top the floor, the shaft are lengthened. Thus plenty of room is provided for a seat to accommodate, comfortably, two additional passengers. This seat faces forward, and can be quickly folded out of the way. Everything is complete, even to the linoleum and metal binding on the running board, the floor carpet, the two additional 18 in. side curtains. The car is sold complete for \$510.

The McIntyre Ford one-ton truck has the McIntyre helper springs, which it is claimed double the carrying capacity of the Ford truck.

The company is offering exclusive agencies and invites correspondence.

---

### **Airplane Mail Service to Start in April**

Daily service by airplane between New York City and Washington is expected to be in operation by April 15 according to plans disclosed by the Postoffice Department. Eight army airplanes will be loaned for the purpose by the War Department, which will incidentally use the service itself for training of army fliers. One trip is to be made each way daily, except Sunday, carrying 300 pounds of first class mail, for which special rates will be charged. Including a stop to deliver mail in Philadelphia, it is estimated that a run will require about three hours.

---

### **Racine Capacity Now 3,500**

A capacity of 3,500 Horseshoe tires and tubes a day has been secured by the Racine Auto Tire Co., Racine, Wis., it having moved into the factory at State and Marquette streets, formerly occupied by the Fisher Wagon Works. The plant consists of a three-story stone building 350 x 220 ft., an administration building 86 x 250, and a large power plant, containing in all 500,000 sq. ft. The old plant, which had a capacity of but 500 tires and tubes a day and was hence unable to supply the demand for the company's product, is to be dismantled.

---

### **U. S. Rubber Buys Alco Factory**

The U. S. Rubber Co. has purchased the plant of the American Locomotive Co., in Providence, R. I., adjoining the Revere Rubber Co. factory, which is devoted to the manufacture of truck tire equipment, including solids and heavy pneumatics. This purchase gives the U. S. Rubber Co. a modern plant of the finest type into which can be carried, among other developments, an expansion of the truck tire equipment manufacture of the big company.



## Standardized Army Trailers

The United States army has now been supplied with designs for standardized war trucks, classes B, A and AA. Following up this work, the Quartermaster Corps has now evolved several designs of standardized trailers, the first of which, a 1½-ton four-wheel type of reversible design, is now being assembled at the plant of the Grant Motor Car Co., Cleveland, O., and the Detroit Trailer Co., Detroit, Mich.

The Quartermaster Corps has worked out these designs with the assistance of engineers of leading trailer concerns, including Troy, Detroit, Sechler, Ohio, Arcadia and others.

This 1½-ton four-wheeled trailer is intended for use behind the Class A war truck. The Signal Corps is to have a standardized two-wheeled, pneumatic-tired trailer

It is understood that General Pershing has requested a two-wheeled trailer with a load capacity of three tons and that this has been laid down on paper, but its manufacture has not been started.

The 1½-ton four-wheeled trailer has a wheelbase of 72 in., a tread of 60 in., and a height of floor above the ground of 42 in. It is mounted on 36 in. wheels allround and 4 in. solid tires. The frame length is 126¾ in., which is sufficient to carry a standard Class "A" Q. M. C. body. Many of the Class "A" truck parts are employed in the job, including the front springs, spring shackles and brackets, yoke on tie or reach rod, and everything on wheel outside of the king bolt. The frame is of 4 in. channel with the springs spaced on 36¾ in. centers in order to prevent excessive side sway. The trailer is made up of 58 different parts other than those of the Class "A" truck design.

All springs are shackled so that they take none of the driving loads, the drive being taken through the frame by means of a two-part drawbar with a spring coupler of composite design. Each pair of wheels is provided with radius rods with ball ends to permit of the necessary universal motion in turning corners and negotiating uneven roads. The trailer can steer from either end and in each case the steering cross rods are behind the axles in order to prevent breakage.

The Signal Corps two-wheeled trailer will be mounted on 35 x 5 pneumatic tires and will have a body about 21 ft. long and 5 ft. wide. The axle will be about 9 in. nearer the rear end than the front. This type of trailer will be able to withstand speeds up to 30 miles per hour.

## General Motors' Excellent Showing

The annual report of the General Motors Corp. for the year ending December 31, shows that there was a substantial increase in business in the last half of the year.

The corporation became the active operating company on August 1, 1917, and its operations cover the last five months of the year. Comparisons, therefore, must be made with the earnings of the General Motors Co., its predecessor, which was dissolved on August 1 last.

In the first seven months of 1917 the General Motors Co., after all deductions for dividends and taxes, had undivided profits of \$12,492,698, whereas in the last five months the General Motors Corp. had undivided profits of \$13,719,983.

The only indebtedness of the corporation and its subsidiary companies consisted of current accounts payable

of \$10,665,717, composed wholly of obligations for merchandise, and \$4,858,326 liabilities accrued but not due for payrolls, etc. The company had on hand net working capital of \$64,554,765 after all deductions. Among its investments is \$1,255,000 in Liberty bonds.

Net sales of General Motors and subsidiary companies from August 1 to December 31, 1917, amounted to \$96,295,740.97. The number of cars and trucks sold in this period was 86,901.

The payrolls for the five months amounted to \$14,248,593. The number of employes of the corporation and subsidiary companies on December 31 was 25,427.

The corporation has acquired a controlling interest in the Samson Sieve-Grip Tractor Co., at Stockton, Cal. The plant is operating to its full capacity. The manufacture of tractors will be extended as rapidly as possible to meet the increasing demand.

## British Carriage Builders' New Officers

At the 36th annual meeting of the Institute of British Carriage Manufacturers held at the Coachmakers' Hall, in London, the following officers were elected: President, R. I. Mussellwhite; vice-presidents, C. Holmes Alex Naughty, J. G. Jacobs; secretary, W. Hamlin Hamshaw; treasurer, Percy Preston; solicitor, E. A. Fuller; auditors, J. W. Connolly, Wm. Stamper. The council is as follows: A. C. Penman, Dumfries; P. Worger, London; A. Barnsley, Wolseley Motors, Ltd., Birmingham; W. F. Adam, Adam, Grimaldi & Co., London; A. W. Auster, Austers, Ltd., Birmingham; W. Lowe, Arrol-Johnston, Ltd., Dumfries.

## Death of E. M. Galle

E. M. Galle, vice-president of The Willoughby Company, Utica, N. Y., died after a short illness, at his residence in that city, early in February. Mr. Galle was at one time draftsman with Brewster & Co., New York. He received the first prize for the best brougham design, offered by the C. B. N. A. at the Chicago convention in 1890. Subsequently he was in the employ of several of the best coach builders in America, including Henry Killam & Co. and Brewster & Co. In 1892 he was appointed instructor in the New York Technical School for Carriage Draftsmen and retained this position until the appointment of Prof. A. F. Johnson, the present instructor. For the last 15 years Mr. Galle had been identified with The Willoughby Company.

## Community Hotel for Buffalo Workmen

Plans are being drawn for a large community hotel to be erected in the vicinity of the plants of the Curtiss Aeroplane & Motor Corp. and the Pierce-Arrow Motor Car Co., which are located near each other at Buffalo, to provide accommodations, with room and bath, for men working on war orders at these two factories.

## Fire in Wagon Plant

The wood-working shop of Joel Turney & Co., Fairfield, Ia., wagon manufacturers, was destroyed by fire March 5, with a loss estimated at \$50,000, partly covered by insurance. It is reported that the company intends to rebuild immediately. The company has been working on war contracts for several months.

# Vehicle Industry News in Brief

## Truck Builders

**Commerce Motor Truck Co.**, Detroit, has received a contract for 1,500 one-ton Commerce trucks for the Ordnance Department.

**LaFrance Motor Truck Co.**, Elmira, N. Y., is having plans drawn for plant additions and alterations, 60 x 160 ft., and 70 x 100 ft., two stories.

**Buffalo (N. Y.) Wagon Works**, 115 Carroll street, manufacturer of wagons, sleighs, etc., is having plans prepared for a two-story addition, 35 x 45 ft.

**Gary (Ind.) Motor Truck Co.** is remodeling its plant for the manufacture of military trucks. The capital stock has been increased from \$50,000 to \$100,000.

**Kelly-Springfield Motor Truck Co.**, Springfield, O., will build a one-story addition, 70 x 140 ft., to its plant. It will be used almost exclusively as a paint shop.

**Duplex Truck Co.**, Lansing, Mich., announces that it will increase the production of motor trucks to 300 per month during this year. H. M. Lee is president.

**Hurlburt Motor Truck Co.**, Third avenue and Harlem River, New York, is planning for expansion of its operations to effect a total production of about 1,800 motor trucks this year.

**Sanford Motor Truck Co.**, Syracuse, N. Y., has increased its capital \$100,000 and the plant is to be increased in floor area 50 per cent., the expansion being necessary to meet numerous orders.

**Troy (O.) Wagon Works Co.** is completing production on an order for 1,250 five-ton trailers for the French government. Each trailer is equipped with separate braking mechanism which acts on each wheel.

**Barger Truck Co.**, which has been formed at Indianapolis, Ind., by Henry W. Barger, Olga Barger and Walter Brevet, with capital of \$50,000, is to build a four-wheel drive truck. The company expects to begin operations at once.

**Reliance Trailer & Truck Co., Inc.**, San Francisco, has been incorporated with a capital of \$25,000 by J. R. Kronetsky, F. E. Carroll, J. M. Litchfield, G. G. Wilkens and S. W. Main, to manufacture automobile trucks, trailers and attachments.

**Kissel Motor Car Co.**, Hartford, Wis., has awarded contracts for two one-story reinforced concrete and brick assembling shop additions, 40 x 200 ft. and 40 x 100 ft. Work will begin at once and it is planned to have the shops ready by April 15 or May 1.

**Blair Motor Truck Co.**, Newark, O., contemplates building an extension to its plant. It is stated that the company will be taken over by a new organization with a capital stock of \$1,500,000, of which J. D. Potter, formerly president of the Kilburn-Jacobs Mfg. Co., Columbus, O., is president.

**Independent Truck Co.** has bought a site in Youngstown, O., on which it will build a plant. Its business is to be removed from Port Huron, Mich. The company has a capital of \$300,000, and its new plant will be capable of turning out about 20 trucks per month. It hopes to have it in operation about May 15.

**Nelson Motor Truck Co.** has been formed to manufacture Jumbo trucks, which were developed by Nelson Bros. Co., of Saginaw, Mich. The first machines produced will be 2½-ton capacity and these will be driven by internal gears. The company intends to increase the number of sizes until a complete series is built.

**Larrabee-Deyo Truck Co.**, Binghamton, N. Y., is to double its production during 1918. The company has increased its capital from \$80,000 to \$300,000. The series of trucks will be completed by the construction of a five-ton size. Last year the company increased its business 210 per cent and the prospect for the coming year is regarded as excellent.

**Guilford Motor Truck Co.**, recently organized with \$250,000 capital, and established at Martinsburg, W. Va., will move to Greensboro, N. C., as soon as a factory can be leased. The company will manufacture a one-ton truck to sell for \$1,075, with a 130 in. wheelbase, worm drive, electric lights and starter. Materials sufficient for the manufacture of 2,000 trucks, with the exception of engines and rear axles, have already been purchased and will be transferred from Martinsburg.

**Winther Motor Truck Co.**, Winthrop Harbor, Ill., has begun the erection of a factory group at Kenosha, Wis., estimated to cost \$125,000, to provide facilities for handling a government contract for military trucks. The company was organized about 18 months ago by M. P. Winther, and being unable to find suitable quarters in Kenosha, availed itself of an offer of the use of an idle shop building at Winthrop Harbor, a few miles southeast of Kenosha. The acceptance of government orders created a need for greatly increased facilities which are expected to be ready about May 15.

**Wisconsin Duplex Automobile Co.**, Clintonville, Wis., has formally transferred its headquarters to Oshkosh, Wis., and for the present will conduct its manufacturing operations in the plant of the former J. L. Clark Carriage Mfg. Co., which is being remodeled and reequipped for the manufacture of one-ton commercial vehicles employing a quadruple drive transmission system. At the first annual meeting held in Oshkosh a new board of directors was elected. William A. Besserdich, formerly of Clintonville, was reelected president and general manager. Other officers are: Vice-president, H. F. Landeck; secretary, B. A. Mosling; treasurer, J. P. Mosling; director, W. G. Maxey. The company has an authorized capital stock of \$500,000. Mr. Besserdich, who designed the chassis which the company will manufacture, was a member of the original firm of Zachow & Besserdich, Clintonville, which has developed into the Four Wheel Drive Automobile Co. of that city.

## Body Builders

**Fisher Body Co.**, Detroit, has let a contract for an airplane factory to be erected on West End avenue and Fort street.

**Hays Mfg. Co.**, Ionia, Mich., maker of automobile bodies, is building an addition to its plant. This is a two-story building, and will be used for finishing work.

**G. A. Freeman** has resigned as vice-president of the J. C. Wilson Co., Detroit, and has joined the airplane body division of the C. R. Wilson Body Co., Bay City, Mich.

**Berwyn Commercial Body Co.**, Philadelphia, has been incorporated with a capital of \$100,000, to manufacture automobile bodies, by Mark C. Mowery, V. T. and L. Cassin.

**Monahan Vehicle Co.**, Providence, R. I., has changed its name, preparing to specialize on bodies for motor trucks. The company is now known as the Providence Body Co.

**C. R. Wilson Body Co.**, Bay City, Mich., has received an order from the government for 1,000 sets of parts for airplanes, the production of which will commence in 30 to 40 days.

**Lobes Body Co.**, Mount Vernon, N. Y., has been incorporated in Delaware, with a capital of \$50,000, to manufacture automobile bodies, etc., by L. C. and J. C. Smith, Mt. Vernon.

**Glassman Auto Corp.**, New York City. To manufacture automobiles, wheeled vehicles and bodies. Capital \$5,000. Incorporators: Arthur Glassman, Francis J. Vallyey, Chas. E. Glassman.

**Mid-West Mfg. Co.**, organized at Hastings, Minn., recently with a capital of \$50,000, has started operations. The company will manufacture airplane parts and commercial bodies.

**Dayton (O.) Body Co.**, whose plant and adjoining property was recently acquired by the government, expects to erect a new factory in Dayton some time this year. It is operating a temporary plant at Springfield, O.

**Detroit Weatherproof Body Co.**, Pontiac, Mich., is enlarging its plant and expects to increase its daily production of sedan tops from 150 to 250. The manufacture of truck cabs and probably other divisions of the body building business will be engaged in by the company.

**Brown-Simpson Motor Co.**, Chattanooga, Tenn, operating a plant for the manufacture of commercial bodies for automobiles and other motor specialties, has been incorporated with a capital of \$10,000. D. S. Simpson, E. A. Simpson and D. K. Brown are the incorporators.

**Utility Hoist & Mfg. Co.**, Milwaukee, has been incorporated with a capital stock of \$25,000, to manufacture small cranes, hoists and specialties for motor truck dump bodies, by W. C. Woodin, A. G. Kritch and A. J. Jansen. Arrangements for equipping a plant are being completed.

**Fisher Body Corporation's** total earnings and income from all sources during the three months ended January 31 last were \$999,626, which, after deducting \$42,611 for interest payments on the company's floating indebtedness, leaves a balance for the quarter of \$957,015. For the nine months from May 1 last to the end of January, total earn-

ings were \$2,809,645, with a surplus for the period amounting to \$2,697,925. From this the amount of excess profits taxes is still to be determined and deducted.

## Car Builders

**Willys Motor Co.** will erect an additional factory building at Elmira, N. Y., 90 x 400 ft., one story, to cost \$80,000.

**White Co.**, Cleveland, has placed contracts for a one-story and basement extension, of brick, steel and concrete, 185 x 400 ft., with a wing, 90 x 185 ft.

**Ford Motor Co.**, Detroit, has produced a new 18-cylinder Liberty motor of over 75 h.p. rating, which it is reported is being manufactured for the government.

**Chandler Motor Car Co.**, Cleveland, will erect a one-story steel and concrete factory, 80 x 400 ft., so constructed that four additional stories can be erected later. For the present the plant will be used to manufacture tractors for the government.

**Maibohm Motors Co.**, Racine, Wis., has issued a report covering its progress for the nine months beginning April 1, 1917, when the company became a Maine corporation. Total assets are placed at \$434,589.01 and the net earnings for the period were \$12,294.17.

**Dodge Bros.**, Detroit, to reduce shipping costs, are installing an industrial railway which will connect most of the ground floor departments of their plants. At present 8,400 ft. of track have been laid and the buildings now under construction will require 5,000 ft. more. The system is of narrow gauge type. The "locomotives" are manufactured in the plant and are driven by a standard Dodge Brothers engine. They comprise 108 flat cars which are run on a regular schedule.

**Studebaker Corp.**, Detroit, expects to be working full speed by the end of March, before which time it will have manufactured 1,000 cars. The three cars which the company has been trying out on the Chicago Speedway, have completed their tests, and have traveled 30,000 miles. The tests were made to secure information for the engineering department. Two of the cars used were six-cylinder touring models, and the third a four-cylinder. The company has let contracts for a brick and steel addition to its factory on Clark and West Jefferson avenues.

## Parts Makers

**Warner Gear Co.**, Muncie, Ind., is preparing plans for a new one-story factory, 135 x 450 ft.

**Jamestown (N. Y.) Wheel & Axle Co.** is taking bids for a factory addition and storage building, 100 x 130 ft., on Tiffany street.

**Imperial Auto Wheel Co.**, Hagerstown, Md., recently organized, is planning the erection of a building to cost about \$10,000. Victor C. West is president.

**Muncie (Ind.) Gear Works** is now actively engaged on government work. An order for 1,000 transmissions for the Class "B" standard army truck is now under way.

**Anderson Co.**, South Bend, Ind., has been incorporated with \$20,000 capital stock to manufacture automobile parts. The directors are John W. Anderson, Adam Keasey and A. G. Graham.

**Hinkley Motors Corp.**, Detroit, is now producing engines for trucks for United States army service and building from 40 to 50 a day. This number will be considerably increased shortly.

**Victor Rubber Co.**, Springfield, O., it is rumored contemplates removing its plant to more commodious quarters in Springfield or to another city. It will be reorganized at an early date and the capital stock increased.

**National Carbon Co.**, Cleveland, will erect additions to its plant at Niagara Falls, N. Y., including a two-story building, 20 x 144 ft., one-story building, 70 x 144 ft., six-story building, 63 x 108 ft., and one-story building, 49 x 70 ft.

**Babcock Automobile Spring Co.**, 192 Milwaukee street, Milwaukee, has awarded contracts for the erection of a new plant and service station costing \$25,000, at Jefferson street and Juneau avenue. It will be 60 x 128 ft., two stories and basement.

**Standard Parts Co.**, Cleveland, is to have a new home. It has leased the fourth, fifth and sixth floors of a six-story building to be erected and to be called the Standard Parts Building. The company will build an addition to its American Ball Bearing plant in Cleveland.

**Homer Laughline Engineers Corp.**, Los Angeles, Cal., announces that the auxiliary transmission for Ford cars and trucks, formerly known as the Langbein, has been purchased by it and will hereafter be known as the Laughlin-Langbein auxiliary for Ford cars and trucks. Homer Laughlin is president of the company; R. H. Boynton, general manager, secretary and purchasing agent; J. A. Enos, vice-president and works manager; C. Russel, treasurer, and Wm. T. Sleddon, sales engineer.

### Immigration in the Future

In my opinion all the warring countries will do everything they can to keep their able-bodied men at home. They will need them for reconstruction purposes. Certainly this will be true of England, Germany and France. Any material immigration from Germany is doubtful. The same is true of France. There has never been much immigration out of France for the reason that the French people are home-owning peasants. In addition, France has been socialized almost as completely as Germany. Something of the same sort has happened in England. In Russia and Austria-Hungary necessity has forced similar activities upon these countries, and they, too, will be in a better position than ever before so far as national political organization is concerned, to take care of the people.

While all this is true, unless the governments forbid it, there will almost certainly be a heavy immigration from Poland, Hungary, Bohemia and the Balkan states. This part of Europe has suffered most from the war. Not less than 10,000,000 people have been driven from their homes. Millions of these people have friends and relatives in the United States, and these millions will look longingly toward a war-free country. And they will be helped to come to America by friends already here.

One thing is certain—there is going to be a big competition for men all over the world. Canada has lost heavily, and Canada will try to draw people from the United States, as well as from England. Mexico will probably be at peace; and while Mexico is not inviting immigration, she is planning to break up the big monopolistic land

holdings in that country and provide free land for settlers. The same is true of Australia.

Instead of a surplus of labor, there may be quite a universal shortage, and those countries that make conditions most attractive for labor are going to secure immigrants and keep their own population. It would not be surprising if hundreds of thousands of able-bodied foreigners leave the United States for Europe. In fact, the steamship companies report from 500,000 to 1,000,000 persons planning to return to Europe after the war. It may be that the action of Europe is preventing immigration, the curiosity and desire of foreigners already in this country to go back home, but most of all the belief on the part of many that they can acquire a piece of land in Europe, will convert America from a nation of immigrants into a nation of emigrants.—Frederic C. Howe, Commissioner of the Port of New York.

### Would Keep Export Trade Alive

Importance of maintaining trade relations in motor vehicles with foreign dealers was considered at a recent meeting of the export committee of the National Automobile Chamber of Commerce. Motor vehicles require little cargo space in proportion to their value and serve to maintain the trade balance and the par value of the gold dollar in such countries as Chile, whose nitrates are required for ammunition, and Argentine, whose beef and wheat are in great demand by America and her allies.

At its meeting the export committee decided to ask the Bureau of Foreign and Domestic Commerce for fuller reports on the motor vehicle trade in foreign countries; to request the War Trade Board to waive export restrictions on automobile parts shipped abroad for repairs and replacements and to clear up the situation regarding licenses on exports of motor vehicles to Canada.

It was also decided to investigate the feasibility of standardizing straight-side tires as equipment on cars for export.

The directors of the chamber have appointed delegates to represent it at the fifth annual foreign trade convention to be held in Cincinnati April 18 to 20 and to make an address.

### Some Ford Figures

The real largeness of the Ford Motor Co. may be conceived by the fact that to produce 900,000 cars it will require: Over 400,000 tons of steel for cars; over 126,000,000 sq. ft. of material for tops; 3,600,000 each of wheels and tires; 4,500,000 lamps; 15,884,414 ft. of vanadium steel shafting and axles; 4,938,000 sq. ft. of glass for windshields; 109,484,404 ft. of copper tubing for radiators; 12,900,000 lbs. of steel for magnetos; 7,836,593 sq. ft. of galvanized metal for gas tanks; 69,959,951 sq. ft. of sheet metal for fenders and guards; 27,940,382 ft. of tubular radius rods; 156,546 freight cars full loaded, besides about 79,534,404 lbs. of materials in less than car lots, to bring in the materials and carry Ford cars to dealers throughout the country.

The government has fixed a maximum base price for virgin aluminum ingots at 98-99 per cent pure, of 32c at the various producing plants of the Aluminum Company of America, the only producers of virgin aluminum in America today. This price is to be subject to revision on June 1, 1918. The quotation refers to 50-ton lots.

**Ratio of Automobile Accidents Decreasing**

As the result of a careful study of the police department records of automobile accidents in New York City, the department of health finds that the number of deaths caused by automobiles in the city has decreased from 8.32 per 1,000 cars registered in the state in 1902 to only 1.25 per 1,000 in 1916.

"If the ratio of deaths from automobile accidents to automobiles operated that prevailed in 1908 had prevailed in 1916, over 1,600 persons would have been killed," says Dr. S. W. Winne, assistant registrar of the department of health, "and if we assume that the ratio of deaths to accidents remains fairly constant year after year, about 30,000 persons would have been injured instead of 7,500.

"The death rate of automobile accidents is not the result of increased carelessness but rather the result of the increased number of automobiles operated in the city.

"While there still remains an important element of carelessness and even recklessness upon the part of operators, the most important factor is the congestion of the city streets by pedestrians and vehicular traffic. It would therefore seem that our greatest efforts must be directed toward the correction and relief of this congestion"

**Ford Making Tanklets**

In addition to little naval vessels, the Ford plant is said to be busy on the first of a large flock of tanklets of the caterpillar type, bearing about the same relation to the big tanks that the Ford truck bears to a ten-tonner. The crew, it is said, will consist of the driver and a machine gunner.

**Death of Louis Buob, Sr.**

Louis Buob, Sr., 57, founder and president of the Buob & Scheu Buggy Co., carriage and auto top makers, Cincinnati, died at his home, 4303 Virginia avenue, Northside, February 26. Besides his wife he is survived by four children.

**Population of the United States**

The population of Continental United States on January 1 is estimated by the Treasury Department at 105,006,000.

**WANTS**

Help and situation wanted advertisements, 1 cent a word; all other advertisements in this department, 5 cents a word; initials and figures count as words. Minimum price, 30 cents for each advertisement.

**Wanted**—Copies of The Hub of May and July, 1916. Must be in good condition. Address Trade News Publishing Co., corner Elm and Duane streets, N. Y. City.

**PATENTS**

**Patents**—H. W. T. Jenner, patent attorney and mechanical expert, 606 F St., Washington, D. C. Established 1883. I make a free examination and report if a patent can be had and exactly what it will cost. Send for circular.

**HELP WANTED**

**Wanted**—Working foreman in woodworking department of custom commercial body factory. Must have ability to do fine work and manage workmen; also some designing ability. Apply Box 888, Ogden, Utah.

**Index To Advertisers**

Barrell Co., Wm. L.....	37
Bradley, C. C., & Son.....	41
Bridgeport Coach Lace Co.....	3
Century-Plainfield Tire Co.....	6
Century Steel Co. of America, The.....	6
Columbus Bolt Works.....	Back cover
Cowles, C., & Co.....	40
Crane & MacMahon, Inc.....	Back cover
Decker, J. C.....	40
Dixon, Joseph, Crucible Co.....	7
Dowler, Chas. L.....	40
Doxey, N. D.....	43
DuPont Fabrikoid Co.....	37
Eccles, Richard, Co.....	39
G & O Mfg Co.....	43
Gray, Peter, & Sons, Inc.....	41
Hartford Auto Parts Co.....	3
Hotel Rochester.....	41
Johnston, R. F., Paint Co.....	40
Judd & Leland Mfg. Co.....	4
Keratol Co., The.....	37
Laidlaw Co., The.....	43
Liberty Loan Committee.....	36
Mulholland Co., The.....	40
National War Savings Committee.....	38
Norton Grinding Co.....	5
O'Bannon Corporation.....	Back cover
Parrott Varnish Co., The.....	42
Paulson, Thomas, & Son, Inc.....	42
Pierce Co., F. O.....	42
Porter, H. K.....	43
Pressed Steel Co.....	37
Quickwork Co., The.....	43
Rome-Turney Radiator Co.....	39
Russell, Birdsall & Ward Bolt & Nut Co.....	41
Sheldon Axle & Spring Co.....	Front cover and 8
Standard Oil Cloth Co., Inc.....	2
Wayne Wheel Co.....	42
West Tire Setter Co.....	42
White-Quehl Mfg. Co.....	40
Wilcox Mfg. Co., D.....	42
Willey Co., C. A.....	39
Wing, Chas., Co.....	40



# America Must--- and America Can

**T**HERE is no longer any doubt that the American army and navy must win this war.

There is no doubt that America can win the war if a united country strikes with all the might of its wonderful resources and magnificent manhood.

There is no doubt that weakness, disunion, indecision and delay will spell disaster.

There is no doubt that such a disaster would mean the unnecessary loss of hundreds of thousands of American lives, the invasion of our country by a brutal and remorseless enemy, and misery, devastation and economic slavery.

**The Third Liberty Loan will hasten the day of VICTORY and still further insure us against a fate which every true American would give his life to avert. Remember this when you buy your bonds—and buy all you possibly can.**

LIBERTY LOAN COMMITTEE  
Second Federal Reserve District  
120 BROADWAY, NEW YORK CITY



# Keratol LEATHER SKINS

For the car where leather has always been used



## PRICE

*Within Reason*

## QUALITY

*Maintained*

### W<sup>m</sup> L. BARRELL Co.

8 THOMAS ST.  
NEW YORK

DU PONT AMERICAN INDUSTRIES



REG. U. S. PAT. OFF.

### Washable Ambulance Upholstery

Du Pont Fabrikoid is the safest material that can be used in ambulance work.

It is absolutely impervious and sanitary, cannot absorb dirt or germs and spread infection. The surface of Fabrikoid is like glass. It can be washed with water or antiseptic solutions and kept perfectly clean under the most trying conditions. Over in France it is saving lives every day.

Write for samples and prices

### DU PONT FABRIKOID CO.

WILMINGTON, DEL.

Canadian Factory and Office, New Toronto, Ont.



One of a Series of Ambulances Upholstered in Craftsman Quality Fabrikoid

# steel stampings

*especially for*

## COMMERCIAL TRUCKS

The Pressed Steel Company  
Wilkes-Barre, Pa.

Please mention "The Hub" when you write.

# The 1st of May Thrift Stamp Day in The U. S. A.

The Active Co-operation of Every Reader of  
**THE HUB**

Is Urgently Requested to Make It a Success

May 1st, 1918, will be observed throughout the United States as Thrift Stamp Day! On that day retail stores everywhere in every line of business will ask customers to take **part of their change in Thrift Stamps!** It will be patriotic for every man, woman and child to accept at least one Thrift Stamp as change on every purchase made that day—and to make as many purchases as possible on May 1st.

Here is a big, practical way of getting millions of Thrift Stamps into the hands of the people of the United States, and of insuring the success of the Government's War Savings Stamps campaign. Thrift Stamp Day will **help everyone.** It will prove a tremendous boost to business. On May 1st, 1918, the nation should do the biggest total retail business of any single day in our history! The beneficial habit of Thrift will be sown broadcast among the citizens of the

U. S. A.! Most important of all, Uncle Sam will be furnished with the sinews of War and Victory!

American business must go "over the top" **at once** in a quick drive to make Thrift Stamp Day an overwhelming success. You wholesalers, you jobbers, you salesmen, must **talk** Thrift Stamp Day among your trade, arouse the **enthusiasm** of the retailers, the storekeepers, the clerks behind the counters. Uncle Sam **needs your help.** A practical **plan** has been prepared showing how each one of you can "do your bit" to make Thrift Stamp Day a red letter day in American business annals. Write for this plan **today without fail.** Remember, in helping Uncle Sam you are helping business and helping yourselves. Address Mr. W. Ward Smith, National War Savings Committee, 51 Chambers St., New York City.

**NATIONAL WAR SAVINGS COMMITTEE**

**51 CHAMBERS STREET, NEW YORK CITY**

# RADIATOR INSURANCE

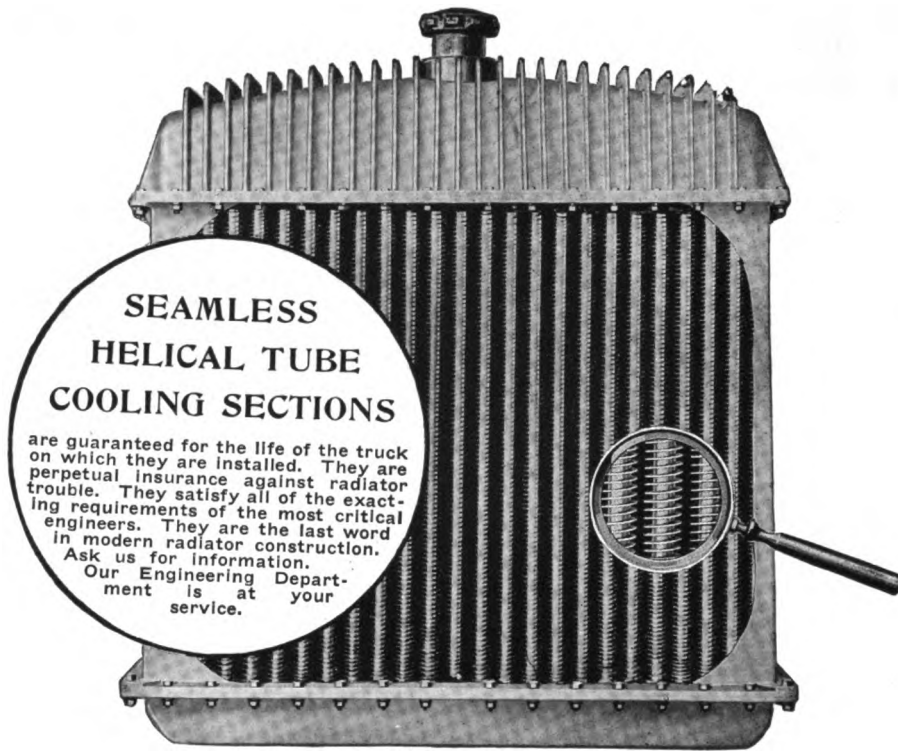

**ROME-TURNEY RADIATOR CO., Sole Manufacturers, ROME, N. Y.**

## WILLEY'S COLORS

The Recognized Standard



**C. A. WILLEY CO.**  
COLOR GRINDERS

and Manufacturers of Specialties in

**CARRIAGE, AUTOMOBILE and CAR**

**PAINTS**

**COLORS, VARNISHES, ETC.**

**HUNTER'S POINT, NEW YORK CITY**

## Automobile, Carriage, Wagon and Special FORGINGS

of Guaranteed Quality

When you are in the market, send us your blue-prints for quotations.

Ask for catalog showing part of our large line of Automobile and Special Forgings, also catalog listing our full line of Carriage and Wagon Hardware.

**Richard Eccles Co.**  
AUBURN, NEW YORK

ESTABLISHED IN 1880

Please mention *The Hub* when you write

# BUSY BUYERS BRIEFS

## JOHNSTON'S KRAKNO

Color Card Free  
**\$3.50 per gallon**  
The R. F. Johnston Paint Co.  
Cincinnati, Ohio

## THE CHARLES WING CO.

Established 1848  
Manufacturers and Wholesale Dealers in  
**AUTOMOBILE AND CARRIAGE  
HARDWARE AND TRIMMINGS**  
AMESBURY, MASS., U. S. A.

## Why Not Have the Best?

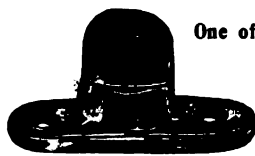

One of a Large Variety

G. Cowles & Co.  
NEW HAVEN,  
CONN.

## J. C. DECKER

MONTGOMERY, PA.  
Manufacturer of

## Carriage, Skate and Pad Straps

Side Loops, Bridle Fronts, Tail Ties, etc.

## CHARLES L. DOWLER

CARRIAGE AND WAGON HARDWARE  
108 North Third St., Philadelphia, Pa.

## CUSHION MANUFACTURER

Pure Stearic Acid Candles. Wheel Stock. Snow  
Flake Axle Grease.

## MULHOLLAND BUGGY SPRING

Reduces weight of springs one-half.  
Made in one size only but will fit bodies  
of all widths.  
Write for further particulars and prices.  
THE MULHOLLAND CO. DUNKIRK, N. Y.

## White's Brazing Sleeves

For applying Rubber Tires  
Send for Samples.

## WHITE-QUEHL MFG. CO.

431 E. Pearl St.  
CINCINNATI, OHIO

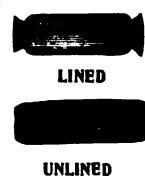

# CLASSIFIED INDEX

For Addresses See Alphabetical Index  
and Advertising Pages

### ANTI-FRICTION METALS

Thomas Paulson & Son, Inc.,  
Brooklyn, N. Y.

### AUTOMOBILES

American Motors Corp., Plain-  
field, N. J.

### AUTO FABRICS

Barrell, Wm. L., Co., New York  
Keratol Co., The, Newark, N. J.  
Laidlaw Co., Inc., The, New  
York.  
O'Bannon Corp., New York City  
Standard Oil Cloth Co., New  
York City.

### AUTO PARTS

Hartford Auto Parts Co., Hart-  
ford, Conn.

### AXLES (Including Ball and Roller Bearing)

Sheldon Axle & Spring Co.,  
Wilkes-Barre, Pa.

### BOLTS AND NUTS

Columbus (O.) Bolt Works Co.  
Russell, Burdsall & Ward Bolt  
& Nut Co., Port Chester, N.Y.

### BOLT CLIPPERS

Porter, H. K., Everett, Mass.

### BRAZING SLEEVES

White-Quehl Mfg. Co Cincinnati,  
O.

### DIES

Bliss Co., E. W., Brooklyn, N.Y.  
(Sheet Metal Working).

### FORGINGS

Eccles, Richard, Auburn, N. Y.  
(Carriage, Drop).  
Williams, J. H., & Co. Brook-  
lyn, N.Y. (Automobile, Drop)

### FIFTH WHEELS

Wilcox Mfg. Co., D., Mechanics-  
burg, Pa.

### HARDWARE (Carriage, Wagon and Automobile)

Columbus (O.) Bolt Works Co.  
Dowler, Chas. L., Philadelphia.  
Eccles Co., Richard, Auburn,  
N. Y.  
Wilcox Mfg. Co., D., Mechan-  
icsburg, Pa.  
Wing Co., Chas., Amesbury,  
Mass.  
Cowles, C., & Co., New Haven,  
Conn.

### LEATHER SUBSTITUTES

Barrell Co., Wm. L., New York.  
DuPont Fabrikoid Co., Wil-  
mington, Del.  
Keratol Co., The, Newark, N. J.  
O'Bannon Corp., New York City  
Standard Oil Cloth Co., New  
York.

### LUBRICANTS

Dixon, Jos., Crucible Co., Jer-  
sey City, N. J.

### MACHINERY AND TOOLS

Bliss Co., E. W., Brooklyn, N.Y.  
Norton Grinding Co., Worces-  
ter, Mass.  
Pettingell Machine Co., Ames-  
bury, Mass.  
Simmons Machine Co., Inc.,  
Albany, N. Y.; Singer Bldg.,  
New York City.  
Smith, H. Collier, Detroit, Mich.  
West Tire Setter Co., Roches-  
ter, N. Y.  
Williams, J. H., & Co., Brook-  
lyn, N. Y.  
White-Quehl Mfg. Co., Cincin-  
nati, O.  
Yoder Co., The, Cleveland, O.

### MACHINERY (Metal Working)

Bliss Co., E. W., Brooklyn, N.Y.  
Pettingell Machine Co., Ames-  
bury, Mass.  
Quickwork Company, Detroit,  
Mich.  
Yoder Co., The, Cleveland, O.

### METAL STAMPINGS AND NOVELTIES

Gray, Peter, & Sons, Inc., Cam-  
bridge, Mass.  
Pressed Steel Co. of New York,  
New York City.

### PATENTS

Jenney, H. W. T., Washington,  
D. C.

### PAINTS AND COLORS

Johnston Paint Co., R. F., Cin-  
cinnati, O.  
Pierce Co., F. O., New York.  
Willey Co., C. A., Hunter's  
Point, N. Y.

### PRESSES

Bliss Co., E. W., Brooklyn, N.Y.  
(Drop, Power).

### RADIATORS

G. & O. Mfg. Co., New Haven,  
Conn.  
Rome-Turney Co., Rome, N. Y.

### SCHOOL FOR DRAUGHTS- MEN

Mechanics' Institute, New York

### SHAFT COUPLINGS

Bradley & Son, C. C., Syracuse,  
N. Y.  
Eccles Co., Richard, Auburn,  
N. Y.

### SPARK COILS

Pittsfield Spark Coil Co., Pitts-  
field, Mass.

### SPRINGS

Mulholland Co., Dunkirk, N. Y.  
Sheldon Axle & Spring Co.,  
Wilkes-Barre, Pa.

### STEEL

Century Steel Co. of America,  
Poughkeepsie, N. Y.; Sales  
office, 120 Broadway, N. Y.

### TIRES

Century-Plainfield Tire Co.,  
Plainfield, N. J.  
TIRE PUMPS  
Judd & Leland Mfg. Co., Clifton  
Springs, N. Y.

### TOOLS

Williams, J. H., & Co. Brook-  
lyn, N. Y.

### TRIMMING MATERIAL

Bridgeport (Conn.) Coach Lace  
Co.  
Decker, J. C., Montgomery, Pa.  
Wing Co., Chas., Amesbury,  
Mass.

### UNIVERSAL JOINTS

Hartford (Conn.) Auto Parts  
Co.

### VARNISH AND JAPAN

Parrott Varnish Co., Bridgeport,  
Conn.  
Pierce Co., F. O., New York.  
Willey Co., C. A., Hunter's  
Point, N. Y.

### VARNISH RENOVATOR

Poughkeepsie (N. Y.) Utilities  
Corp.

### WELDING COMPOUND

N. D. Doxey, Elmira, N. Y.

### WHEELS



Crane & MacMahon, Inc., New  
York City.  
Hoopes Bros. & Darlington,  
Inc., West Chester, Pa.  
Wayne Wheel Co., Newark, N.J.

### WOOD BENDINGS, WHEEL STOCK, ETC.

Crane & MacMahon, Inc., New  
York City.

Please mention "The Hub" when you write



 <p>The Only One-piece Moulded Leather Packing</p>	<h2 style="text-align: center;">The Bradley Carriage Coupler</h2> <p style="text-align: center;"><i>All-Steel   Noiseless   Quick-Shifting   Ball-Bearing</i></p> <p style="text-align: center;">(MADE IN FIVE SIZES FOR AXLES 1/4 INCH TO 2 1/4 INCH)</p> <p style="text-align: center;">The <i>only</i> carriage coupler that is furnished with a <b>ONE-PIECE MOULDED LEATHER PACKING</b></p> <p style="text-align: center;"><b>C. C. BRADLEY &amp; SON, Syracuse, N. Y.</b></p>	 <p style="text-align: center;">The Bradley Carriage Coupler</p>
---	---	---

## HOTEL ROCHESTER

Rochester, N. Y.

"A Tone All Its Own"

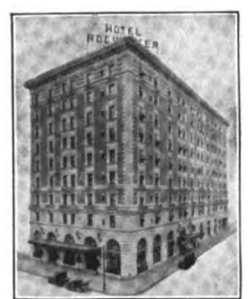

300 Rooms with Bath

One of the Finest Equipped  
Hotels in the World  
EUROPEAN PLAN \$1.50 UP  
Club Features in Restaurant

MILTON ROBLEE, Manager

## Sheet Metal Specialties



WE are in a position to furnish *Sheet Metal Stampings* in all kinds of metal at the rate of several hundred thousand pieces per day.

Special attention given to rush orders.  
Send us your inquiry with specifications.

**Peter Gray & Sons, Inc.**  
Cambridge, Mass.

Subscribe Now for	<b>THE HUB</b>	<b>\$2.00 Per Year</b>
----------------------	----------------	----------------------------

## RUSSELL, BURDSALL & WARD BOLT & NUT CO.

Established 1845 PORT CHESTER, N. Y.

**MAKERS OF THE CELEBRATED EMPIRE BOLTS AND NUTS**

Western Office: Continental & Commercial Bank Bldg., Chicago, Ill. Branch Works: Rock Falls, Ill.

Please mention "The Hub" when you write

The machinery of the country is running at top speed to supply war needs. Machines are supplementing man power to make up for labor



shortage. The wheels **MUST** be kept turning—automobiles, gas, oil and steam engines, railway trucks, generators and everything that runs in bearings.

## “HECLA” ANTI-FRICTION BRONZE

will keep them moving, smoothly and efficiently. This alloy is the result of 32 years' experience and research. “HECLA” WILL NOT CUT the journal or pin under the severest service conditions. Will not pound out or break, MACHINES CHEAPLY and has NO SUPERIOR regardless of price. Let us send the little “Hecla” booklet. We also make Castings—finished or rough, in Brass, Bronze, Aluminum, Hydraulic Metals, Copper, Acid Metal.

**BRASS FOUNDERS ENGINEERS** **THOMAS PAULSON & SON, Inc.** 97 SECOND AVENUE BROOKLYN, N. Y.

## PARROTT VARNISHES



.. Unequaled for ..

**Automobile  
and  
Carriage  
Finishing**

**The Parrott Varnish Co.**  
Bridgeport, Conn.

## AUTOMOBILE WHEELS

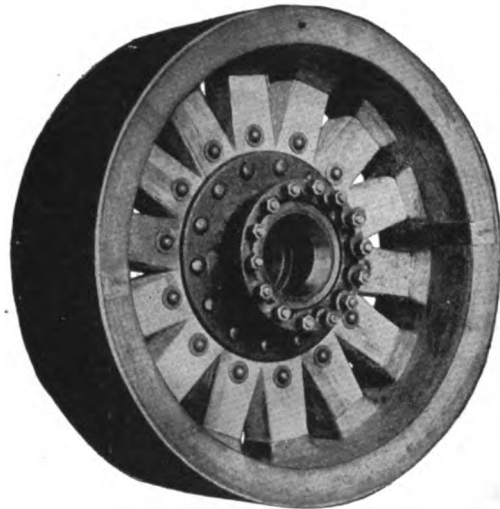

Have you seen our *new* construction?  
Better write us for particulars.

**Wayne Wheel Co.**  
Newark, Wayne Co., New York

## CUT DOWN THE EXPENSE

The West Hydraulic Tire Setter

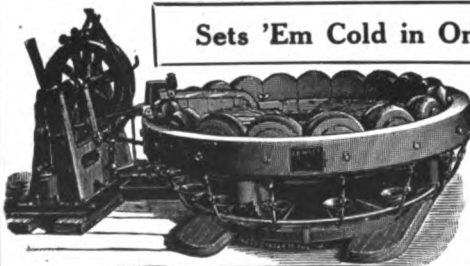

Sets 'Em Cold in One Minute

No burned streaks.  
One wheel only to measure in a lot.  
No charred rims.  
Saves Re-sandpapering.  
**Pays for Itself.  
Your Profit.**

**The West Tire Setter Co.,** ROCHESTER, N. Y.

## WILCOX

FINE  
FINISHED  
FORGED

**CARRIAGE HARDWARE  
AND GEAR IRONS**

Write for Prices and Catalog

**The D. Wilcox Mfg. Co.**  
MECHANICSBURG, PA.

Please mention The Hub when you write

The  
**Laidlaw Company**

Inc.

New York City

.....

**Automobile  
Fabrics**

.....

**A Fabric for  
Every Purpose**

**For Closed, Open or  
Convertible Bodies**



**ANCHOR  
WELDING  
COMPOUND**

MANUFACTURED BY

**N. D. DOXEY, ELMIRA, N. Y.**

ANCHOR WELDING COMPOUND will weld hardest steel. Will not peel apart at the weld, thus losing the heat, nor burn up when flowing on the lap. Will weld without the use of hammer. Place two flat surfaces together in the fire, smelting the Compound liberally on the parts and press together firmly with tongs, and weld will be complete without a stroke of the hammer. It will not require any iron fillings to be added in welding as in some other compounds. It does the work itself. A weld made with ANCHOR COMPOUND leaves the welded parts of equal strength with solid parts of the metal. Cannot be damaged by dampness nor by heat.

Your Welding Compound gives entire satisfaction. In welding steel of high carbon, it fluxes quick and the steel appears like iron, and can be worked at a white heat. I have tried all other compounds in the market and can pronounce yours the best. It flows where you want it to flow.

C. H. KILMER, Elmira, N. Y.

We take pleasure in stating that we have been using your Welding Compound for several years and find it a most excellent article, and can recommend it highly. Yours truly,  
THE LAFRANCE FIRE ENGINE CO.,  
W. Falck, Gen. Manager, Elmira, N. Y.

Is used by U. S. Navy and C. & N. W. Ry. Co. and many others.

IN USING do not throw the Compound from the surface to be welded, but cup the scarf, and in light work turn the piece, when ready for welding, so that the Compound will flow evenly over the surface to be welded, which it will readily do, flowing like oil. In heavier work, add compound to surface to be welded, as heat nears welding point, so that surface to be welded is covered with fused compound.

**PORTER'S BOLT CLIPPERS**

"Easy" "New Easy" Allen-Randall



To Cut 5-16, 3-8, 1-2, 5-8, 3-4 Inch.

**H. K. PORTER, EVERETT, MASS.**

**"Quickwork"**

Sheet Metal  
Working Machinery

For Automobile and Carriage Bodies, Fenders, Hoods, etc.

**THE QUICKWORK CO.**

H. COLLIER SMITH, Pres. and Gen. Mgr. ST. MARYS, O.

**Results Always Follow  
Advertising in**

**THE HUB**

**It Pays  
Others  
It Should  
Pay You**



ENGINE COOLING

**RADIATORS**

FOR PLEASURE CAR AND HEAVY DUTY SERVICE

**G & O MFG. CO. - New Haven, Conn.**

*The Hub*

**AUTOTRUCK**

**Hickory Nut and**

BEST QUALITY STOCK  
TOUGH AND HEAVY

BONE DRY

MANUFACTURED BY  
CAPABLE MECHANICS  
AND MOST  
IMPROVED MACHINERY

WHEELS WHICH ADD TO  
THE LIFE OF YOUR TRUCK

ST. MARYS, OHIO

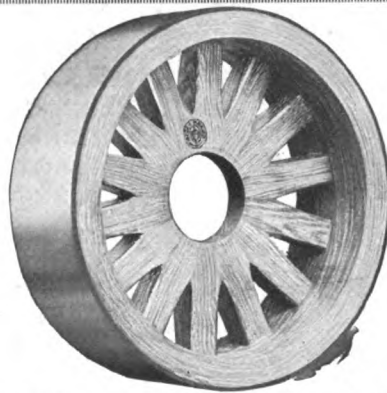

**WHEELS**

**Acorn Brands**

HORSE-DRAWN  
VEHICLE WHEELS  
ALL STYLES

TRAILER WHEELS:  
SARVEN AND  
ARTILLERY TYPES

HIGH STANDARD OF  
QUALITY AND  
WORKMANSHIP  
MAINTAINED

8 BRIDGE ST., N. Y. CITY

**CRANE & MacMAHON, Inc.**

**O'BANNON**

**THE IDEAL TOP MATERIAL**

**COATED FABRICS**

*Variety of Qualities*

WRITE FOR SAMPLES

**O'BANNON CORPORATION**  
200 FIFTH AVE. NEW YORK

**THE SUPERIOR LEATHER SUBSTITUTE**

**O'BANNON INTERNATIONAL**

**O'BANNON LEATHER**

**Skewed Shaft Couplings**

**Regular or Oval Patterns  
For High Arched Axles**

Furnished in rights and lefts for any height of arch.  
Oval Axle Clips  $\frac{5}{8}$  or  $\frac{3}{4}$  width to match Oval  
Couplings. Bolts, Clips, Couplings, Carriage  
Hardware and Special Forgings

Catalogue "H" and Prices on Application

**COLUMBUS BOLT WORKS COMPANY**  
COLUMBUS, OHIO

Please mention "The Hub" when you write







UNIVERSITY OF MICHIGAN



3 9015 08011 0524



